

PM : 紀明進 Sunyu Jih  
 EE Laerer : 許高銘 Jim Hsu  
 ME Leader : 林哲敏 Mill Lin

PCI ROUTING TABLE	IDSEL	INTERUPT	DEVICE
REQ0# / GNT0#	AD18	INTA#	M11
REQ1# / GNT1#	AD20	INTD#	BROADCOM LAN
REQ2# / GNT2#	AD23	INTB# , INTC#	MINI-PCI
REQ3# / GNT3#	AD22	INTE# , INTF# , INTG#	TI 7411

**PROJECT : ZL1**  
**Quanta Computer Inc.**

Size	Document Number	Rev
	<b>BLOCK DIAGRAM</b>	A1A
Date: Friday, June 04, 2004	Sheet 1 of 35	

# Banias

1 OF 3

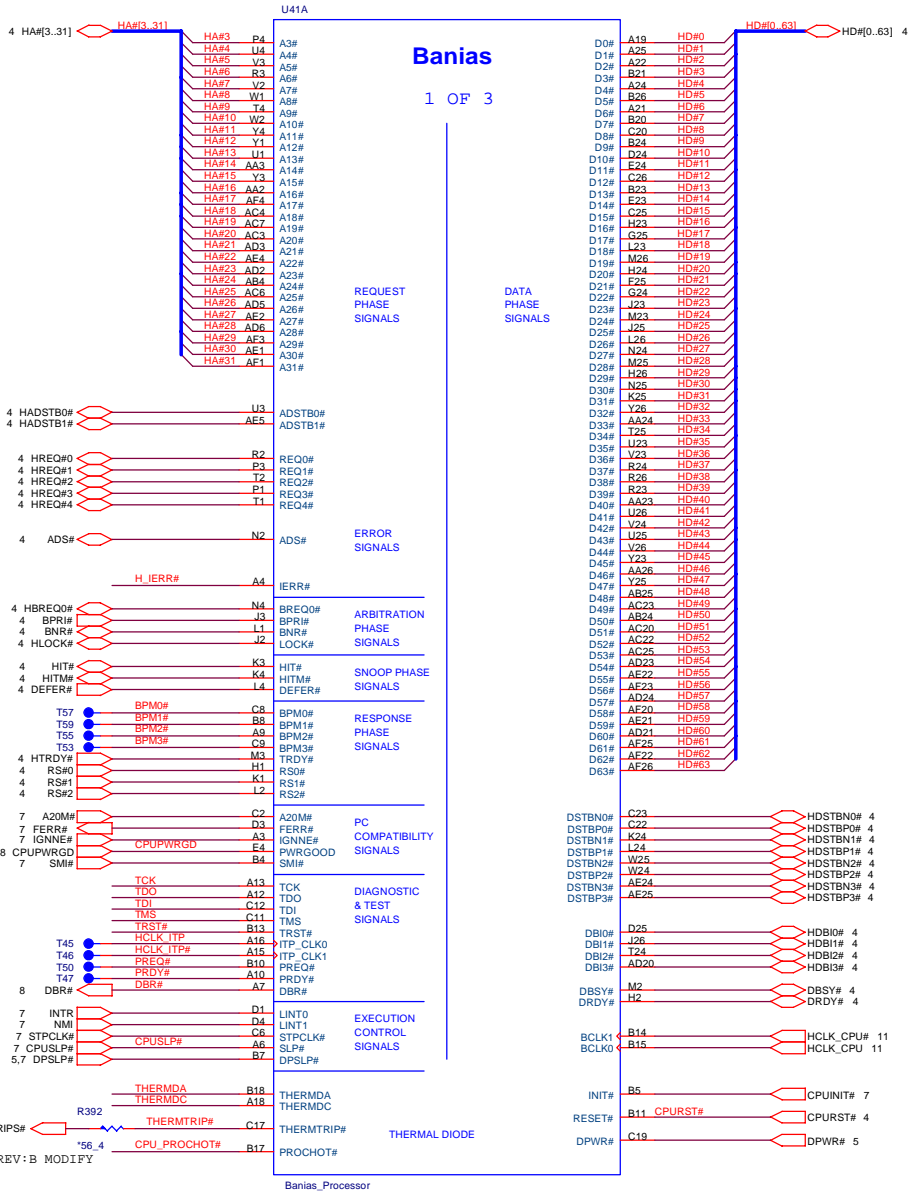

# H/W MONITOR

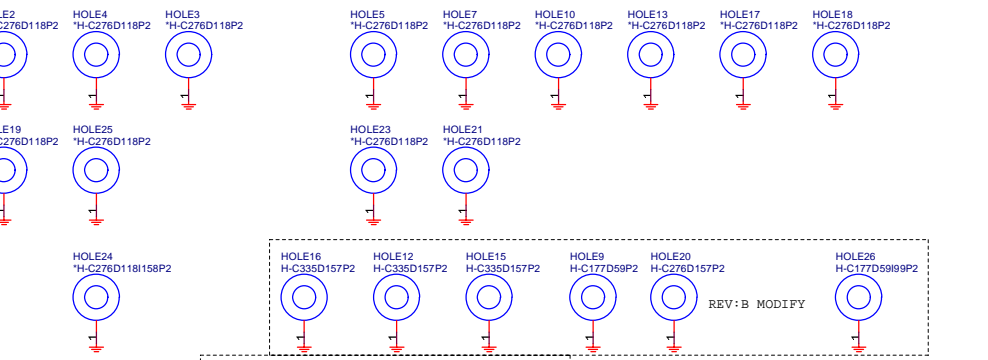
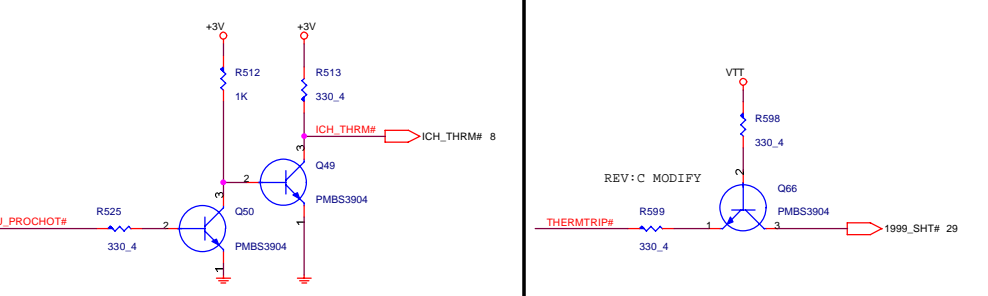
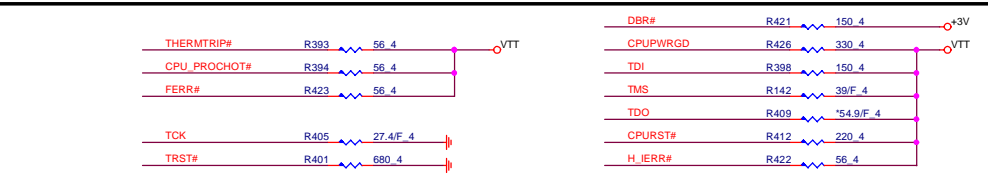
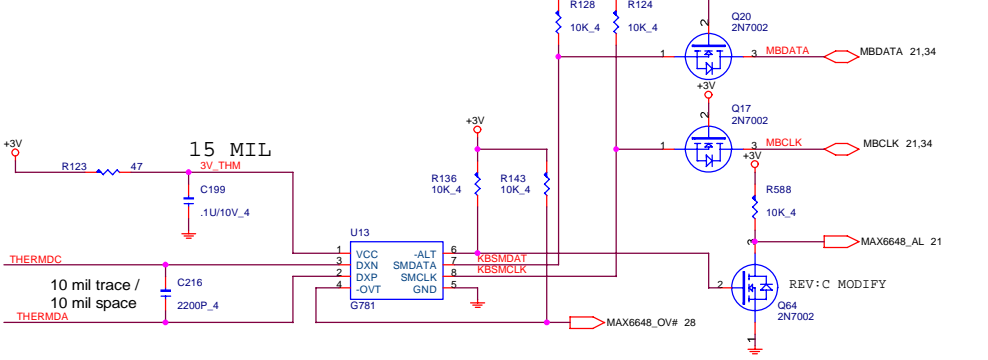

**PROJECT : ZL1**  
**Quanta Computer Inc.**

Size Document Number Rev  
**CPU (HOST BUS)-1** C3A

Date: Friday, June 04, 2004 Sheet 2 of 35

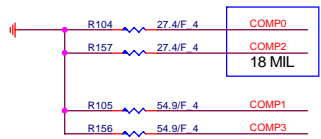

COMP0 - 4  
max length  
500 MIL

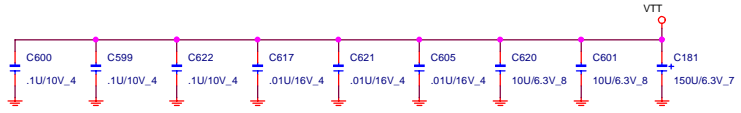
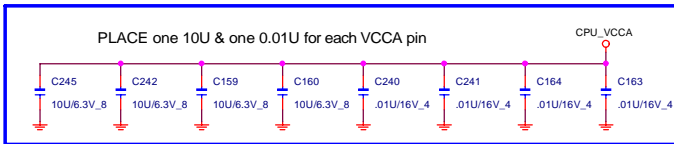
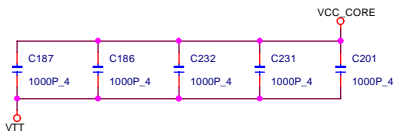

10U/6.3V/X5R(CC0805) \*30

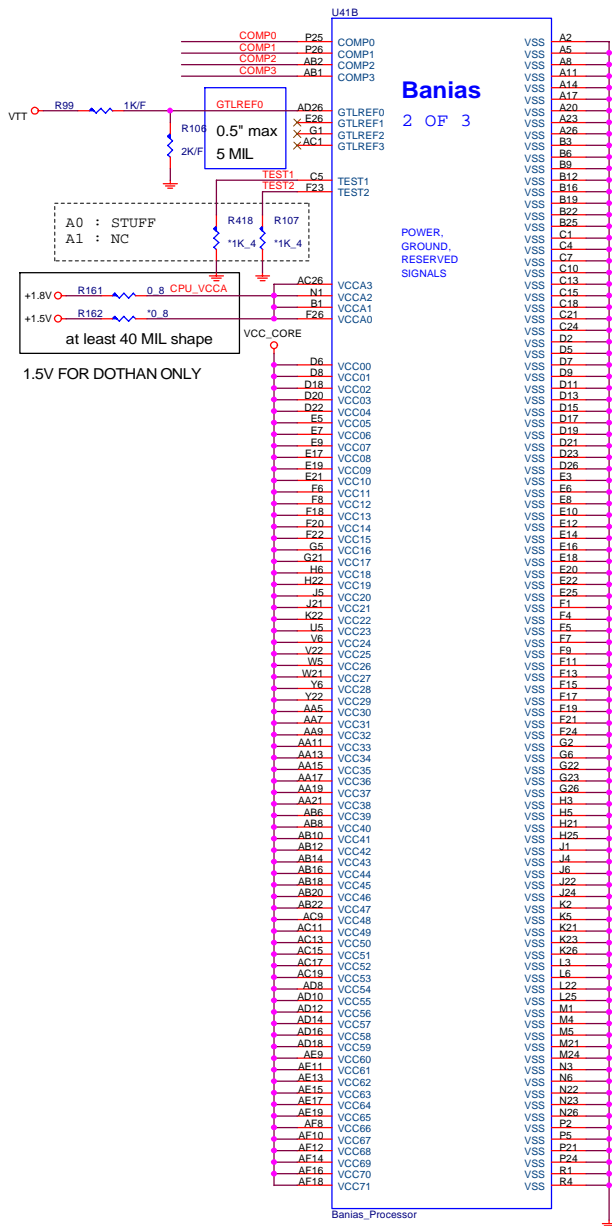
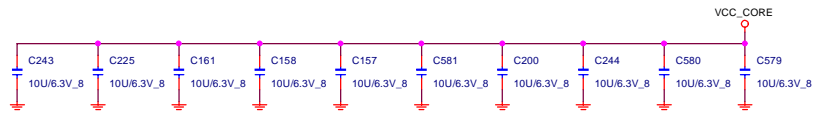
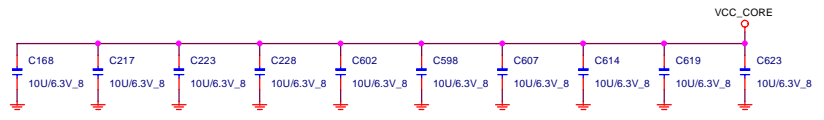
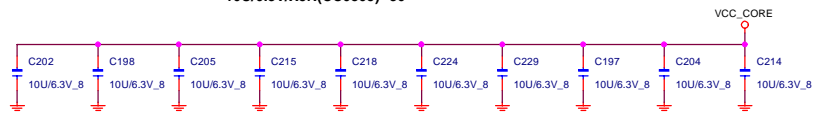

Banias  
2 OF 3

POWER,  
GROUND,  
RESERVED  
SIGNALS

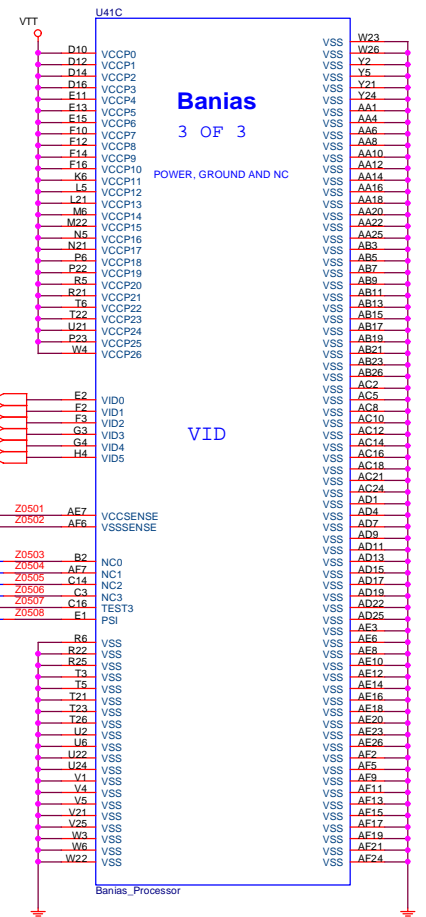

Banias  
3 OF 3

POWER, GROUND AND NC

VID

**PROJECT : ZL1**  
**Quanta Computer Inc.**

Size	Document Number	Rev
	<b>CPU (POWER)-2</b>	A1A
Date:	Friday, June 04, 2004	Sheet 3 of 35

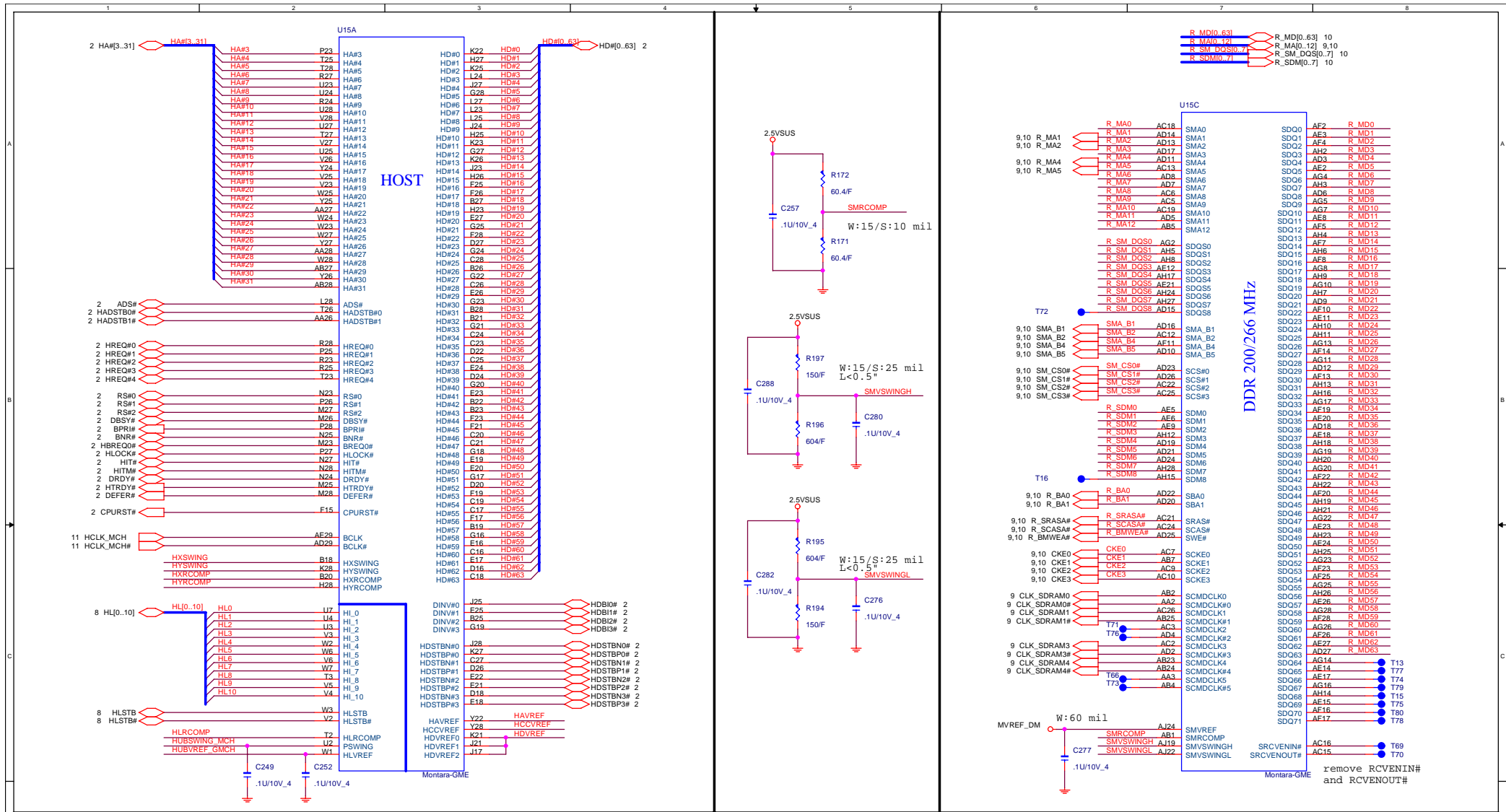

**PROJECT : ZL1**  
**Quanta Computer Inc.**

Size	Document Number	Rev
	<b>GMCH_A (HOST &amp; DDR)</b>	A1A
Date:	Friday, June 04, 2004	Sheet 4 of 35

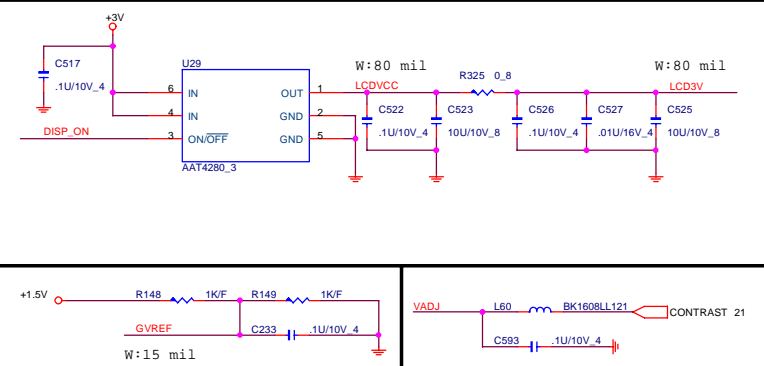
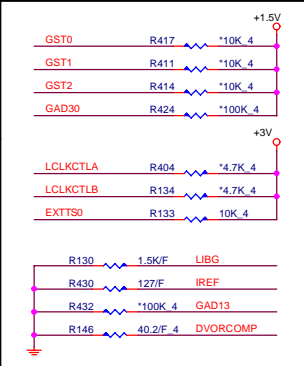
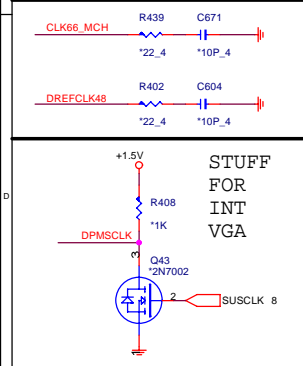
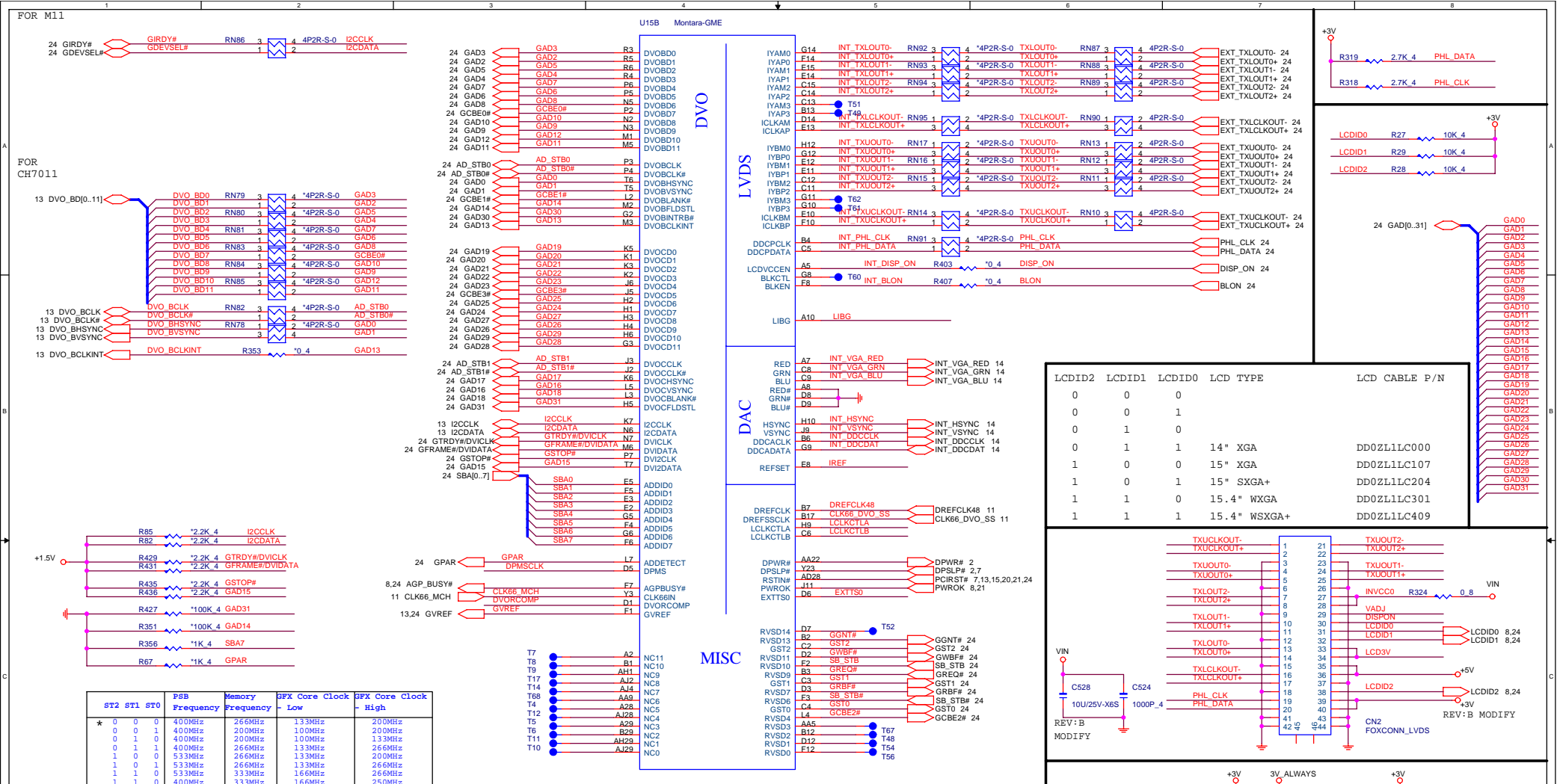

LCDID2	LCDID1	LCDID0	LCD TYPE	LCD CABLE P/N
0	0	0		
0	0	1		
0	1	0		
0	1	1	14" XGA	DD0ZLLC000
1	0	0	15" XGA	DD0ZLLC107
1	0	1	15" SXGA+	DD0ZLLC204
1	1	0	15.4" WXGA	DD0ZLLC301
1	1	1	15.4" WSXGA+	DD0ZLLC409

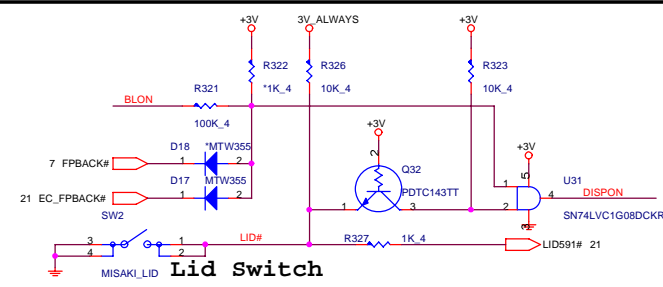
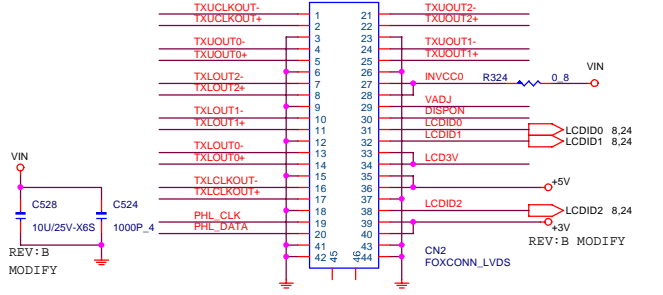

**PROJECT : ZL1**  
**Quanta Computer Inc.**

Size: Document Number  
**GMCH\_B (DVO & LVDS)**  
 Date: Friday, June 04, 2004  
 Sheet: 5 of 35  
 Rev: 82B

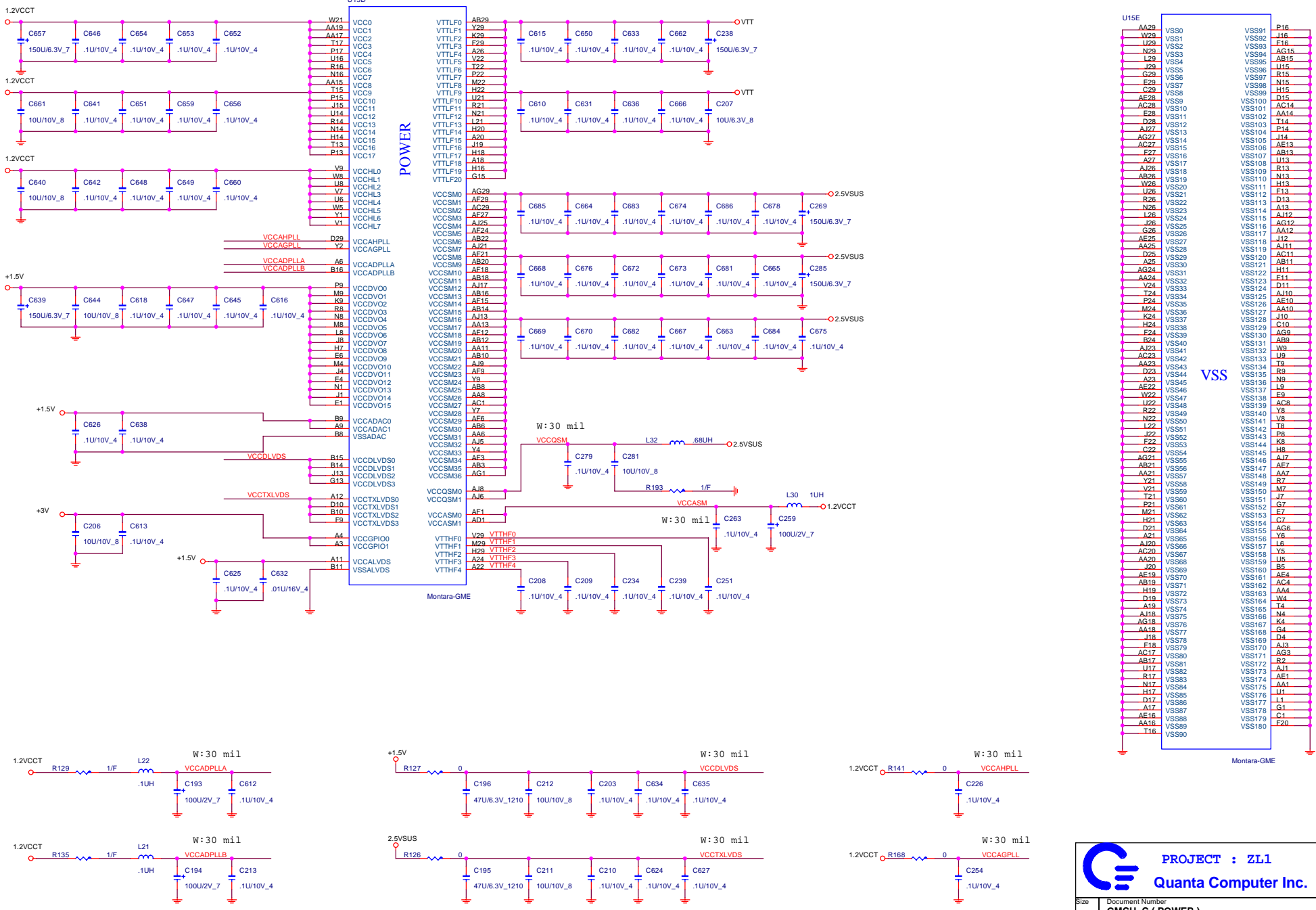

**PROJECT : ZL1**  
**Quanta Computer Inc.**

Size	Document Number	Rev
	<b>GMCH_C ( POWER )</b>	A1A
Date:	Friday, June 04, 2004	Sheet 6 of 35



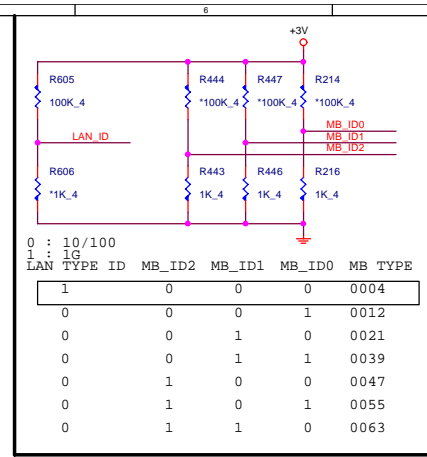
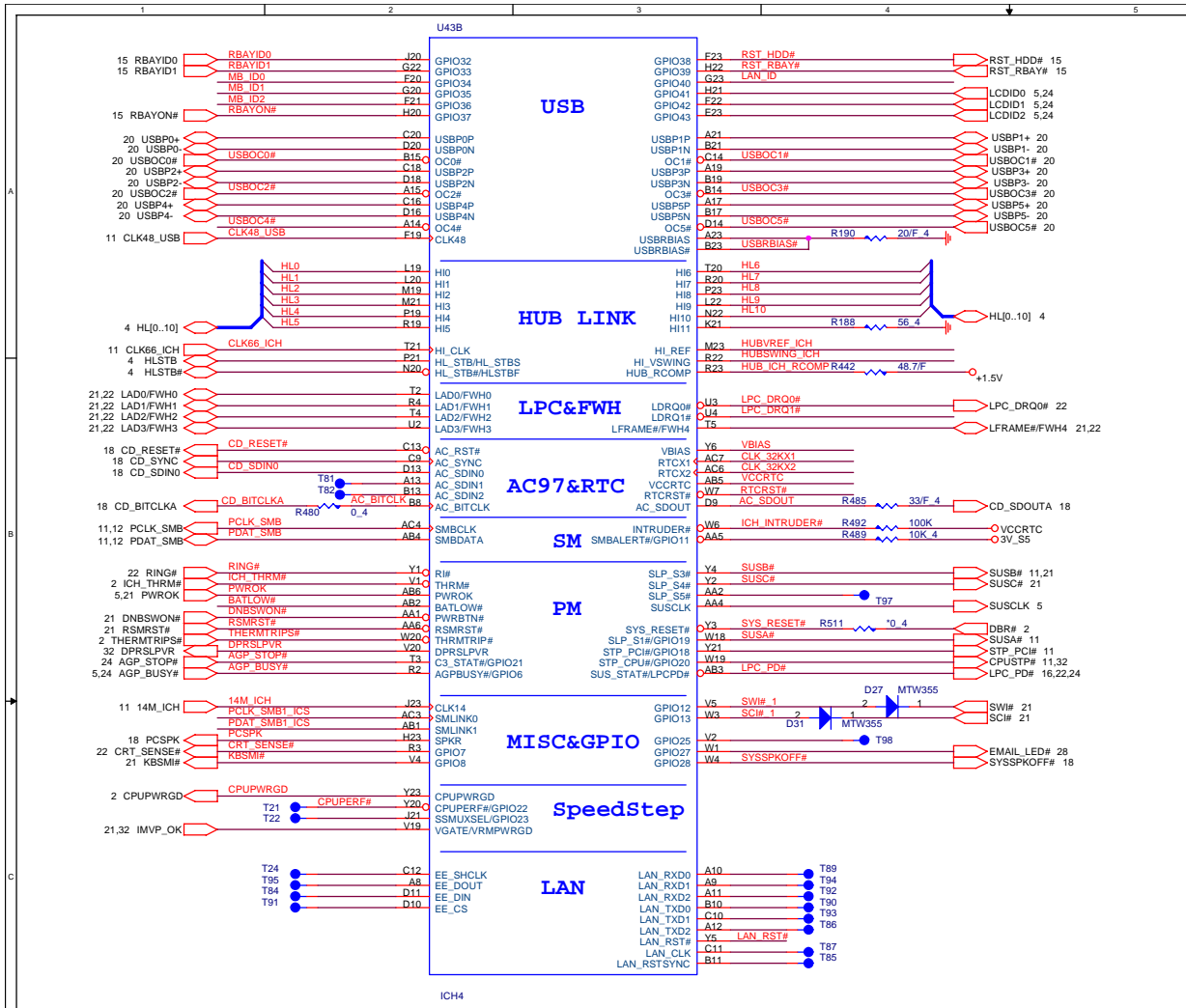

0 : 10/100  
1 : 1G

LAN TYPE	ID	MB_ID2	MB_ID1	MB_ID0	MB TYPE
1	0	0	0	0	0004
0	0	0	1	0	0012
0	0	1	0	0	0021
0	0	1	1	0	0039
0	1	0	0	0	0047
0	1	0	1	0	0055
0	1	1	0	0	0063

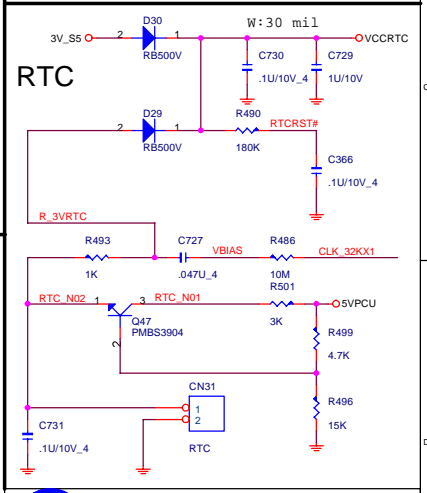
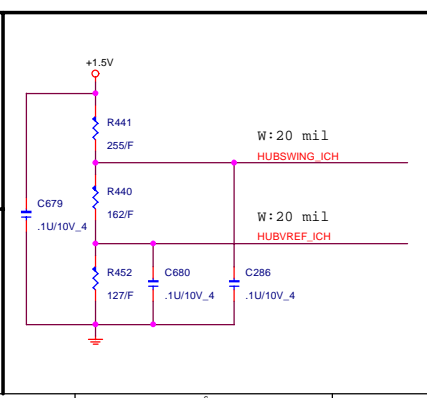
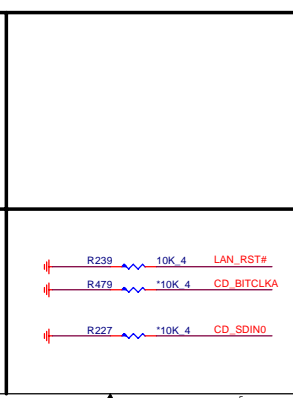
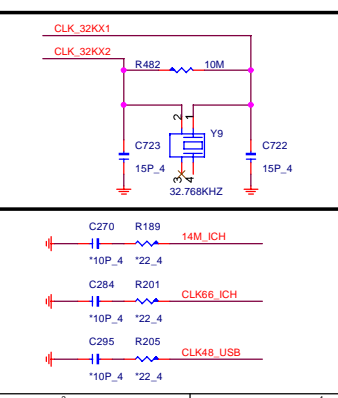
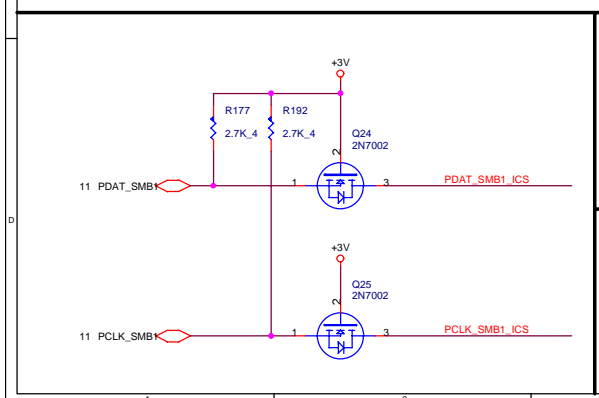
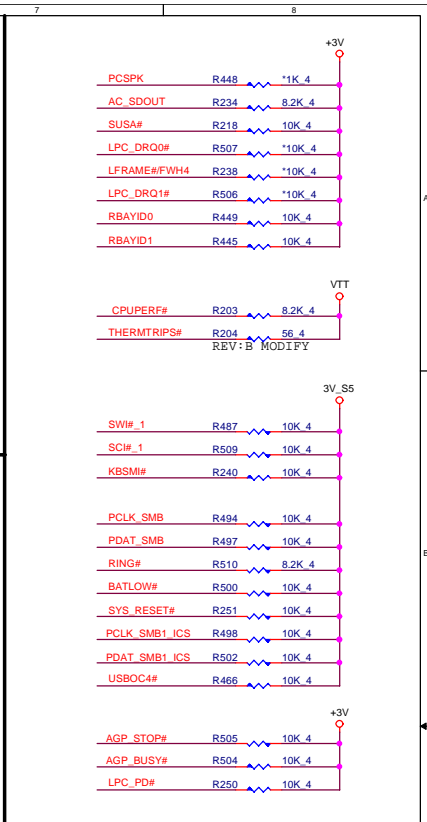



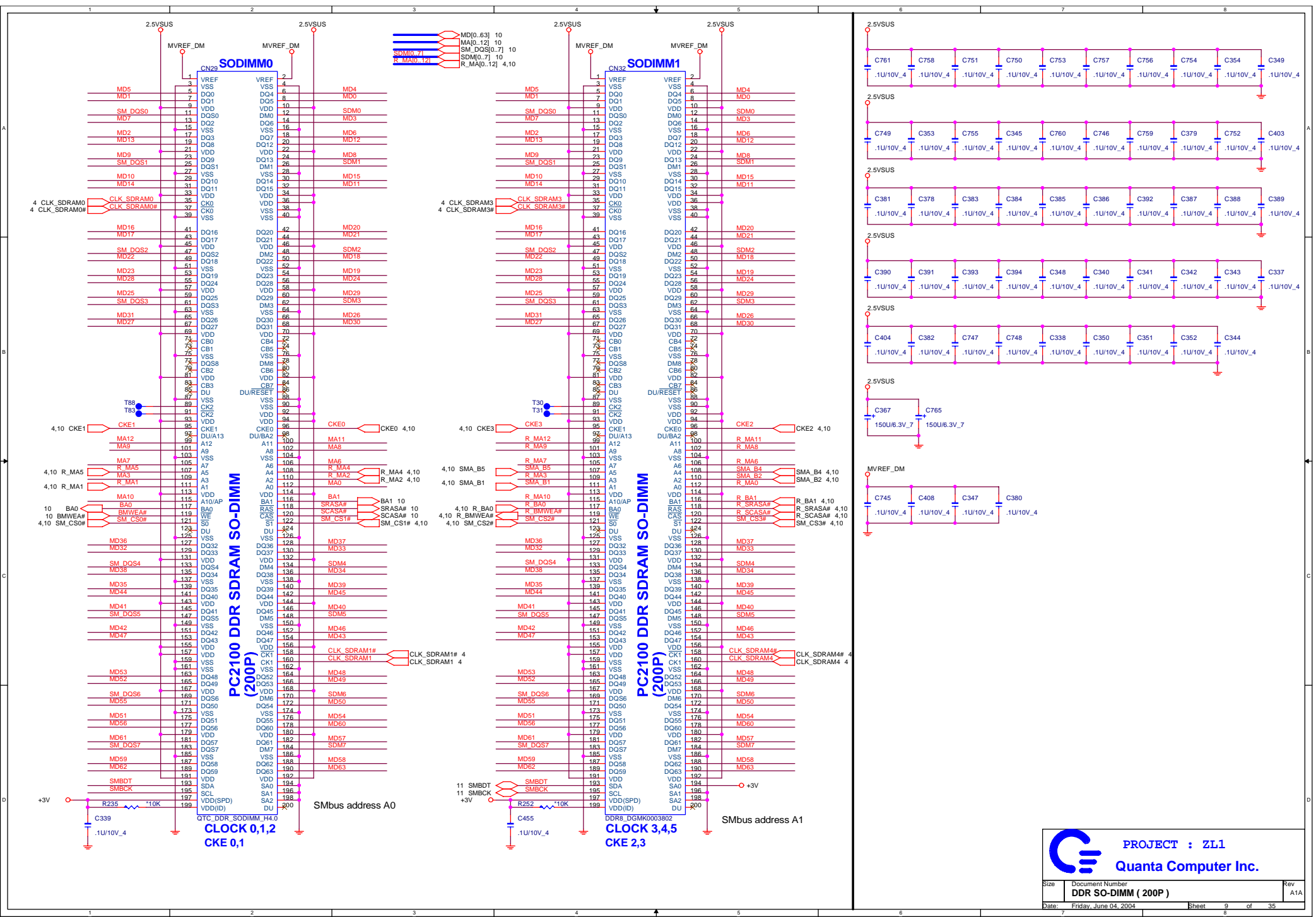

**PROJECT : ZL1**  
**Quanta Computer Inc.**

Size	Document Number	Rev
	<b>DDR SO-DIMM ( 200P )</b>	A1A

Date: Friday, June 04, 2004 Sheet 9 of 35

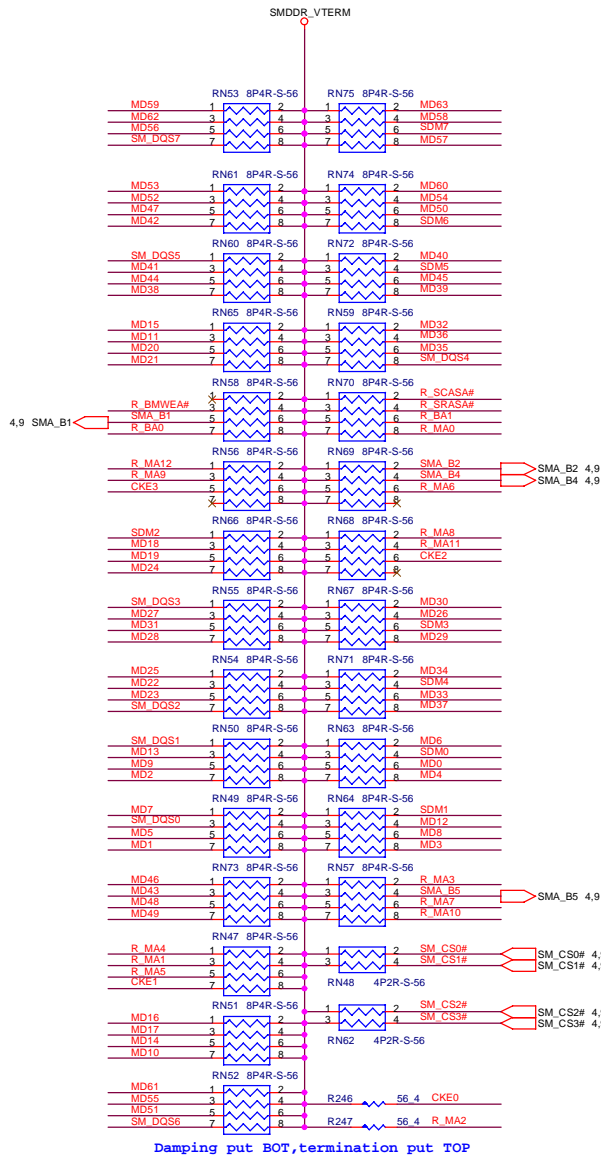

4.9 SMA\_B1

SMA\_B2 4.9  
SMA\_B4 4.9

SMA\_B5 4.9

SM\_CS0# 4.9  
SM\_CS1# 4.9

SM\_CS2# 4.9  
SM\_CS3# 4.9

Damping put BO7, termination put TOP

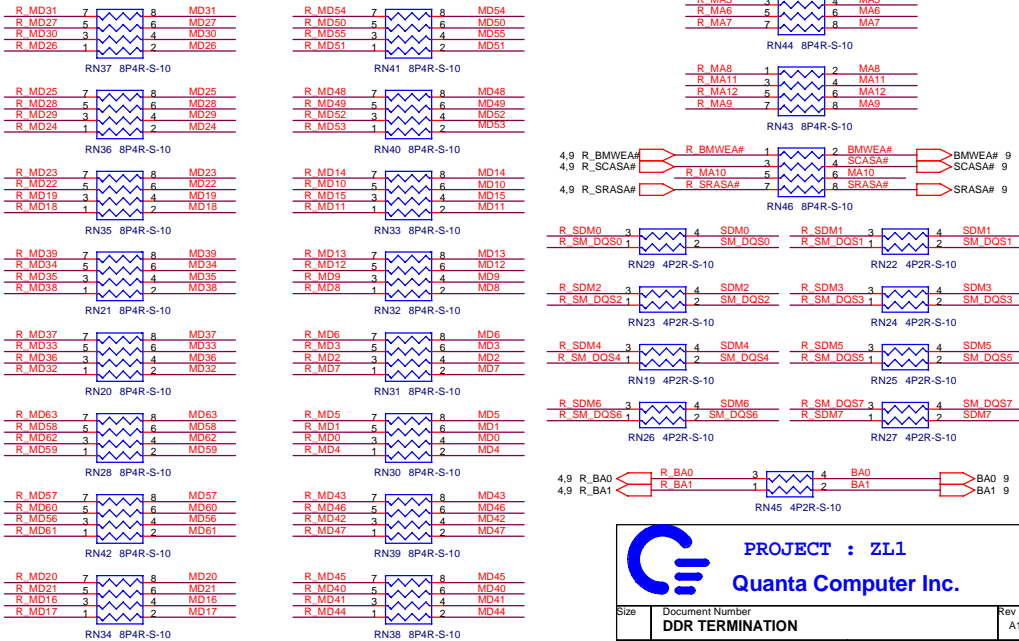
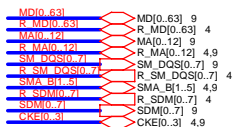

For terminal R-pack.



**PROJECT : ZL1**  
**Quanta Computer Inc.**

Size	Document Number	Rev
	<b>DDR TERMINATION</b>	A1A
Date:	Friday, June 04, 2004	Sheet 10 of 35

S2	S1	S0	CPU	3V66[0..4]	3V66_5/66IN
1	0	0	66	66IN	66 Input
1	0	1	100	66IN	66 Input
1	1	0	200	66IN	66 Input
1	1	1	133	66IN	66 Input
0	0	0	66	66	66
0	0	1	100	66	66
0	1	0	200	66	66
0	1	1	133	66	66

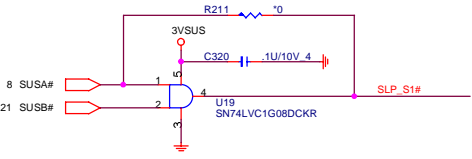
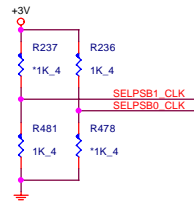

3V66\_1/VCH  
 SMBus Byte 0 , Bit 5 = 0    66 MHz    W    S/S  
 SMBus Byte 0 , Bit 5 = 1    48 MHz    W/O S/S

Byte 0 , Bit 7 = 0    Disable Spread Spectrum  
 Byte 0 , Bit 7 = 1    Enable Spread Spectrum

Byte 4 Bit 7	Byte 5 Bit 7	Byte 5 Bit 6	Spread Mode	Spread %
SS2	SS1	SS0		
0	0	0	DOWN	+0.00 , -0.25
0	0	1	DOWN	+0.00 , -0.50
0	1	0	DOWN	+0.00 , -0.75
0	1	1	DOWN	+0.00 , -1.00
1	0	0	CENTER	+0.13 , -0.13
1	0	1	CENTER	+0.25 , -0.25
1	1	0	CENTER	+0.37 , -0.37
1	1	1	CENTER	+0.50 , -1.50

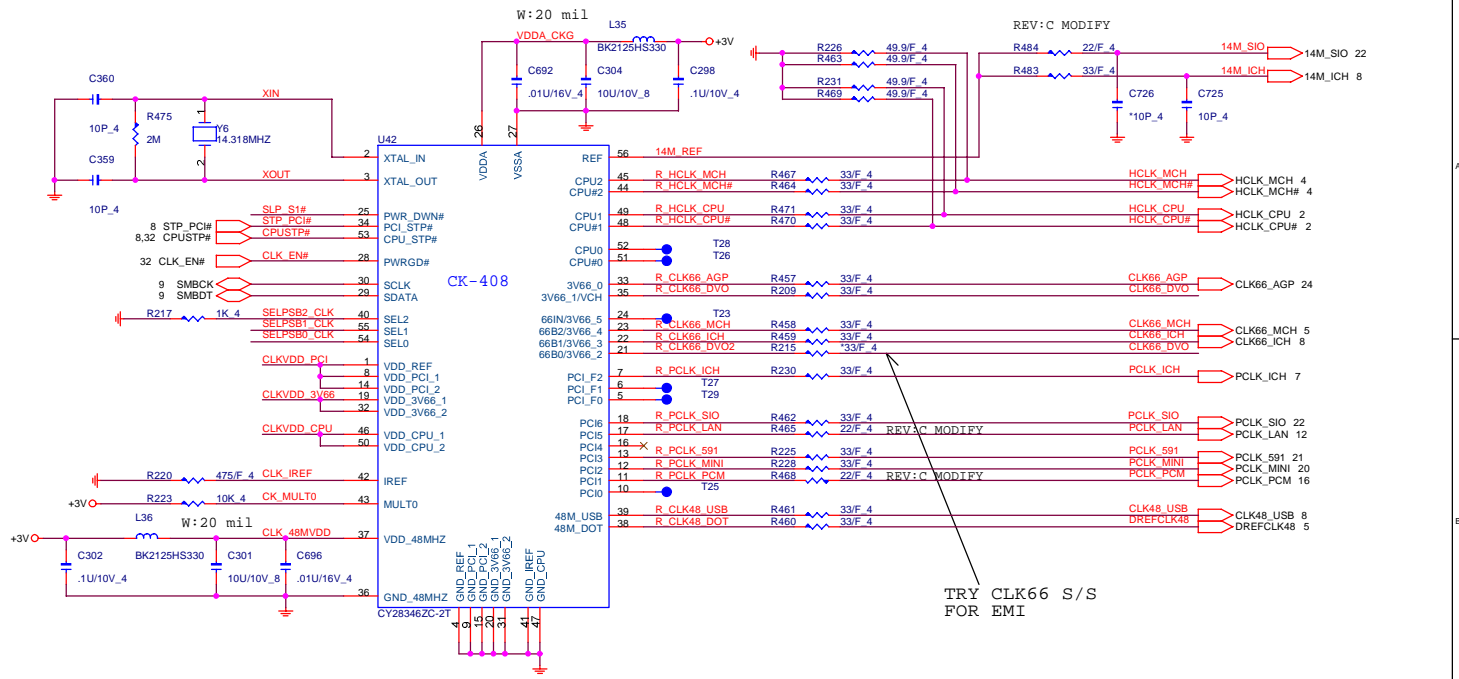

TRY CLK66 S/S FOR EMI

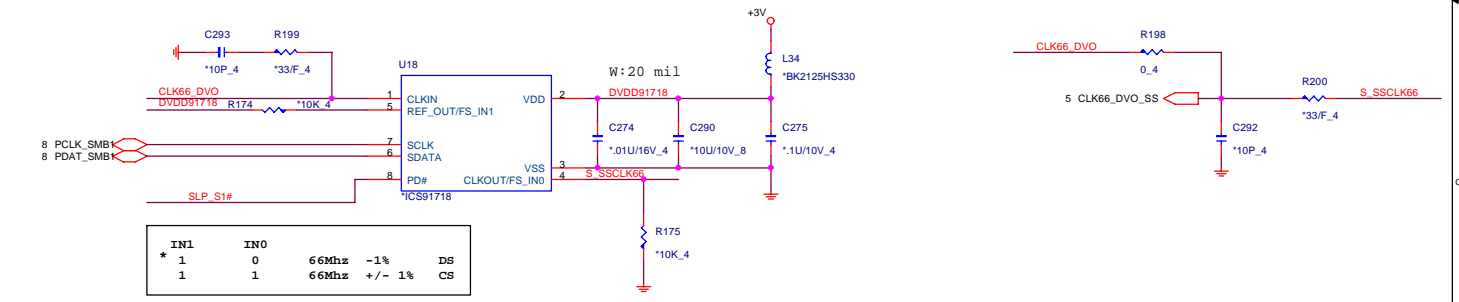

IN1	INO	66Mhz	-1%	DS
* 1	0	66Mhz	-1%	DS
1	1	66Mhz	+/- 1%	CS

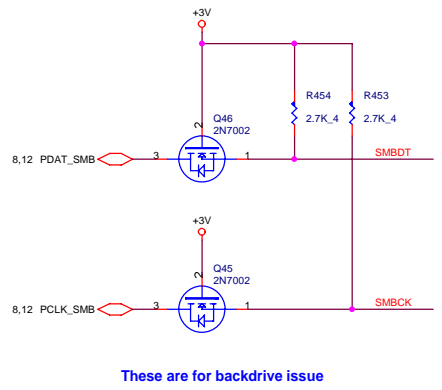

These are for backdrive issue

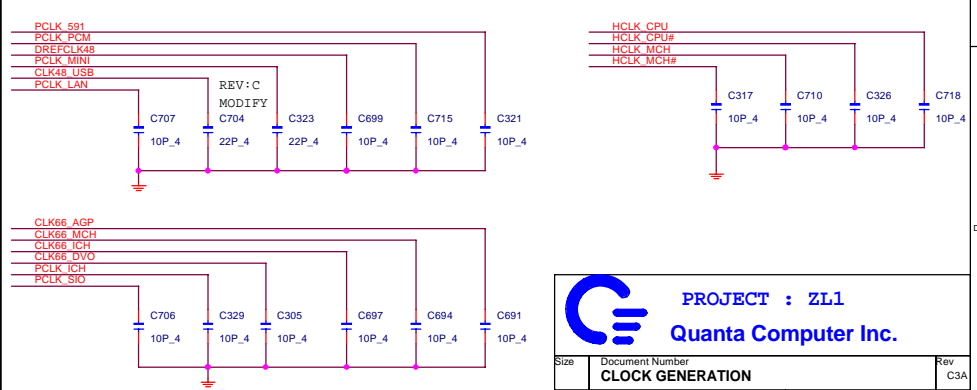
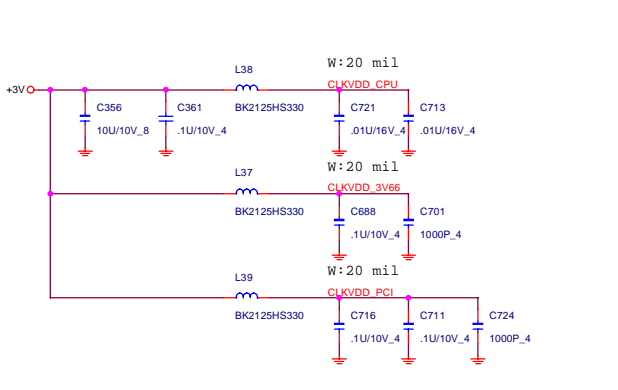

**PROJECT : ZL1**  
**Quanta Computer Inc.**

Size: Document Number: **CLOCK GENERATION** Rev: C3A  
 Date: Friday, June 04, 2004 Sheet: 11 of 35

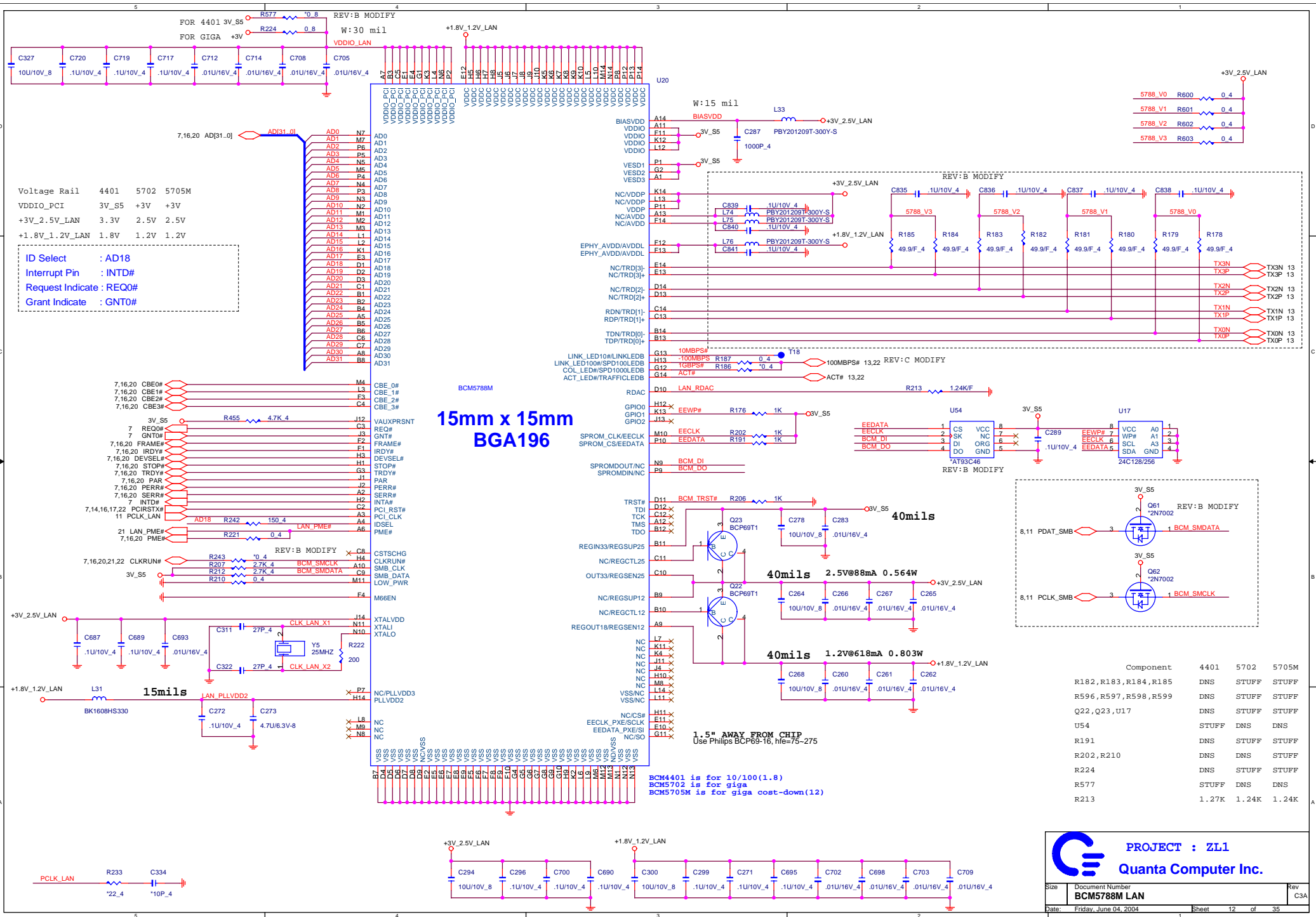

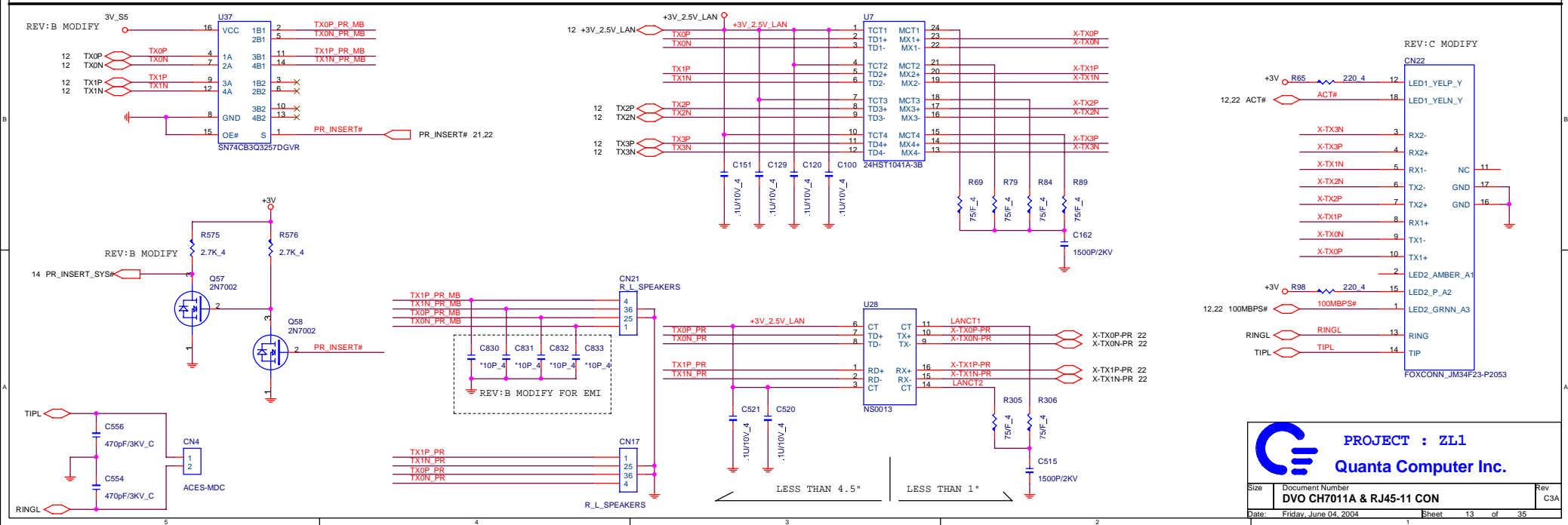
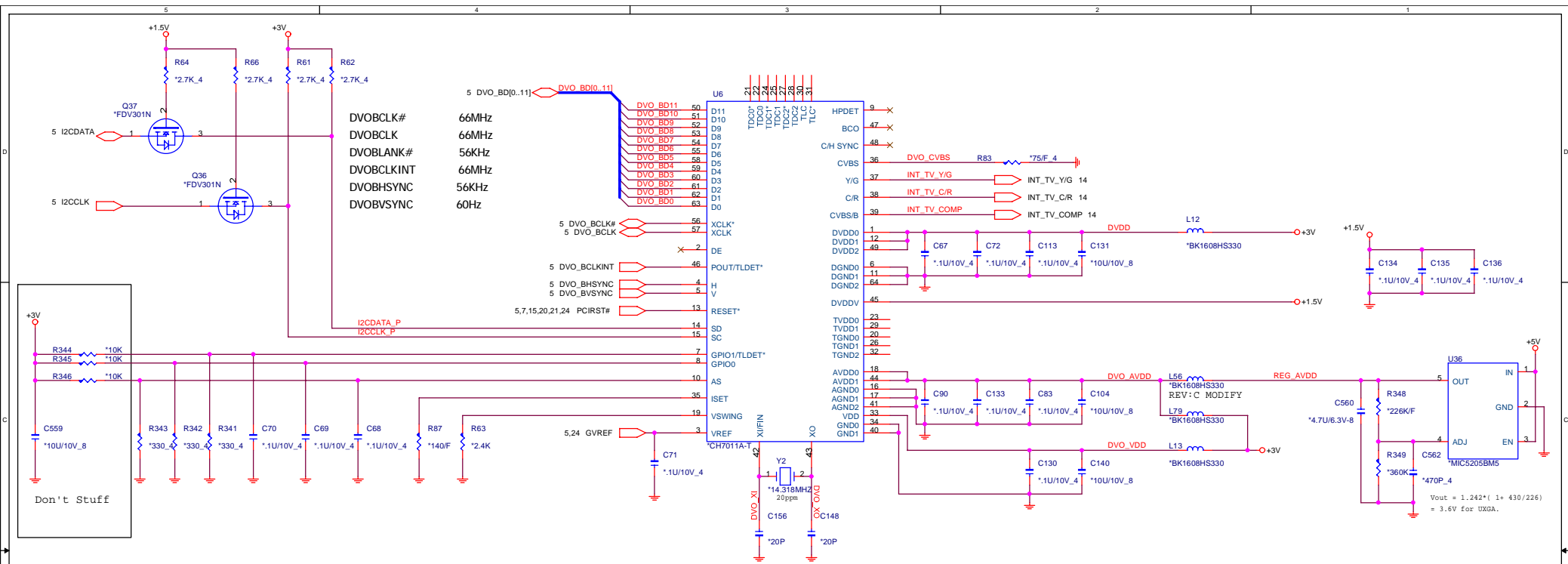

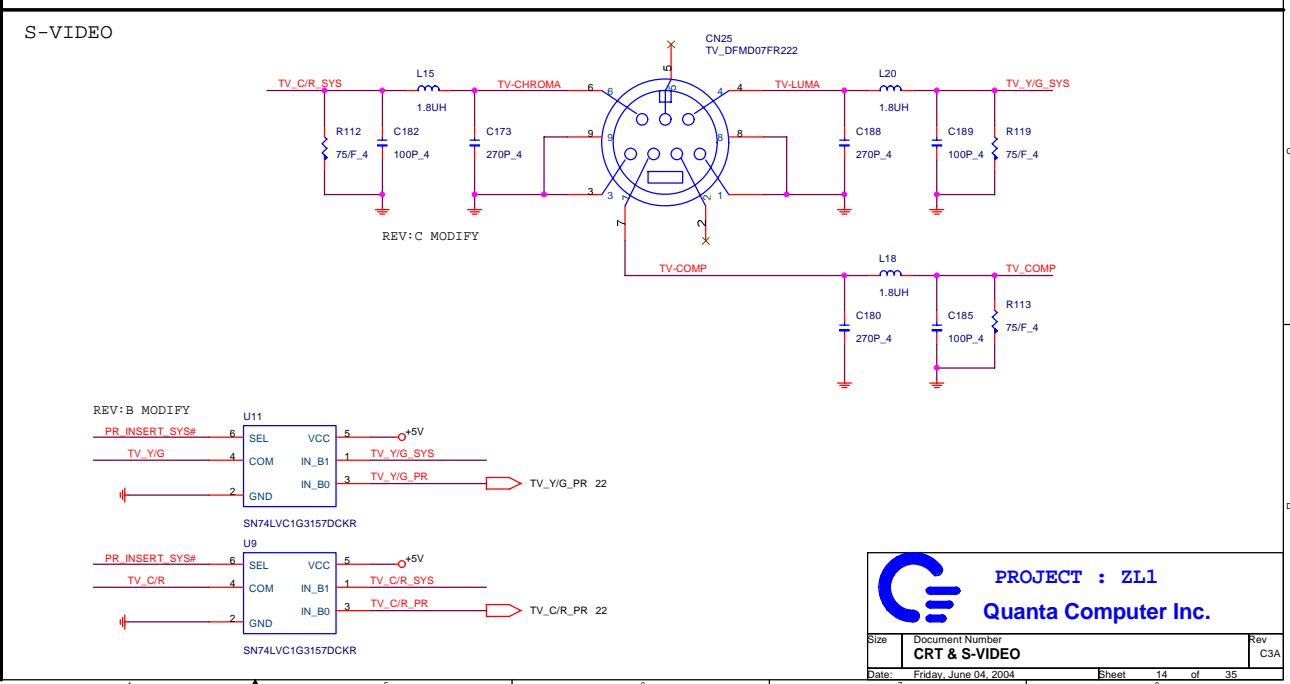
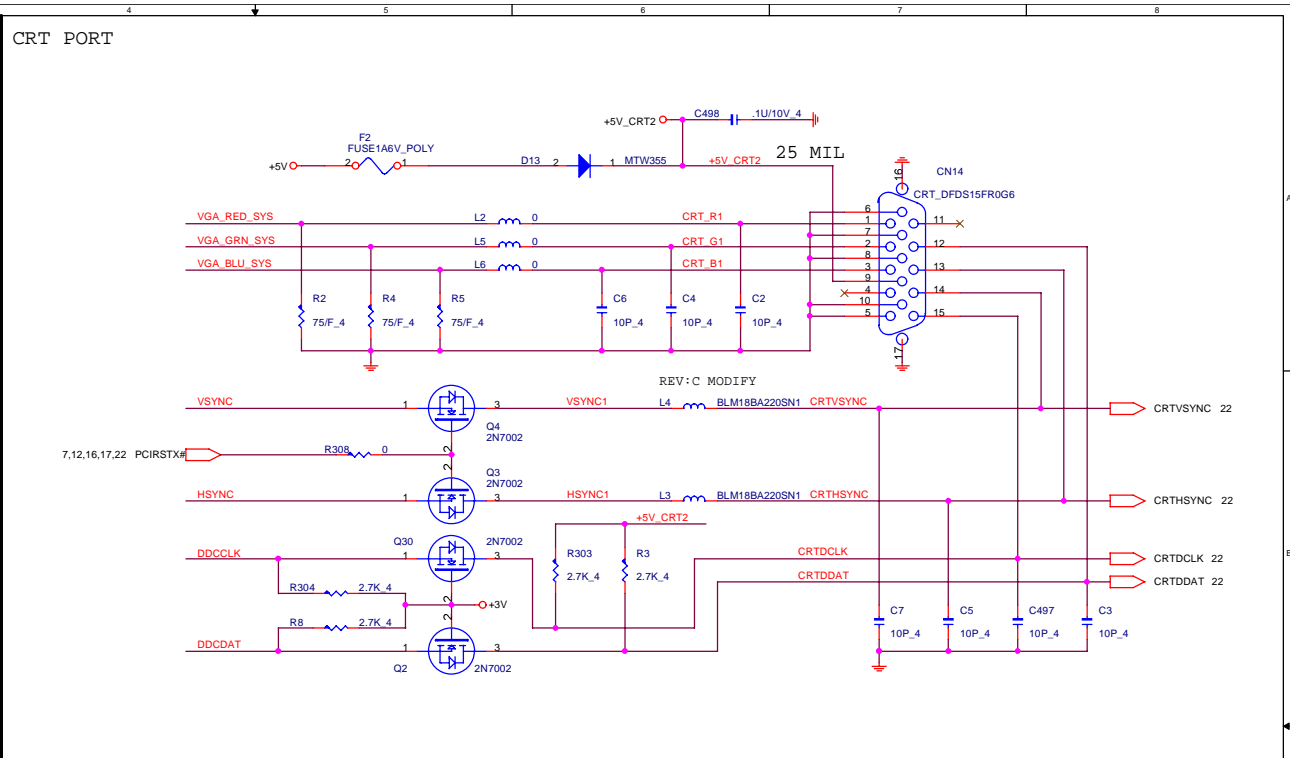
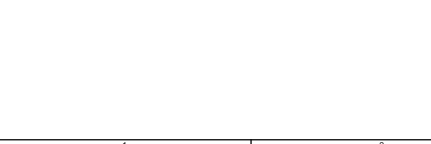
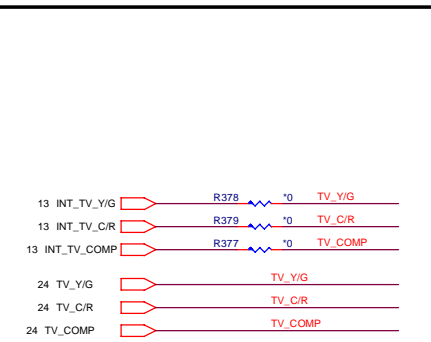
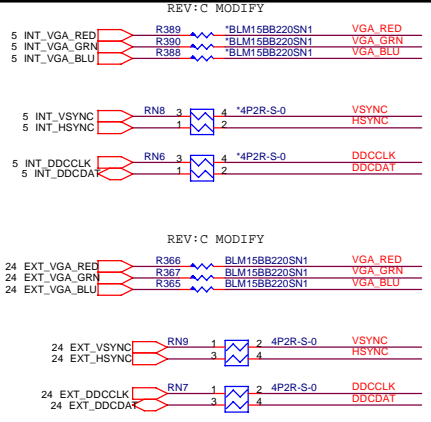
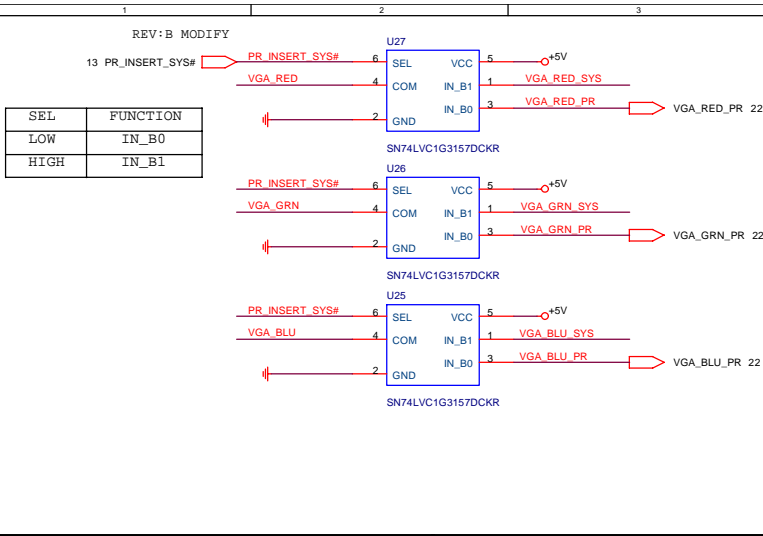

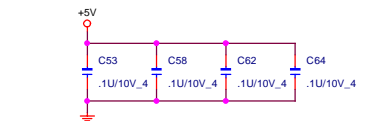
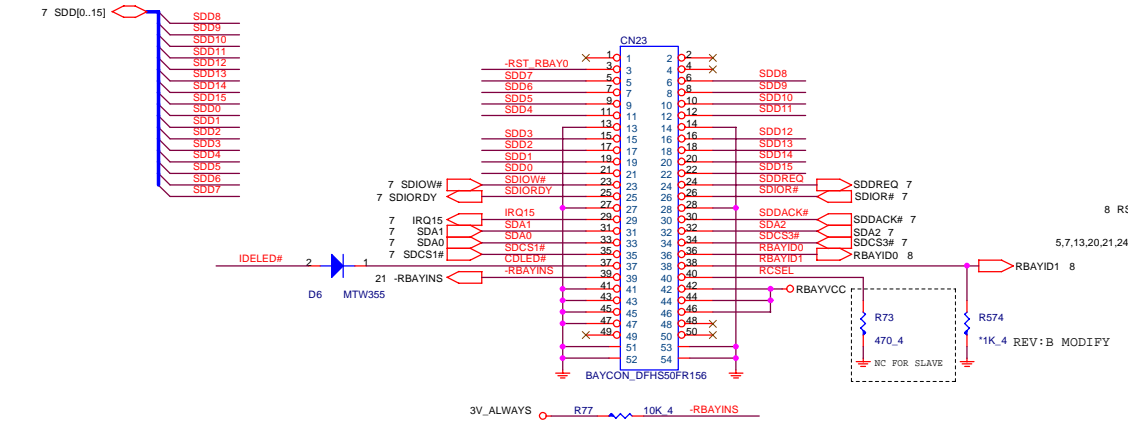
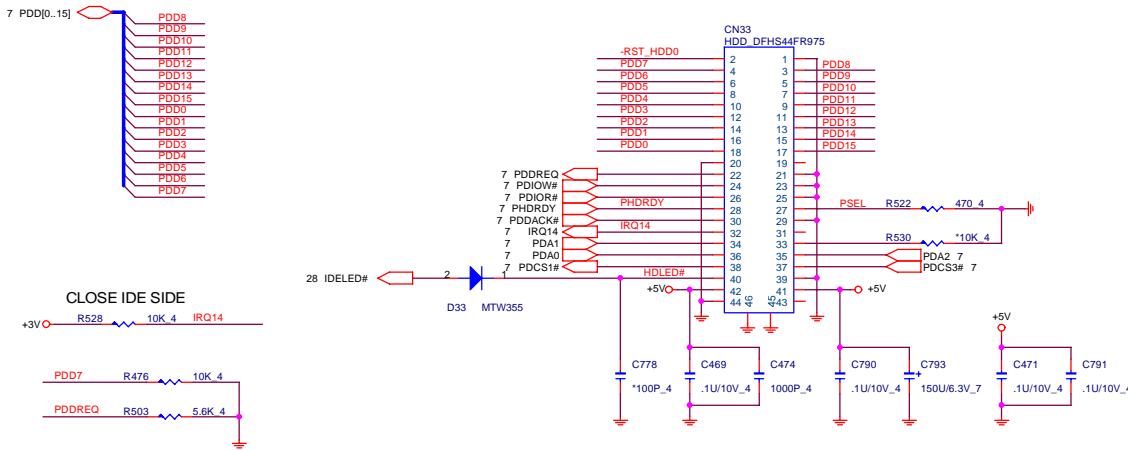

**BAY ID STATUS**

RBAYID0/ LBAYID0	RBAYID1/ LBAYID1	STATUS
0	0	FDD
0	1	HDD
1	0	CD/DVD

- W/O Media Bay
- W Media Bay
- R472, R473 DNS STUFF
- R94, R96 DNS STUFF
- R474, R101 STUFF DNS
- R48, R50 STUFF DNS
- Q10, Q35 DNS STUFF
- R340, C553 DNS STUFF
- R73, CN23 DNS STUFF
- R51, CN19 STUFF DNS
- R574 STUFF DNS

**ODD Connector**

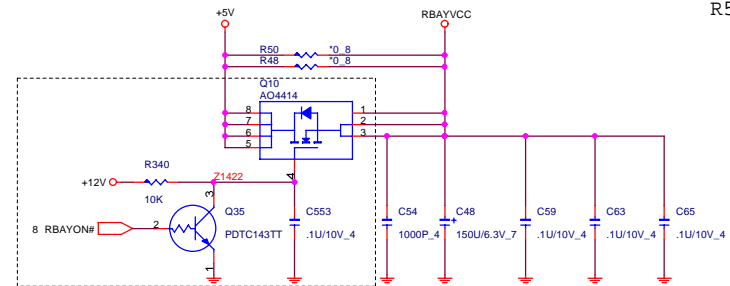
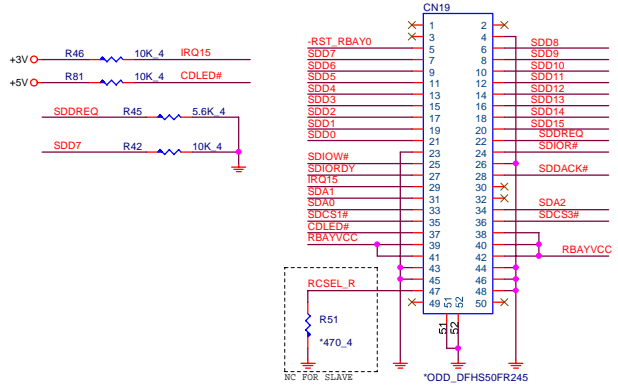

**PROJECT : ZL1**  
**Quanta Computer Inc.**

Size	Document Number	Rev
Date:	HDD & CDROM & MEDIA BAY	82B
Date:	Friday, June 04, 2004	Sheet 15 of 35

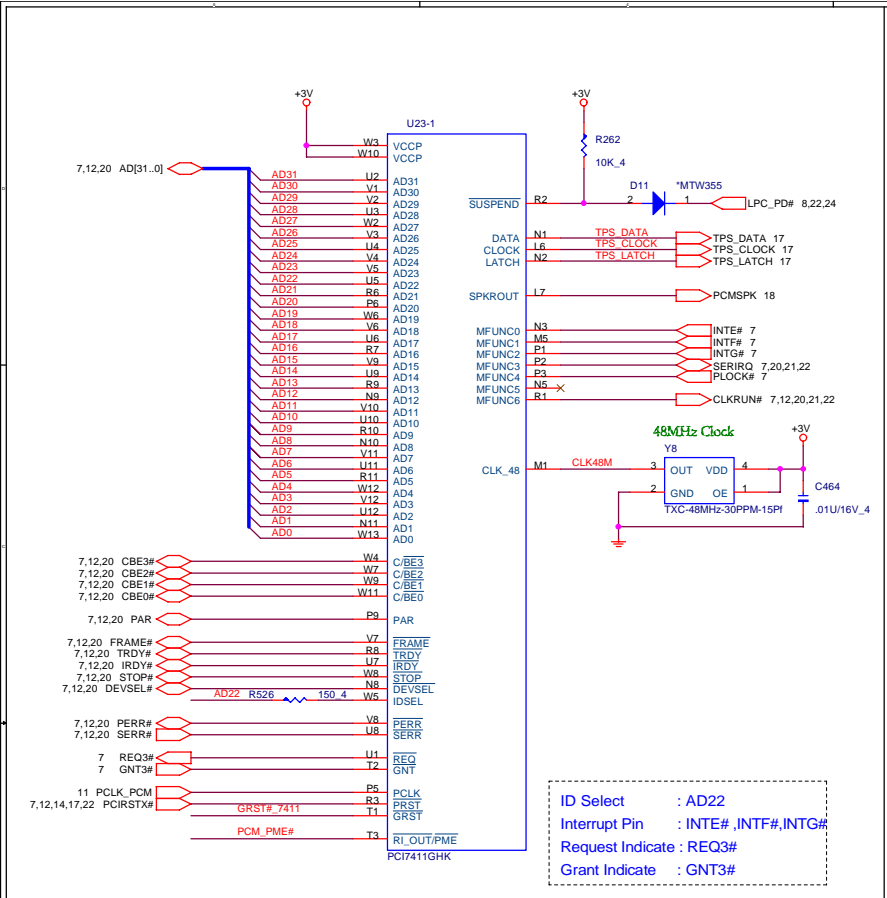

ID Select : AD22  
 Interrupt Pin : INTE# ,INTF# ,INTG#  
 Request Indicate : REQ3#  
 Grant Indicate : GNT3#

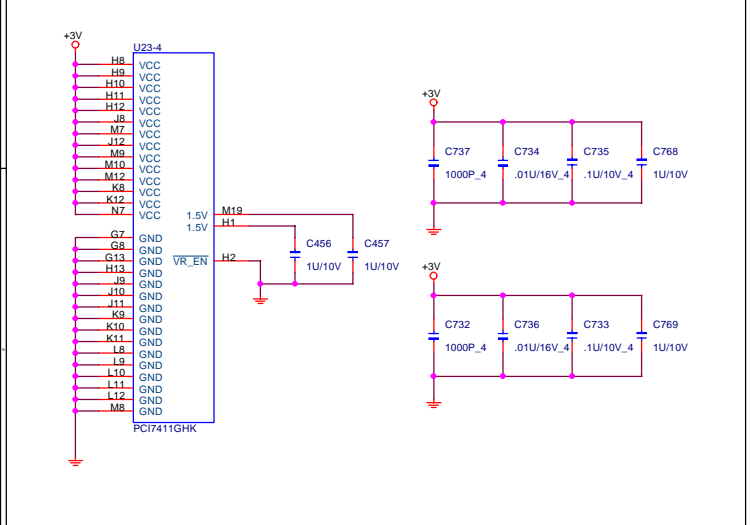
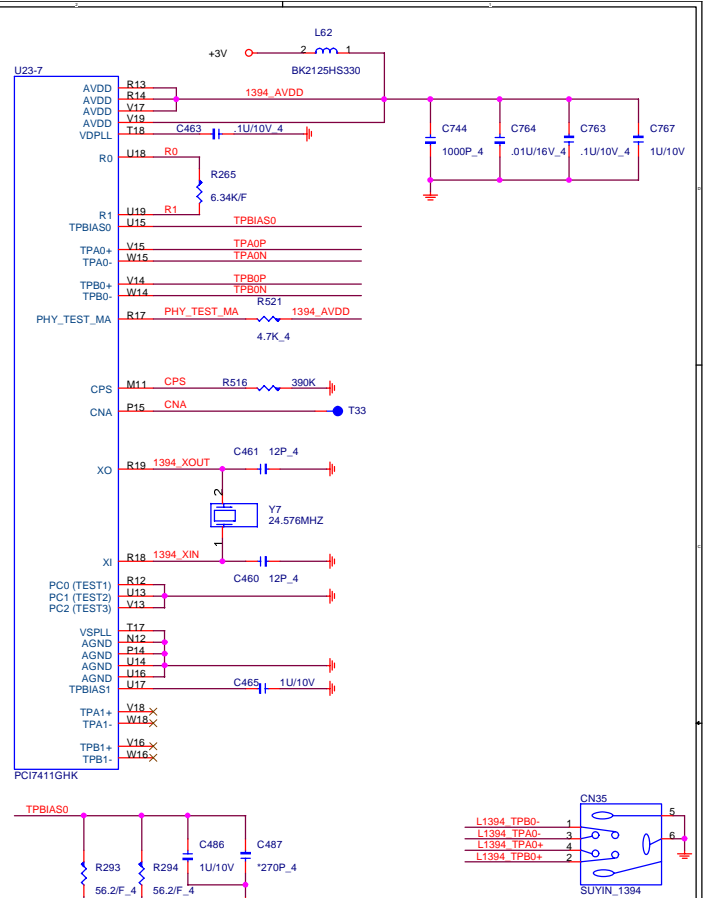
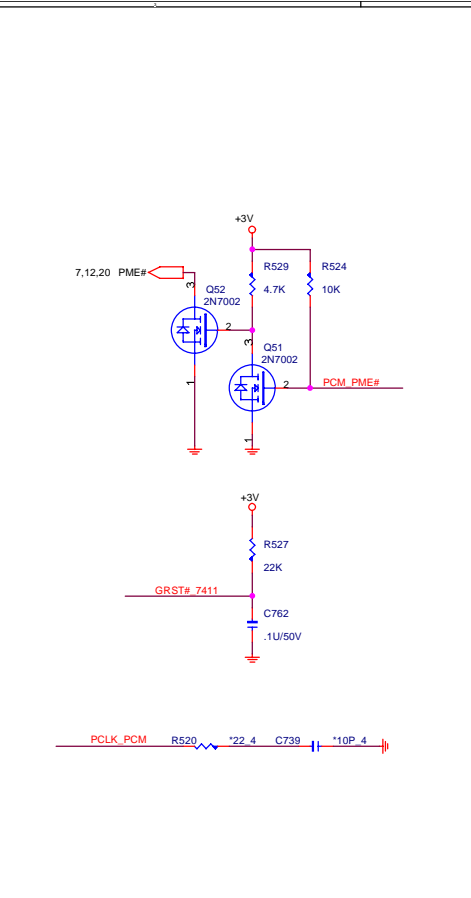



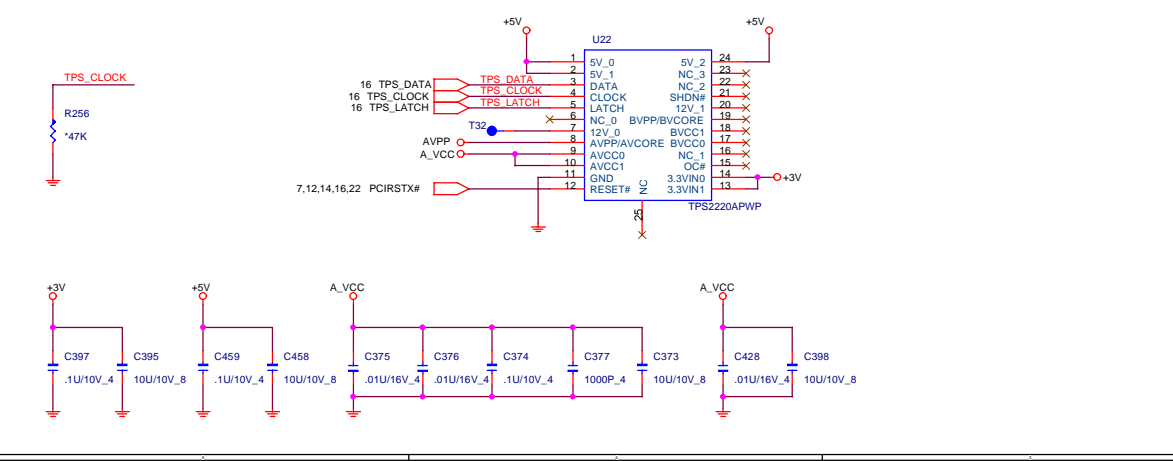
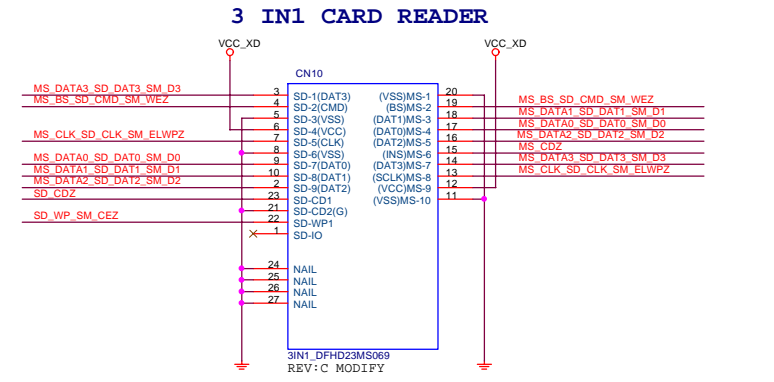
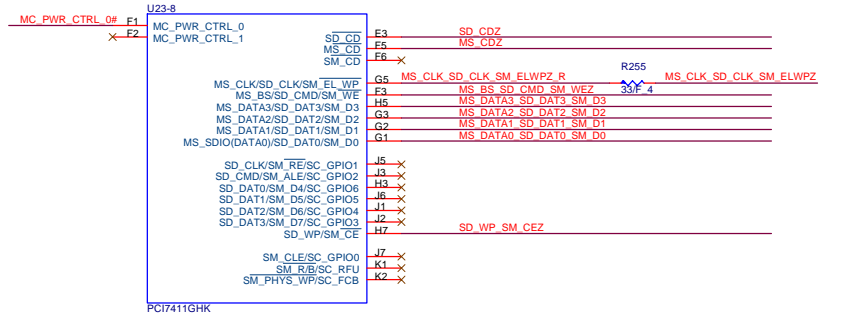
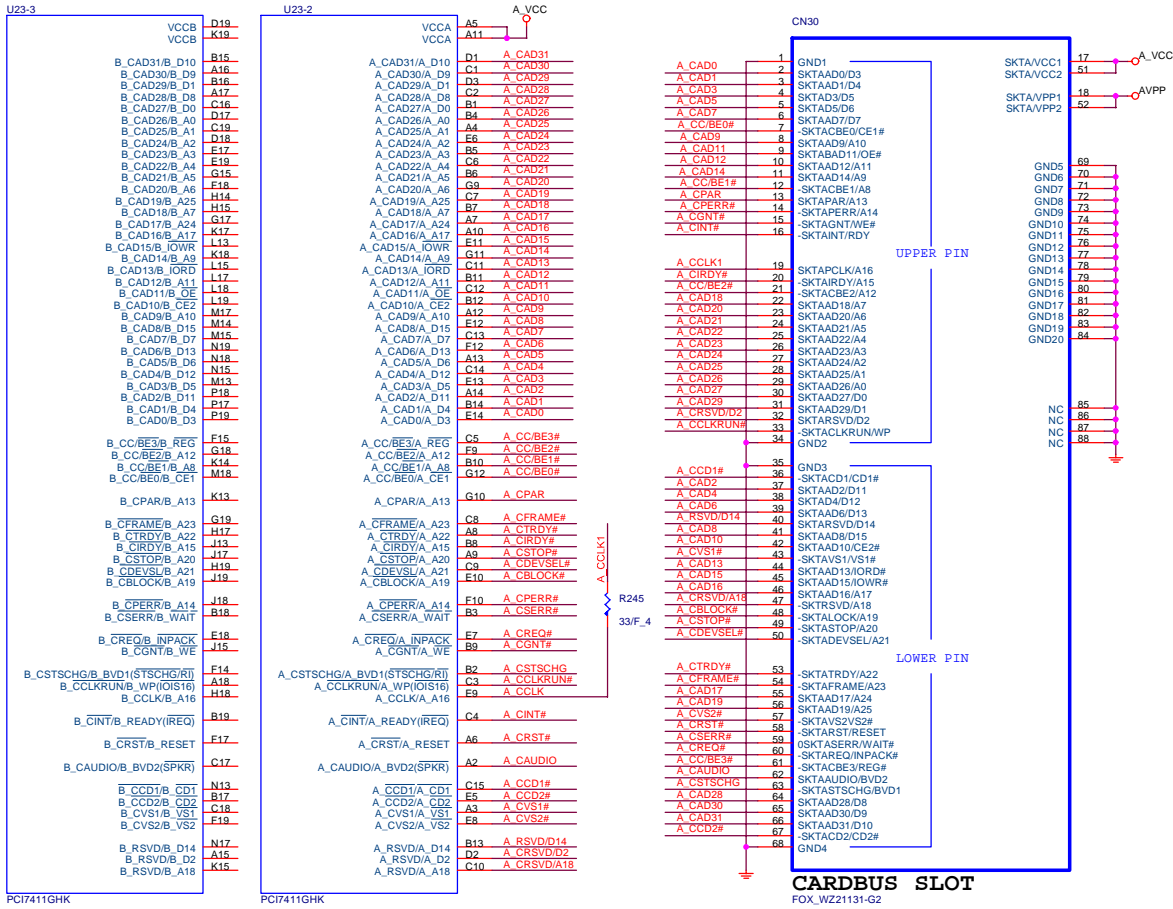



GAIN1	SPKR MODE	HP MODE
0	10.5	3
1	9	0

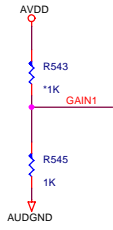

AMP POWER

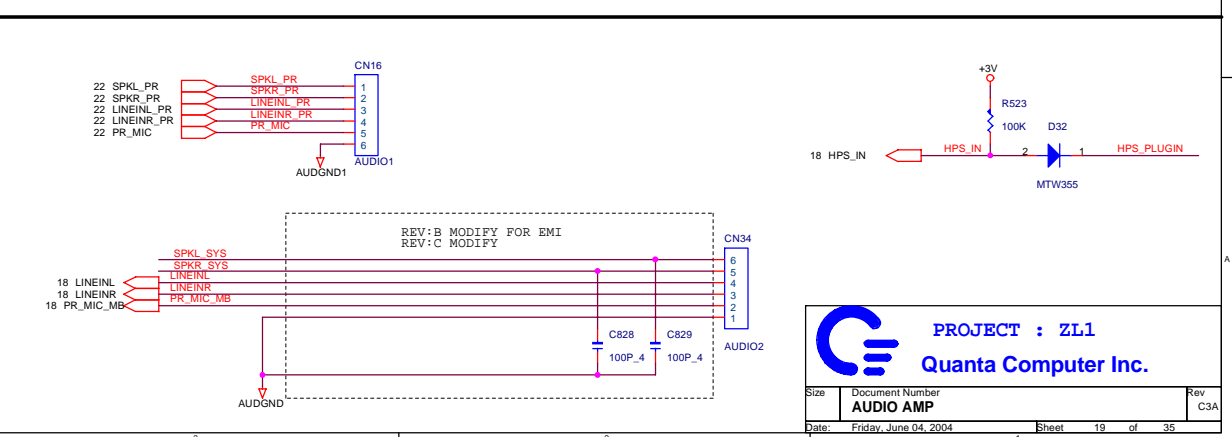
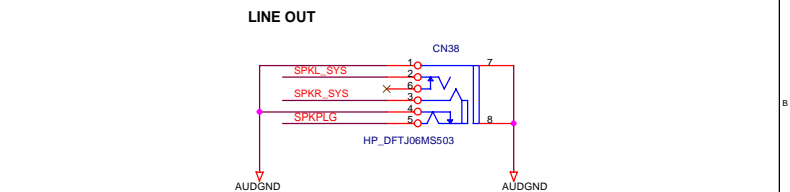
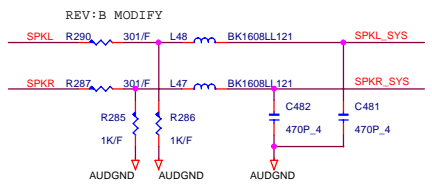
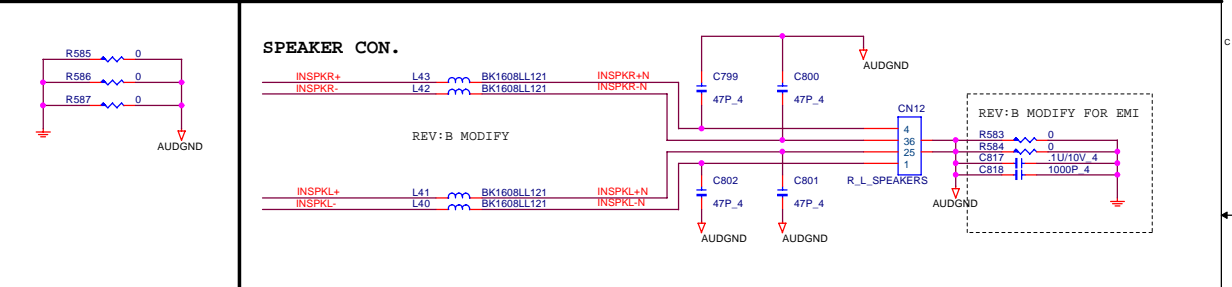
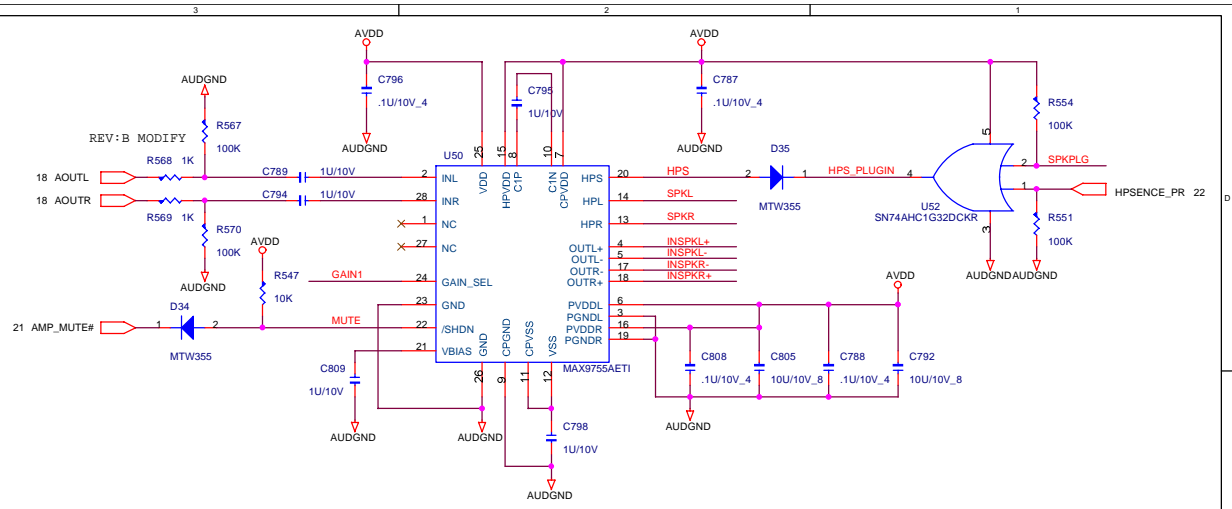
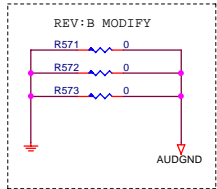
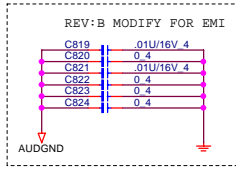
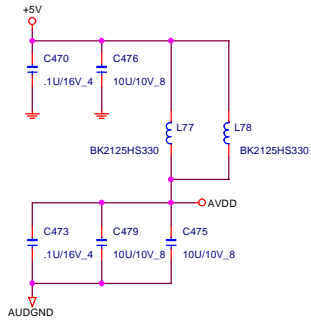

**PROJECT : ZL1**  
**Quanta Computer Inc.**

Size	Document Number	Rev
	<b>AUDIO AMP</b>	C3A
Date:	Friday, June 04, 2004	Sheet 19 of 35

LDRQ#(pin 8) internal is no use

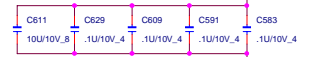
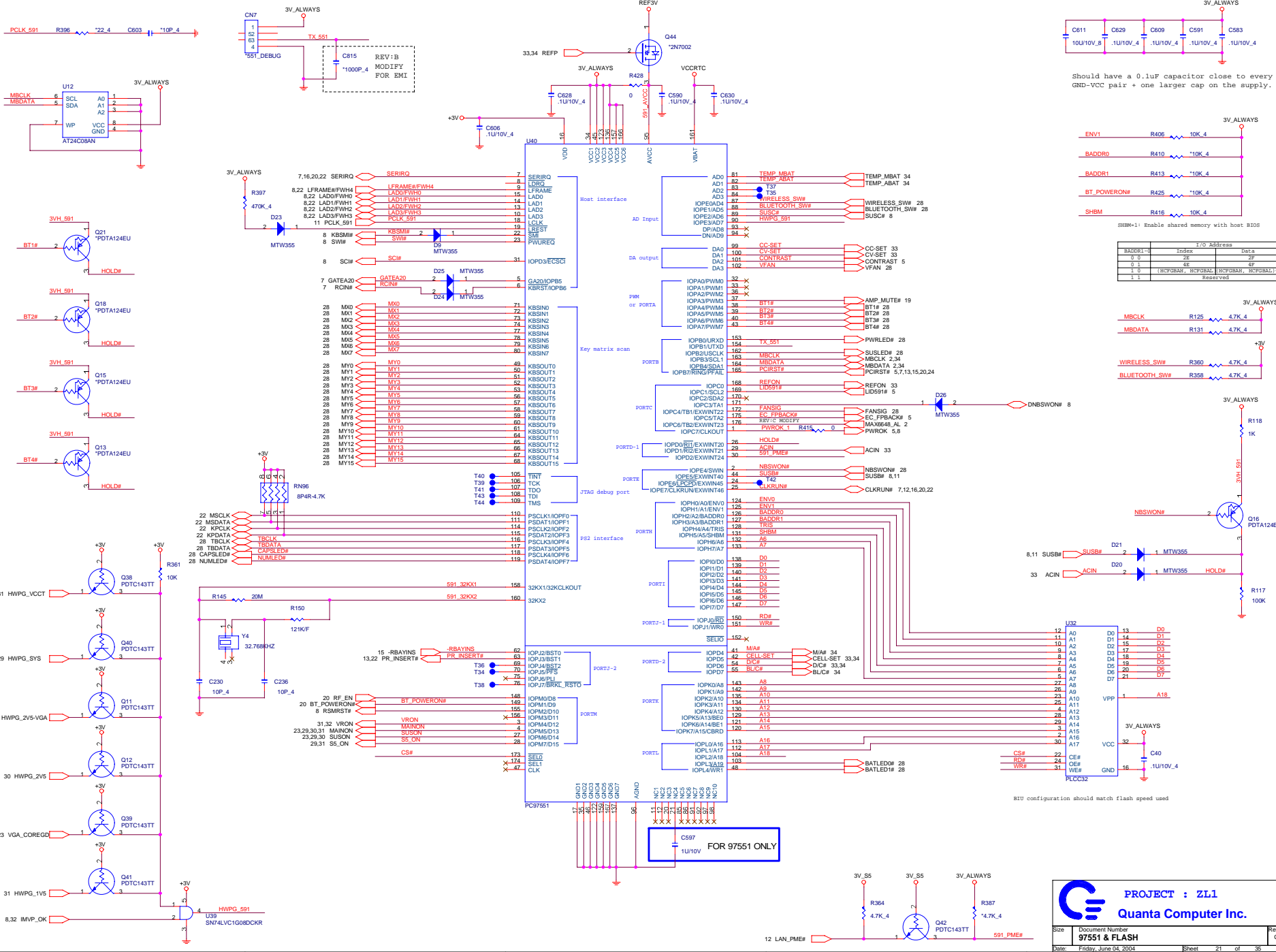

Should have a 0.1uF capacitor close to every GND-VCC pair + one larger cap on the supply.

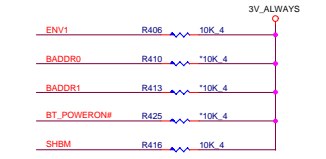

SHRM#1: Enable shared memory with host BIOS

I/O Address		
BA0R1-1	Index	Data
0 0	2E	2F
0 1	4E	4F
1 0	(Reserved)	(Reserved)
1 1	(Reserved)	(Reserved)

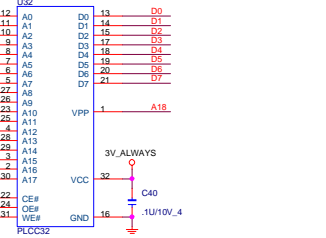
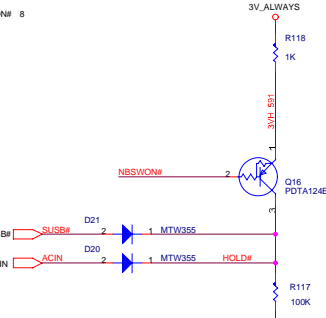
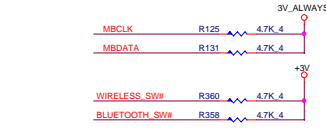

BTU configuration should match flash speed used

**PROJECT : ZL1**  
**Quanta Computer Inc.**

Size	Document Number	Rev
	<b>97551 &amp; FLASH</b>	C3A
Date	Friday, June 04, 2004	Sheet 21 of 36



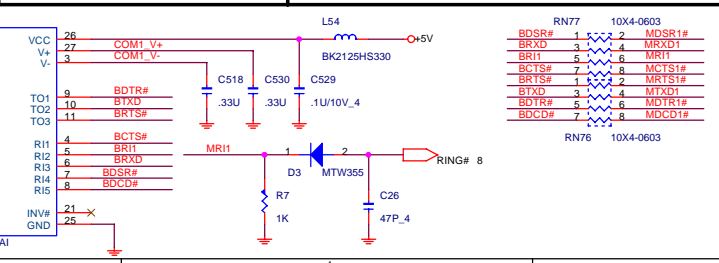
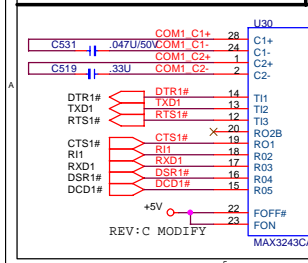
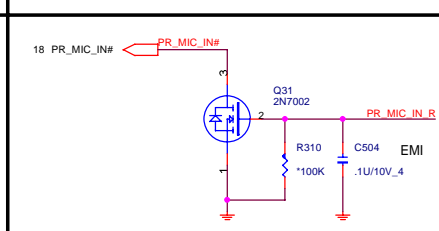
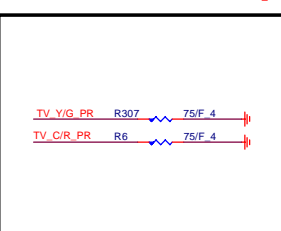
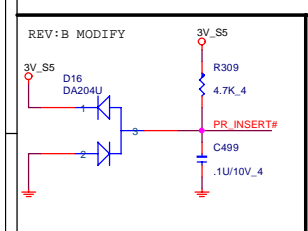
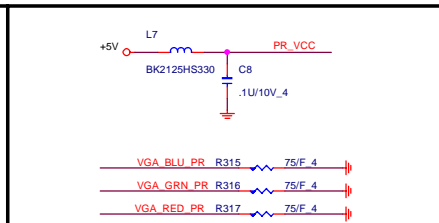
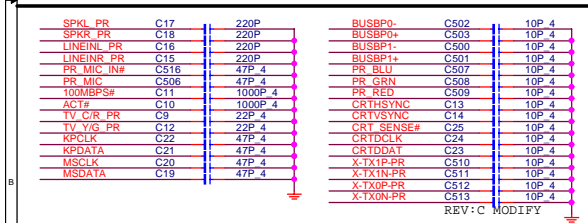
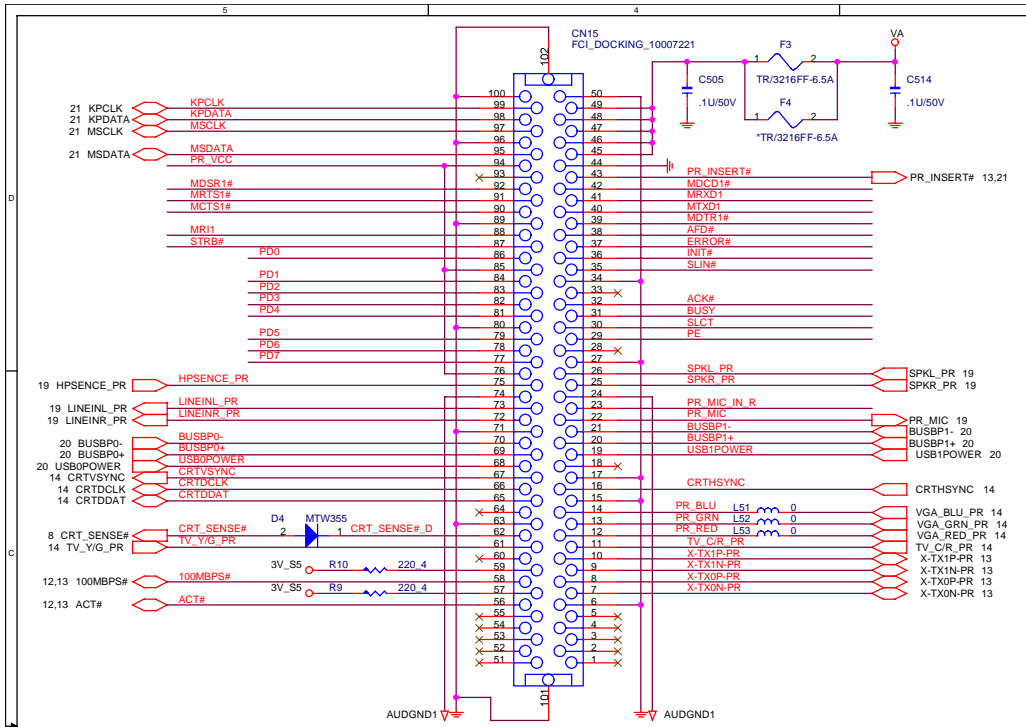

SUPER I/O

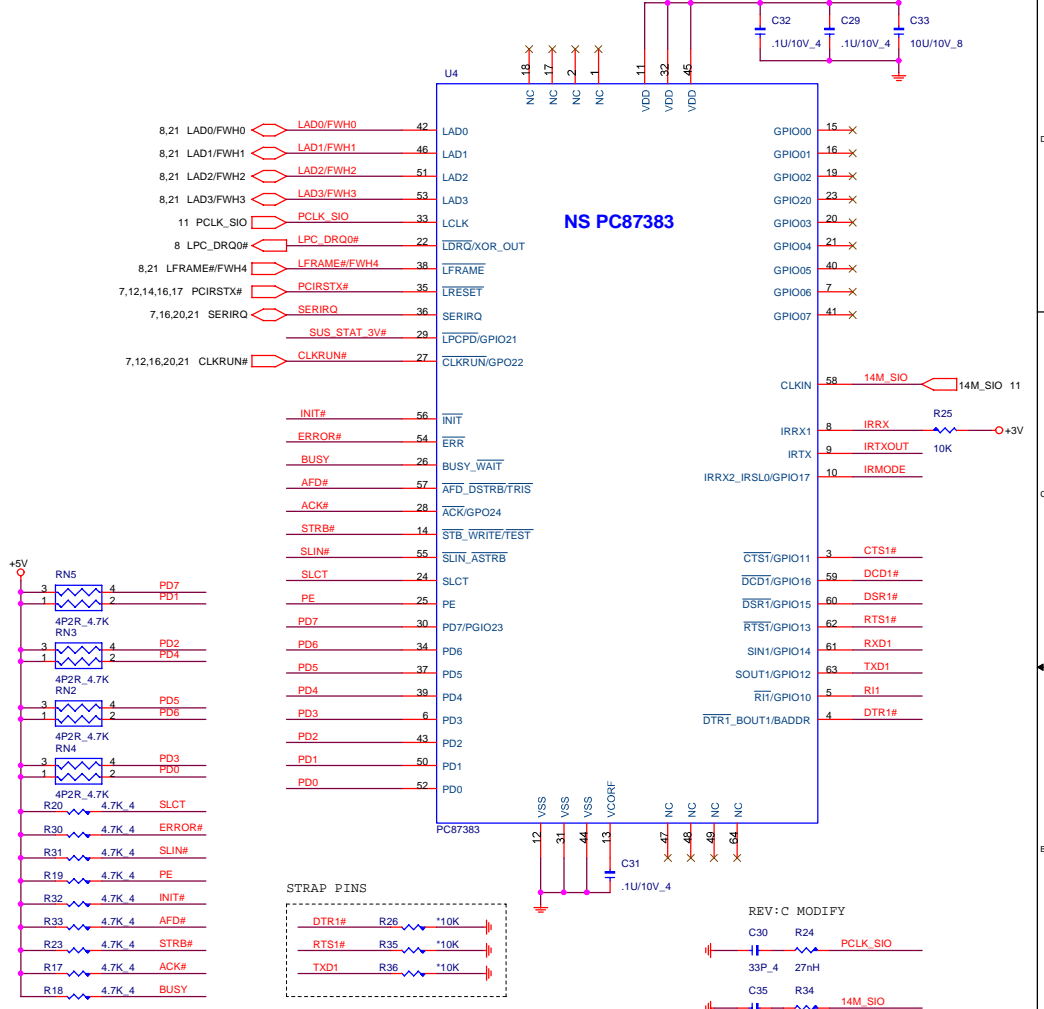

IrDA

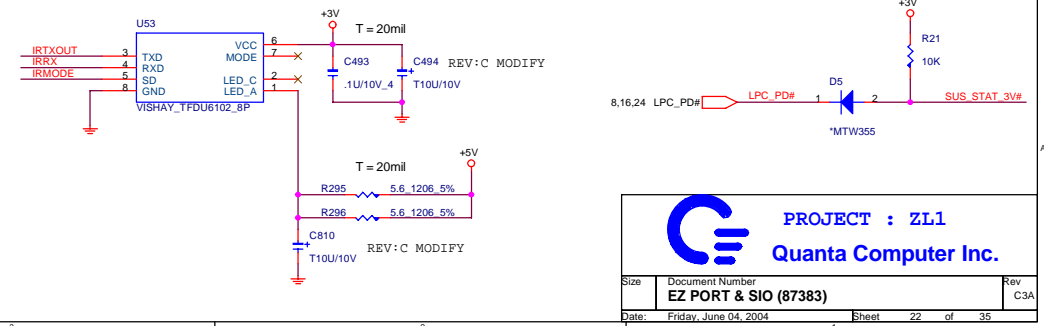

**PROJECT : ZL1**  
**Quanta Computer Inc.**

Size: Document Number  
**EZ PORT & SIO (87383)** Rev: C3A

Date: Friday, June 04, 2004 Sheet: 22 of 35

# M11 Core & BATTERY

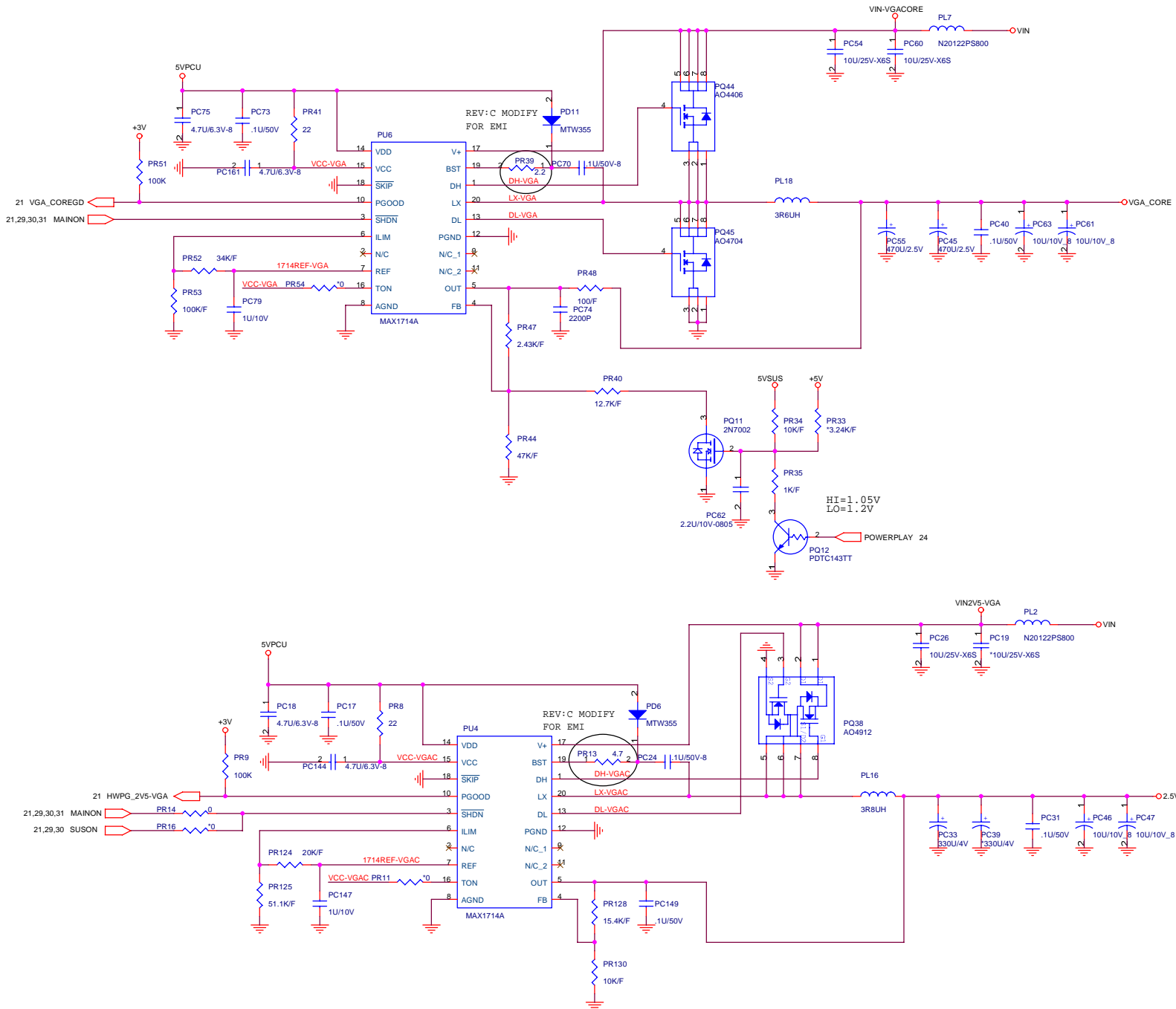

**PROJECT : ZL1**  
**Quanta Computer Inc.**

Size	Document Number	Rev
	<b>VGA CORE / VRAM POWER</b>	C3A
Date:	Friday, June 04, 2004	Sheet 23 of 35

# VGA (AGP, DISPLAY)

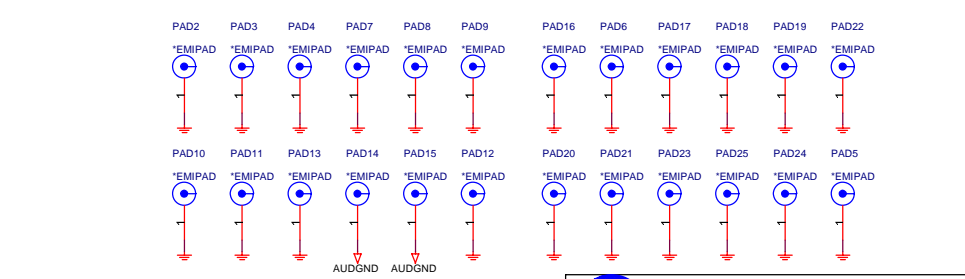
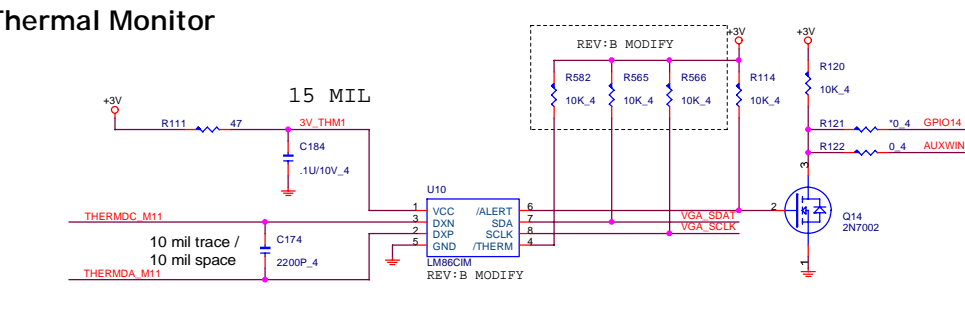
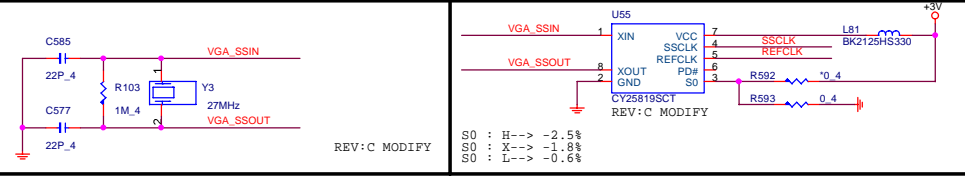
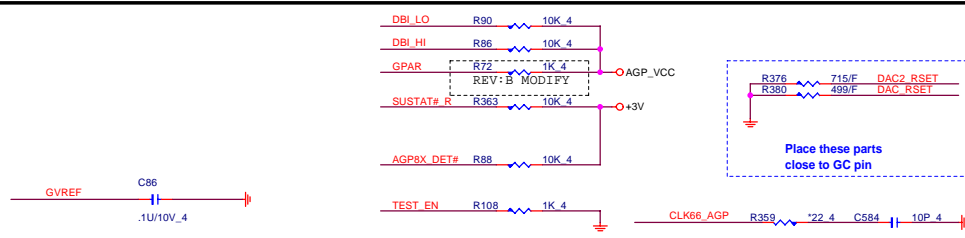
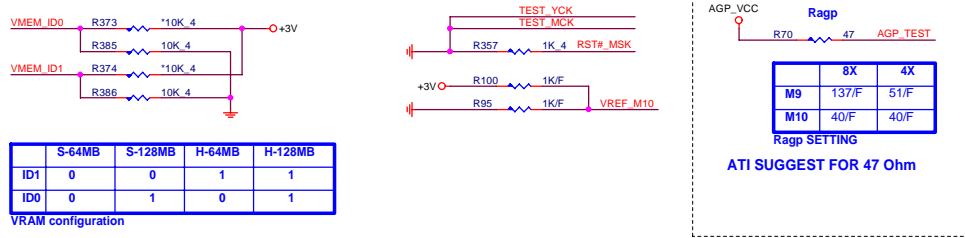
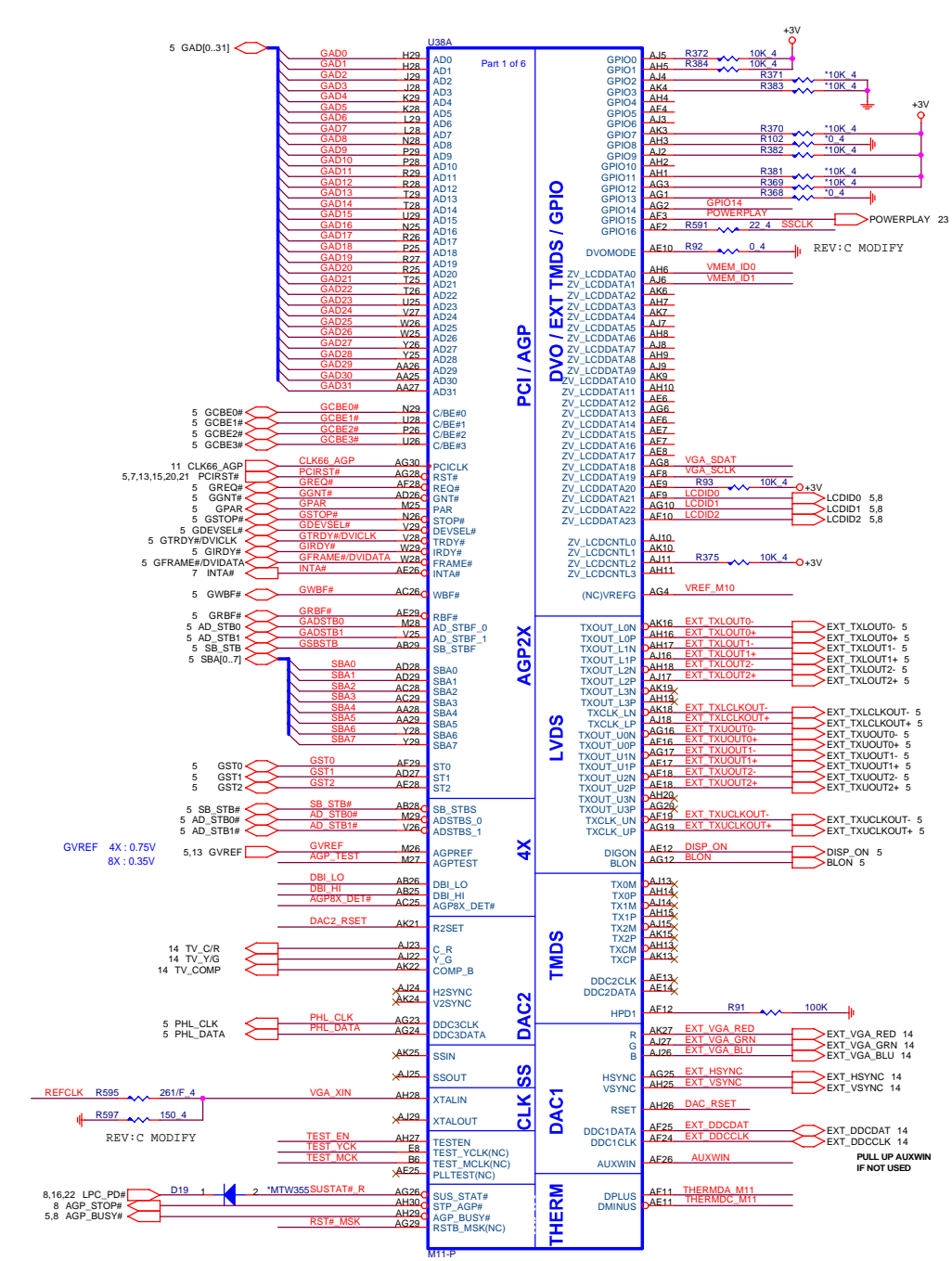

**PROJECT : ZL1**  
**Quanta Computer Inc.**

Size: Document Number: M11 (AGP, DISPLAY) Rev: C3A  
 Date: Friday, June 04, 2004 Sheet: 24 of 35



# VGA(MEMORY I/F)

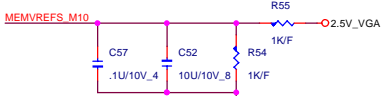
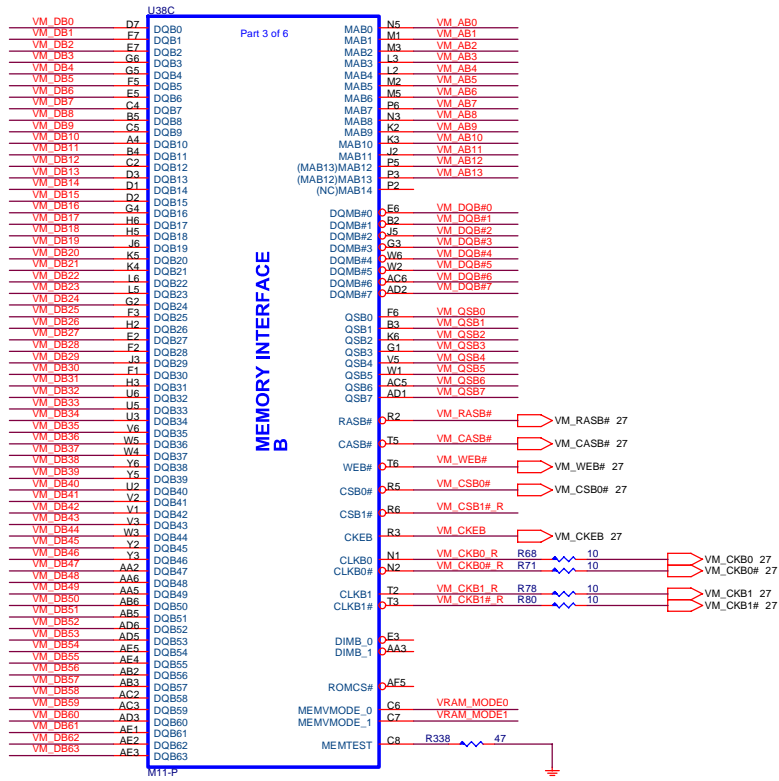
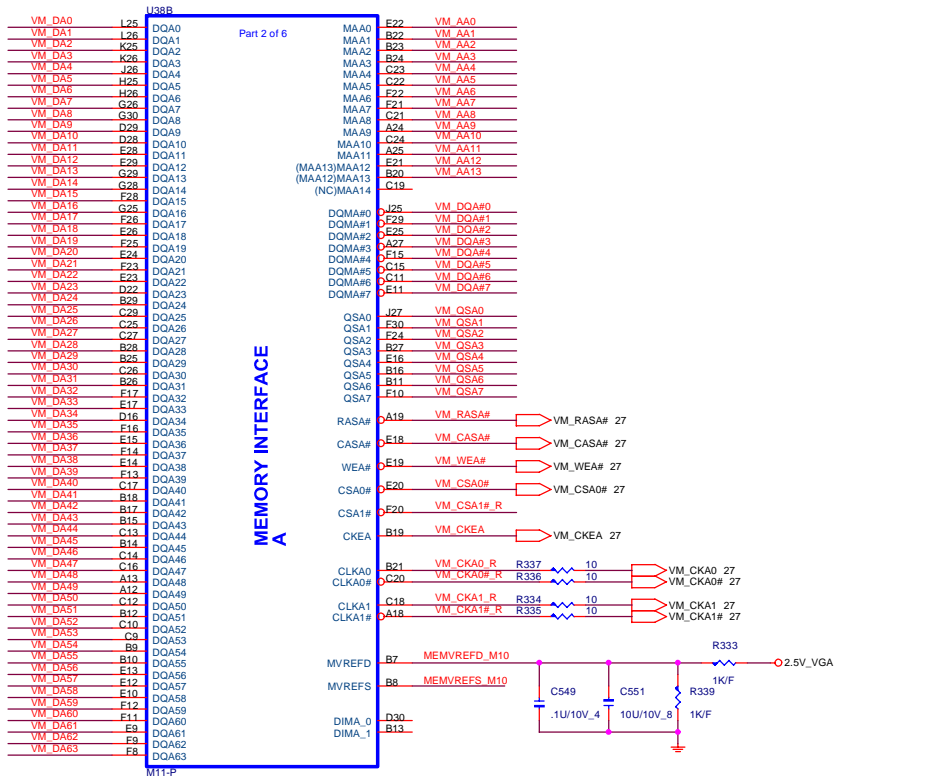
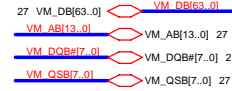
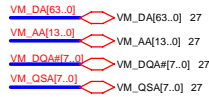

Mount these parts when use hynix 256Mb(8Mx32) VRAM chip

	VRAM_MODE1	VRAM_MODE0
2.5V	0	1
1.8V	1	0
2.8V	1	1

VRAM type setting

**PROJECT : ZL1**  
**Quanta Computer Inc.**

Size	Document Number	Rev
	<b>M11 ( MEMORY I/F )</b>	A1A
Date:	Fri, June 04, 2004	Sheet 25 of 35

# VGA(POWER)

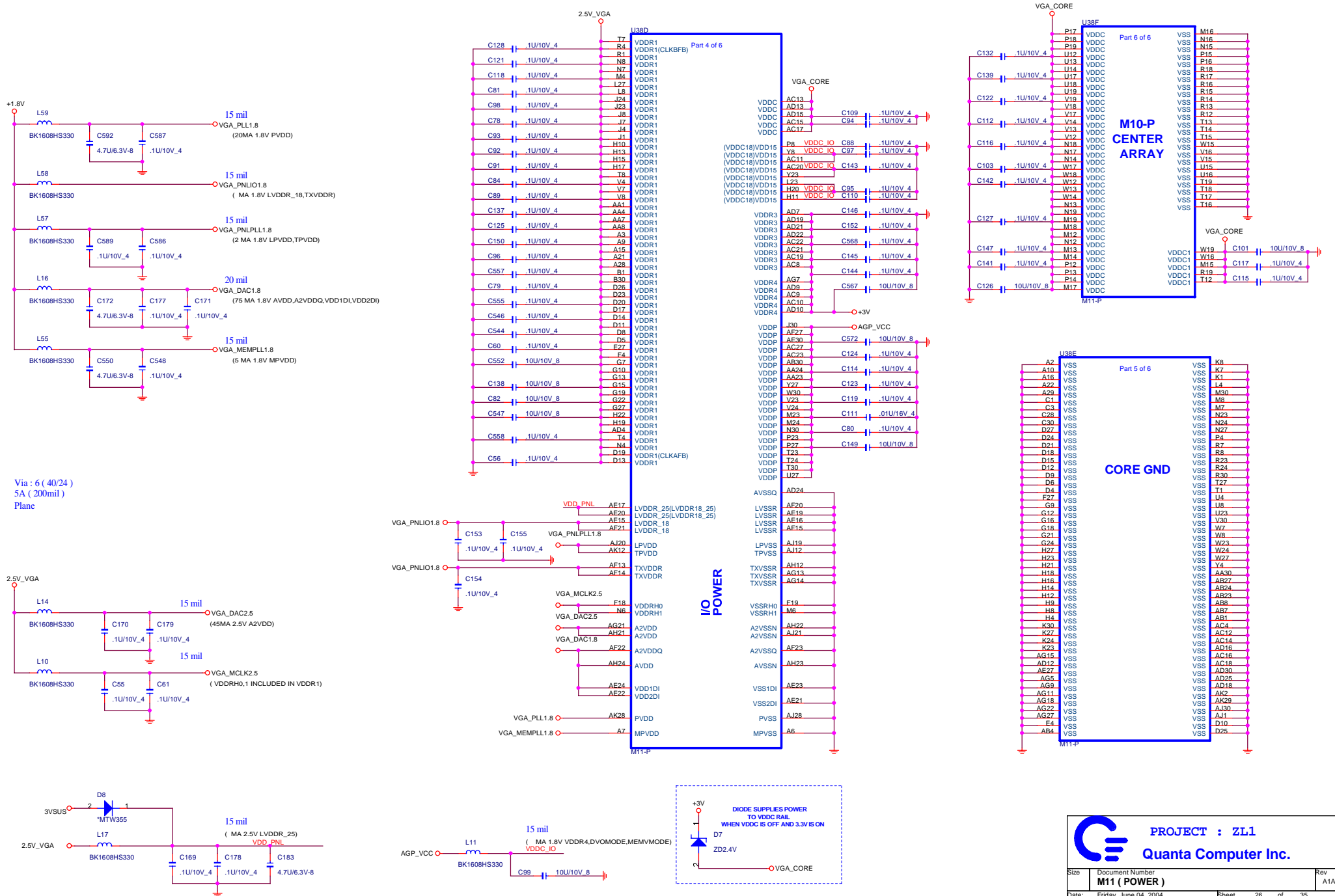



**PROJECT : ZL1**  
**Quanta Computer Inc.**

Size	Document Number	Rev
Date: Friday, June 04, 2004	<b>M11 (POWER)</b>	A1A
Sheet	26	of 35

VGA(VRAM)

VRAM Channel A

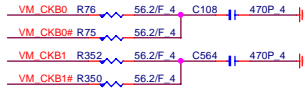
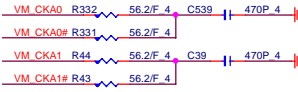

VRAM Channel B

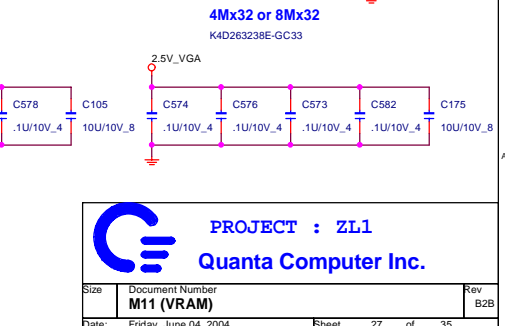
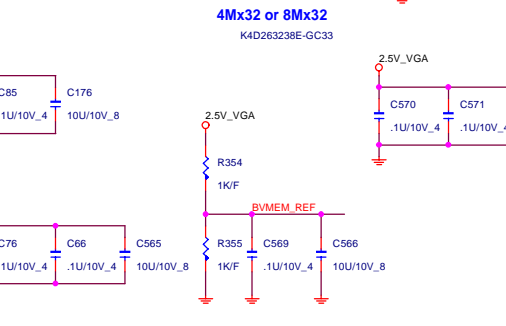
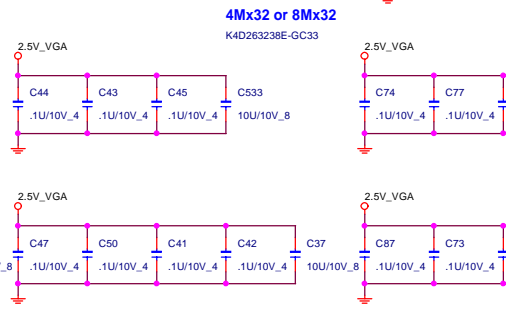
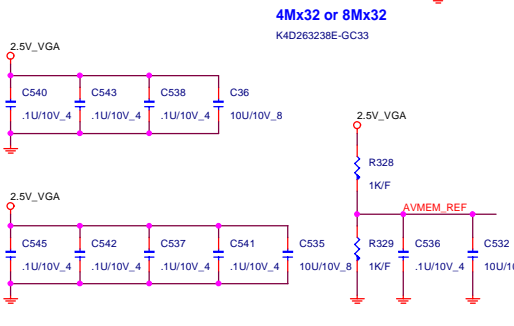
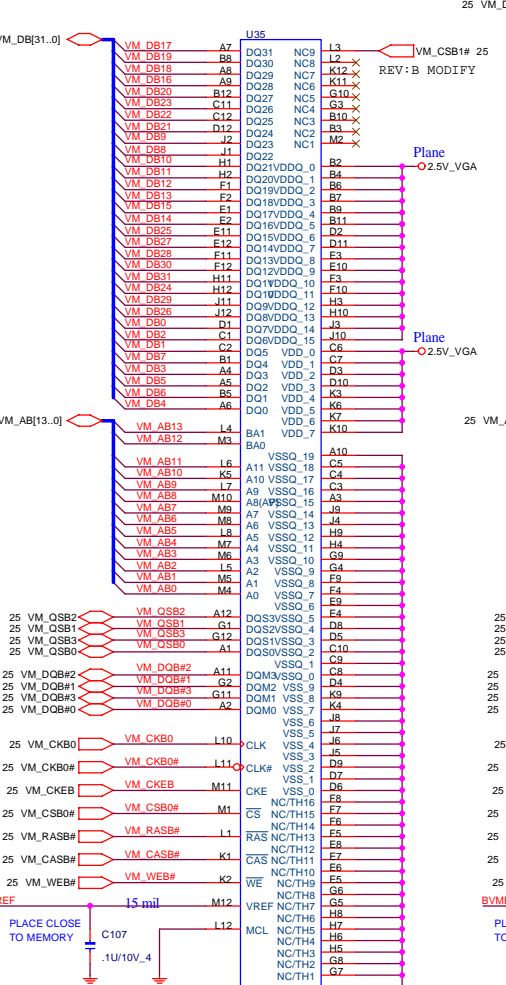
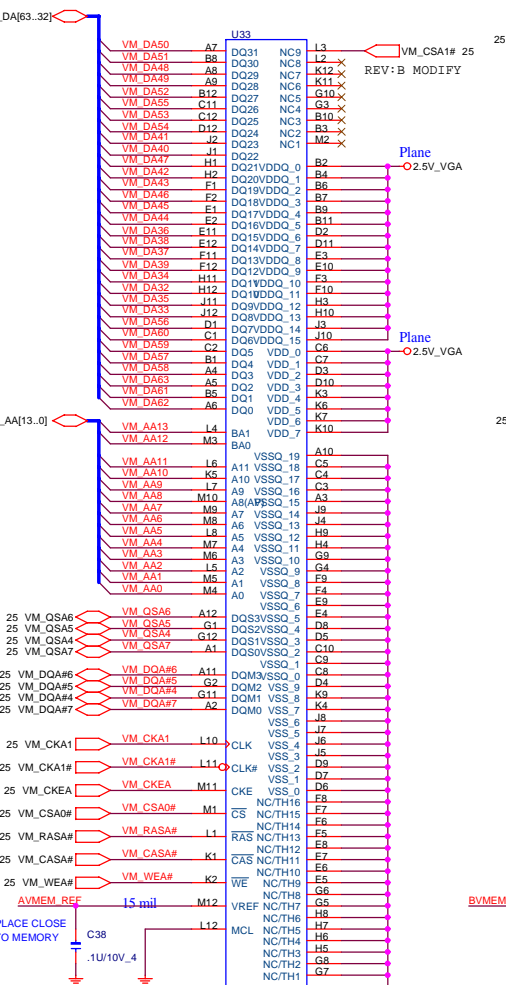
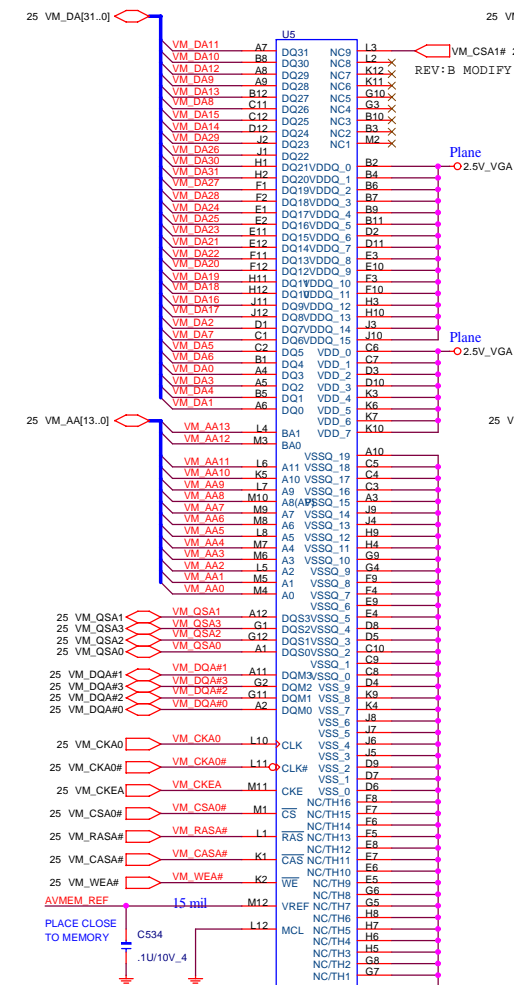

PROJECT : ZL1  
Quanta Computer Inc.  
Size Document Number M11 (VRAM) Rev 82B  
Date: Friday, June 04, 2004 Sheet 27 of 35

**INT K/B**

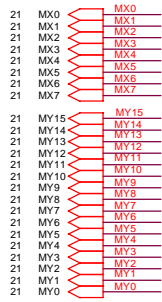

**REV:C MODIFY**

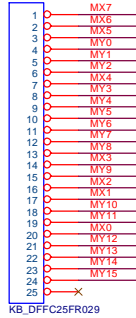

**3V\_ALWAYS**

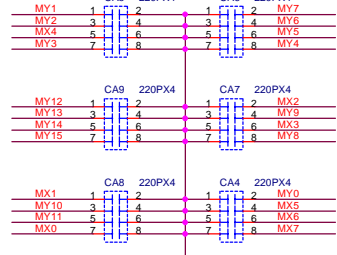
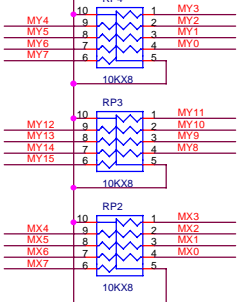

**FAN CONTROL**

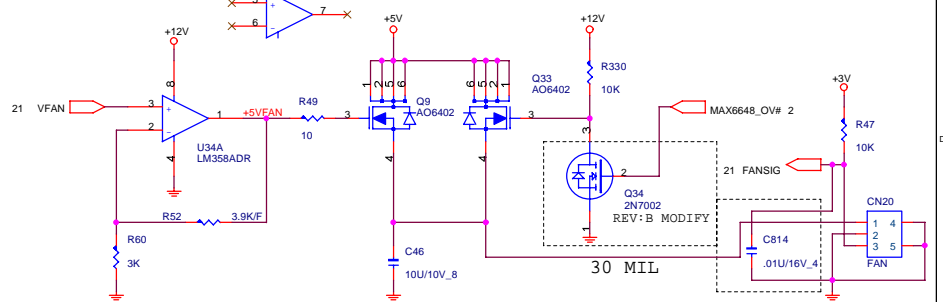

**TOUCH PAD**

**20 MIL**

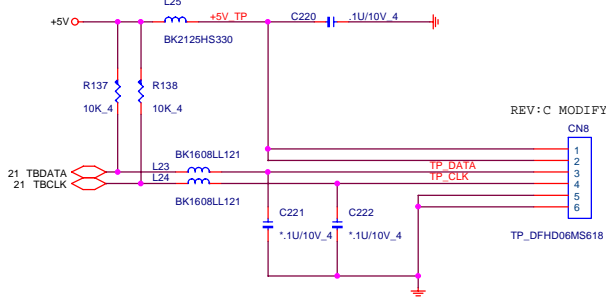

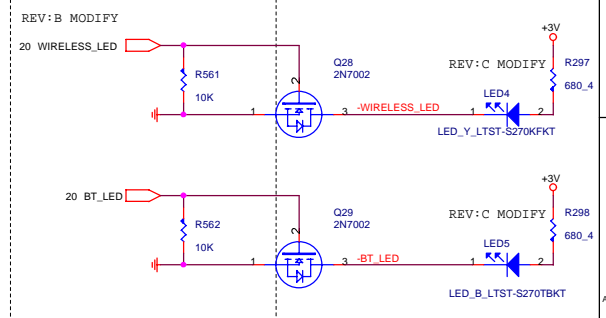
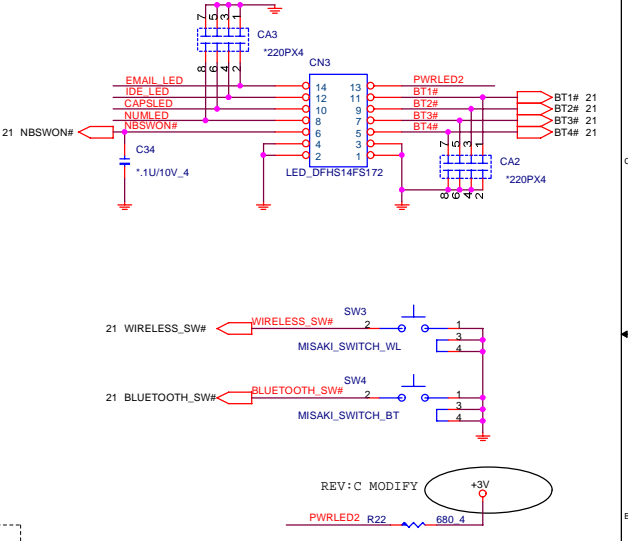
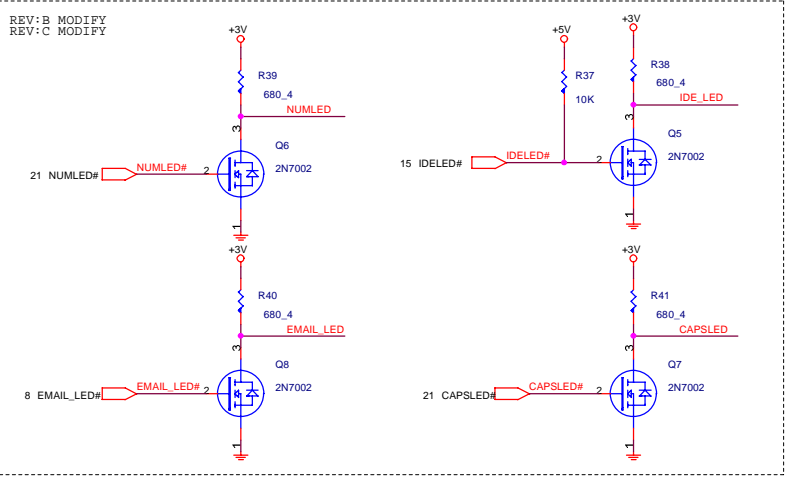
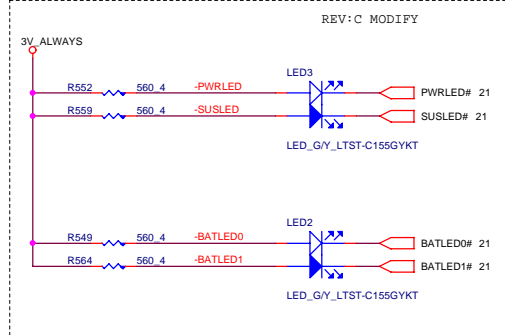
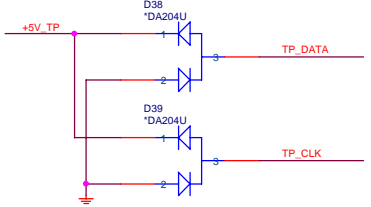

**REV:C MODIFY**

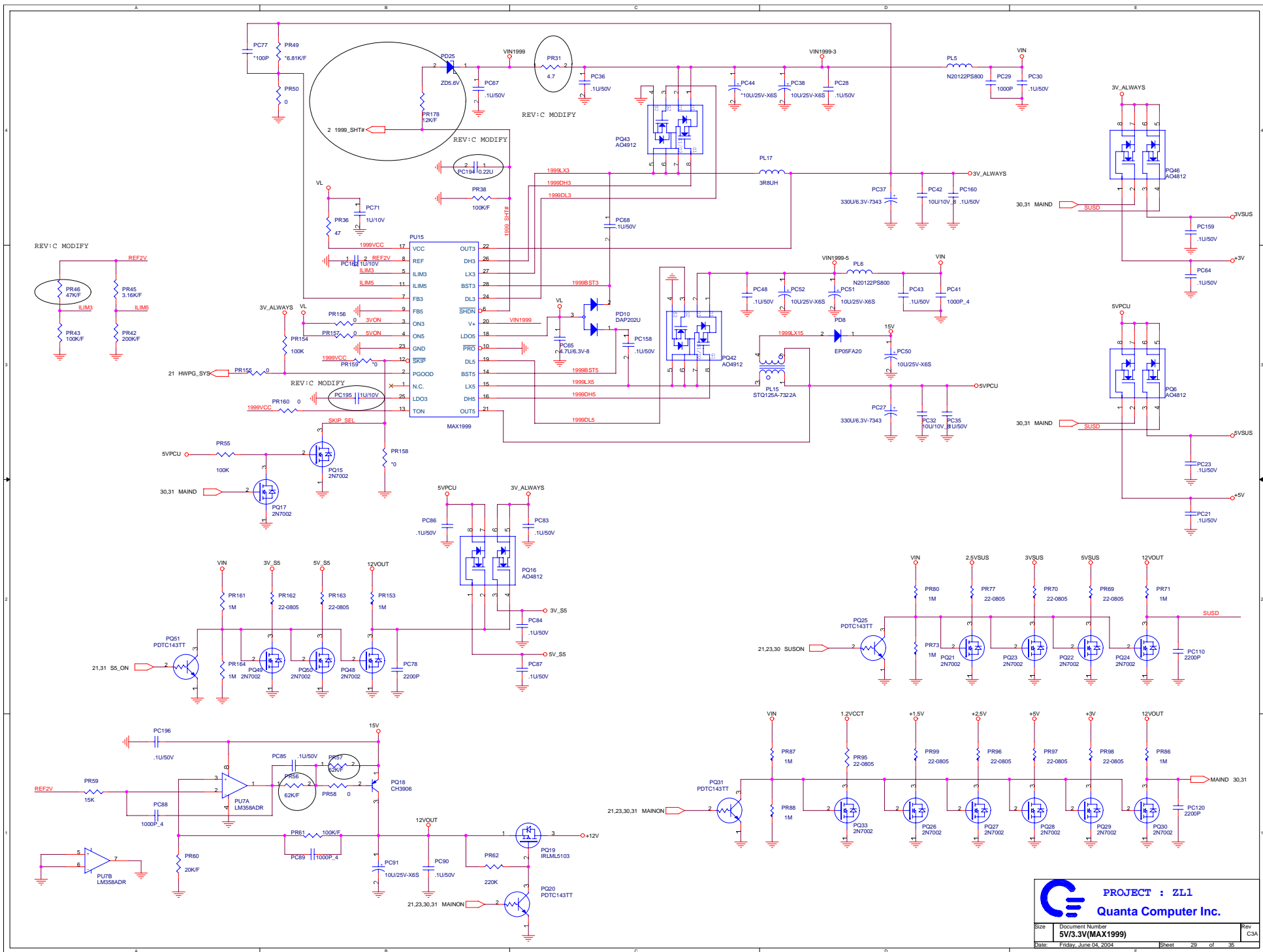

**PROJECT : ZL1**  
**Quanta Computer Inc.**

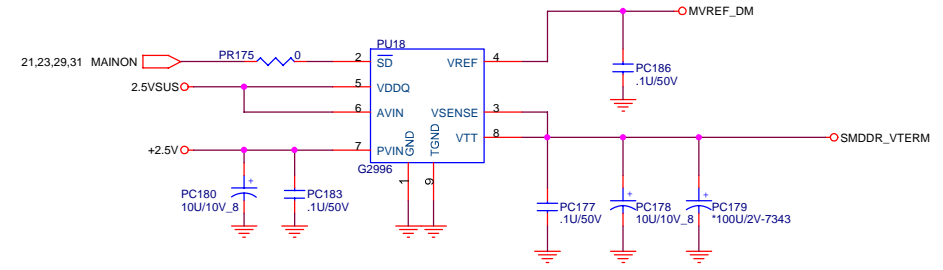
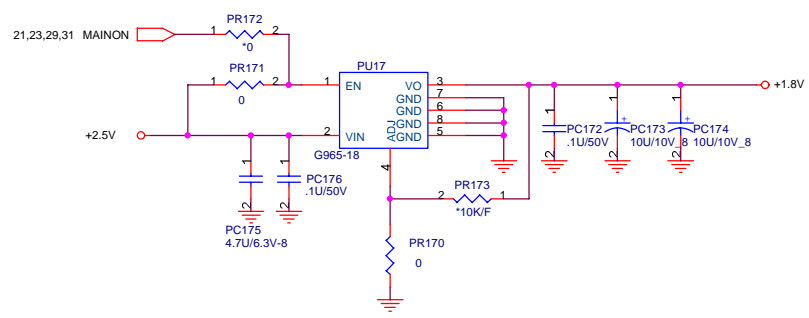
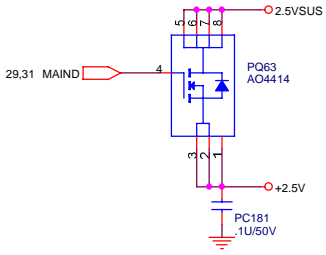
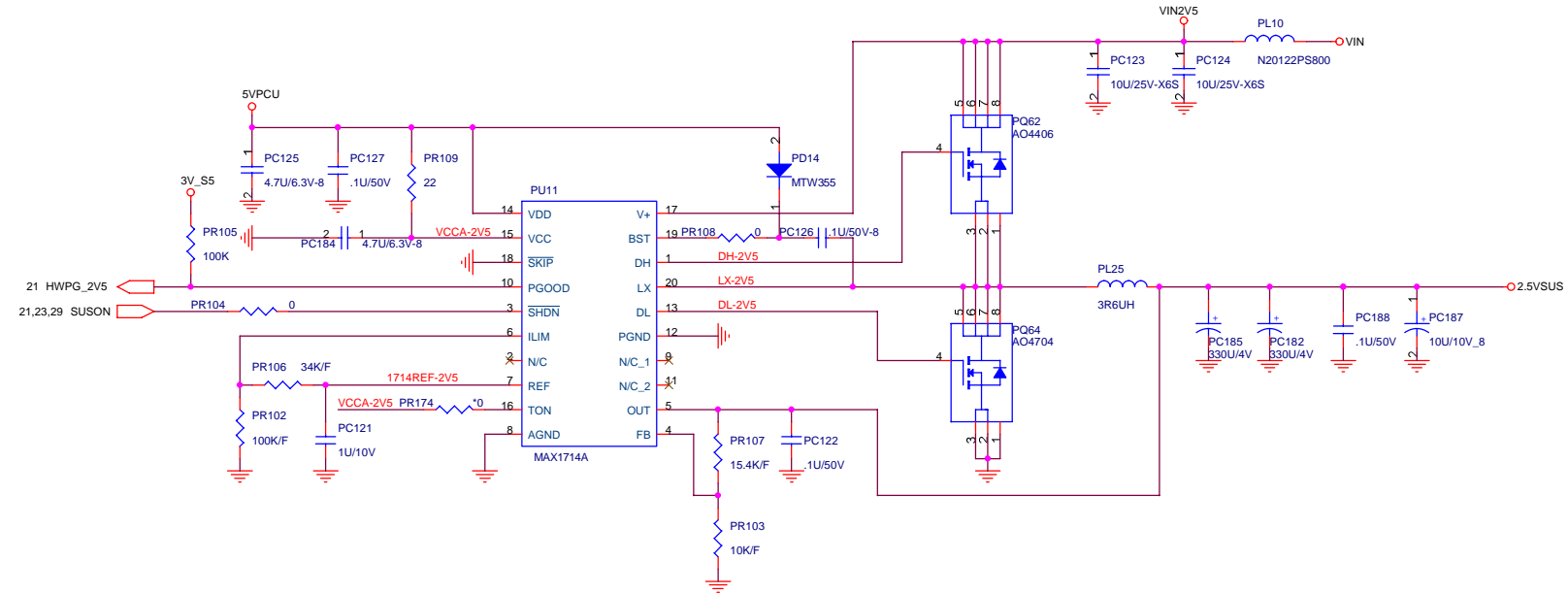



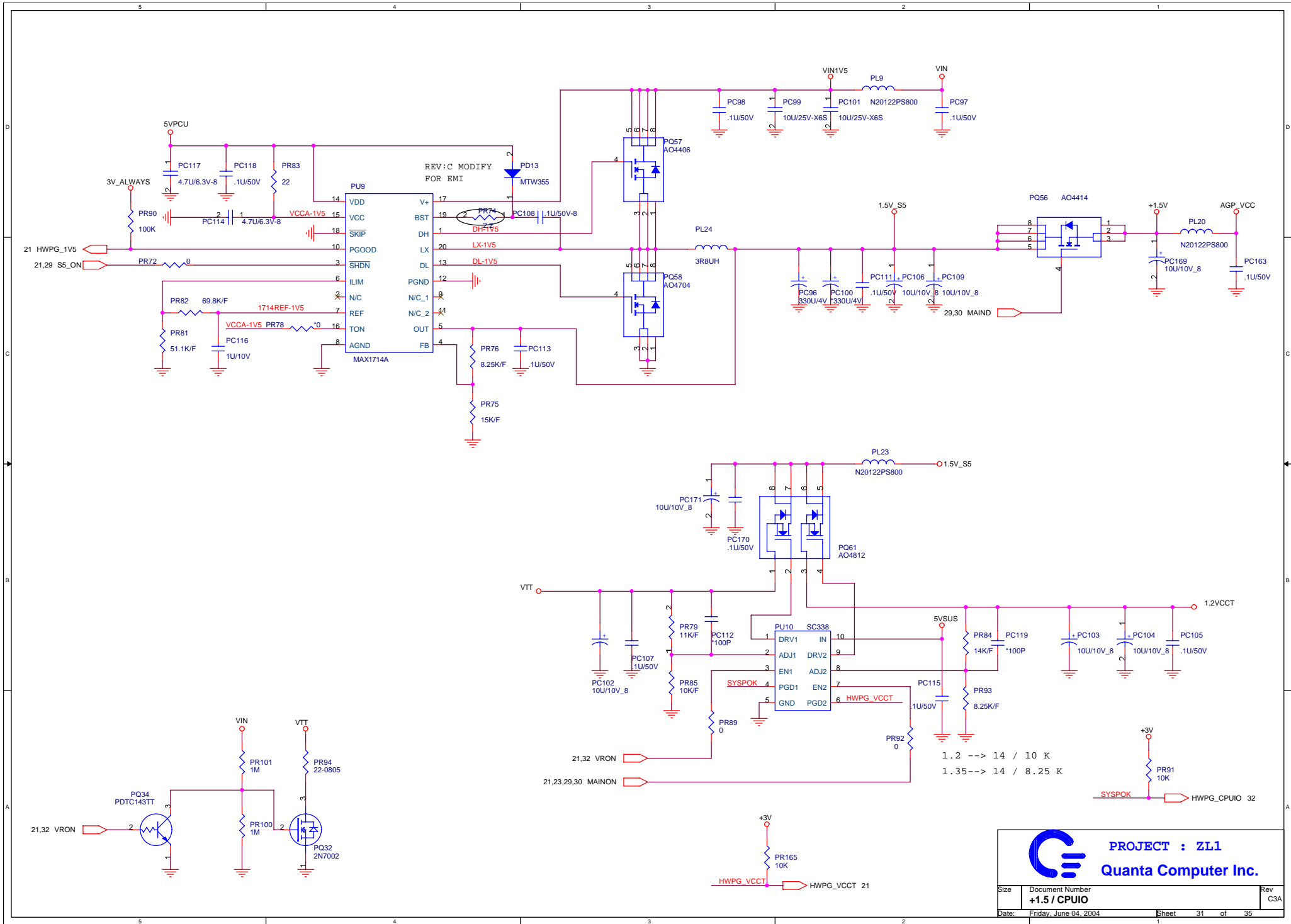

**PROJECT : ZL1**  
**Quanta Computer Inc.**

Size	Document Number	Rev
Date	2.5VSUS / +1.25TERM	A1A
Date:	Friday, June 04, 2004	Sheet 30 of 35

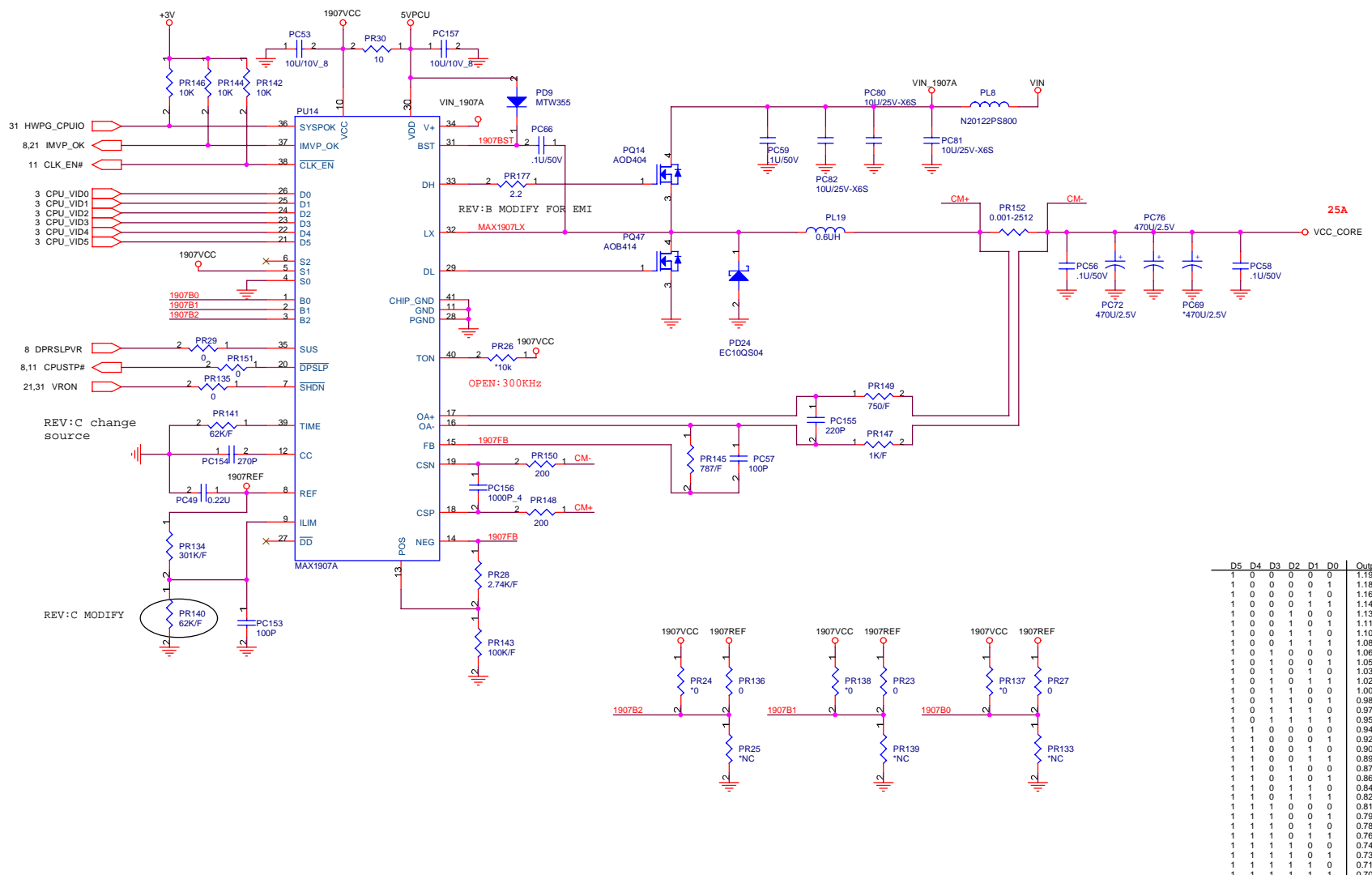

**PROJECT : ZL1**  
**Quanta Computer Inc.**

Size	Document Number	Rev
	<b>+1.5 / CPUIO</b>	C3A
Date:	Friday, June 04, 2004	Sheet 31 of 35



D5	D4	D3	D2	D1	D0	Output	D5	D4	D3	D2	D1	D0	Output
1	0	0	0	0	0	1.196V	0	0	0	0	0	0	1.708V
1	0	0	0	0	1	1.180V	0	0	0	0	0	1	1.692V
1	0	0	0	1	0	1.164V	0	0	0	0	1	0	1.676V
1	0	0	1	1	1	1.148V	0	0	0	1	0	1	1.660V
1	0	1	0	0	0	1.132V	0	0	1	0	0	0	1.644V
1	0	1	0	1	1	1.116V	0	0	1	0	1	0	1.628V
1	0	1	1	0	0	1.100V	0	0	1	1	0	0	1.612V
1	0	1	1	1	1	1.084V	0	0	1	1	1	1	1.596V
1	1	0	0	0	0	1.068V	0	1	0	0	0	0	1.580V
1	1	0	0	0	1	1.052V	0	1	0	0	1	0	1.564V
1	1	0	0	1	0	1.036V	0	1	0	1	0	1	1.548V
1	1	0	1	1	1	1.020V	0	1	1	0	1	1	1.532V
1	1	1	0	0	0	1.004V	0	1	1	1	0	0	1.516V
1	1	1	0	1	1	0.988V	0	1	1	1	1	1	1.500V
1	1	1	1	1	0	0.972V	0	1	1	1	1	0	1.484V
1	1	1	1	1	1	0.956V	0	1	1	1	1	1	1.468V
1	1	0	0	0	0	0.940V	0	1	0	0	0	0	1.452V
1	1	0	0	0	1	0.924V	0	1	0	0	1	0	1.436V
1	1	0	0	1	0	0.908V	0	1	0	1	0	1	1.420V
1	1	0	1	1	1	0.892V	0	1	1	0	1	1	1.404V
1	1	1	0	0	0	0.876V	0	1	1	1	0	0	1.388V
1	1	1	0	1	1	0.860V	0	1	1	1	1	1	1.372V
1	1	1	1	0	0	0.844V	0	1	1	1	1	0	1.356V
1	1	1	1	1	1	0.828V	0	1	1	1	1	1	1.340V
1	1	1	0	0	0	0.812V	0	1	1	0	0	0	1.324V
1	1	1	0	0	1	0.796V	0	1	1	0	1	0	1.308V
1	1	1	0	1	0	0.780V	0	1	1	0	1	0	1.292V
1	1	1	1	1	1	0.764V	0	1	1	1	1	1	1.276V
1	1	1	1	0	0	0.748V	0	1	1	1	0	0	1.260V
1	1	1	1	1	0	0.732V	0	1	1	1	1	0	1.244V
1	1	1	1	1	1	0.716V	0	1	1	1	1	1	1.228V
1	1	1	1	1	1	0.700V	0	1	1	1	1	1	1.212V

SUSPEND MODE (SUS=HIGH)

S2	S1	S0	Output
✓ OPEN	VCC	GND	0.748V

VCC\_BOOT

B2	B1	B0	Output
✓ GND	GND	GND	1.708V
REF	REF	REF	1.372V
OPEN	OPEN	OPEN	1.036V
VCC	VCC	VCC	0.700V
REF	VCC	VCC	1.212V



**PROJECT : ZL1**  
**Quanta Computer Inc.**

Size	Document Number <b>CPU CORE (MAX1907)</b>	Rev C3A
Date:	Friday, June 04, 2004	Sheet 32 of 35



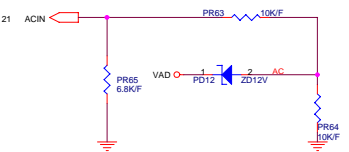
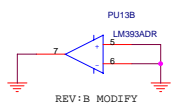
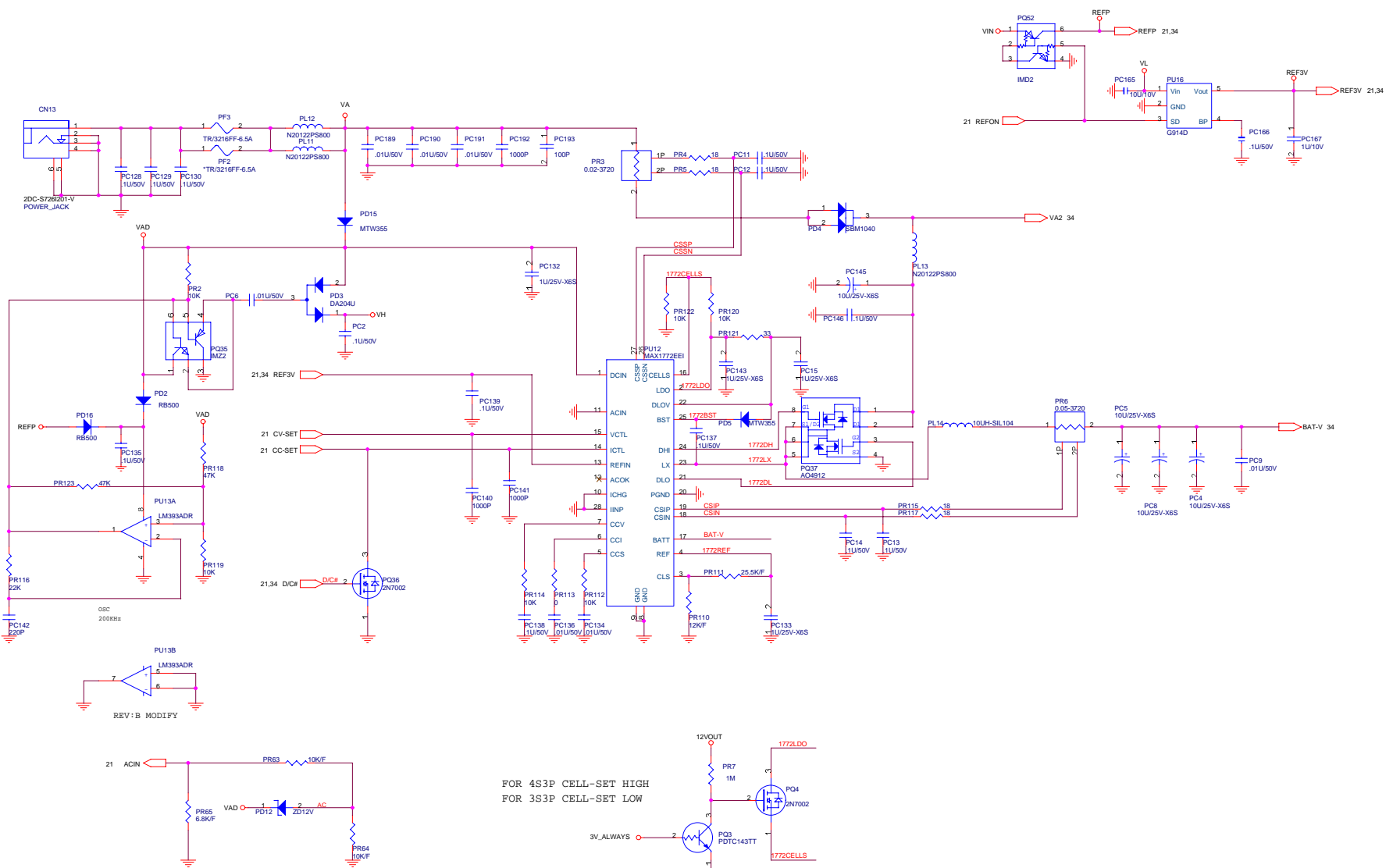

FOR 4S3P CELL-SET HIGH  
FOR 3S3P CELL-SET LOW

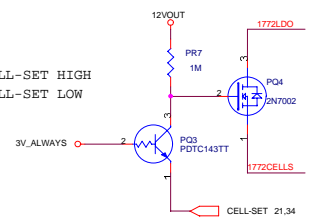

1ST\_BATT\_CONN

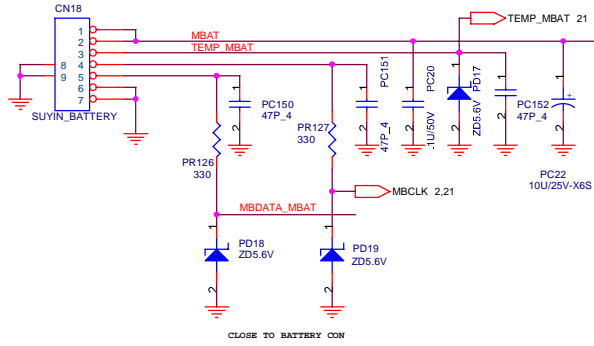

CLOSE TO BATTERY CON

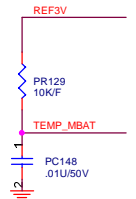

2ND\_BATT\_CONN

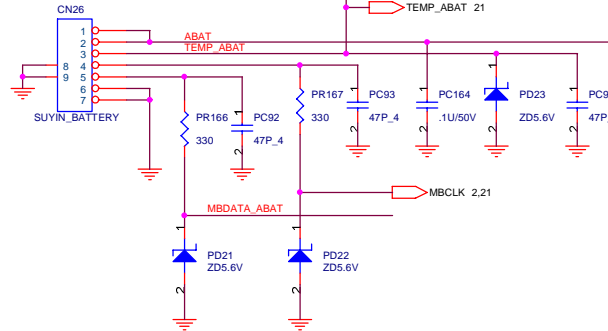

CLOSE TO BATTERY CON

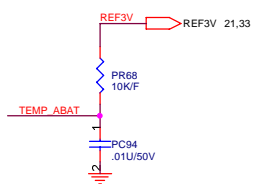

1ST\_BATT  
MBDATA\_MBAT  
MBDATA\_ABAT  
2ND\_BATT

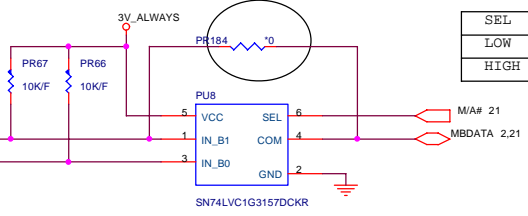

SEL	FUNCTION
LOW	IN_B0
HIGH	IN_B1

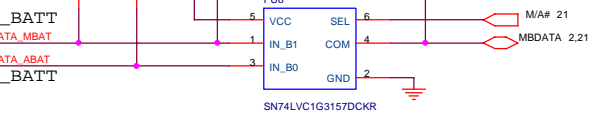

SN74LVC1G3157DCKR

SEL FUNCTION

**PROJECT : ZL1**  
**Quanta Computer Inc.**

Size	Document Number	Rev
	<b>BATTERY SELECT</b>	C3A
Date:	Friday, June 04, 2004	Sheet 34 of 35

MODEL:	REV:	CHANGE LIST:	PAGE	FROM	TO
ZL1 MotherBoard	B2B	PAGE2 . 1.UN-STUFF R392 FOR THERMTRIP 2. STUFF NUTS PAGE5 . 1.ADD +3V FOR LCD EDID 2.MODIFY C528 VALUE PAGE8 . 1.STUFF R204 FOR THERMTRIPS PAGE12. 1.ADD 10/100 CO LAYOUT CIRCUIT PAGE13. 1.ADD PR_INSERT# FOR SYSTEM CIRCUIT 2.MODIFY LAN SWITCH POWER PAGE14. 1.ADD PR_INSERT# FOR SYSTEM CIRCUIT PAGE15. 1.ADD RBAYIDL PULL DOWN RESISTOR PAGE18. 1.MODIFY FOR AUDIO QUALITY PAGE19. 1.MODIFY FOR AUDIO QUALITY PAGE20. 1.ADD EMI SOLUTION PAGE22. 1.MODIFY PR_INSERT# PULL HIGH VOLTAGE PAGE23. 1.STUFF PC45 FOR VGA CORE 2. MODIFY 2.5V VGA POWER PAGE24. 1.MODIFY GPAR PULL HIGH RESISTOR 2. ADD PULL HIGH FOR I2C BUS PAGE27. 1.MODIFY CS PIN FOR 128MB VRAM PAGE28. 1.MODIFY LED CIRCUIT 2. MODIFY Q34 TO 2N7002 PAGE29. 1.MODIFY MAX6648 OV# CIRCUIT PAGE32. 1.MODIFY CPU CORE VOLTAGE LEVEL PAGE33. 1.MODIFY CHARGER CIRCUIT PAGE34. 1.MODIFY CHARGER CIRCUIT	1	A1A	
			2	B2B	C3A
			3	A1A	
			4	A1A	
			5	B2B	
			6	A1A	
			7	A1A	
			8	B2B	
			9	A1A	
			10	A1A	
	C3A	PAGE02. 1.MODIFY MAX6648_AL# TO HIGH ACTIVE PAGE11. 1.MODIFY FOR SIGNAL QUALITY PAGE12. 1.MODIFY LAN LED 2. MODIFY LAN TRACE PULL HIGH PAGE13. 1.MODIFY LAN LED 2. MODIFY DVO_AVDD PAGE14. 1.MODIFY RGB BEAD VALUE PAGE16. 1.REMOVE COMMON MODE CHOKE PAGE17. 1.MODIFY 3 IN 1 CARD READER FOOTPRINT PAGE18. 1.MODIFY LINE IN SIGNAL PAGE19. 1.MODIFY LINE IN SIGNAL PAGE20. 1.MODIFY USB COMMON MODE CHOKE 2. MODIFY MINI-PCI 3V_S5 TO 3VSUS PAGE21. 1.MODIFY 97551 PIN 21 PAGE22. 1.MODIFY U30 PIN23 TO +5V PAGE23. 1.MODIFY FOR EMI SOLUTION PAGE24. 1.ADD EMI SOLUTION PAGE28. 1.MODIFY PWRLED2 TO +3V 2. ADD TP ESD PROTECT 3. MODIFY LED CIRCUIT PAGE29. 1.MODIFY FOR POWER SUHTDOWN ISSUE PAGE31. 1.MODIFY FOR EMI SOLUTION PAGE32. 1.CHANGE SOURCE PAGE34. 1.MODIFY CHARGER CIRCUIT FOR COST DOWN	11	A1A	C3A
			12	B2B	C3A
			13	B2B	C3A
			14	B2B	C3A
			15	B2B	
			16	A1A	C3A
			17	A1A	C3A
			18	B2B	C3A
			19	B2B	C3A
			20	B2B	C3A
			21	A1A	C3A
			22	B2B	C3A
			23	B2B	C3A
			24	B2B	C3A
			25	A1A	
			26	A1A	
			27	B2B	
			28	B2B	C3A
			29	B2B	C3A
			30	A1A	
			31	A1A	C3A
			32	B2B	C3A
			33	B2B	
			34	B2B	C3A
			35	B2B	C3A
 <b>PROJECT : ZL1</b> <b>Quanta Computer Inc.</b>			<b>COVER SHEET 1 OF 1</b>		
Size	Document Number	Rev			
	<b>CHANGE LIST</b>	C3A			
Date:	Friday, June 04, 2004	Sheet	35	of	35
PROJECT : ZL1		APPROVE BY: JIM HSU	DRAWING BY:JACKY CHENG	REV	C3A
MB ASSY'S P/N : 31ZLLMB0004		PROJECT LEADER: JIM HSU	DOCUMENT NO: 204	DATE	:2004/06/01