

DESCRIPTION

Demonstration circuit 2091A is optimized for evaluation of the [LTC®5599](#) low power direct quadrature modulator. The balanced I and Q baseband input ports can be either AC- or DC-coupled to a source with a common mode voltage level of about 1.4V. Fixed LC networks on the LO and RF ports cover a continuous 90MHz to 1300MHz range. The SPI interface controls the supply current, modulator

gain, and allows optimization of the LO carrier feedthrough and side-band suppression.

Design files for this circuit board are available at <http://www.linear.com/demo/DC2091A>

LT, LT, LTC, LTM, Linear Technology and the Linear logo are registered trademarks and QuikEval is a trademark of Linear Technology Corporation. All other trademarks are the property of their respective owners.

MEASUREMENT SETUP

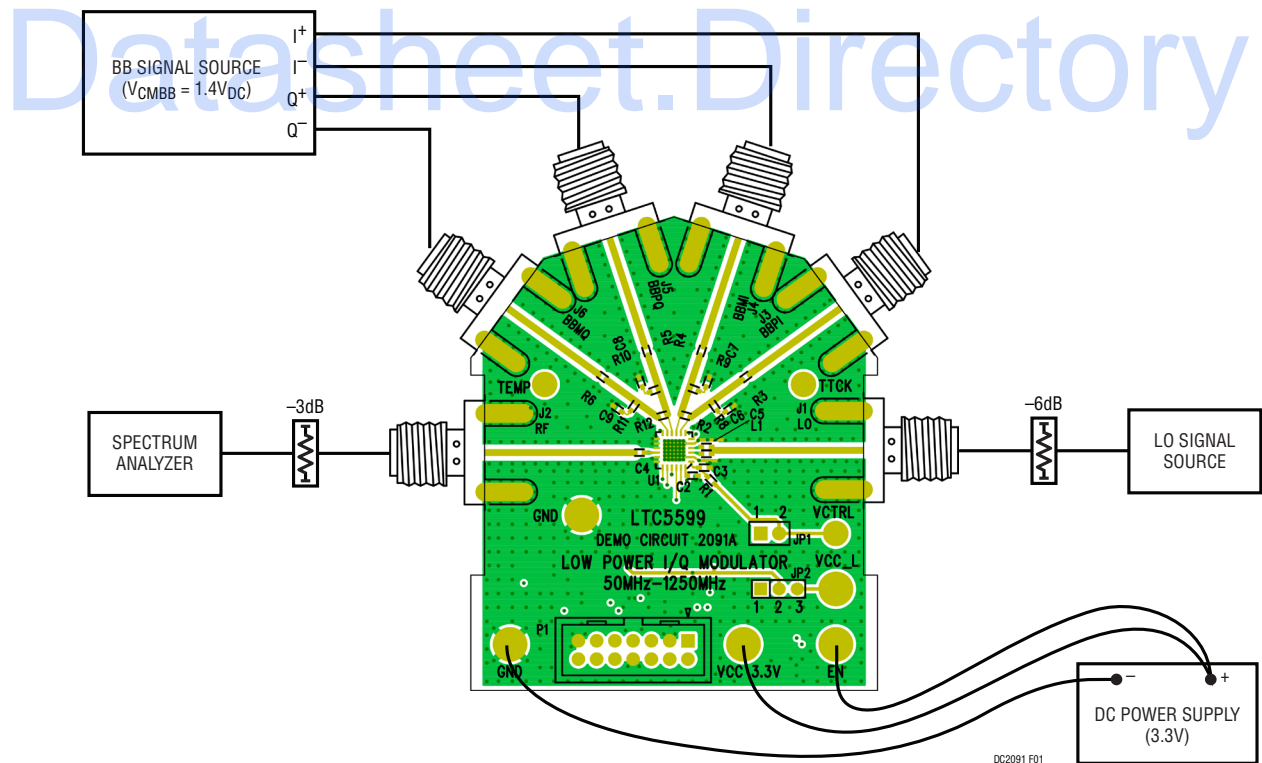

Figure 1. Test Setup for RF Performance Measurements

ABSOLUTE MAXIMUM INPUT RATINGS

Supply Voltage	3.8V
Common Mode Level of BBPI, BBMI, and BBPQ, BBMQ	2V
LOL, LOC DC Voltage	$\pm 0.1V$
LOL, LOC Input Power	20dBm
Voltage on Any Pin.....	$-0.3V$ to $V_{CC} + 0.3V$
T_{JMAX}	150°C

Case Operating Temperature Range.....	$-40^{\circ}C$ to $105^{\circ}C$
Storage Temperature Range	$-65^{\circ}C$ to $150^{\circ}C$

CAUTION: THIS PART IS SENSITIVE TO ELECTRO-STATIC DISCHARGE (ESD). OBSERVE PROPER ESD PRECAUTIONS WHEN HANDLING THE LTC5599.

NOTES ON TEST EQUIPMENT AND SETUP

- Use high performance signal generators with fully configurable differential I and Q outputs, such as the Rohde & Schwarz SMJ100A vector signal generator or equivalent.
- Use narrow resolution bandwidth (RBW) and engage video averaging on the spectrum analyzer to lower the displayed average noise level (DANL) in order to improve sensitivity and to increase dynamic range. The trade-off is increased sweep time.
- Spectrum analyzers can produce significant internal distortion products if they are overdriven. Generally, spectrum analyzers are designed to operate at their best with about $-30dBm$ to $-40dBm$ at their input filter or preselector. Sufficient spectrum analyzer input attenuation should be used to avoid saturating the instrument, but too much attenuation reduces sensitivity and dynamic range.
- Before taking measurements, the system performance should be evaluated to ensure that:
 - 1) clean input signals can be produced
 - 2) the spectrum analyzer's internal distortion is minimized
 - 3) the spectrum analyzer has enough dynamic range and sensitivity
 - 4) the system is accurately calibrated for power and frequency.
- Digital modulation often requires DC coupling and flat frequency response. For best EVM performance with complex modulation, the RC networks at the baseband I/Q inputs are not required.

QUICK START PROCEDURE

1. Remove the demonstration circuit from its protective packaging in an ESD-safe working area.
2. Turn off the DC power supply as well as the baseband and LO signal sources' outputs.
3. Connect all test equipment as show in Figure 1.
4. Make sure jumper JP1 is installed and the jumper JP2 is installed at the 1-2 position.
5. Slowly increase the supply voltage to 3.3V. Do not exceed 3.8V.
6. Turn on the baseband signal source. Set the baseband common mode bias to 1.4V.
7. Verify the total V_{CC} supply current is approximately 28mA. The demonstration circuit is now turned on and is ready for measurements.
8. Turn on the output of the LO source and apply a 492.8MHz, 0dBm CW Signal.
9. Set the baseband signal source to provide a 100kHz, 200mV_{P-P(DIFF)} baseband input signal. The I and Q channels should be 90° shifted and set for lower sideband selection.
10. Measure the modulator's RF output on the Spectrum Analyzer at 492.7MHz.

QUICK START PROCEDURE

11. Calculate the Voltage Conversion Gain:
Gain = $20 \cdot \log(V_{RF(OUT)}(50\Omega) / V_{IN(DIFF)}(I \text{ OR } Q))$
12. Measure the Output 1dB Compression Point by increasing the input signal level until the Voltage Conversion Gain degrades by 1dB.
13. Measure the Image Rejection at 492.9MHz.
14. Measure the LO Leakage at 492.8MHz.
15. Connect the DC590B to the DC2091A with the ribbon cable provided. Make sure jumper JP6 on the DC590B is set to 3.3V.
16. Run QuikEval® to start the GUI associated with the LTC5599.
17. The turn off procedure is the reverse of the turn on procedure. **Make sure V_{CC} is removed after V_{EN}.**

DEMO BOARD SCHEMATIC

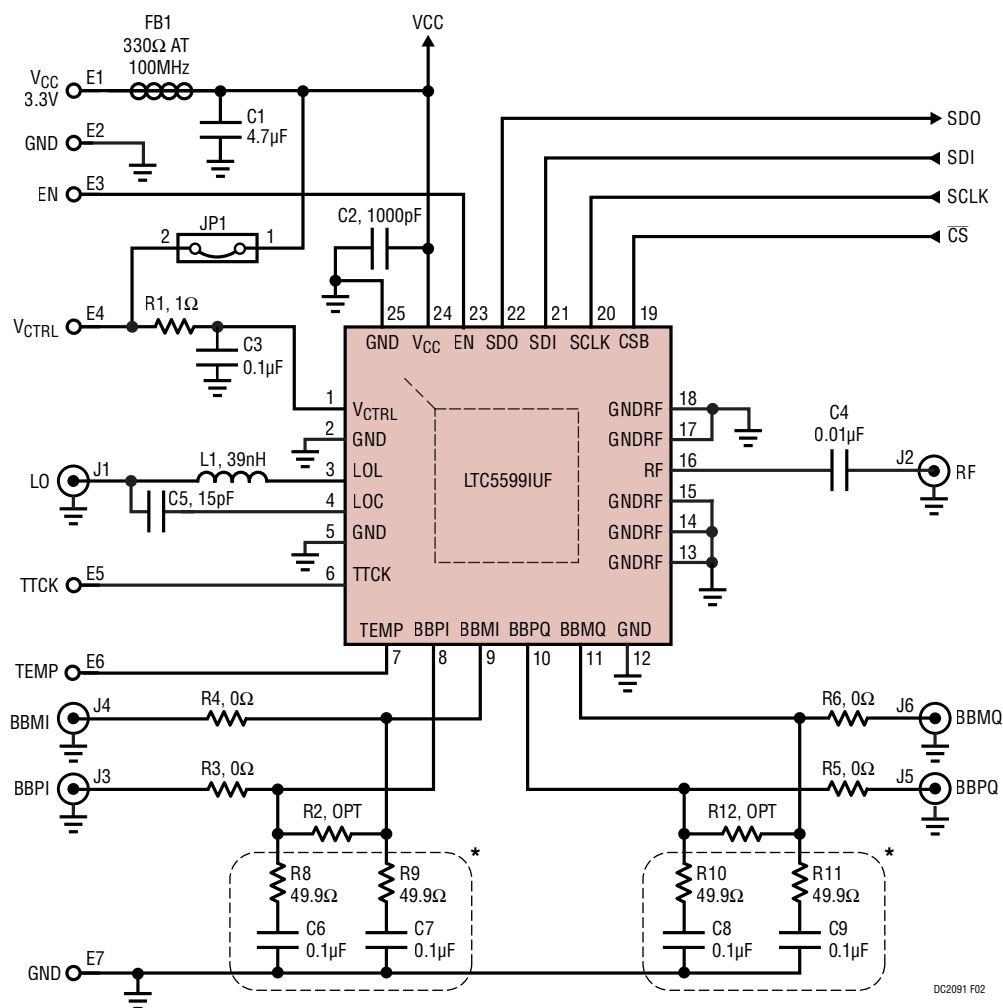

* REMOVE THE RC NETWORK FOR BEST EVM WITH COMPLEX DIGITAL MODULATION.

Figure 2. Low Power I/Q Modulator Schematic

DEMO BOARD SCHEMATIC

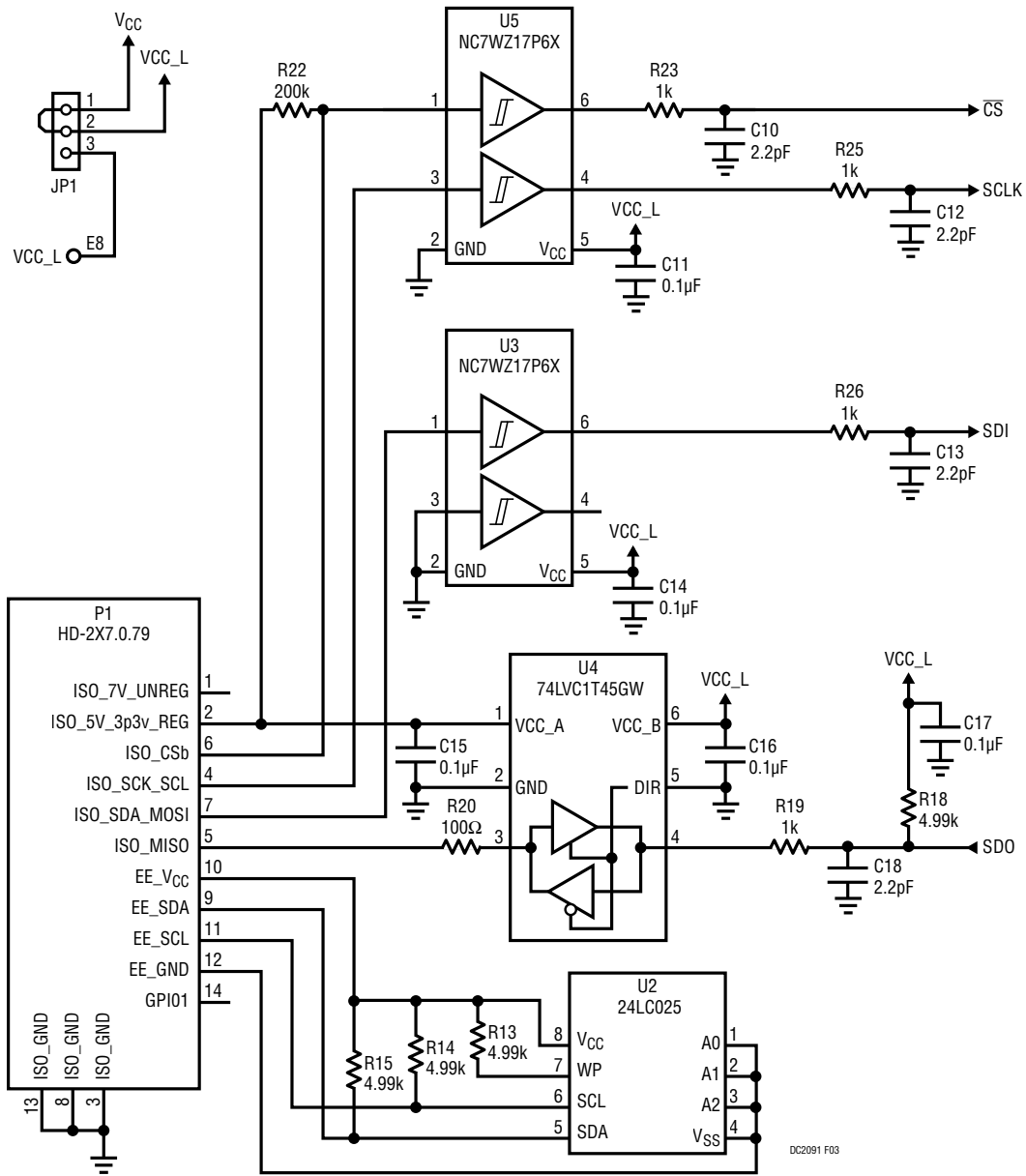

Figure 3. Demo Board SPI Interface

PARTS LIST

ITEM	QTY	REFERENCE	PART DESCRIPTION	MANUFACTURER/PART NUMBER
Required Circuit Components				
1	1	C1	CAP., X5R, 4.7µF, 10%, 16V, 0603	MURATA, GRM188R61C475KAAJD
2	1	C2	CAP., COG, 1000pF, 5%, 50V, 0402	MURATA, GRM1555C1H102JA01D
3	10	C3, C6–C9, C11, C14–C17	CAP., X7R, 0.1µF, 10%, 16V, 0402	MURATA, GRM155R71C104KA88D
4	1	C4	CAP., X7R, 0.01µF, 10%, 16V, 0402	MURATA, GRM155R71C103KA01D
5	1	C5	CAP., COG, 15pF, 5%, 50V, 0402	MURATA, GRM1555C1H150JA01D
6	4	C10, C12, C13, C18	CAP., COG, 2.2pF, +/- .1pF, 25V, 0402	MURATA, GRM1555C1E2R2BZ01D
7	5	E1, E2, E3, E7, E8	TESTPOINT, TURRET, .094"	MILL-MAX, 2501-2-00-80-00-00-07-0
8	3	E4, E5, E6	TESTPOINT, TURRET, .063"	MILL-MAX, 2308-2-00-80-00-00-07-0
9	1	FB1	FERRITE BEAD, 33Ω @100MHz	TDK, MPZ1608S331AT
10	1	JP1	HEADER, 2 PIN, 0.079 SINGLE ROW	SULLINS, NRPN021PAEN-RC
11	1	JP2	HEADER, 3 PIN, 0.079 SINGLE ROW	SULLINS, NRPN031PAEN-RC
12	2	XJP4, XJP5	SHUNT, 2mm Ctrs.	SAMTEC, 2SN-BK-G
13	6	J1–J6	CONN., SMA, 50Ω, EDGE-LANCH	E.F.JOHNSON, 142-0701-851
14	1	L1	IND., 39nH, 0402HP	COILCRAFT, 0402HP-39NXJLU
15	1	P1	HEADER, 2X7PIN, 0.079CC	MOLEX, 87831-1420
16	1	R1	RES., CHIP, 1Ω, 1%, 0402	VISHAY, CRCW04021R00FNED
17	0	R2, R12	OPT, 0402	
18	4	R3, R4, R5, R6	RES., CHIP, 0Ω, 0402	VISHAY, CRCW04020000Z0ED
19	4	R8, R9, R10, R11	RES., CHIP, 49.9Ω, 1%, 0402	VISHAY, CRCW040249R9FKED
20	3	R13, R14, R15	RES., CHIP, 4.99K, 1%, 0402	VISHAY, CRCW04024K99FKED
21	5	R18, R19, R23, R25, R26	RES., CHIP, 1K, 1%, 0402	VISHAY, CRCW04021K00FKED
22	1	R20	RES., CHIP, 100Ω, 1%, 0402	VISHAY, CRCW0402100RFKED
23	1	R22	RES., CHIP, 200K, 1%, 0402	VISHAY, CRCW0402200KFKEA
24	1	U1	IC., LTC5599, QFN-24-4X4	LINEAR TECHNOLOGY, LTC5599IUF#PBF
25	1	U2	IC, EEPROM 2KBIT 400KHZ 8TSSOP	MICROCHIP TECH., 24LC025-I/ST
26	2	U3, U5	I.C., DUAL BUFFER SCHMT TRIG UHS SC706	FAIRCHILD SEMI., NC7WZ17P6X
27	1	U4	I.C., DUAL TRANSCEIVER 3ST 6TSSOP	NXP, 74LVC1T45GW,125
28	1		FAB, PRINTED CIRCUIT BOARD	DEMO CIRCUIT DC2091A

DEMO MANUAL DC2091A

DEMONSTRATION BOARD IMPORTANT NOTICE

Linear Technology Corporation (LTC) provides the enclosed product(s) under the following **AS IS** conditions:

This demonstration board (DEMO BOARD) kit being sold or provided by Linear Technology is intended for use for **ENGINEERING DEVELOPMENT OR EVALUATION PURPOSES ONLY** and is not provided by LTC for commercial use. As such, the DEMO BOARD herein may not be complete in terms of required design-, marketing-, and/or manufacturing-related protective considerations, including but not limited to product safety measures typically found in finished commercial goods. As a prototype, this product does not fall within the scope of the European Union directive on electromagnetic compatibility and therefore may or may not meet the technical requirements of the directive, or other regulations.

If this evaluation kit does not meet the specifications recited in the DEMO BOARD manual the kit may be returned within 30 days from the date of delivery for a full refund. **THE FOREGOING WARRANTY IS THE EXCLUSIVE WARRANTY MADE BY THE SELLER TO BUYER AND IS IN LIEU OF ALL OTHER WARRANTIES, EXPRESSED, IMPLIED, OR STATUTORY, INCLUDING ANY WARRANTY OF MERCHANTABILITY OR FITNESS FOR ANY PARTICULAR PURPOSE. EXCEPT TO THE EXTENT OF THIS INDEMNITY, NEITHER PARTY SHALL BE LIABLE TO THE OTHER FOR ANY INDIRECT, SPECIAL, INCIDENTAL, OR CONSEQUENTIAL DAMAGES.**

The user assumes all responsibility and liability for proper and safe handling of the goods. Further, the user releases LTC from all claims arising from the handling or use of the goods. Due to the open construction of the product, it is the user's responsibility to take any and all appropriate precautions with regard to electrostatic discharge. Also be aware that the products herein may not be regulatory compliant or agency certified (FCC, UL, CE, etc.).

No License is granted under any patent right or other intellectual property whatsoever. **LTC assumes no liability for applications assistance, customer product design, software performance, or infringement of patents or any other intellectual property rights of any kind.**

LTC currently services a variety of customers for products around the world, and therefore this transaction **is not exclusive**.

Please read the DEMO BOARD manual prior to handling the product. Persons handling this product must have electronics training and observe good laboratory practice standards. **Common sense is encouraged.**

This notice contains important safety information about temperatures and voltages. For further safety concerns, please contact a LTC application engineer.

Mailing Address:

Linear Technology
1630 McCarthy Blvd.
Milpitas, CA 95035

Copyright © 2004, Linear Technology Corporation