

## Hi-Rel 80 V, 1 A NPN transistor

Datasheet - production data

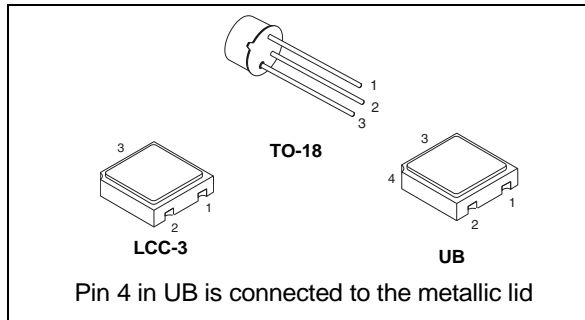

**Figure 1. Internal schematic diagram**

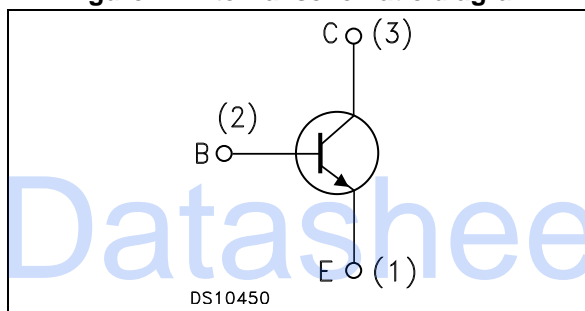

### Features

$V_{(BR)CEO}$	80 V
$I_C(max)$	1 A
HFE at 10 V - 150 mA	>100

- Hermetic packages
- ESCC and Jans qualified
- Up to 100 krad(Si) low dose rate

### Description

The 2N3700HR is a NPN transistor specifically designed for aerospace and Hi-Rel applications. It is available in the JAN qualification system (MIL-PRF19500) and in the ESCC qualification system (ESCC 5000). In case of discrepancies between this datasheet and the relevant agency specification, the latter takes precedence.

**Table 1. Device summary**

Device	Qualification system	Agency specification	Package	Radiation level	EPPL
JANSR2N3700UBx	JANSR	MIL-PRF-19500/391	UB	100 krad high and low dose rate	-
JANS2N3700UBx	JANS	MIL-PRF-19500/391	UB	-	-
2N3700RUBx	ESCC Flight	5201/004	UB	100 krad - low dose rate	Target
2N3700UBx	ESCC Flight	5201/004	UB	-	Target
SOC3700RHRx	ESCC Flight	5201/004	LCC-3	100 krad - low dose rate	Yes
SOC3700HRx	ESCC Flight	5201/004	LCC-3	-	Yes
2N3700RHRx	ESCC Flight	5201/004	TO-18	100 krad - low dose rate	-
2N3700HRx	ESCC Flight	5201/004	TO-18	-	-

# Contents

- 1      Electrical ratings ..... 3**
  
- 2      Electrical characteristics ..... 4**
  - 2.1    JANS electrical characteristics ..... 4
  - 2.2    ESCC electrical characteristics ..... 5
  - 2.3    Electrical characteristics (curves) ..... 6
  - 2.4    Test circuits ..... 7
  
- 3      Radiation hardness assurance ..... 9**
  
- 4      Package information ..... 12**
  - 4.1    UB package information ..... 13
  - 4.2    LCC-3 package information ..... 15
  - 4.3    TO-218 package information ..... 17
  
- 5      Order codes ..... 19**
  
- 6      Shipping details ..... 21**
  - 6.1    Date code ..... 21
  - 6.2    Documentation ..... 21
  
- 7      Revision history ..... 22**

# 1 Electrical ratings

**Table 2. Absolute maximum ratings**

Symbol	Parameter		Value	Unit
$V_{CBO}$	Collector-base voltage ( $I_E = 0$ )		140	V
$V_{CEO}$	Collector-emitter voltage ( $I_B = 0$ )		80	V
$V_{EBO}$	Emitter-base voltage ( $I_C = 0$ )		7	V
$I_C$	Collector current		1	A
$P_{tot}$	Total dissipation at $T_{amb} = 25\text{ °C}$	for 2N3700HR	0.5	W
		for SOC3700HRB	0.5	W
		for SOC3700HRB <sup>(1)</sup>	0.76	W
	Total dissipation at $T_C = 25\text{ °C}$	for 2N3700HR	1.8	W
$T_{stg}$	Storage temperature		-65 to 200	°C
$T_J$	Max. operating junction temperature		200	°C

1. When mounted on a 15 x 15 x 0.6 mm ceramic substrate.

**Table 3. Thermal data**

Symbol	Parameter	LCC-3 and UB	TO-18	Unit
$R_{thJC}$	Thermal resistance junction-case (max) for JAN	-	-	°C/W
	Thermal resistance junction-case (max) for ESCC	350	97	
$R_{thJSP(IS)}$	Thermal resistance junction-solder pad (infinite sink) (max) for JAN	90	-	
	Thermal resistance junction-solder pad (infinite sink) (max) for ESCC	-	-	
$R_{thJA}$	Thermal resistance junction-ambient (max) for JAN	325	-	
	Thermal resistance junction-ambient (max) for ESCC	240 <sup>(1)</sup>	350	

1. When mounted on a 15 x 15 x 0.6 mm ceramic substrate.

## 2 Electrical characteristics

JANS and ESCC version of the products are assembled and tested in compliance with the agency specification it is qualified in. The electrical characteristics of each version are provided in dedicated tables.

$T_{case} = 25\text{ °C}$  unless otherwise specified.

### 2.1 JANS electrical characteristics

Table 4. JANS electrical characteristics

Symbol	Parameter	Test conditions	Min.	Typ.	Max.	Unit
$I_{CBO}$	Collector cut-off current ( $I_E = 0$ )	$V_{CB} = 140\text{ V}$		-	10	$\mu\text{A}$
$I_{CES}$	Collector cut-off current ( $I_E = 0$ )	$V_{CE} = 90\text{ V}$ $V_{CE} = 90\text{ V}, T_{amb} = 150\text{ °C}$		-	10 5	nA $\mu\text{A}$
$I_{EBO}$	Emitter cut-off current ( $I_C = 0$ )	$V_{EB} = 5\text{ V}$ $V_{EB} = 7\text{ V}$		-	10 10	nA $\mu\text{A}$
$V_{(BR)CEO}$	Collector-emitter breakdown voltage ( $I_B = 0$ )	$I_C = 30\text{ mA}$		-	80	V
$V_{CE(sat)}$	Collector-emitter saturation voltage	$I_C = 150\text{ mA}$ $I_B = 15\text{ mA}$ $I_C = 500\text{ mA}$ $I_B = 50\text{ mA}$		-	0.2 0.5	V V
$V_{BE(sat)}$	Base-emitter saturation voltage	$I_C = 150\text{ mA}$ $I_B = 15\text{ mA}$		-	1.1	V
$h_{FE}$	DC current gain	$I_C = 0.1\text{ mA}$ $V_{CE} = 10\text{ V}$	50	-	200	
		$I_C = 10\text{ mA}$ $V_{CE} = 10\text{ V}$	90	-		
		$I_C = 150\text{ mA}$ $V_{CE} = 10\text{ V}$	100	-	300	
		$I_C = 150\text{ mA}$ $V_{CE} = 10\text{ V}$ $T_{amb} = -55\text{ °C}$	40	-		
		$I_C = 500\text{ mA}$ $V_{CE} = 10\text{ V}$	50	-	200	
		$I_C = 1\text{ A}$ $V_{CE} = 10\text{ V}$	15	-		
$h_{fe}$	Small signal current gain	$V_{CE} = 5\text{ V}$ $I_C = 1\text{ mA}$ $f = 1\text{ kHz}$	80	-	400	
		$V_{CE} = 10\text{ V}$ $I_C = 50\text{ mA}$ $f = 20\text{ MHz}$	5	-	20	
$C_{obo}$	Output capacitance ( $I_E = 0$ )	$V_{EB} = 0.5\text{ V}$ 100 kHz; $f = 1\text{ MHz}$		-	12	pF
$C_{ibo}$	Output capacitance ( $I_E = 0$ )	$V_{EB} = 0.5\text{ V}$ 100 kHz; $f = 1\text{ MHz}$		-	60	pF



Table 4. JANS electrical characteristics (continued)

Symbol	Parameter	Test conditions	Min.	Typ.	Max.	Unit
NF	Noise figure	$V_{CE} = 10\text{ V}$ $I_C = 100\ \mu\text{A}$ $R_g = 1\ \text{k}\Omega$ , power bandwidth		-	4	dB
$r'_{b, Cc(1)}$	Collector-base time constant	$V_{CB} = 10\text{ V}$ ; $I_C = 10\text{ mA}$ ; $f = 79.8\text{ MHz}$		-	400	ps
$t_{off} + t_{off}$	Switching times	see circuit <a href="#">Figure 6</a>		-	30	ns

1. This parameter may be determined by applying an rf signal voltage of 1.0 volt (rms) across the collector-base terminals, and measuring the ac voltage drop ( $V_{eb}$ ) with a high-impedance rf voltmeter across the emitter-base terminals. With  $f = 79.8\text{ MHz}$  used for the 1.0 volt signal, the following computation applies:  $r'_{b, Cc(\text{ps})} = 2 \times V_{eb}$  (mV).

## 2.2 ESCC electrical characteristics

Table 5. ESCC 5201/004 electrical characteristics

Symbol	Parameter	Test conditions	Min.	Typ.	Max.	Unit
$I_{CBO}$	Collector cut-off current ( $I_E = 0$ )	$V_{CB} = 90\text{ V}$		-	10	nA
		$V_{CB} = 90\text{ V}$ , $T_{amb} = 150\text{ }^\circ\text{C}$		-	10	$\mu\text{A}$
$I_{EBO}$	Emitter cut-off current ( $I_C = 0$ )	$V_{EB} = 5\text{ V}$		-	10	nA
$V_{(BR)CBO}$	Collector-base breakdown voltage ( $I_E = 0$ )	$I_C = 100\ \mu\text{A}$	140	-		V
$V_{(BR)CEO(1)}$	Collector-emitter breakdown voltage ( $I_B = 0$ )	$I_C = 30\text{ mA}$	80	-		V
$V_{(BR)EBO}$	Emitter-base breakdown voltage ( $I_C = 0$ )	$I_E = 100\ \mu\text{A}$	7	-		V
$V_{CE(sat)(1)}$	Collector-emitter saturation voltage	$I_C = 150\text{ mA}$ $I_B = 15\text{ mA}$ $I_C = 500\text{ mA}$ $I_B = 50\text{ mA}$		-	0.2 0.5	V
$V_{BE(sat)(1)}$	Base-emitter saturation voltage	$I_C = 150\text{ mA}$ $I_B = 15\text{ mA}$ $I_C = 150\text{ mA}$ $I_B = 15\text{ mA}$ ; $T_{amb} = 110\text{ }^\circ\text{C}$		-	1 0.9	V
$h_{FE}$	DC current gain	$I_C = 10\text{ mA}$ , $V_{CE} = 10\text{ V}$	90	-		
		$I_C = 150\text{ mA}$ , $V_{CE} = 10\text{ V}$	100	-	300	
		$I_C = 500\text{ mA}$ , $V_{CE} = 10\text{ V}$	50	-		
		$I_C = 150\text{ mA}$ , $V_{CE} = 10\text{ V}$ ; $T_{amb} = -55\text{ }^\circ\text{C}$	40	-		
$h_{fe}$	Small signal current gain	$I_C = 50\text{ mA}$ , $V_{CE} = 10\text{ V}$ ; $f = 20\text{ MHz}$	5	-		

Table 5. ESCC 5201/004 electrical characteristics (continued)

Symbol	Parameter	Test conditions	Min.	Typ.	Max.	Unit
$C_{CBO}$	Output capacitance ( $I_E = 0$ )	$V_{CB} = 10\text{ V}, f = 1\text{ MHz}$		-	12	pF
$C_{IBO}$	Input capacitance ( $I_C = 0$ )	$V_{EB} = 0.5\text{ V}, f = 1\text{ MHz}$		-	60	pF

1. Pulsed duration = 300  $\mu\text{s}$ , duty cycle > 2 %

### 2.3 Electrical characteristics (curves)

Figure 2. DC current gain ( $V_{CE}=1\text{ V}$ )

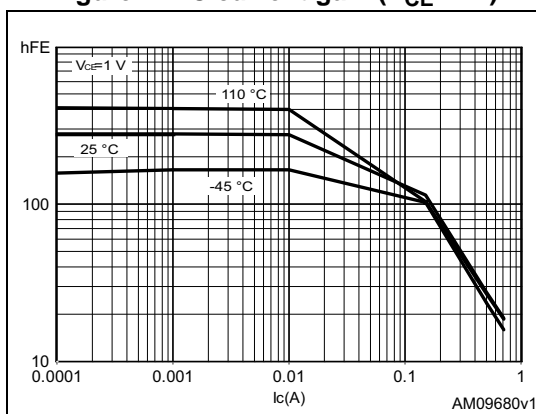

Figure 3. DC current gain ( $V_{CE}=10\text{ V}$ )

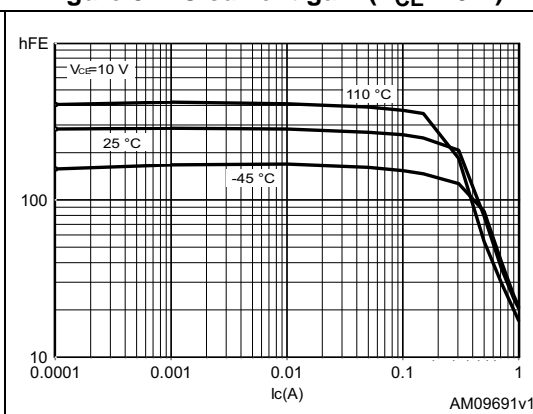

Figure 4. Collector emitter saturation voltage

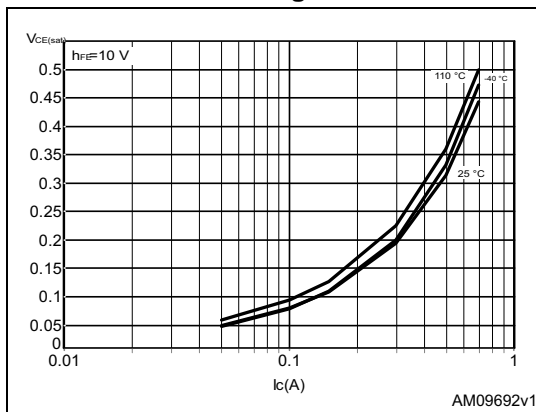
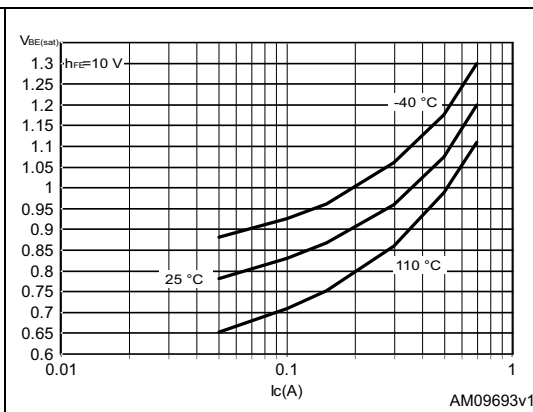

Figure 5. Base emitter saturation voltage



2.4 Test circuits

Figure 6. JANS non saturated switching-time test circuit

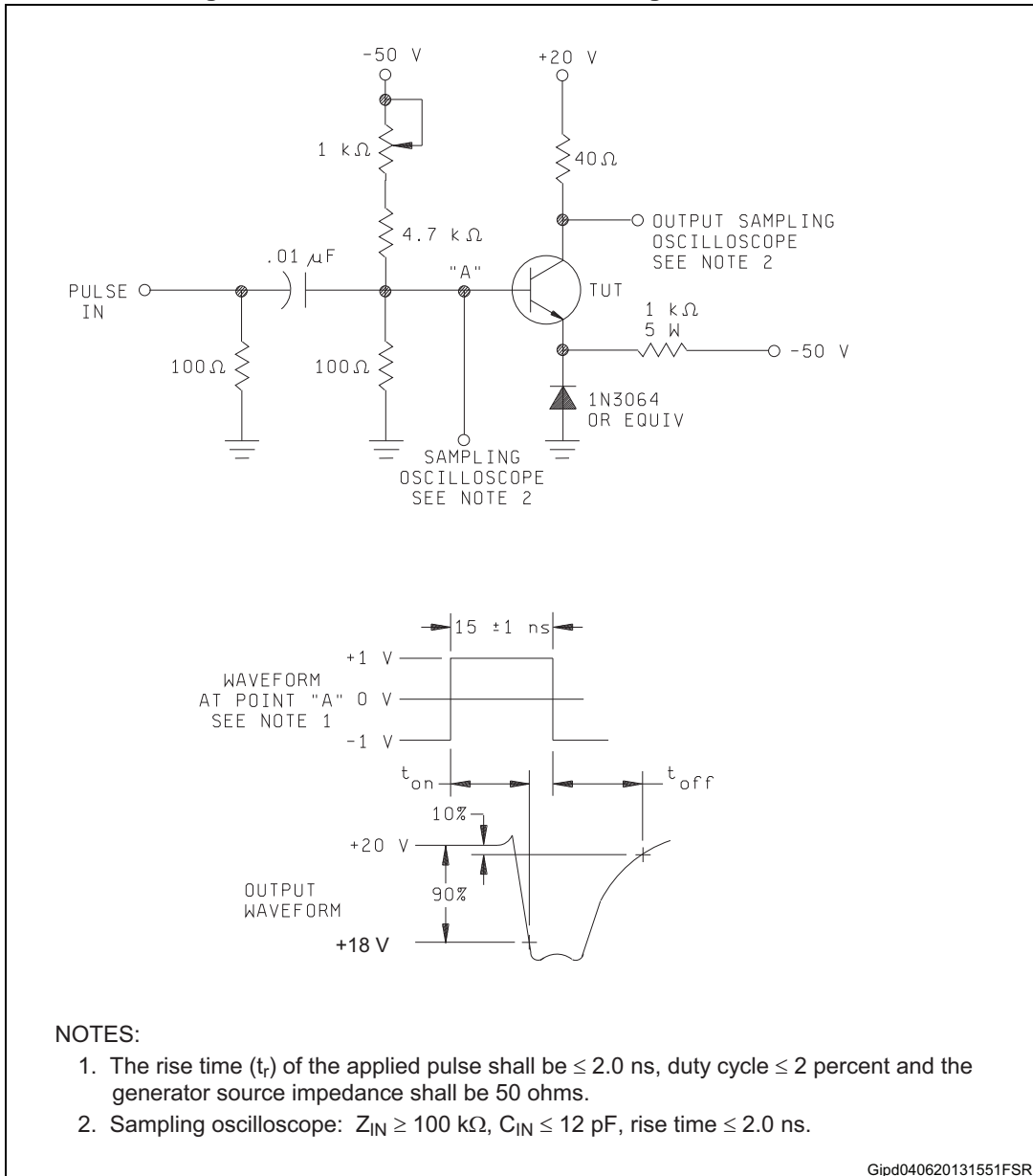
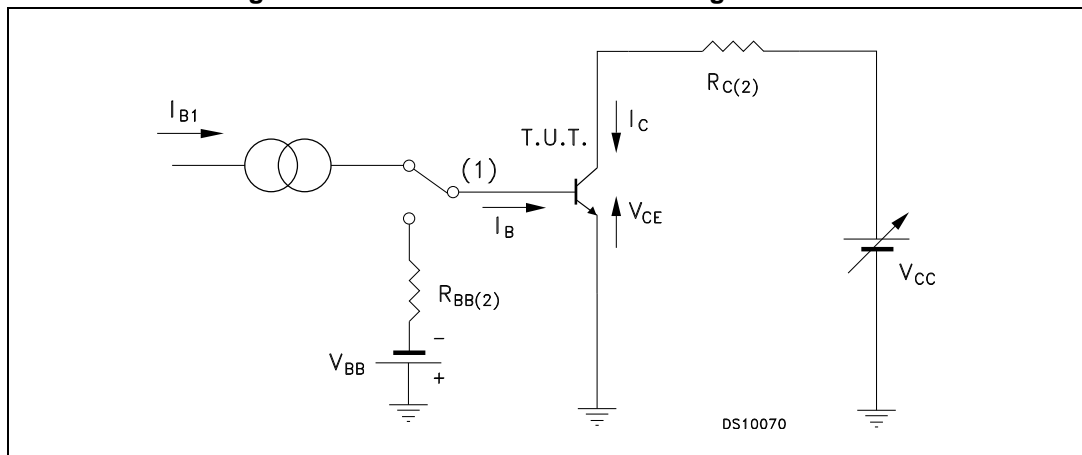

Figure 7. ESCC resistive load switching test circuit



- 1. Fast electronic switch
- 2. Non-inductive resistor



### 3 Radiation hardness assurance

The products guaranteed in radiation within the JANS system fully comply with the MIL-PRF-19500/255 specification.

The products guaranteed in radiation within the ESCC system fully comply with the ESCC 5201/004 and ESCC 22900 specifications.

#### JANS radiation assurance

ST JANS parts guaranteed at 100 krad (Si), tested, in full compliancy with the MIL-PRF-19500 specification, specifically the Group D, subgroup 2 inspection, between 50 and 300 rad/s. On top of the standard JANSR high dose rate by wafer lot guarantee, ST 2N3700HR series include an additional wafer by wafer 100 krad Low dose rate guarantee at 0.1 rad/s, identical to the ESCC 100 krad guarantee. It is supported with the same Radiation Verification Test report provided with each shipment. A brief summary of the standard High Dose Rate by wafer lot JANSR guarantee is provided below:

- All test are performed in accordance to MIL-PRF-19500 and test method 1019 of MIL-STD-750 for total ionizing dose.
- The table below provides for each monitored parameters of the test conditions and the acceptance criteria.

**Table 6. MIL-PRF-19500 (test method 1019) post radiation electrical characteristics**

Symbol	Parameter	Test conditions	Min.	Typ.	Max.	Unit
$I_{CBO}$	Collector cut-off current ( $I_E = 0$ )	$V_{CB} = 140 \text{ V}$		-	20	$\mu\text{A}$
$I_{CES}$	Collector-emitter cut-off current	$V_{CE} = 90 \text{ V}$		-	20	nA
$I_{EBO}$	Emitter cut-off current ( $I_C = 0$ )	$V_{EB} = 5 \text{ V}$ $V_{EB} = 7 \text{ V}$		-	20 20	nA $\mu\text{A}$
$V_{(BR)CEO}$	Collector-emitter breakdown voltage ( $I_B = 0$ )	$I_C = 30 \text{ mA}$		-	80	V
$V_{CE(sat)}$	Collector-emitter saturation voltage	$I_C = 150 \text{ mA}$ $I_B = 15 \text{ mA}$ $I_C = 500 \text{ mA}$ $I_B = 50 \text{ mA}$		-	0.23 0.58	V V
$V_{BE(sat)}$	Base-emitter saturation voltage	$I_C = 150 \text{ mA}$ $I_B = 15 \text{ mA}$		-	1.1	V
$[h_{FE}]$	Post irradiation gain calculation	$I_C = 150 \text{ mA}$ $V_{CE} = 10 \text{ V}$	[50] <sup>(1)</sup>	-	300	
		$I_C = 0.1 \text{ mA}$ $V_{CE} = 10 \text{ V}$	[25] <sup>(1)</sup>	-	200	
		$I_C = 10 \text{ mA}$ $V_{CE} = 10 \text{ V}$	[45] <sup>(1)</sup>	-		
		$I_C = 500 \text{ mA}$ $V_{CE} = 10 \text{ V}$	[25] <sup>(1)</sup>	-	200	
		$I_C = 1.0 \text{ A}$ $V_{CE} = 10 \text{ V}$	[7.5] <sup>(1)</sup>	-		

1. See method 1019 of MIL-STD-750 for how to determine  $[h_{FE}]$  by first calculating the delta ( $1/h_{FE}$ ) from the pre- and post-radiation  $h_{FE}$ . Notice the  $[h_{FE}]$  is not the same as  $h_{FE}$  and cannot be measured directly. The  $[h_{FE}]$  value can never exceed the pre-radiation minimum  $h_{FE}$  that it is based upon.

### ESCC radiation assurance

Each product lot is tested according to the ESCC basic specification 22900, with a minimum of 11 samples per diffusion lot and 5 samples per wafer, one sample being kept as unirradiated sample, all of them being fully compliant with the applicable ESCC generic and/or detailed specification.

ST goes beyond the ESCC specification by performing the following procedure:

- Test of 11 pieces by wafer, 5 biased at least 80% of  $V_{(BR)CEO}$ , 5 unbiased and 1 kept for reference
- Irradiation at 0.1 rad (Si)/s
- Acceptance criteria of each individual wafer if as 100 krad guaranteed if all 10 samples comply with the post radiation electrical characteristics provided in [Table 7: ESCC 5201/004 post radiation electrical characteristics](#)
- Delivery together with the parts of the radiation verification test (RVT) report of the particular wafer used to manufacture the products. This RVT includes the value of each parameter at 30, 50, 70 and 100 krad (Si) and after 24 hour annealing at room temperature and after an additional 168 hour annealing at 100°C.

**Table 7. ESCC 5201/004 post radiation electrical characteristics**

Symbol	Parameter	Test conditions	Min.	Typ.	Max.	Unit
$I_{CBO}$	Collector cut-off current ( $I_E = 0$ )	$V_{CB} = 90 \text{ V}$		-	10	nA
$I_{EBO}$	Emitter cut-off current ( $I_C = 0$ )	$V_{EB} = 5 \text{ V}$		-	10	nA
$V_{(BR)CBO}$	Collector-base breakdown voltage ( $I_E = 0$ )	$I_C = 100 \mu\text{A}$	140	-		V
$V_{(BR)CEO}^{(1)}$	Collector-emitter breakdown voltage ( $I_B = 0$ )	$I_C = 30 \text{ mA}$	80	-		V
$V_{(BR)EBO}$	Emitter-base breakdown voltage ( $I_C = 0$ )	$I_E = 100 \mu\text{A}$	7	-		V
$V_{CE(sat)}^{(1)}$	Collector-emitter saturation voltage	$I_C = 150 \text{ mA}$ $I_B = 15 \text{ mA}$ $I_C = 500 \text{ mA}$ $I_B = 50 \text{ mA}$		-	0.2 0.5	V V
$V_{BE(sat)}^{(1)}$	Base-emitter saturation voltage	$I_C = 150 \text{ mA}$ $I_B = 15 \text{ mA}$		-	1	V
$[h_{FE}]^{(1)}$	Post irradiation gain calculation <sup>(2)</sup>	$I_C = 10 \text{ mA}$ $V_{CE} = 10 \text{ V}$ $I_C = 150 \text{ mA}$ $V_{CE} = 10 \text{ V}$ $I_C = 500 \text{ mA}$ $V_{CE} = 10 \text{ V}$	[45] [50] [25]	-	[300]	

1. Pulsed duration = 300  $\mu\text{s}$ , duty cycle > 2 %

2. The post-irradiation gain calculation of  $[h_{FE}]$ , made using  $h_{FE}$  measurements from prior to and on completion of irradiation testing and after each annealing step if any, shall be as specified in MILSTD-750 method 1019.

Table 8. Radiation summary

Radiation test	100 krad ESCC
Wafer tested	each
Part tested	5 biased + 5 unbiased
Dose rate	0.1 rad/s
Acceptance	MIL-STD-750 method 1019
Displacement damage	Optional
Agency part number (ex)	5202/001/04R <sup>(1)</sup>
ST part number (ex)	SOC3700RHRG
Documents	CoC +RVT

1. Example of the 2N3700 in LCC-3 gold finish.

## 4 Package information

In order to meet environmental requirements, ST offers these devices in different grades of ECOPACK<sup>®</sup> packages, depending on their level of environmental compliance. ECOPACK<sup>®</sup> specifications, grade definitions and product status are available at: [www.st.com](http://www.st.com). ECOPACK<sup>®</sup> is an ST trademark.

## 4.1 UB package information

Figure 8. UB package outline

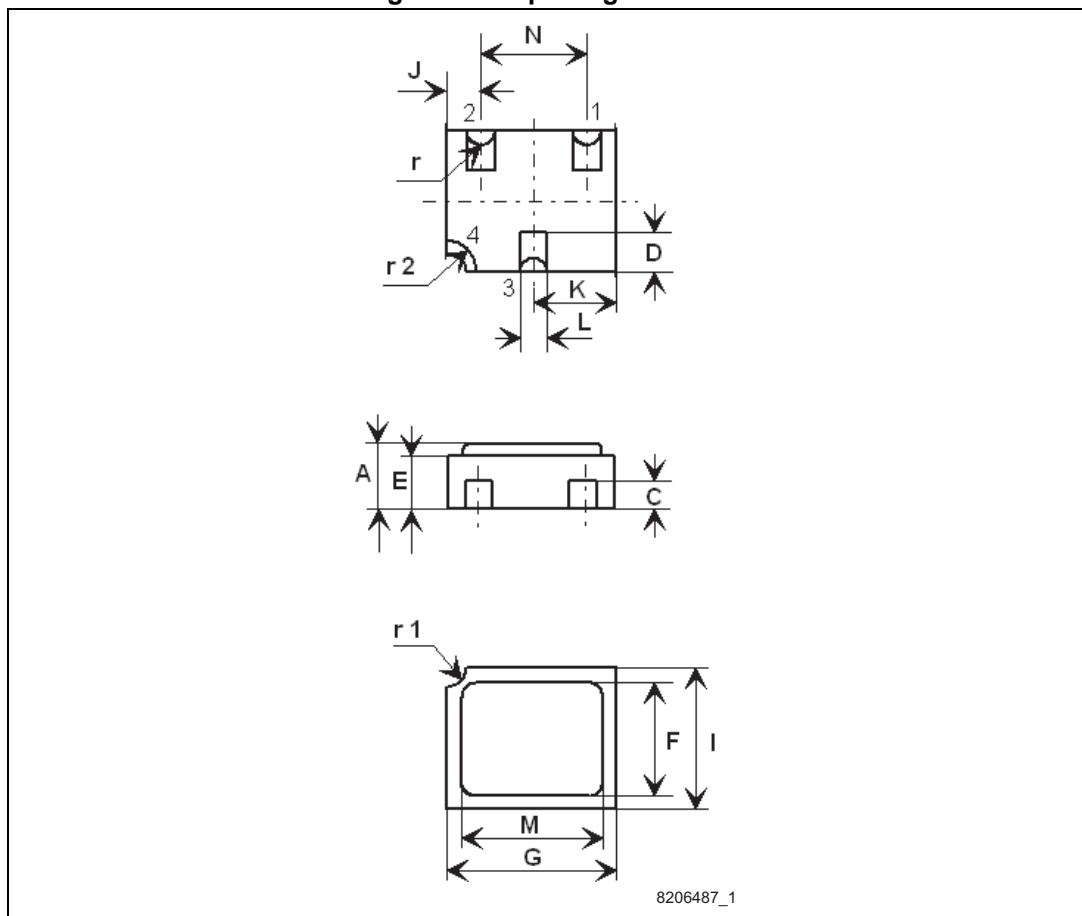

Table 9. UB package mechanical data

Dim.	mm.		
	Min.	Typ.	Max.
A	1.16		1.42
C	0.46	0.51	0.56
D	0.56	0.76	0.96
E	0.92	1.02	1.12
F	1.95	2.03	2.11
G	2.92	3.05	3.18
I	2.41	2.54	2.67
J	0.42	0.57	0.72
K	1.37	1.52	1.67
L	0.41	0.51	0.61
M	2.46	2.54	2.62
N	1.81	1.91	2.01
r		0.20	
r1		0.30	
r2		0.56	

## 4.2 LCC-3 package information

Figure 9. LCC-3 package outline

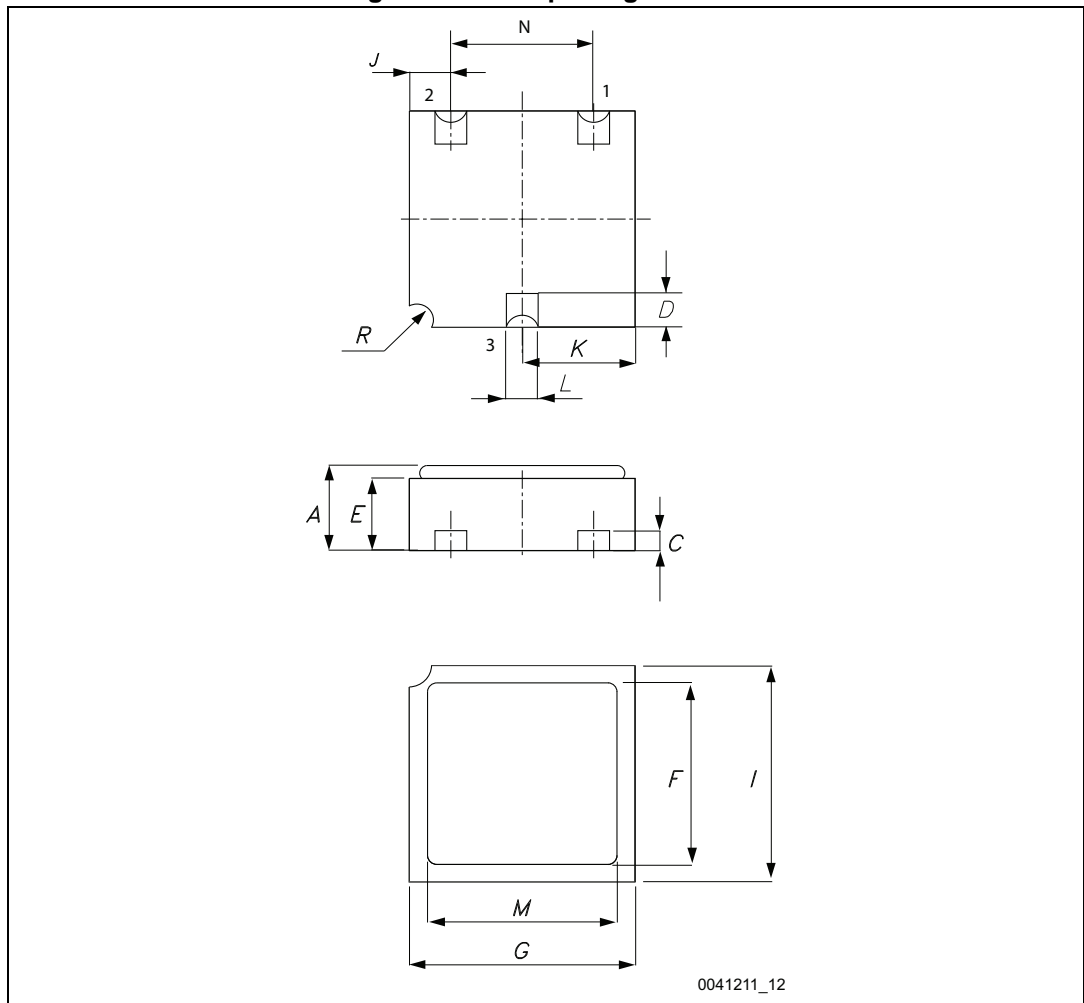

Table 10. LCC-3 package mechanical data

Dim.	mm.		
	Min.	Typ.	Max.
A	1.16		1.42
C	0.45	0.50	0.56
D	0.60	0.76	0.91
E	0.91	1.01	1.12
F	1.95	2.03	2.11
G	2.92	3.05	3.17
I	2.41	2.54	2.66
J	0.42	0.57	0.72
K	1.37	1.52	1.67
L	0.40	0.50	0.60
M	2.46	2.54	2.62
N	1.80	1.90	2.00
R		0.30	



### 4.3 TO-18 package information

Figure 10. TO-18 package outline

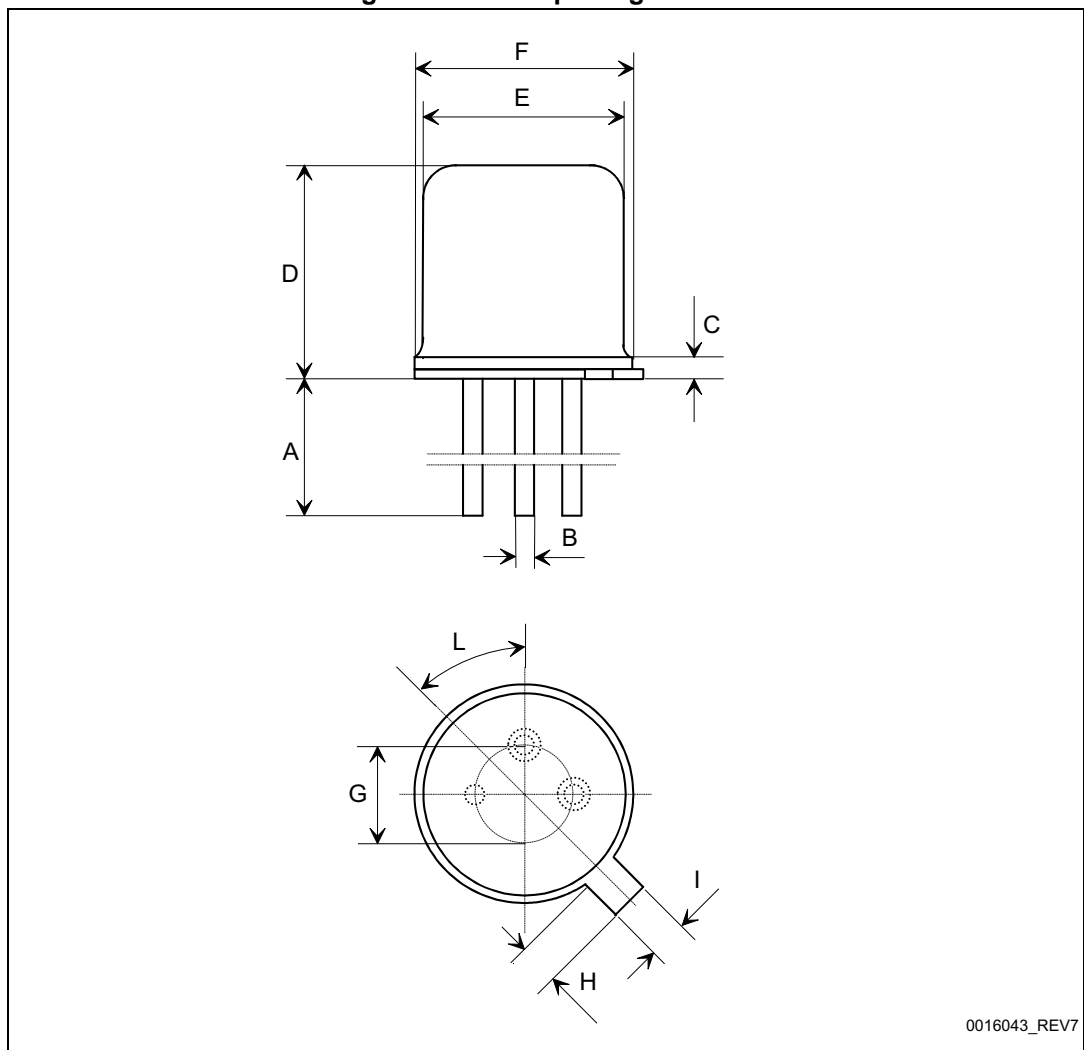

Table 11. TO-18 mechanical data

Dim.	mm.		
	Min.	Typ.	Max.
A	12.70	13.20	14.20
B	0.41	0.45	0.48
C	0.36		0.47
D	4.88		5.33
E	4.63		4.70
F	5.31		5.45
G	2.49	2.54	2.59
H	0.80	0.90	1.00
I	0.95	1.00	1.05
L	42°	45°	48°



## 5 Order codes

Table 12. Ordering information

CPN	Agency specification	EPPL	Quality level	Radiation level <sup>(1)</sup>	Package	Lead finish	Marking <sup>(2)</sup>	Packing
J2N3700UB1	-	-	Engineering model JANS	-	UB	Gold	J3700UB1	WafflePack
2N3700UB1	-	-	Engineering model ESCC	-	UB	Gold	2N3700UB1	WafflePack
SOC37001	-	-	Engineering model ESCC	-	LCC-3	Gold	SOC37001	WafflePack
JANSR2N3700UBG	MIL-PRF-19500/391	-	JANSR	100 krad high and low dose rate	UB	Gold	JSR3700	WafflePack
JANSR2N3700UBT	MIL-PRF-19500/391	-	JANSR	100 krad high and low dose rate	UB	Solder Dip	JSR3700	WafflePack
JANS2N3700UBG	MIL-PRF-19500/391	-	JANS	-	UB	Gold	JS3700	WafflePack
JANS2N3700UBT	MIL-PRF-19500/391	-	JANS	-	UB	Solder Dip	JS3700	WafflePack
2N3700RUBG	5201/004/06R	Target	ESCC Flight	100 krad low dose rate	UB	Gold	520100406R	WafflePack
2N3700RUBT	5201/004/07R	Target	ESCC Flight	100 krad low dose rate	UB	Solder Dip	520100407R	WafflePack
2N3700UBG	5201/004/06	Target	ESCC Flight	-	UB	Gold	520100406	WafflePack
2N3700UBT	5201/004/07	Target	ESCC Flight	-	UB	Solder Dip	520100407	WafflePack
SOC3700RHRG	5201/004/04R	Yes	ESCC Flight	100 krad low dose rate	LCC-3	Gold	520100404R	WafflePack
SOC3700RHRT	5201/004/05R	Yes	ESCC Flight	100 krad low dose rate	LCC-3	Solder Dip	520100405R	WafflePack
SOC3700HRG	5201/004/04	Yes	ESCC Flight	-	LCC-3	Gold	520100404	WafflePack

DocID15354 Rev 12

19/23

2N3700HR

Order codes



Table 12. Ordering information (continued)

CPN	Agency specification	EPPL	Quality level	Radiation level <sup>(1)</sup>	Package	Lead finish	Marking <sup>(2)</sup>	Packing
SOC3700HRT	5201/004/05	Yes	ESCC Flight	-	LCC-3	Solder Dip	520100405	WafflePack
2N3700HRHG	5201/004/01R	-	ESCC Flight	100 krad low dose rate	TO-18	Gold	520100401R	Strip Pack
2N3700RHRT	5201/004/02R	-	ESCC Flight	100 krad low dose rate	TO-18	Solder Dip	520100402R	Strip Pack
2N3700HRG	5201/004/01	-	ESCC Flight	-	TO-18	Gold	520100401	Strip Pack
2N3700HRT	5201/004/02	-	ESCC Flight	-	TO-18	Solder Dip	520100402	Strip Pack

1. High dose rate as per MIL-PRF-19500 specification group D, subgroup 2 inspection. Low dose rate as per ESCC specification 22900.
2. Specific marking only. The full marking includes in addition: the Engineering Models: ST logo, date code; country of origin (FR). For ESCC flight parts: ST logo, date code, country of origin (FR), ESA logo, serial number of the part within the assembly lot. For JANS flight parts: ST logo, date code, country of origin (FR), manufacturer code (CSTM), serial number of the part within the assembly lot.

Contact ST sales office for information about the specific conditions for:

- Products in die form
- Other JANS quality levels
- Tape and reel packing

## 6 Shipping details

### 6.1 Date code

Data code xyywwz is structured as described below:

**Table 13. Date code**

	x	yy	ww	z
EM (ESCC and JANS)	3	last two digits of the year	week digits	lot index in the week
ESCC flight	-			
JANS flight (diffused in Singapore)	W			

### 6.2 Documentation

**Table 14. Documentation provided for each type of product**

Quality level	Radiation level	Documentation
Engineering model	-	-
JANS Flight	-	Certificate of conformance
JANSR Flight	MIL-STD 100krad	Certificate of conformance 50 rad/s radiation verification test report
	ST 100Krad	Certificate of conformance 0.1 rad/s radiation verification test report on each wafer
ESCC Flight	-	Certificate of conformance
	100 krad	Certificate of conformance 0.1 rad/s radiation verification test report

## 7 Revision history

**Table 15. Document revision history**

Date	Revision	Changes
10-Jan-2008	1	Initial release
07-Jan-2010	2	Modified <a href="#">Table 1: Device summary</a>
26-Jul-2010	3	Modified <a href="#">Table 1: Device summary</a> , added <a href="#">Table 10 on page 15</a>
30-Nov-2011	4	<ul style="list-style-type: none"> <li>– Modified: <a href="#">Table 6 on page 9</a></li> <li>– Added: <a href="#">Section 2.3: Electrical characteristics (curves)</a></li> <li>– Minor text change in the document title on the coverpage</li> </ul>
17-Apr-2013	5	Added: <a href="#">Section 3: Radiation hardness assurance</a>
11-Jun-2013	6	<p>Updated order codes in <a href="#">Table 1: Device summary</a> and <a href="#">Table 12: Ordering information</a>.</p> <p>Updated <a href="#">Section 3: Radiation hardness assurance</a>.</p> <p>Minor text changes.</p>
18-Sep-2013	7	Updated order codes in <a href="#">Table 1: Device summary</a> and <a href="#">Table 12: Ordering information</a> .
25-Mar-2014	8	<p>Updated order codes in <a href="#">Table 1: Device summary</a> and <a href="#">Table 12: Ordering information</a>.</p> <p>Updated <a href="#">Section 3: Radiation hardness assurance</a>.</p>
29-May-2014	9	Updated <a href="#">Table 1: Device summary</a> and <a href="#">Table 12: Ordering information</a> .
29-Jul-2014	10	Updated <a href="#">Table 5: ESCC 5201/004 electrical characteristics</a> .
20-Jul-2015	11	<p>Updated <a href="#">Section 4: Package information</a>.</p> <p>Minor text changes.</p>
19-Aug-2015	12	<p>Updated <a href="#">Section 4.3: TO-18 package information</a>.</p> <p>Minor text changes.</p>

**IMPORTANT NOTICE – PLEASE READ CAREFULLY**

STMicroelectronics NV and its subsidiaries ("ST") reserve the right to make changes, corrections, enhancements, modifications, and improvements to ST products and/or to this document at any time without notice. Purchasers should obtain the latest relevant information on ST products before placing orders. ST products are sold pursuant to ST's terms and conditions of sale in place at the time of order acknowledgement.

Purchasers are solely responsible for the choice, selection, and use of ST products and ST assumes no liability for application assistance or the design of Purchasers' products.

No license, express or implied, to any intellectual property right is granted by ST herein.

Resale of ST products with provisions different from the information set forth herein shall void any warranty granted by ST for such product.

ST and the ST logo are trademarks of ST. All other product or service names are the property of their respective owners.

Information in this document supersedes and replaces information previously supplied in any prior versions of this document.

© 2015 STMicroelectronics – All rights reserved