

**SURFACE MOUNT
SCHOTTKY BARRIER RECTIFIER**

**REVERSE VOLTAGE – 40 Volts
FORWARD CURRENT – 1.0 Ampere**

FEATURES

- Low Forward Voltage Drop
- High Surge Capability and High Current Capability
- For Surface Mounted Applications
- High Conductance
- Guard Ring Construction for Transient Protection

MECHANICAL DATA

- Case: SOD-123 Plastic
- Case Material: “Green” molding compound, UL flammability classification 94V-0, (No Br. Sb. Cl)
- Moisture Sensitivity: Level 1 per J-STD-020D
- Lead Pb-Free in RoHS 2002/95/EC Compliant
- Weight: approx. 0.01 grams (approximate)

SOD-123

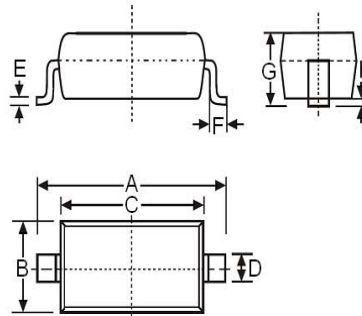

SOD-123		
Dim.	Min.	Max.
A	3.55	3.85
B	1.40	1.70
C	2.55	2.85
D	0.55 Typical	
E	0.11 Typical	
F	0.25	---
G	---	1.35
H	---	0.10
All Dimensions in millimeter		

Maximum Ratings and Thermal Characteristics @ T_A = 25°C unless otherwise specified

Characteristic	Symbol	Value	Units
Repetitive Peak Reverse Voltage	V _{RRM}	40	V
Working Peak Reverse Voltage	V _{RWM}		
DC Blocking Voltage	V _R		
RMS Reverse Voltage	V _{R(RMS)}	28	V
Forward Continuous Current (Note 1) @ TC=75°C	I _F	1.0	A
Non-Repetitive Peak Forward Surge Current 8.3ms Single half sine-wave superimposed on rated load (JEDEC Method)	I _{FSM}	25	A
Power Dissipation (Note 1)	P _D	450	mW
Thermal Resistance (Note 2)	R _{θJA}	230	°C/W
Operating and Storage Temperature Range	T _J , T _{STG}	-65 to +125	°C

Electrical Characteristics @ T_A = 25°C unless otherwise specified

Parameter	Symbol	Value	Unit	Test Condition
Minimum Reverse Breakdown Voltage	V _{(BR)R}	40	V	I _R = 1.0mA
Maximum Forward Voltage	V _F	320	mV	IF = 0.1A
		450		IF = 1.0A
		750		IF = 3.0A
Maximum DC Reverse Current at Rated DC Blocking Voltage	I _R	50	uA	VR = 4.0V, T _J = 25°C
		75		VR = 6.0V, T _J = 25°C
		1.0	mA	VR = 40V, T _J = 25°C
		10		VR = 40V, T _J = 100°C
		2.0		VR = 4.0V, T _J = 100°C
3.0	VR = 6.0V, T _J = 100°C			
Typical Junction Capacitance	C _J	70	pF	V _R = 4V DC, f = 1.0MHz

Note :

- (1) Unit mounted with 7.0*7.0mm copper pad areas
- (2) Thermal Resistance Junction to Ambient,

REV. 0, Feb-2009, KSHR01

FIG.1- FORWARD CURRENT DERATING CURVE

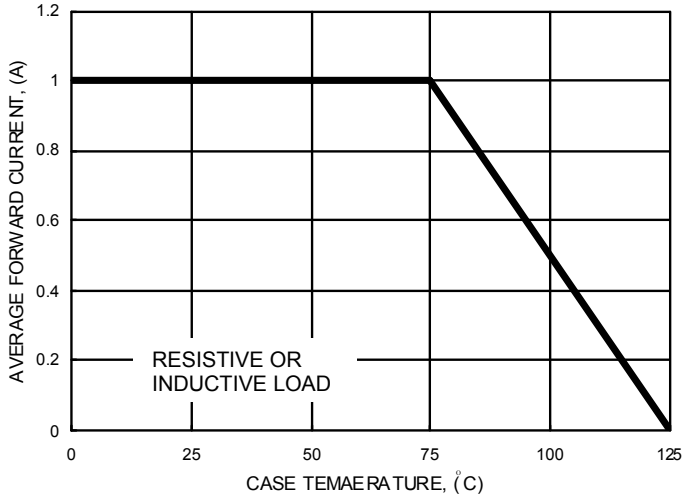

FIG.2- TYPICAL JUNCTION CAPACITANCE

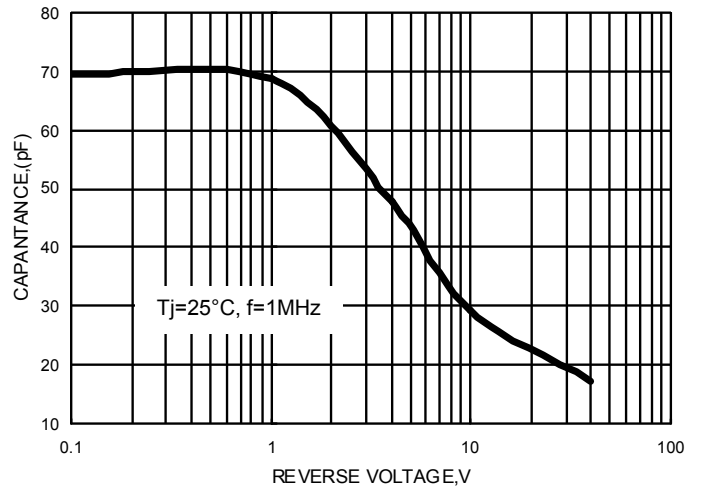

FIG.3- TYPICAL FORWARD CHARACTERISTICS

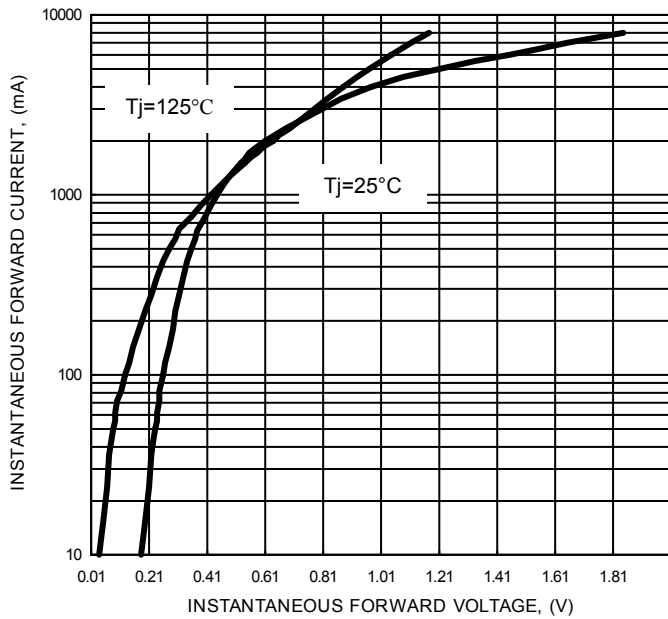

FIG.4- TYPICAL REVERSE CHARACTERISTICS

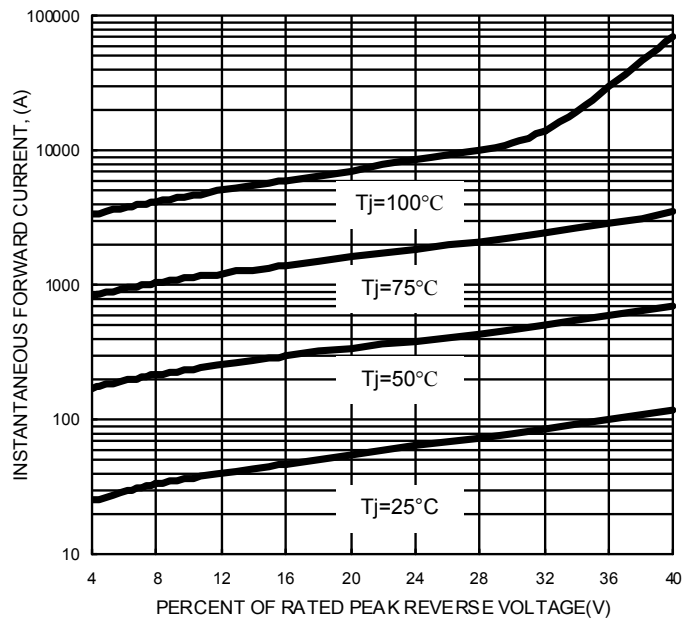

FIG.5- MAXIMUM NON-REPETITIVE SURGE CURRENT

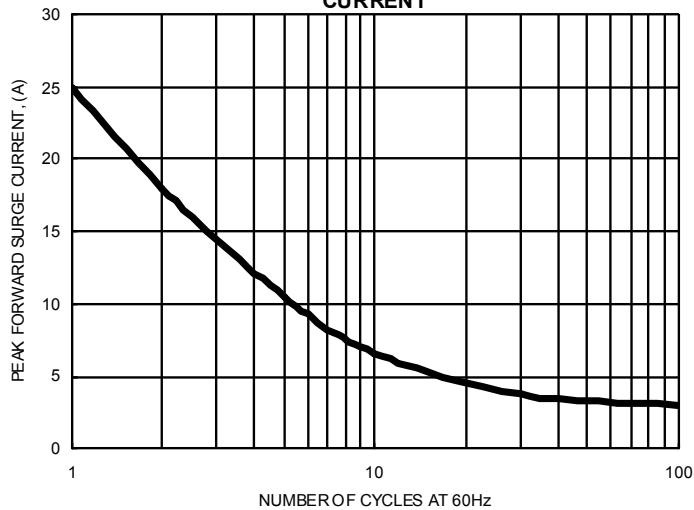

FIG.6- DC REVERSE VOLTAGE DERATING CURVE

