

NTC/PTC Thermistors for Automotive

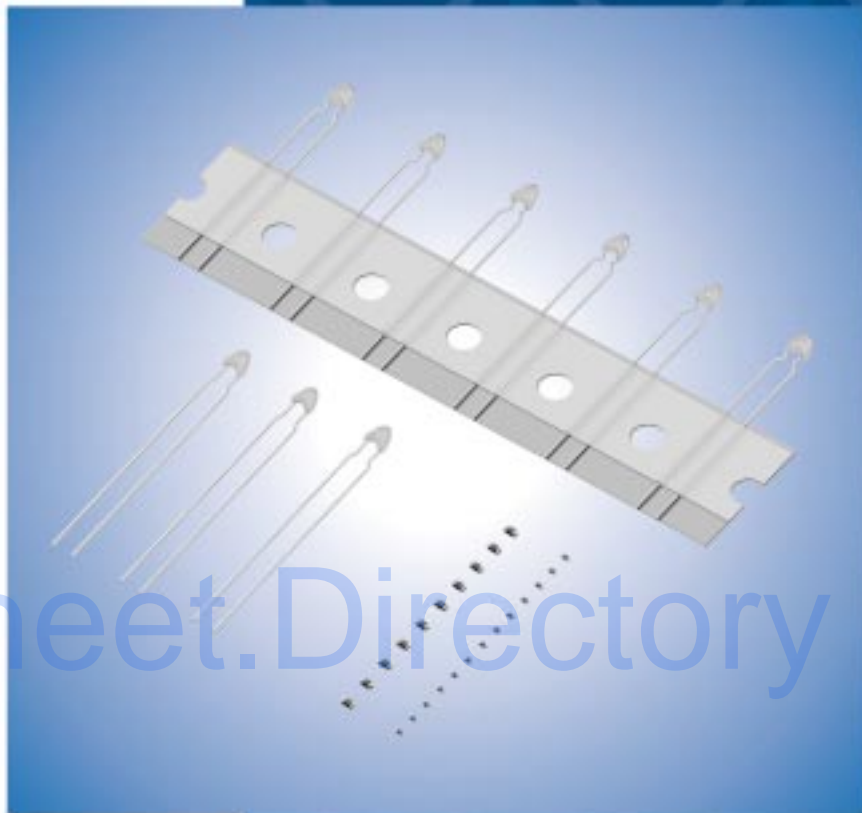

Datasheet.Directory

CONTENTS

POSISTOR® and "POSISTOR" in this catalog are the trademarks of Murata Manufacturing Co., Ltd.

| | | |
|---|-------|----|
| Part Numbering | _____ | 2 |
| Basic Characteristics of NTC Thermistor | _____ | 5 |
| Basic Characteristics of POSISTOR® | _____ | 6 |
| 1 NTC Thermistor Chip Type 0402 (1005) Size | _____ | 7 |
| 2 NTC Thermistor Chip Type 0603 (1608) Size | _____ | 9 |
| 3 NTC Thermistor Chip Type 0805 (2012) Size | _____ | 11 |
| for NTC Thermistors Chip Type Temperature Characteristics (Center Value) | _____ | 12 |
| for NTC Thermistors Chip Type Specifications and Test Methods | _____ | 15 |
| for NTC Thermistors Chip Type ⚠Caution/Notice | _____ | 17 |
| 4 NTC Thermistor Lead Type for Temperature Sensor | _____ | 21 |
| ● for NTC Thermistors Lead Type Temperature Characteristics (Center Value) | _____ | 22 |
| ● for NTC Thermistors Lead Type Specifications and Test Methods | _____ | 23 |
| ● for NTC Thermistors Lead Type ⚠Caution/Notice | _____ | 24 |
| 5 PTC Thermistor (POSISTOR®) for Overheat Sensing Chip Type 0603 (1608) Size | _____ | 25 |
| ● Chip Type of POSISTOR® for Overheat Protection Specifications and Test Methods | _____ | 28 |
| 6 PTC Thermistor (POSISTOR®) for Overcurrent Protection Chip Type 0805 (2012) Size | _____ | 30 |
| ● Chip Type of POSISTOR® for Overheat Protection Specifications and Test Methods | _____ | 32 |
| for POSISTOR® Chip Type ⚠Caution/Notice | _____ | 34 |
| 7 PTC Thermistor (POSISTOR®) for Overcurrent Protection Lead Type | _____ | 40 |
| ● POSISTOR® Lead Type for Overheat Protection Specifications and Test Methods | _____ | 48 |
| ● POSISTOR® Lead Type for Overheat Protection ⚠Caution/Notice | _____ | 50 |
| for NTC Thermistors Chip Type Package | _____ | 51 |
| for NTC Thermistors Lead Type Package | _____ | 54 |
| for POSISTOR® Chip Type Package | _____ | 55 |
| for POSISTOR® Lead Type Package | _____ | 56 |

1

2

3

4

5

6

7

● Part Numbering

NTC Thermistors for Temperature Compensation Chip Type



① Product ID

| Product ID | |
|------------|---------------------------|
| NC | NTC Thermistors Chip Type |

② Series

| Code | Series |
|----------|-----------------------------|
| M | Soldered Termination Series |
| P | Plated Termination Series |

③ Dimensions (L×W)

| Code | Dimensions (L×W) | EIA |
|-----------|------------------|------|
| 15 | 1.00×0.50mm | 0402 |
| 18 | 1.60×0.80mm | 0603 |
| 21 | 2.00×1.25mm | 0805 |

④ Temperature Characteristics

| Code | Temperature Characteristics |
|-----------|-------------------------------|
| WB | Nominal B-Constant 4050–4099K |
| WD | Nominal B-Constant 4150–4199K |
| WF | Nominal B-Constant 4250–4299K |
| WL | Nominal B-Constant 4450–4499K |
| WM | Nominal B-Constant 4500–4549K |
| XC | Nominal B-Constant 3100–3149K |
| XF | Nominal B-Constant 3250–3299K |
| XQ | Nominal B-Constant 3650–3699K |
| XH | Nominal B-Constant 3350–3399K |
| XM | Nominal B-Constant 3500–3549K |
| XV | Nominal B-Constant 3900–3949K |
| XW | Nominal B-Constant 3950–3999K |

⑤ Resistance

Expressed by three figures. The unit is ohm (Ω). The first and second figures are significant digits, and the third figure expresses the number of zeros which follow the two figures. If there is a decimal point, it is expressed by the capital letter "R". In this case, all figures are significant digits.

Ex.)

| Code | Resistance |
|------------|---------------|
| 102 | 1k Ω |
| 103 | 10k Ω |
| 104 | 100k Ω |

⑥ Resistance Tolerance

| Code | Resistance Tolerance |
|----------|----------------------|
| E | ±3% |
| F | ±1% |
| J | ±5% |
| K | ±10% |

⑦ Individual Specifications

Structures and others are expressed by two figures.

| Code | Individual Specifications |
|-----------|---------------------------|
| 0S | for Automotive |

⑧ Packaging

| Code | Packaging |
|-----------|-------------------------------------|
| RB | Paper Taping 4mm Pitch |
| RC | Paper Taping 2mm Pitch (10000 pcs.) |

NTC Thermistors for Temperature Sensor Lead Type

(Part Number)

| | | | | | | |
|----|-----|----|-----|---|----|----|
| NT | SS0 | XH | 103 | F | E1 | B0 |
| ① | ② | ③ | ④ | ⑤ | ⑥ | ⑦ |

① Product ID

| Product ID | |
|------------|-----------------|
| NT | NTC Thermistors |

② Series

| Code | Series |
|------------|--|
| SS0 | Temperature Sensors for Automotive Equipment |

③ Temperature Characteristics

| Code | Temperature Characteristics |
|-----------|-------------------------------|
| WB | Nominal B-Constant 4050–4099K |
| WC | Nominal B-Constant 4100–4149K |
| WD | Nominal B-Constant 4150–4199K |
| WF | Nominal B-Constant 4250–4299K |
| XM | Nominal B-Constant 3500–3549K |
| XH | Nominal B-Constant 3350–3399K |
| XR | Nominal B-Constant 3700–3749K |
| XV | Nominal B-Constant 3900–3949K |

④ Resistance

Expressed by three figures. The unit is ohm (Ω). The first and second figures are significant digits, and the third figure expresses the number of zeros which follow the two figures. If there is a decimal point, it is expressed by the capital letter "R". In this case, all figures are significant digits.

Ex.)

| Code | Resistance |
|------------|--------------|
| 202 | 2k Ω |
| 203 | 20k Ω |

⑤ Resistance Tolerance

| Code | Resistance Tolerance |
|----------|----------------------|
| E | ±3% |
| F | ±1% |

⑥ Individual Specifications

A lead structure and other specifications are expressed by two digits.

| Code | Individual Specifications |
|-----------|---------------------------|
| E1 | Bulk |
| N6 | Standard Taping |

⑦ Packaging

| Code | Packaging |
|-----------|-----------|
| A0 | Ammo Pack |
| B0 | Bulk |

PTC Thermistors (POSISTOR[®]) for Overheat Sensing Chip Type

(Part Number)

| | | | | | | | |
|----|---|----|----|-----|---|----|----|
| PR | F | 18 | BB | 471 | Q | S2 | RB |
| ① | ② | ③ | ④ | ⑤ | ⑥ | ⑦ | ⑧ |

① Product ID

| Product ID | |
|------------|---------------------------|
| PR | PTC Thermistors Chip Type |

② Series

| Code | Series |
|----------|----------------------|
| F | for Overheat Sensing |

③ Dimensions (L×W)

| Code | Dimensions (L×W) |
|-----------|------------------|
| 18 | 1.60×0.80mm |

④ Temperature Characteristics

| Code | Temperature Characteristics |
|-----------|-----------------------------|
| AR | Curie Point 120°C |
| AS | Curie Point 130°C |
| BA | Curie Point 110°C |
| BB | Curie Point 100°C |
| BC | Curie Point 90°C |
| BD | Curie Point 80°C |
| BE | Curie Point 70°C |
| BF | Curie Point 60°C |
| BG | Curie Point 50°C |

⑤ Resistance

Expressed by three figures. The unit is ohm (Ω). The first and second figures are significant digits, and the third figure expresses the number of zeros which follow the two figures. If there is a decimal point, it is expressed by the capital letter "R". In this case, all figures are significant digits.

Ex.)

| Code | Resistance |
|------------|--------------|
| 471 | 470 Ω |

⑥ Resistance Tolerance

| Code | Resistance Tolerance | Sensing Temp. Tolerance |
|----------|----------------------|-------------------------|
| Q | Special Tolerance | ±5°C |
| R | Special Tolerance | ±3°C |

⑦ Individual Specifications

| Code | Individual Specifications |
|-----------|---------------------------|
| S2 | for Automotive |

⑧ Packaging

| Code | Packaging |
|-----------|--------------------------|
| RB | Paper Taping (4mm Pitch) |

PTC Thermistors (POSISTOR®) for Circuit Protection

(Part Number)

| | | | | | | | |
|----|---|----|----|-----|---|----|----|
| PR | G | 21 | AR | 420 | M | S1 | RA |
| ① | ② | ③ | ④ | ⑤ | ⑥ | ⑦ | ⑧ |

① Product ID

| Product ID | |
|------------|---------------------------|
| PR | PTC Thermistors Chip Type |

② Series

| Code | Series |
|----------|----------------------------|
| G | for Overcurrent Protection |

③ Dimensions (L×W)

| Code | Dimensions (L×W) |
|-----------|------------------|
| 21 | 2.00×1.25mm |

④ Temperature Characteristics

| Code | Temperature Characteristics |
|-----------|-----------------------------|
| AR | Curie Point 120°C |

⑤ Resistance

Expressed by three figures. The unit is ohm (Ω). The first and second figures are significant digits, and the third figure expresses the number of zeros which follow the two figures. If there is a decimal point, it is expressed by the capital letter "R". In this case, all figures are significant digits.

Ex.)

| Code | Resistance |
|------------|------------|
| 420 | 42Ω |
| 471 | 470Ω |

⑥ Resistance Tolerance

| Code | Resistance Tolerance |
|----------|----------------------|
| M | ±20% |
| Q | Special Tolerance |

⑦ Individual Specifications

| Code | Individual Specifications |
|-----------|---------------------------|
| S1 | for Automotive |

⑧ Packaging

| Code | Packaging |
|-----------|---------------------------------------|
| RA | Plastic Taping (4mm Pitch) (4000pcs.) |
| RK | Plastic Taping (4mm Pitch) (3000pcs.) |

PTC Thermistors (POSISTOR®) for Circuit Protection Lead Type

(Part Number)

| | | | | | | | | |
|----|----|---|---|----|-----|---|------|----|
| PT | GL | 4 | S | AS | 220 | K | 4B51 | B0 |
| ① | ② | ③ | ④ | ⑤ | ⑥ | ⑦ | ⑧ | ⑨ |

① Product ID

| Product ID | |
|------------|-----------------|
| PT | PTC Thermistors |

② Series

| Code | Series |
|-----------|----------------------------------|
| GL | for Circuit Protection Lead Type |

③ Dimensions

| Code | Dimensions |
|----------|-----------------------------------|
| 4 | Nominal Body Diameter 4mm Series |
| 5 | Nominal Body Diameter 5mm Series |
| 7 | Nominal Body Diameter 7mm Series |
| 9 | Nominal Body Diameter 9mm Series |
| C | Nominal Body Diameter 12mm Series |

④ Individual Specifications

| Code | Individual Specifications |
|----------|---------------------------|
| S | for Automotive |

⑤ Temperature Characteristics

| Code | Temperature Characteristics |
|-----------|-----------------------------|
| AS | Curie Point 130°C |

⑥ Resistance

Expressed by three figures. The unit is ohm (Ω). The first and second figures are significant digits, and the third figure expresses the number of zeros which follow the two figures. If there is a decimal point, it is expressed by the capital letter "R". In this case, all figures are significant digits.

Ex.)

| Code | Resistance |
|------------|------------|
| R22 | 0.22Ω |
| 2R2 | 2.2Ω |
| 220 | 22Ω |

⑦ Resistance Tolerance

| Code | Resistance Tolerance |
|----------|----------------------|
| K | ±10% |

⑧ Individual Specifications

Ex.)

| Code | Individual Specifications |
|-------------|---------------------------|
| 4B51 | Lead Type, others |

⑨ Packaging

| Code | Packaging |
|-----------|-----------|
| A0 | Ammo Pack |
| B0 | Bulk |

Basic Characteristics of NTC Thermistor

■ Basic Characteristics

1. Zero-power Resistance of Thermistor: R

Measured by zero-power in specified ambient temperatures.

$$R = R_0 \exp B (1/T - 1/T_0) \quad \dots\dots\dots (1)$$

R: Resistance in ambient temperature T (K)
 (K: absolute temperature)

R₀: Resistance in ambient temperature T₀ (K)

B: B-constant of Thermistor

2. B-Constant

as (1) formula

$$B = \ell n (R/R_0) / (1/T - 1/T_0) \quad \dots\dots\dots (2)$$

3. Thermal Dissipation Constant

When electric power P (mW) is spent in ambient temperature T₁ and thermistor temperature rises T₂, there is a formula as follows

$$P = C (T_2 - T_1) \quad \dots\dots\dots (3)$$

C: Thermal dissipation constant (mW/°C)

Thermal dissipation constant is varied with dimensions, measurement conditions, etc.

4. Thermal Time Constant

Period in which Thermistor's temperature will change 63.2% of its temperature difference from ambient temperature T₀ (°C) to T₁ (°C).

5. Rated Electric Power

Shows necessary electric power that Thermistor's temperature rises 100°C by self heating in ambient temperature 25°C.

6. Permissive Operating Current

It is possible to keep Thermistor's temperature rising max. 1°C.

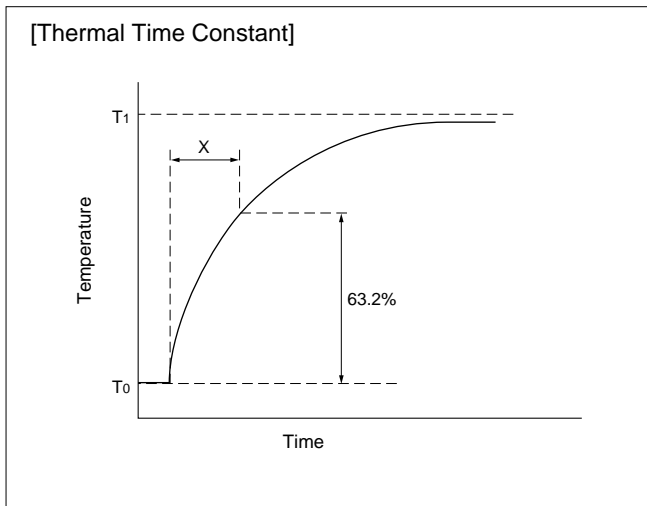
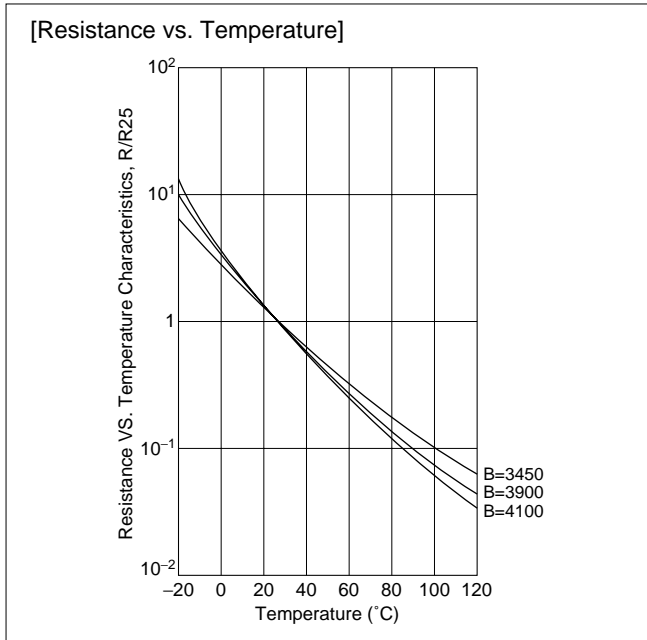

Basic Characteristics of POSISTOR®

Basic Characteristics

POSISTOR® has three main characteristics.

1. Resistance-Temperature Characteristic

Although there is a negligible difference between the normal and "Curie-point" temperature, POSISTOR® shows almost constant resistance-temperature characteristics. Yet they have resistance-temperature characteristics that cause resistance to sharply increase when the temperature exceeds the Curie-point.

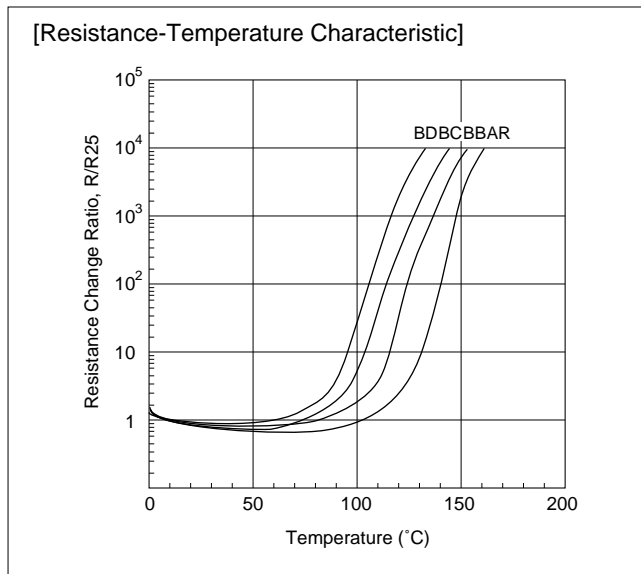

2. Current-Voltage Characteristic (Static Characteristic)

This shows the relation between applied voltage when voltage applied to POSISTOR® causes balancing of inner heating and outer thermal dissipation and stabilized current. This has both a maximum point of current and constant output power.

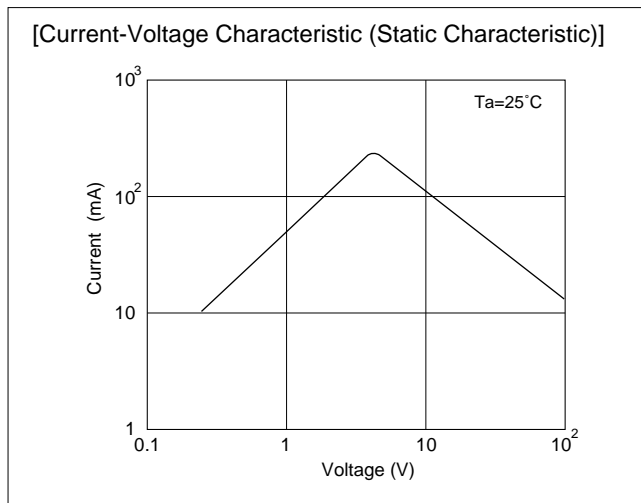

3. Current-Time Characteristic (Dynamic Characteristic)

This shows the relation between current and time before inner heating and outer thermal dissipation arrive at equilibrium state. This features having large initial current and abruptly continuous attenuating portion.

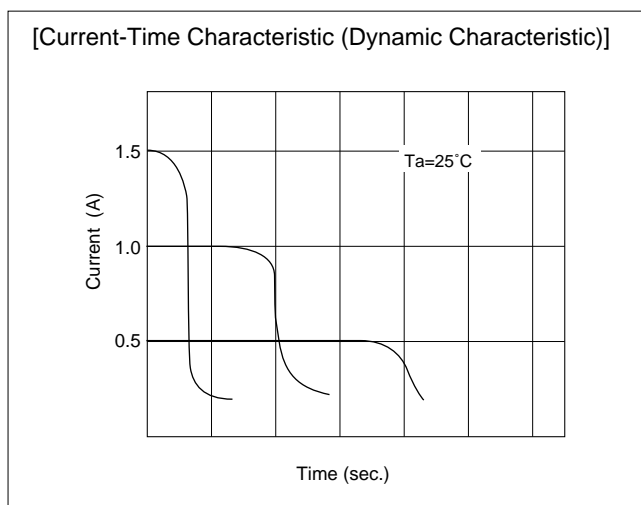

NTC/PTC Thermistors for Automotive



NTC Thermistor Chip Type 0402 (1005) Size

0402/0603 sized Chip NTC Thermistors have Ni barrier termination and provide excellent solderability and offer high stability in environment by unique inner construction.

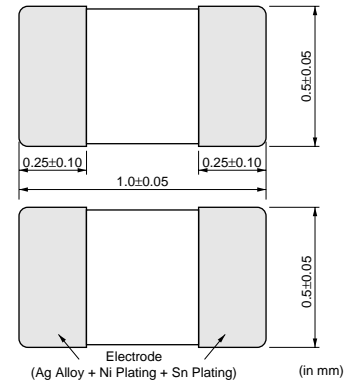
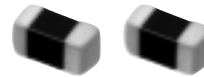

■ Features

1. Excellent solderability and high stability in environment
2. Excellent long time aging stability
3. High accuracy in resistance and B-constant
4. Reflow soldering possible
5. Lead is not contained in the product
6. NCP15 series are recognized by UL (UL1434, File No.E137188 Vol.2, Sec.2).

■ Applications

1. Car audio, car navigation
2. Various engine control units
3. Circuits for ETC equipment
4. Various motor driving circuits
5. Temperature compensation for various circuits

| Part Number | Resistance (25°C) | B-Constant (25-50°C) (K) | Permissible Operating Current (25°C) (mA) | Rated Electric Power (25°C) (mW) | Typical Dissipation Constant (25°C) (mW/°C) | Operating Temperature Range (°C) |
|-----------------|-------------------|--------------------------|---|----------------------------------|---|----------------------------------|
| NCP15XC220□0SRC | 22ohm | 3100 ±3% | 6.70 | 100 | 1.0 | -40 to 125 |
| NCP15XC330□0SRC | 33ohm | 3100 ±3% | 5.50 | 100 | 1.0 | -40 to 125 |
| NCP15XC470□0SRC | 47ohm | 3100 ±3% | 4.60 | 100 | 1.0 | -40 to 125 |
| NCP15XC680□0SRC | 68ohm | 3100 ±3% | 3.80 | 100 | 1.0 | -40 to 125 |
| NCP15XF101□0SRC | 100ohm | 3250 ±3% | 3.10 | 100 | 1.0 | -40 to 125 |
| NCP15XF151□0SRC | 150ohm | 3250 ±3% | 2.50 | 100 | 1.0 | -40 to 125 |
| NCP15XM221□0SRC | 220ohm | 3500 ±3% | 2.10 | 100 | 1.0 | -40 to 125 |
| NCP15XM331□0SRC | 330ohm | 3500 ±3% | 1.70 | 100 | 1.0 | -40 to 125 |
| NCP15XQ471□0SRC | 470ohm | 3650 ±2% | 1.40 | 100 | 1.0 | -40 to 125 |
| NCP15XQ681□0SRC | 680ohm | 3650 ±3% | 1.20 | 100 | 1.0 | -40 to 125 |
| NCP15XQ102□0SRC | 1.0k ohm | 3650 ±2% | 1.00 | 100 | 1.0 | -40 to 125 |
| NCP15XW152□0SRC | 1.5k ohm | 3950 ±3% | 0.81 | 100 | 1.0 | -40 to 125 |
| NCP15XW222□0SRC | 2.2k ohm | 3950 ±3% | 0.67 | 100 | 1.0 | -40 to 125 |
| NCP15XW332□0SRC | 3.3k ohm | 3950 ±3% | 0.55 | 100 | 1.0 | -40 to 125 |
| NCP15XM472□0SRC | 4.7k ohm | 3500 ±2% | 0.46 | 100 | 1.0 | -40 to 125 |
| NCP15XW682□0SRC | 6.8k ohm | 3950 ±3% | 0.38 | 100 | 1.0 | -40 to 125 |
| NCP15XH103□0SRC | 10k ohm | 3380 ±1% | 0.31 | 100 | 1.0 | -40 to 125 |
| NCP15XV103□0SRC | 10k ohm | 3900 ±3% | 0.31 | 100 | 1.0 | -40 to 125 |
| NCP15XW153□0SRC | 15k ohm | 3950 ±3% | 0.25 | 100 | 1.0 | -40 to 125 |
| NCP15WL223□0SRC | 22k ohm | 4485 ±1% | 0.21 | 100 | 1.0 | -40 to 125 |
| NCP15XW223□0SRC | 22k ohm | 3950 ±3% | 0.21 | 100 | 1.0 | -40 to 125 |
| NCP15WB333□0SRC | 33k ohm | 4050 ±3% | 0.17 | 100 | 1.0 | -40 to 125 |
| NCP15WL333□0SRC | 33k ohm | 4485 ±3% | 0.17 | 100 | 1.0 | -40 to 125 |
| NCP15WB473□0SRC | 47k ohm | 4050 ±1% | 0.14 | 100 | 1.0 | -40 to 125 |
| NCP15WL473□0SRC | 47k ohm | 4485 ±1% | 0.14 | 100 | 1.0 | -40 to 125 |
| NCP15WD683□0SRC | 68k ohm | 4150 ±3% | 0.12 | 100 | 1.0 | -40 to 125 |
| NCP15WL683□0SRC | 68k ohm | 4485 ±1% | 0.12 | 100 | 1.0 | -40 to 125 |
| NCP15WF104□0SRC | 100k ohm | 4250 ±1% | 0.10 | 100 | 1.0 | -40 to 125 |

Continued on the following page.

Continued from the preceding page.

| Part Number | Resistance (25°C) | B-Constant (25-50°C) (K) | Permissible Operating Current (25°C) (mA) | Rated Electric Power (25°C) (mW) | Typical Dissipation Constant (25°C) (mW/°C) | Operating Temperature Range (°C) |
|------------------------|-------------------|--------------------------|---|----------------------------------|---|----------------------------------|
| NCP15WL104□0SRC | 100k ohm | 4485 ±1% | 0.10 | 100 | 1.0 | -40 to 125 |
| NCP15WL154□0SRC | 150k ohm | 4485 ±1% | 0.08 | 100 | 1.0 | -40 to 125 |
| NCP15WM154□0SRC | 150k ohm | 4500 ±3% | 0.08 | 100 | 1.0 | -40 to 125 |
| NCP15WM224□0SRC | 220k ohm | 4500 ±3% | 0.06 | 100 | 1.0 | -40 to 125 |
| NCP15WM474□0SRC | 470k ohm | 4500 ±3% | 0.04 | 100 | 1.0 | -40 to 125 |

A blank column is filled with resistance tolerance codes. (J: ±5%, K: ±10%)

Resistance tolerance ±1% is also available for the following type.

10k ohm: NCP15XH103F0SRC

47k ohm: NCP15WB473F0SRC

100k ohm: NCP15WF104F0SRC

Standard Land Pattern Dimensions

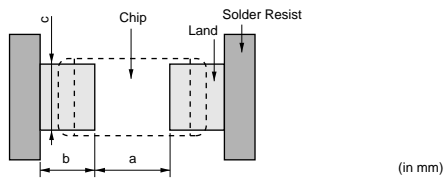

| Part Number | Soldering Methods | Dimensions (mm) | | | |
|--------------|-------------------|-----------------|---------|---------|---------|
| | | Chip (L×W) | a | b | c |
| NCP15 | Reflow Soldering | 1.0×0.5 | 0.4 | 0.4-0.5 | 0.5 |
| NCP18 | Flow Soldering | 1.6×0.8 | 0.6-1.0 | 0.8-0.9 | 0.6-0.8 |
| | Reflow Soldering | | 0.6-0.8 | 0.6-0.7 | 0.6-0.8 |
| NCM21 | Flow Soldering | 2.0×1.25 | 1.0-1.1 | 0.9-1.0 | 1.0-1.2 |
| | Reflow Soldering | | 1.0-1.1 | 0.6-0.7 | 1.0-1.2 |

NTC/PTC Thermistors for Automotive



NTC Thermistor Chip Type 0603 (1608) Size

0402/0603 sized Chip NTC Thermistors have Ni barrier termination and provide excellent solderability and offer high stability in environment by unique inner construction.

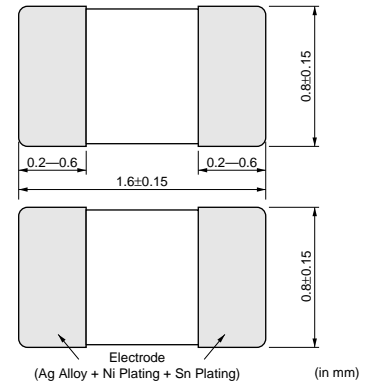

■ Features

1. Excellent solderability and high stability in environment
2. Excellent long time aging stability
3. High accuracy in resistance and B-constant
4. Flow/Reflow soldering possible
5. Lead is not contained in the product
6. NCP18 series are recognized by UL (UL1434, File No.E137188 Vol.2, Sec.2).

■ Applications

1. Car audio, car navigation
2. Various engine control units
3. Circuits for ETC equipment
4. Various motor driving circuits
5. Temperature compensation for various circuits

| Part Number | Resistance (25°C) | B-Constant (25-50°C) (K) | Permissible Operating Current (25°C) (mA) | Rated Electric Power (25°C) (mW) | Typical Dissipation Constant (25°C) (mW/°C) | Operating Temperature Range (°C) |
|-----------------|-------------------|--------------------------|---|----------------------------------|---|----------------------------------|
| NCP18XF101□0SRB | 100ohm | 3250 ±3% | 3.10 | 100 | 1.0 | -40 to 125 |
| NCP18XF151□0SRB | 150ohm | 3250 ±3% | 2.50 | 100 | 1.0 | -40 to 125 |
| NCP18XM221□0SRB | 220ohm | 3500 ±3% | 2.10 | 100 | 1.0 | -40 to 125 |
| NCP18XM331□0SRB | 330ohm | 3500 ±3% | 1.70 | 100 | 1.0 | -40 to 125 |
| NCP18XQ471□0SRB | 470ohm | 3650 ±2% | 1.40 | 100 | 1.0 | -40 to 125 |
| NCP18XQ681□0SRB | 680ohm | 3650 ±3% | 1.20 | 100 | 1.0 | -40 to 125 |
| NCP18XQ102□0SRB | 1.0k ohm | 3650 ±2% | 1.00 | 100 | 1.0 | -40 to 125 |
| NCP18XW152□0SRB | 1.5k ohm | 3950 ±3% | 0.81 | 100 | 1.0 | -40 to 125 |
| NCP18XW222□0SRB | 2.2k ohm | 3950 ±3% | 0.67 | 100 | 1.0 | -40 to 125 |
| NCP18XW332□0SRB | 3.3k ohm | 3950 ±3% | 0.55 | 100 | 1.0 | -40 to 125 |
| NCP18XM472□0SRB | 4.7k ohm | 3500 ±2% | 0.46 | 100 | 1.0 | -40 to 125 |
| NCP18XW682□0SRB | 6.8k ohm | 3950 ±3% | 0.38 | 100 | 1.0 | -40 to 125 |
| NCP18XH103□0SRB | 10k ohm | 3380 ±1% | 0.31 | 100 | 1.0 | -40 to 125 |
| NCP18XW153□0SRB | 15k ohm | 3950 ±3% | 0.25 | 100 | 1.0 | -40 to 125 |
| NCP18XW223□0SRB | 22k ohm | 3950 ±3% | 0.21 | 100 | 1.0 | -40 to 125 |
| NCP18WB333□0SRB | 33k ohm | 4050 ±3% | 0.17 | 100 | 1.0 | -40 to 125 |
| NCP18WB473□0SRB | 47k ohm | 4050 ±2% | 0.14 | 100 | 1.0 | -40 to 125 |
| NCP18WD683□0SRB | 68k ohm | 4150 ±3% | 0.12 | 100 | 1.0 | -40 to 125 |
| NCP18WF104□0SRB | 100k ohm | 4250 ±2% | 0.10 | 100 | 1.0 | -40 to 125 |
| NCP18WM154□0SRB | 150k ohm | 4500 ±3% | 0.08 | 100 | 1.0 | -40 to 125 |
| NCP18WM224□0SRB | 220k ohm | 4500 ±3% | 0.06 | 100 | 1.0 | -40 to 125 |
| NCP18WM474□0SRB | 470k ohm | 4500 ±3% | 0.04 | 100 | 1.0 | -40 to 125 |

A blank column is filled with resistance tolerance codes. (J: ±5%, K: ±10%)

Resistance tolerance ±1% is also available for the following type.

10k ohm: NCP18XH103F0SRB

47k ohm: NCP18WB473F1SRB

100k ohm: NCP18WF104F3SRB

■ Standard Land Pattern Dimensions

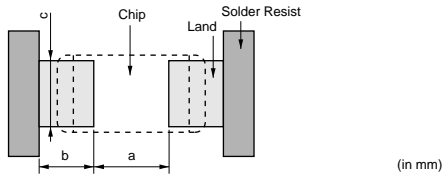

| Part Number | Soldering Methods | Dimensions (mm) | | | |
|--------------|-------------------|-----------------|---------|---------|---------|
| | | Chip (L×W) | a | b | c |
| NCP15 | Reflow Soldering | 1.0×0.5 | 0.4 | 0.4-0.5 | 0.5 |
| | Flow Soldering | | 0.6-1.0 | 0.8-0.9 | 0.6-0.8 |
| NCP18 | Reflow Soldering | 1.6×0.8 | 0.6-0.8 | 0.6-0.7 | 0.6-0.8 |
| | Flow Soldering | | 1.0-1.1 | 0.9-1.0 | 1.0-1.2 |
| NCM21 | Reflow Soldering | 2.0×1.25 | 1.0-1.1 | 0.6-0.7 | 1.0-1.2 |

2

NTC/PTC Thermistors for Automotive



NTC Thermistor Chip Type 0805 (2012) Size

0805 sized Chip NTC Thermistors have Ni barrier termination and offer high stability in environment by unique inner construction.

■ Features

1. High climate performance unique manufacturing method
2. Excellent long time aging stability
3. The performance of this product meets to AEC-Q200 (Automotive Electronics Council)
4. Lead is not contained in the product
5. High accuracy in resistance and B-constant
6. Flow/Reflow soldering possible

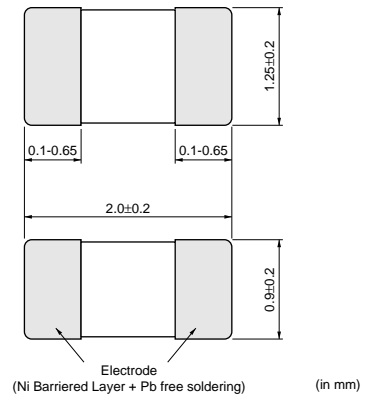

■ Applications

1. Car audio, car navigation
2. Various engine control units
3. Circuits for ETC equipment
4. Various motor driving circuits
5. Temperature compensation for various circuits

| Part Number | Resistance (25°C) (k ohm) | B-Constant (25-50°C) (K) | Permissible Operating Current (25°C) (mA) | Rated Electric Power (25°C) (mW) | Typical Dissipation Constant (25°C) (mW/°C) | Operating Temperature Range (°C) |
|------------------------|---------------------------|--------------------------|---|----------------------------------|---|----------------------------------|
| NCM21XQ103□0SRA | 10 | 3650 ±3% | 0.44 | 200 | 2.0 | -40 to 125 |
| NCM21XW223□0SRA | 22 | 3950 ±3% | 0.30 | 200 | 2.0 | -40 to 125 |
| NCM21WB473□0SRA | 47 | 4050 ±3% | 0.20 | 200 | 2.0 | -40 to 125 |
| NCM21WF104□0SRA | 100 | 4250 ±3% | 0.14 | 200 | 2.0 | -40 to 125 |

A blank column is filled with resistance tolerance codes. (J: ±5%, K: ±10%)

■ Standard Land Pattern Dimensions

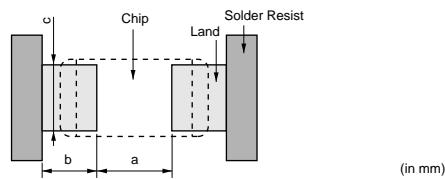

| Part Number | Soldering Methods | Dimensions (mm) | | | |
|------------------|-------------------|-----------------|---------|---------|---------|
| | | Chip (L×W) | a | b | c |
| NCP15 | Reflow Soldering | 1.0×0.5 | 0.4 | 0.4-0.5 | 0.5 |
| | Flow Soldering | 1.6×0.8 | 0.6-1.0 | 0.8-0.9 | 0.6-0.8 |
| Reflow Soldering | 0.6-0.8 | | 0.6-0.7 | 0.6-0.8 | |
| NCM21 | Flow Soldering | 2.0×1.25 | 1.0-1.1 | 0.9-1.0 | 1.0-1.2 |
| | Reflow Soldering | | 1.0-1.1 | 0.6-0.7 | 1.0-1.2 |

for NTC Thermistors Chip Type Temperature Characteristics (Center Value)

| Part Number | NCP□□XC220 | NCP□□XC330 | NCP□□XC470 | NCP□□XC680 | NCP□□XF101 | NCP□□XF151 | NCP□□XM221 | NCP□□XM331 |
|-------------|----------------|----------------|----------------|----------------|----------------|----------------|----------------|----------------|
| Resistance | 22Ω | 33Ω | 47Ω | 68Ω | 100Ω | 150Ω | 220Ω | 330Ω |
| B-Constant | 3100K | 3100K | 3100K | 3100K | 3250K | 3250K | 3500K | 3500K |
| Temp. (°C) | Resistance (Ω) | Resistance (Ω) | Resistance (Ω) | Resistance (Ω) | Resistance (Ω) | Resistance (Ω) | Resistance (Ω) | Resistance (Ω) |
| -40 | 355.823 | 533.734 | 760.166 | 1099.815 | 1824.175 | 2736.262 | 4947.904 | 7421.856 |
| -35 | 273.975 | 410.962 | 585.310 | 846.832 | 1390.685 | 2086.028 | 3703.755 | 5555.632 |
| -30 | 213.003 | 319.504 | 455.051 | 658.372 | 1070.653 | 1605.979 | 2798.873 | 4198.309 |
| -25 | 166.943 | 250.415 | 356.652 | 516.007 | 831.138 | 1246.708 | 2135.887 | 3203.831 |
| -20 | 131.997 | 197.996 | 281.994 | 407.991 | 650.960 | 976.440 | 1645.037 | 2467.555 |
| -15 | 105.318 | 157.978 | 224.998 | 325.529 | 514.441 | 771.661 | 1278.034 | 1917.051 |
| -10 | 84.670 | 127.005 | 180.886 | 261.707 | 409.700 | 614.550 | 1000.620 | 1500.930 |
| -5 | 68.628 | 102.942 | 146.614 | 212.123 | 328.877 | 493.315 | 789.612 | 1184.418 |
| 0 | 55.981 | 83.972 | 119.596 | 173.033 | 265.759 | 398.639 | 627.752 | 941.628 |
| 5 | 45.859 | 68.789 | 97.972 | 141.747 | 215.785 | 323.677 | 502.474 | 753.711 |
| 10 | 37.819 | 56.728 | 80.794 | 116.894 | 176.395 | 264.592 | 405.010 | 607.514 |
| 15 | 31.396 | 47.094 | 67.073 | 97.042 | 145.161 | 217.742 | 328.480 | 492.720 |
| 20 | 26.211 | 39.317 | 55.997 | 81.016 | 120.152 | 180.228 | 268.044 | 402.066 |
| 25 | 22.000 | 33.000 | 47.000 | 68.000 | 100.000 | 150.000 | 220.000 | 330.000 |
| 30 | 18.560 | 27.840 | 39.651 | 57.368 | 83.669 | 125.503 | 181.576 | 272.365 |
| 35 | 15.735 | 23.603 | 33.616 | 48.636 | 70.361 | 105.541 | 150.668 | 226.002 |
| 40 | 13.403 | 20.104 | 28.633 | 41.426 | 59.456 | 89.184 | 125.681 | 188.521 |
| 45 | 11.462 | 17.193 | 24.487 | 35.428 | 50.470 | 75.705 | 105.336 | 158.004 |
| 50 | 9.842 | 14.763 | 21.026 | 30.421 | 43.029 | 64.543 | 88.717 | 133.076 |
| 55 | 8.488 | 12.732 | 18.133 | 26.235 | 36.830 | 55.246 | 75.059 | 112.588 |
| 60 | 7.348 | 11.022 | 15.698 | 22.712 | 31.649 | 47.473 | 63.777 | 95.666 |
| 65 | 6.399 | 9.598 | 13.670 | 19.778 | 27.364 | 41.045 | 54.415 | 81.622 |
| 70 | 5.595 | 8.392 | 11.952 | 17.293 | 23.756 | 35.634 | 46.631 | 69.946 |
| 75 | 4.896 | 7.345 | 10.461 | 15.134 | 20.651 | 30.976 | 40.115 | 60.172 |
| 80 | 4.299 | 6.448 | 9.184 | 13.288 | 18.011 | 27.016 | 34.637 | 51.955 |
| 85 | 3.795 | 5.692 | 8.107 | 11.729 | 15.800 | 23.700 | 30.013 | 45.019 |
| 90 | 3.360 | 5.040 | 7.179 | 10.386 | 13.908 | 20.862 | 26.110 | 39.165 |
| 95 | 2.983 | 4.474 | 6.373 | 9.220 | 12.263 | 18.394 | 22.790 | 34.186 |
| 100 | 2.656 | 3.983 | 5.673 | 8.208 | 10.844 | 16.265 | 19.957 | 29.935 |
| 105 | 2.367 | 3.551 | 5.057 | 7.317 | 9.622 | 14.434 | 17.541 | 26.312 |
| 110 | 2.116 | 3.173 | 4.520 | 6.539 | 8.563 | 12.844 | 15.453 | 23.180 |
| 115 | 1.901 | 2.851 | 4.060 | 5.874 | 7.648 | 11.472 | 13.663 | 20.494 |
| 120 | 1.712 | 2.568 | 3.657 | 5.291 | 6.850 | 10.275 | 12.114 | 18.171 |
| 125 | 1.543 | 2.314 | 3.296 | 4.768 | 6.162 | 9.243 | 10.778 | 16.168 |

| Part Number | NCP□□XQ471 | NCP□□XQ681 | NCP□□XQ102 | NCP□□XW152 | NCP□□XW222 | NCP□□XW332 | NCP□□XM472 | NCP□□XW682 |
|-------------|----------------|----------------|-----------------|-----------------|-----------------|-----------------|-----------------|-----------------|
| Resistance | 470Ω | 680Ω | 1.0kΩ | 1.5kΩ | 2.2kΩ | 3.3kΩ | 4.7kΩ | 6.8kΩ |
| B-Constant | 3650K | 3650K | 3650K | 3950K | 3950K | 3950K | 3500K | 3950K |
| Temp. (°C) | Resistance (Ω) | Resistance (Ω) | Resistance (kΩ) | Resistance (kΩ) | Resistance (kΩ) | Resistance (kΩ) | Resistance (kΩ) | Resistance (kΩ) |
| -40 | 11822.473 | 17104.854 | 25.154 | 51.791 | 75.961 | 113.941 | 105.705 | 234.787 |
| -35 | 8767.745 | 12685.248 | 18.655 | 37.172 | 54.520 | 81.779 | 79.126 | 168.515 |
| -30 | 6570.224 | 9505.855 | 13.979 | 27.005 | 39.607 | 59.411 | 59.794 | 122.422 |
| -25 | 4971.784 | 7193.219 | 10.578 | 19.843 | 29.103 | 43.654 | 45.630 | 89.953 |
| -20 | 3796.933 | 5493.436 | 8.079 | 14.728 | 21.601 | 32.401 | 35.144 | 66.766 |
| -15 | 2923.400 | 4229.599 | 6.220 | 11.044 | 16.198 | 24.297 | 27.303 | 50.066 |
| -10 | 2269.599 | 3283.675 | 4.829 | 8.362 | 12.264 | 18.396 | 21.377 | 37.906 |
| -5 | 1775.225 | 2568.411 | 3.777 | 6.389 | 9.370 | 14.055 | 16.869 | 28.963 |
| 0 | 1399.050 | 2024.158 | 2.977 | 4.922 | 7.219 | 10.829 | 13.411 | 22.313 |
| 5 | 1110.220 | 1606.275 | 2.362 | 3.825 | 5.609 | 8.414 | 10.735 | 17.338 |
| 10 | 887.257 | 1283.691 | 1.888 | 2.994 | 4.391 | 6.586 | 8.653 | 13.571 |
| 15 | 713.463 | 1032.245 | 1.518 | 2.361 | 3.463 | 5.195 | 7.018 | 10.705 |
| 20 | 577.375 | 835.351 | 1.229 | 1.876 | 2.751 | 4.126 | 5.726 | 8.503 |
| 25 | 470.000 | 680.000 | 1.000 | 1.500 | 2.200 | 3.300 | 4.700 | 6.800 |
| 30 | 384.800 | 556.733 | 0.819 | 1.207 | 1.771 | 2.656 | 3.879 | 5.474 |
| 35 | 316.757 | 458.287 | 0.674 | 0.978 | 1.434 | 2.152 | 3.219 | 4.434 |
| 40 | 262.177 | 379.320 | 0.558 | 0.797 | 1.169 | 1.753 | 2.685 | 3.613 |
| 45 | 218.069 | 315.504 | 0.464 | 0.653 | 0.958 | 1.437 | 2.250 | 2.961 |
| 50 | 182.297 | 263.749 | 0.388 | 0.538 | 0.789 | 1.184 | 1.895 | 2.440 |
| 55 | 153.150 | 221.579 | 0.326 | 0.446 | 0.654 | 0.981 | 1.604 | 2.022 |
| 60 | 129.249 | 186.998 | 0.275 | 0.371 | 0.545 | 0.817 | 1.363 | 1.683 |
| 65 | 109.551 | 158.499 | 0.233 | 0.311 | 0.456 | 0.684 | 1.163 | 1.409 |
| 70 | 93.281 | 134.960 | 0.199 | 0.261 | 0.383 | 0.575 | 0.996 | 1.185 |
| 75 | 79.750 | 115.383 | 0.170 | 0.221 | 0.324 | 0.486 | 0.857 | 1.001 |
| 80 | 68.446 | 99.029 | 0.146 | 0.187 | 0.275 | 0.412 | 0.740 | 0.849 |
| 85 | 58.996 | 85.356 | 0.126 | 0.160 | 0.234 | 0.351 | 0.641 | 0.724 |
| 90 | 51.036 | 73.839 | 0.109 | 0.137 | 0.200 | 0.301 | 0.558 | 0.620 |
| 95 | 44.332 | 64.140 | 0.094 | 0.117 | 0.172 | 0.258 | 0.487 | 0.532 |
| 100 | 38.640 | 55.905 | 0.082 | 0.101 | 0.149 | 0.223 | 0.426 | 0.459 |
| 105 | 33.790 | 48.888 | 0.072 | 0.088 | 0.129 | 0.193 | 0.375 | 0.398 |
| 110 | 29.664 | 42.918 | 0.063 | 0.076 | 0.112 | 0.168 | 0.330 | 0.346 |
| 115 | 26.123 | 37.795 | 0.056 | 0.067 | 0.098 | 0.146 | 0.292 | 0.302 |
| 120 | 23.091 | 33.409 | 0.049 | 0.058 | 0.085 | 0.128 | 0.259 | 0.264 |
| 125 | 20.472 | 29.618 | 0.044 | 0.051 | 0.075 | 0.113 | 0.230 | 0.232 |

Continued on the following page.

for NTC Thermistors Chip Type Temperature Characteristics (Center Value)

↳ Continued from the preceding page.

| Part Number | NCP□□XH103 | NCP□□XV103 | NCM□□XQ103 | NCP□□XW153 | NCP□□XW223 | NCM□□XW223 | NCP□□WL223 | NCP□□WB333 |
|-------------|-----------------|-----------------|-----------------|-----------------|-----------------|-----------------|-----------------|-----------------|
| Resistance | 10kΩ | 10kΩ | 10kΩ | 15kΩ | 22kΩ | 22kΩ | 22kΩ | 33kΩ |
| B-Constant | 3380K | 3900K | 3650K | 3950K | 3950K | 3950K | 4485K | 4050K |
| Temp. (°C) | Resistance (kΩ) | Resistance (kΩ) | Resistance (kΩ) | Resistance (kΩ) | Resistance (kΩ) | Resistance (kΩ) | Resistance (kΩ) | Resistance (kΩ) |
| -40 | 195.652 | 328.996 | 251.542 | 517.912 | 759.605 | 759.605 | 1073.436 | 1227.263 |
| -35 | 148.171 | 237.387 | 186.548 | 371.724 | 545.196 | 545.196 | 753.900 | 874.449 |
| -30 | 113.347 | 173.185 | 139.792 | 270.048 | 396.070 | 396.070 | 535.073 | 630.851 |
| -25 | 87.559 | 127.773 | 105.783 | 198.426 | 291.025 | 291.025 | 383.590 | 460.457 |
| -20 | 68.237 | 95.327 | 80.786 | 147.278 | 216.008 | 216.008 | 277.643 | 339.797 |
| -15 | 53.650 | 71.746 | 62.200 | 110.439 | 161.977 | 161.977 | 202.813 | 253.363 |
| -10 | 42.506 | 54.564 | 48.289 | 83.617 | 122.638 | 122.638 | 149.462 | 190.766 |
| -5 | 33.892 | 41.813 | 37.771 | 63.888 | 93.702 | 93.702 | 111.082 | 144.964 |
| 0 | 27.219 | 32.330 | 29.767 | 49.221 | 72.191 | 72.191 | 83.233 | 111.087 |
| 5 | 22.021 | 25.194 | 23.622 | 38.245 | 56.093 | 56.093 | 62.858 | 85.842 |
| 10 | 17.926 | 19.785 | 18.878 | 29.936 | 43.907 | 43.907 | 47.831 | 66.861 |
| 15 | 14.674 | 15.651 | 15.180 | 23.613 | 34.633 | 34.633 | 36.664 | 52.470 |
| 20 | 12.081 | 12.468 | 12.285 | 18.756 | 27.509 | 27.509 | 28.304 | 41.471 |
| 25 | 10.000 | 10.000 | 10.000 | 15.000 | 22.000 | 22.000 | 22.000 | 33.000 |
| 30 | 8.315 | 8.072 | 8.187 | 12.074 | 17.709 | 17.709 | 17.214 | 26.430 |
| 35 | 6.948 | 6.556 | 6.740 | 9.780 | 14.344 | 14.344 | 13.557 | 21.298 |
| 40 | 5.834 | 5.356 | 5.578 | 7.969 | 11.688 | 11.688 | 10.744 | 17.266 |
| 45 | 4.917 | 4.401 | 4.640 | 6.531 | 9.578 | 9.578 | 8.566 | 14.076 |
| 50 | 4.161 | 3.635 | 3.879 | 5.382 | 7.894 | 7.894 | 6.871 | 11.538 |
| 55 | 3.535 | 3.019 | 3.259 | 4.459 | 6.540 | 6.540 | 5.543 | 9.506 |
| 60 | 3.014 | 2.521 | 2.750 | 3.713 | 5.446 | 5.446 | 4.497 | 7.870 |
| 65 | 2.586 | 2.115 | 2.331 | 3.108 | 4.559 | 4.559 | 3.669 | 6.549 |
| 70 | 2.228 | 1.781 | 1.985 | 2.613 | 3.832 | 3.832 | 3.009 | 5.475 |
| 75 | 1.925 | 1.509 | 1.697 | 2.208 | 3.239 | 3.239 | 2.481 | 4.595 |
| 80 | 1.669 | 1.284 | 1.456 | 1.873 | 2.748 | 2.748 | 2.056 | 3.874 |
| 85 | 1.452 | 1.097 | 1.255 | 1.597 | 2.342 | 2.342 | 1.713 | 3.282 |
| 90 | 1.268 | 0.941 | 1.086 | 1.367 | 2.004 | 2.004 | 1.434 | 2.789 |
| 95 | 1.110 | 0.810 | 0.943 | 1.174 | 1.722 | 1.722 | 1.206 | 2.379 |
| 100 | 0.974 | 0.701 | 0.822 | 1.013 | 1.486 | 1.486 | 1.019 | 2.038 |
| 105 | 0.858 | 0.608 | 0.719 | 0.878 | 1.287 | 1.287 | 0.866 | 1.751 |
| 110 | 0.758 | 0.530 | 0.631 | 0.763 | 1.119 | 1.119 | 0.739 | 1.509 |
| 115 | 0.672 | 0.463 | 0.556 | 0.665 | 0.975 | 0.975 | 0.633 | 1.306 |
| 120 | 0.596 | 0.406 | 0.491 | 0.582 | 0.854 | 0.854 | 0.545 | 1.134 |
| 125 | 0.531 | 0.358 | 0.436 | 0.511 | 0.750 | 0.750 | 0.471 | 0.987 |

| Part Number | NCP□□WL333 | NCP□□WB473 | NCM□□WB473 | NCP□□WL473 | NCP□□WD683 | NCP□□WL683 | NCP□□WF104 | NCM□□WF104 |
|-------------|-----------------|-----------------|-----------------|-----------------|-----------------|-----------------|-----------------|-----------------|
| Resistance | 33kΩ | 47kΩ | 47kΩ | 47kΩ | 68kΩ | 68kΩ | 100kΩ | 100kΩ |
| B-Constant | 4485K | 4050K | 4050K | 4485K | 4150K | 4485K | 4250K * | 4250K * |
| Temp. (°C) | Resistance (kΩ) | Resistance (kΩ) | Resistance (kΩ) | Resistance (kΩ) | Resistance (kΩ) | Resistance (kΩ) | Resistance (kΩ) | Resistance (kΩ) |
| -40 | 1610.154 | 1747.920 | 1747.920 | 2293.249 | 2735.359 | 2735.359 | 3317.893 | 4397.119 |
| -35 | 1130.850 | 1245.428 | 1245.428 | 1610.605 | 1937.391 | 1937.391 | 2330.237 | 3088.599 |
| -30 | 802.609 | 898.485 | 898.485 | 1143.110 | 1389.345 | 1389.345 | 1653.862 | 2197.225 |
| -25 | 575.385 | 655.802 | 655.802 | 819.487 | 1008.014 | 1008.014 | 1185.641 | 1581.881 |
| -20 | 416.464 | 483.954 | 483.954 | 593.146 | 738.978 | 738.978 | 858.168 | 1151.037 |
| -15 | 304.219 | 360.850 | 360.850 | 433.281 | 547.456 | 547.456 | 626.875 | 846.579 |
| -10 | 224.193 | 271.697 | 271.697 | 319.305 | 409.600 | 409.600 | 461.974 | 628.988 |
| -5 | 166.623 | 206.463 | 206.463 | 237.312 | 309.217 | 309.217 | 343.345 | 471.632 |
| 0 | 124.850 | 158.214 | 158.214 | 177.816 | 235.606 | 235.606 | 257.266 | 357.012 |
| 5 | 94.287 | 122.259 | 122.259 | 134.287 | 180.980 | 180.980 | 194.287 | 272.500 |
| 10 | 71.747 | 95.227 | 95.227 | 102.184 | 140.139 | 140.139 | 147.841 | 209.710 |
| 15 | 54.996 | 74.730 | 74.730 | 78.327 | 109.344 | 109.344 | 113.325 | 162.651 |
| 20 | 42.455 | 59.065 | 59.065 | 60.467 | 85.929 | 85.929 | 87.484 | 127.080 |
| 25 | 33.000 | 47.000 | 47.000 | 47.000 | 68.000 | 68.000 | 68.000 | 100.000 |
| 30 | 25.822 | 37.643 | 37.643 | 36.776 | 54.167 | 54.167 | 53.208 | 79.222 |
| 35 | 20.335 | 30.334 | 30.334 | 28.962 | 43.421 | 43.421 | 41.903 | 63.167 |
| 40 | 16.115 | 24.591 | 24.591 | 22.952 | 35.016 | 35.016 | 33.208 | 50.677 |
| 45 | 12.849 | 20.048 | 20.048 | 18.301 | 28.406 | 28.406 | 26.477 | 40.904 |
| 50 | 10.306 | 16.433 | 16.433 | 14.679 | 23.166 | 23.166 | 21.237 | 33.195 |
| 55 | 8.314 | 13.539 | 13.539 | 11.842 | 18.997 | 18.997 | 17.133 | 27.091 |
| 60 | 6.746 | 11.209 | 11.209 | 9.607 | 15.657 | 15.657 | 13.900 | 22.224 |
| 65 | 5.503 | 9.328 | 9.328 | 7.837 | 12.967 | 12.967 | 11.339 | 18.323 |
| 70 | 4.513 | 7.798 | 7.798 | 6.428 | 10.794 | 10.794 | 9.300 | 15.184 |
| 75 | 3.721 | 6.544 | 6.544 | 5.300 | 9.021 | 9.021 | 7.668 | 12.635 |
| 80 | 3.084 | 5.518 | 5.518 | 4.393 | 7.575 | 7.575 | 6.356 | 10.566 |
| 85 | 2.569 | 4.674 | 4.674 | 3.659 | 6.387 | 6.387 | 5.294 | 8.873 |
| 90 | 2.151 | 3.972 | 3.972 | 3.063 | 5.407 | 5.407 | 4.432 | 7.481 |
| 95 | 1.809 | 3.388 | 3.388 | 2.577 | 4.598 | 4.598 | 3.728 | 6.337 |
| 100 | 1.529 | 2.902 | 2.902 | 2.178 | 3.922 | 3.922 | 3.151 | 5.384 |
| 105 | 1.299 | 2.494 | 2.494 | 1.849 | 3.359 | 3.359 | 2.676 | 4.594 |
| 110 | 1.108 | 2.150 | 2.150 | 1.578 | 2.887 | 2.887 | 2.283 | 3.934 |
| 115 | 0.949 | 1.860 | 1.860 | 1.352 | 2.489 | 2.489 | 1.956 | 3.380 |
| 120 | 0.817 | 1.615 | 1.615 | 1.164 | 2.155 | 2.155 | 1.684 | 2.916 |
| 125 | 0.707 | 1.406 | 1.406 | 1.006 | 1.870 | 1.870 | 1.456 | 2.522 |

* B-Constant of NCP18WF104F1SRB is 4200K. Please contact us for the detail data.

for NTC Thermistors Chip Type Temperature Characteristics (Center Value)

Continued from the preceding page.

| Part Number | NCP□□WL104 | NCP□□WL154 | NCP□□WM154 | NCP□□WM224 | NCP□□WM474 |
|-------------|-----------------|-----------------|-----------------|-----------------|-----------------|
| Resistance | 100kΩ | 150kΩ | 150kΩ | 220kΩ | 470kΩ |
| B-Constant | 4485K | 4485K | 4500K | 4485K | 4500K |
| Temp. (°C) | Resistance (kΩ) | Resistance (kΩ) | Resistance (kΩ) | Resistance (kΩ) | Resistance (kΩ) |
| -40 | 4879.254 | 7318.881 | 7899.466 | 11585.884 | 24751.661 |
| -35 | 3426.818 | 5140.228 | 5466.118 | 8016.973 | 17127.169 |
| -30 | 2432.149 | 3648.224 | 3834.499 | 5623.931 | 12014.762 |
| -25 | 1743.590 | 2615.385 | 2720.523 | 3990.100 | 8524.305 |
| -20 | 1262.012 | 1893.018 | 1951.216 | 2861.784 | 6113.811 |
| -15 | 921.875 | 1382.813 | 1415.565 | 2076.162 | 4435.437 |
| -10 | 679.373 | 1019.059 | 1036.984 | 1520.909 | 3249.216 |
| -5 | 504.919 | 757.379 | 767.079 | 1125.049 | 2403.515 |
| 0 | 378.333 | 567.499 | 572.667 | 839.912 | 1794.358 |
| 5 | 285.717 | 428.575 | 431.264 | 632.521 | 1351.294 |
| 10 | 217.414 | 326.121 | 327.405 | 480.194 | 1025.870 |
| 15 | 166.654 | 249.981 | 250.538 | 367.455 | 785.018 |
| 20 | 128.653 | 192.979 | 193.166 | 283.310 | 605.252 |
| 25 | 100.000 | 150.000 | 150.000 | 220.000 | 470.000 |
| 30 | 78.247 | 117.370 | 117.281 | 172.012 | 367.480 |
| 35 | 61.622 | 92.433 | 92.293 | 135.364 | 289.186 |
| 40 | 48.835 | 73.252 | 73.090 | 107.198 | 229.014 |
| 45 | 38.937 | 58.406 | 58.240 | 85.419 | 182.485 |
| 50 | 31.231 | 46.846 | 46.665 | 68.441 | 146.215 |
| 55 | 25.195 | 37.793 | 37.605 | 55.153 | 117.828 |
| 60 | 20.441 | 30.661 | 30.453 | 44.665 | 95.420 |
| 65 | 16.675 | 25.013 | 24.804 | 36.379 | 77.718 |
| 70 | 13.677 | 20.516 | 20.293 | 29.763 | 63.584 |
| 75 | 11.277 | 16.916 | 16.679 | 24.462 | 52.260 |
| 80 | 9.346 | 14.019 | 13.776 | 20.205 | 43.166 |
| 85 | 7.785 | 11.678 | 11.428 | 16.761 | 35.808 |
| 90 | 6.517 | 9.776 | 9.520 | 13.962 | 29.828 |
| 95 | 5.482 | 8.223 | 7.966 | 11.684 | 24.961 |
| 100 | 4.634 | 6.951 | 6.688 | 9.809 | 20.955 |
| 105 | 3.935 | 5.902 | 5.639 | 8.270 | 17.668 |
| 110 | 3.357 | 5.035 | 4.772 | 6.998 | 14.951 |
| 115 | 2.877 | 4.315 | 4.052 | 5.942 | 12.695 |
| 120 | 2.476 | 3.714 | 3.454 | 5.067 | 10.824 |
| 125 | 2.141 | 3.211 | 2.955 | 4.334 | 9.259 |

for NTC Thermistors Chip Type Specifications and Test Methods

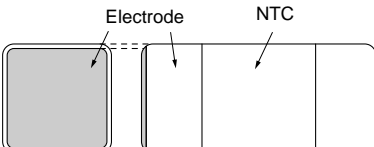
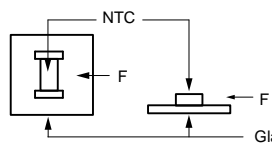
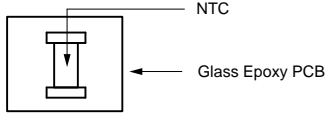
| No. | Item | Rating Value | Method of Examination | | | | | | | | | |
|-------|---|--|--|--------------|------------|---|-------|-----------|---|---|------------|----|
| 1 | Dry Heat 1 | <ul style="list-style-type: none"> Resistance (R25) change should be less than $\pm 10\%$ B-constant (B25/50) change should be less than $\pm 2\%$ No visible damage | 150 \pm 3°C in air, for 500 +48/-0 hrs. without loading | | | | | | | | | |
| 2 | Dry Heat 2 | <ul style="list-style-type: none"> Resistance (R25) change should be less than $\pm 5\%$ B-constant (B25/50) change should be less than $\pm 2\%$ No visible damage | 125 \pm 3°C in air, for 1000 +48/-0 hrs. without loading | | | | | | | | | |
| 3 | Cold | | -40 \pm 3°C in air, for 1000 +48/-0 hrs. without loading | | | | | | | | | |
| 4 | Damp Heat | | 60 \pm 2°C, 90-95%RH in air, for 1000 +48/-0 hrs. without loading | | | | | | | | | |
| 5 | High Temperature Load | | 85 \pm 2°C in air, with Permissive Operating Current for 1000 +48/-0 hrs. | | | | | | | | | |
| 6 | Thermal Shock | <ul style="list-style-type: none"> Resistance (R25) change should be less than $\pm 10\%$ B-constant (B25/50) change should be less than $\pm 2\%$ No visible damage | 1000 cycles of following sequence <table border="1" style="margin-left: 20px;"> <thead> <tr> <th>Step</th> <th>Temp. (°C)</th> <th>Time (min.)</th> </tr> </thead> <tbody> <tr> <td>1</td> <td>-55 +0/-3</td> <td>30</td> </tr> <tr> <td>2</td> <td>+125 +3/-0</td> <td>30</td> </tr> </tbody> </table> | Step | Temp. (°C) | Time (min.) | 1 | -55 +0/-3 | 30 | 2 | +125 +3/-0 | 30 |
| Step | Temp. (°C) | Time (min.) | | | | | | | | | | |
| 1 | -55 +0/-3 | 30 | | | | | | | | | | |
| 2 | +125 +3/-0 | 30 | | | | | | | | | | |
| 7 | High Temperature Humidity Load | | 85 \pm 2°C, 85%RH in air, with Permissive Operating Current for 1000 +48/-0 hrs. | | | | | | | | | |
| 8 | Solderability | <table border="1" style="margin-left: 20px;"> <thead> <tr> <th>P/N</th> <th>Rating value</th> </tr> </thead> <tbody> <tr> <td>NCP15</td> <td rowspan="2">Minimum 95% of the whole electrode surface should be covered with solder.</td> </tr> <tr> <td>NCP18</td> </tr> <tr> <td>NCM21</td> <td>Minimum 75% of the whole electrode surface should be covered with solder.</td> </tr> </tbody> </table> | P/N | Rating value | NCP15 | Minimum 95% of the whole electrode surface should be covered with solder. | NCP18 | NCM21 | Minimum 75% of the whole electrode surface should be covered with solder. | Soldering Temp.: 235 \pm 5°C Solder: Sn60%/Pb40% Immersion Time: 2 \pm 0.5 sec. NTC Thermistor should be immersed completely under the solder meniscus | | |
| P/N | Rating value | | | | | | | | | | | |
| NCP15 | Minimum 95% of the whole electrode surface should be covered with solder. | | | | | | | | | | | |
| NCP18 | | | | | | | | | | | | |
| NCM21 | Minimum 75% of the whole electrode surface should be covered with solder. | | | | | | | | | | | |
| 9 | Soldering Heat Resistant | <ul style="list-style-type: none"> Resistance (R25) change should be less than $\pm 5\%$ B-constant (B25/50) change should be less than $\pm 2\%$ No visible damage Normal appearance on the section showed by slanting line parts of the electrodes on the figure.  | Soldering Temp.: 260 \pm 5°C Solder: Sn60%/Pb40% Immersion Time: 10 \pm 0.5 sec. NTC Thermistor should be immersed completely under the solder meniscus. Preheating Temp.: 150 \pm 5°C Preheating Time: 3 min. | | | | | | | | | |
| 10 | Robustness of Electrode | No peeling of the electrodes | Solder NTC Thermistor on the Glass Epoxy PCB, and apply force as shown below: <table border="1" style="margin-left: 20px;"> <thead> <tr> <th>P/N</th> <th>Force (F)</th> </tr> </thead> <tbody> <tr> <td>NCP15</td> <td>3.0N</td> </tr> <tr> <td>NCP18</td> <td>4.90N</td> </tr> <tr> <td>NCM21</td> <td>4.90N</td> </tr> </tbody> </table>  | P/N | Force (F) | NCP15 | 3.0N | NCP18 | 4.90N | NCM21 | 4.90N | |
| P/N | Force (F) | | | | | | | | | | | |
| NCP15 | 3.0N | | | | | | | | | | | |
| NCP18 | 4.90N | | | | | | | | | | | |
| NCM21 | 4.90N | | | | | | | | | | | |
| 11 | Vibration Resistant | <ul style="list-style-type: none"> Resistance (R25) change should be less than $\pm 5\%$ B-constant (B25/50) change should be less than $\pm 2\%$ No visible damage | Solder NTC Thermistor on the Glass Epoxy PCB as shown below. Frequency: 10-2000-10Hz (20 min.) Max. amplitude: 3.0mm Vibrated for a period of 4 hrs. in three (3) directions perpendicularly intersecting each other (for total of 12 hrs.).  | | | | | | | | | |

Continued on the following page.

for NTC Thermistors Chip Type Specifications and Test Methods

Continued from the preceding page.

| No. | Item | Rating Value | Method of Examination | | | | | | | | | | | | |
|-------|------------------------------------|---|--|-----|-----------------------|----------------------|-------|-----|-------------|-------|-----|-------------|-------|-----|-------------|
| 12 | Resistance to Bending of Substance | <ul style="list-style-type: none"> •Resistance (R25) change should be less than $\pm 5\%$ •B-constant (B25/50) change should be less than $\pm 2\%$ •No visible damage | <p>Solder NTC Thermistor on Test Board, and apply force on back side of Test Board as shown below: Bending Speed: 1.0mm/s, Hold Time : 5+/-1 sec. Board Material: Glass Epoxy</p> <table border="1"> <thead> <tr> <th>P/N</th> <th>Bending Strength (mm)</th> <th>Board Dimension (mm)</th> </tr> </thead> <tbody> <tr> <td>NCP15</td> <td>1.5</td> <td>100X40X0.8t</td> </tr> <tr> <td>NCP18</td> <td>1.5</td> <td>100X40X1.6t</td> </tr> <tr> <td>NCM21</td> <td>2.0</td> <td>100X40X1.6t</td> </tr> </tbody> </table> | P/N | Bending Strength (mm) | Board Dimension (mm) | NCP15 | 1.5 | 100X40X0.8t | NCP18 | 1.5 | 100X40X1.6t | NCM21 | 2.0 | 100X40X1.6t |
| P/N | Bending Strength (mm) | Board Dimension (mm) | | | | | | | | | | | | | |
| NCP15 | 1.5 | 100X40X0.8t | | | | | | | | | | | | | |
| NCP18 | 1.5 | 100X40X1.6t | | | | | | | | | | | | | |
| NCM21 | 2.0 | 100X40X1.6t | | | | | | | | | | | | | |

- NTC Thermistor shall be soldered on the glass epoxy PCB as shown below
 - Recommendable Land Dimensions
 - Recommendable Soldering Conditions
 - Recommendable Solder paste
- R25 means the zero-power resistance at 25°C.
- B25/50 is calculated by the zero-power resistances of NTC Thermistor at 25°C and at 50°C.
- After each test, NTC Thermistor should be kept for 1 hour at room temperature (normal humidity and normal atmospheric pressure). Then the resistances (R25 and R50) should be measured and the appearance should be visually examined.
- We are not to guarantee the Resistance (R25) change and B-constant (B25/50) change in Thermal Shock (No. 6) in case of defect of part for mounting.

for NTC Thermistors Chip Type ⚠Caution/Notice

■ ⚠Caution (Storage and Operating Condition)

This product is designed for application in an ordinary environment (normal room temperature, humidity and atmospheric pressure).

Do not use under the following conditions because all these factors can deteriorate the product characteristics or cause failures and burn-out.

1. Corrosive gas or deoxidizing gas
(Chlorine gas, Hydrogen sulfide gas, Ammonia gas, Sulfuric acid gas, Nitric oxide gas, etc.)

2. Volatile or flammable gas
3. Dusty conditions
4. Under vacuum, or under high or low-pressure
5. Wet or humid locations
6. Places with salt water, oils, chemical liquids or organic solvents
7. Strong vibrations
8. Other places where similar hazardous conditions exist

■ ⚠Caution (Other)

Be sure to provide an appropriate fail-safe function on your product to prevent secondary damages that may be caused by the abnormal function or the failure of our product.

■ Notice (Storage and Operating Condition)

To keep solderability of product from declining, the following storage condition is recommended.

1. Storage condition:
Temperature -10 to +40 degree C
Humidity less than 75%RH (not dewing condition)
2. Storage term:
Use this product within 6 months after delivery by first-in and first-out stocking system.

3. Handling after unpacking:
After unpacking, reseal product promptly or store it in a sealed container with a drying agent.
4. Storage place:
Do not store this product in corrosive gas (sulfuric acid gas, chlorine gas, etc.) or in direct sunlight.

■ Notice (Rating)

Use this product within the specified temperature range.

Higher temperature may cause deterioration of the characteristics or the material quality of this product.

for NTC Thermistors Chip Type ⚠️ Caution/Notice

■ Notice (Soldering and Mounting)

1. Mounting Position

Choose a mounting position that minimizes the stress imposed on the chip during flexing or bending of the board.

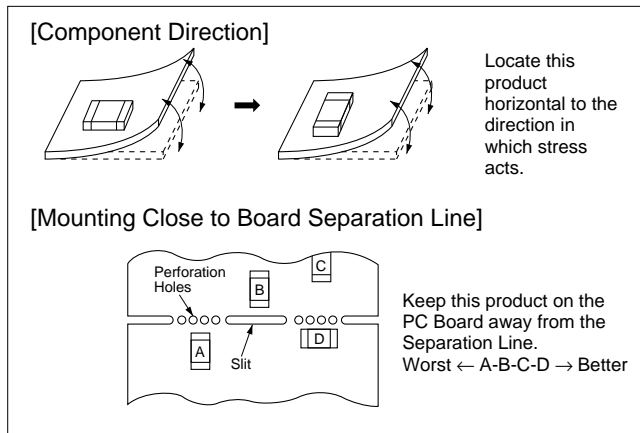

2. Reflow Soldering Conditions

Allowable Reflow Soldering Temperature and Time

(NCP15 Series)

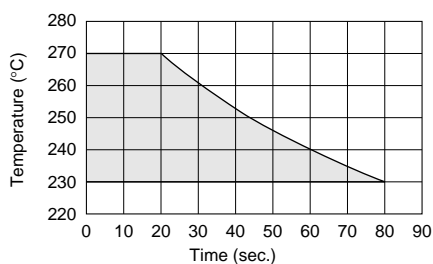

Standard Soldering Conditions

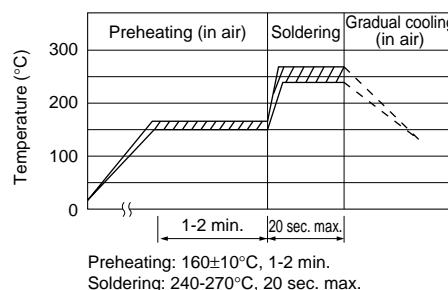

(NCP18 Series)

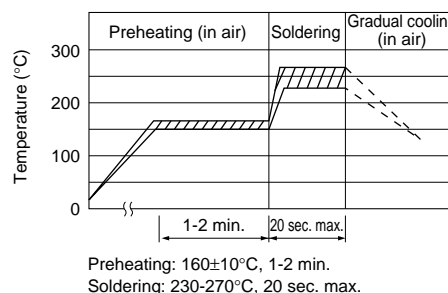
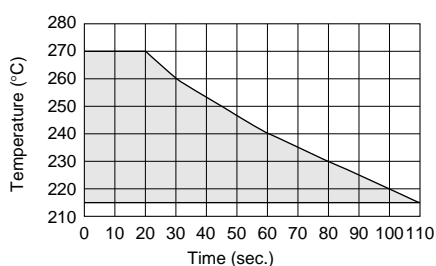

(NCM21 Series)

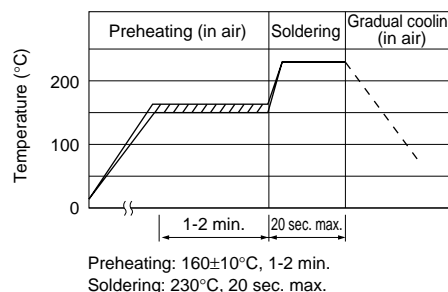
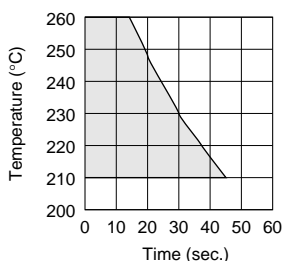

Continued on the following page. ↗

for NTC Thermistors Chip Type ⚠Caution/Notice

☐ Continued from the preceding page.

3. Flow Soldering Conditions

Allowable Reflow Soldering Temperature and Time

(NCP18 Series)

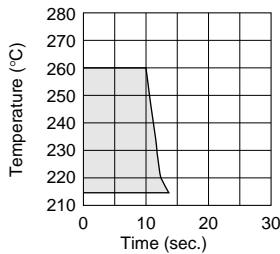

(NCM21 Series)

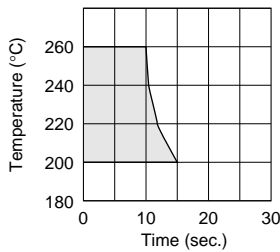

Standard Soldering Conditions

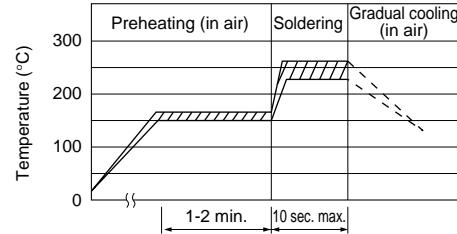

Preheating: 160±10°C, 1-2 min.
Soldering: 230-260°C, 10 sec. max.

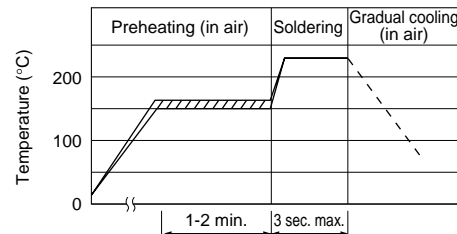

Preheating: 160±10°C, 1-2 min.
Soldering: 240°C, 3 sec. max.

4. Solder and Flux

(1) Solder and Paste

- (a) Reflow Soldering: NCP15/NCP18/NCM21 Series
Use RA/RMA type or equivalent type of solder paste.
For your reference, we are using the solder paste below for any internal tests of this product.
- RMA9086 90-4-M20 (Sn:Pb=63wt%:37wt%)
(Manufactured by Alpha Metals Japan Ltd.)
 - M705-221BM5-42-11
(Sn:Ag:Cu=96.5wt%:3.0wt%:0.5wt%)
(Manufactured by Senju Metal Industry Co., Ltd.)

(b) Flow Soldering: NCP18/NCM21 Series

- We are using the solder paste below for any internal tests of this product.
- Sn:Pb=63wt%:37wt%
 - Sn:Ag:Cu=96.5wt%:3.0wt%:0.5wt%

(2) Flux

- Use Rosin-based flux.
Do not use strong acidic flux (with halide content exceeding 0.2wt%)

5. Cleaning Conditions

For removing the flux after soldering, observe the following points in order to avoid deterioration of the characteristics or any change of the external electrodes' quality.

| | NCP15 | NCP18/NCM21 |
|----------------------------|---|---|
| Solvent | Isopropyl Alcohol | Isopropyl Alcohol |
| Dipping Cleaning | Less than 5 mins. at room temp. or less than 2 mins. at 40°C max. | Less than 5 mins. at room temp. or less than 2 mins. at 40°C max. |
| Ultrasonic Cleaning | Less than 5 mins. 20W/l Frequency of 28 to 40kHz. | Less than 1 min. 20W/l Frequency of several 10 to 100kHz. |

6. Drying

After cleaning, promptly dry this product.

Continued on the following page. ☐

for NTC Thermistors Chip Type ⚠️Caution/Notice

☒ Continued from the preceding page.

7. Printing Conditions of Solder Paste

- The amount of solder is critical. Standard height of fillet is shown in the table below.
- Too much soldering may cause mechanical stress, resulting in cracking, mechanical and/or electronic damage.

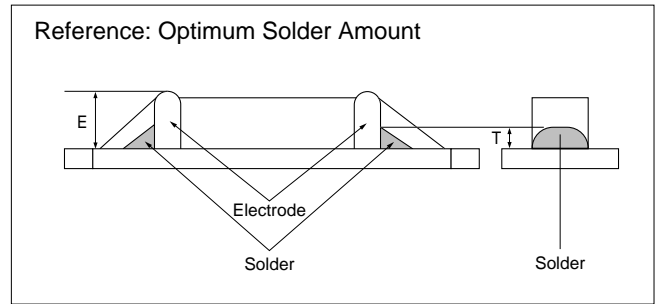

| Part Number | The Solder Paste Thickness | T |
|-------------|----------------------------|------------------------------|
| NCP15 | 100μm | $1/3E \leq T \leq E$ |
| NCP18 | 150μm | $0.2\text{mm} \leq T \leq E$ |
| NCM21 | 150-200μm | $0.2\text{mm} \leq T \leq E$ |

8. Adhesive Application and Curing

- Thin or insufficient adhesive may result in loose component contact with land during flow soldering.
- Low viscosity adhesive causes chips to slip after mounting.

■ Notice (Handling)

The ceramic of this product is fragile, and care must be taken not to load a excessive press-force or not to give a shock at handling.

Such forces may cause cracking or chipping.

NTC/PTC Thermistors for Automotive



NTC Thermistor Lead Type for Temperature Sensor

This product is a sensor type NTC Thermistor to be useful in the normal temperature range developed by the unique ceramic technology and the automatic assembly.

■ Features

1. High-accuracy of +/-1%
+/-1% of resistance and B-Constant tolerance is realized due to uniform thickness by the precise sheet forming method.
2. Quick response
This product provides faster response time due to its smaller size.
3. Taping type is available.
4. Strong lead strength
Original lead-wiring technique assures reliable connection. It can be formed and bent flexibly according to the mounting condition.

■ Applications

1. Car audio, car navigation
2. Various engine control unit
3. Circuits for ETC equipment
4. Various motor driving circuits
5. Temperature compensation for various circuits

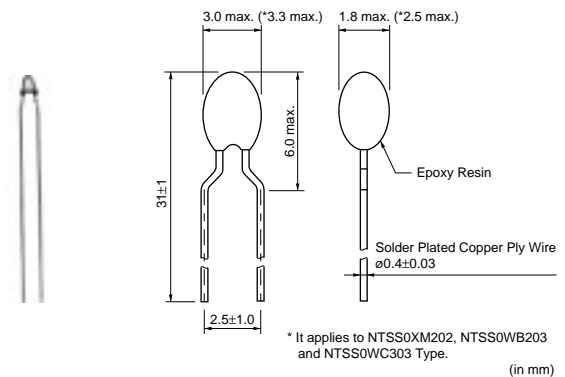

| Part Number | Resistance (25°C) (k ohm) | B-Constant (25-50°C) (K) | Permissible Operating Current (25°C) (mA) | Rated Electric Power (25°C) (mW) | Typical Dissipation Constant (25°C) (mW/°C) | Thermal Time Constant (25°C)(s) | Operating Temperature Range (°C) |
|-----------------|---------------------------|--------------------------|---|----------------------------------|---|---------------------------------|----------------------------------|
| NTSS0XM202□E1B0 | 2.0 | 3500 ±1% | 1.05 | 21 | 2.1 | 7 | -40 to 125 |
| NTSS0XR502□E1B0 | 5.0 | 3700 ±1% | 0.68 | 21 | 2.1 | 7 | -40 to 125 |
| NTSS0XH103□E1B0 | 10 | 3380 ±1% | 0.38 | 15 | 1.5 | 7 | -40 to 125 |
| NTSS0XV103□E1B0 | 10 | 3900 ±1% | 0.46 | 21 | 2.1 | 7 | -40 to 125 |
| NTSS0WB203□E1B0 | 20 | 4050 ±1% | 0.31 | 21 | 2.1 | 7 | -40 to 125 |
| NTSS0WC303□E1B0 | 30 | 4100 ±1% | 0.26 | 21 | 2.1 | 7 | -40 to 125 |
| NTSS0WD503□E1B0 | 50 | 4150 ±1% | 0.20 | 21 | 2.1 | 7 | -40 to 125 |
| NTSS0WF104□E1B0 | 100 | 4250 ±1% | 0.14 | 21 | 2.1 | 7 | -40 to 125 |

A blank column is filled with resistance tolerance codes. (F: ±1%, E: ±3%)
Taping type of part numbers with "N6A0" is available. (Lead spacing=5mm)

■ Temperature Tolerance-Temperature Characteristics

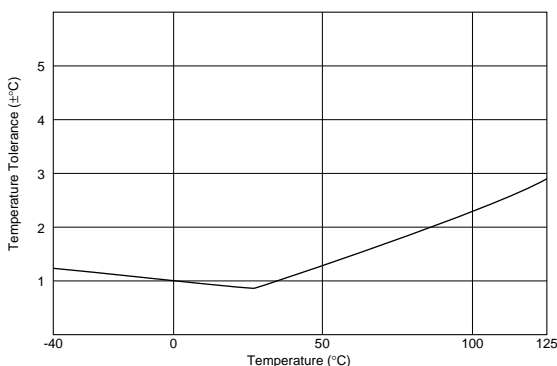

for NTC Thermistors Lead Type Temperature Characteristics (Center Value)

| Part Number | NTS□□XM202 | NTS□□XR502 | NTS□□XH103 | NTS□□XV103 | NTS□□WB203 | NTS□□WC303 | NTS□□WD503 | NTS□□WF104 |
|-------------|-----------------|-----------------|-----------------|-----------------|-----------------|-----------------|-----------------|-----------------|
| Resistance | 2.0kΩ | 5.0kΩ | 10kΩ | 10kΩ | 20kΩ | 30kΩ | 50kΩ | 100kΩ |
| B-Constant | 3500K | 3700K | 3380K | 3900K | 4050K | 4100K | 4150K | 4250K |
| Temp. (°C) | Resistance (kΩ) | Resistance (kΩ) | Resistance (kΩ) | Resistance (kΩ) | Resistance (kΩ) | Resistance (kΩ) | Resistance (kΩ) | Resistance (kΩ) |
| -40 | 44.657 | 123.484 | 195.652 | 347.808 | 733.007 | 1149.500 | 1948.575 | 4256.752 |
| -35 | 33.505 | 92.295 | 148.171 | 248.591 | 524.831 | 819.651 | 1387.289 | 3005.888 |
| -30 | 25.388 | 69.614 | 113.347 | 179.973 | 380.184 | 591.391 | 999.456 | 2148.514 |
| -25 | 19.402 | 52.860 | 87.559 | 131.832 | 277.845 | 430.529 | 728.895 | 1555.020 |
| -20 | 14.961 | 40.480 | 68.237 | 97.679 | 205.260 | 316.870 | 537.039 | 1137.312 |
| -15 | 11.644 | 31.275 | 53.650 | 73.119 | 153.642 | 236.337 | 399.167 | 839.314 |
| -10 | 9.133 | 24.339 | 42.506 | 55.301 | 116.016 | 177.842 | 299.469 | 625.338 |
| -5 | 7.198 | 19.154 | 33.892 | 42.257 | 88.125 | 134.630 | 226.186 | 469.127 |
| 0 | 5.716 | 15.148 | 27.219 | 32.582 | 67.522 | 102.816 | 172.393 | 355.224 |
| 5 | 4.571 | 11.964 | 22.021 | 25.324 | 52.168 | 79.183 | 132.857 | 272.045 |
| 10 | 3.682 | 9.520 | 17.926 | 19.847 | 40.617 | 61.460 | 103.089 | 209.803 |
| 15 | 2.987 | 7.624 | 14.674 | 15.679 | 31.847 | 48.045 | 80.430 | 162.713 |
| 20 | 2.437 | 6.160 | 12.081 | 12.478 | 25.151 | 37.834 | 63.201 | 127.117 |
| 25 | 2.000 | 5.000 | 10.000 | 10.000 | 20.000 | 30.000 | 50.000 | 100.000 |
| 30 | 1.651 | 4.082 | 8.315 | 8.068 | 16.014 | 23.955 | 39.825 | 79.215 |
| 35 | 1.371 | 3.354 | 6.948 | 6.552 | 12.902 | 19.249 | 31.918 | 63.150 |
| 40 | 1.143 | 2.773 | 5.834 | 5.353 | 10.457 | 15.560 | 25.733 | 50.649 |
| 45 | 0.958 | 2.299 | 4.917 | 4.399 | 8.527 | 12.657 | 20.877 | 40.885 |
| 50 | 0.807 | 1.914 | 4.161 | 3.635 | 6.993 | 10.354 | 17.034 | 33.195 |
| 55 | 0.683 | 1.607 | 3.535 | 3.020 | 5.771 | 8.525 | 13.929 | 27.014 |
| 60 | 0.582 | 1.356 | 3.014 | 2.521 | 4.789 | 7.058 | 11.439 | 22.079 |
| 65 | 0.497 | 1.149 | 2.586 | 2.115 | 3.992 | 5.869 | 9.485 | 18.226 |
| 70 | 0.426 | 0.978 | 2.228 | 1.783 | 3.343 | 4.905 | 7.906 | 15.124 |
| 75 | 0.367 | 0.834 | 1.925 | 1.510 | 2.809 | 4.113 | 6.614 | 2.598 |
| 80 | 0.318 | 0.714 | 1.669 | 1.284 | 2.371 | 3.463 | 5.558 | 10.542 |
| 85 | 0.276 | 0.612 | 1.452 | 1.096 | 2.020 | 2.945 | 4.686 | 8.852 |
| 90 | 0.240 | 0.527 | 1.268 | 0.939 | 1.729 | 2.516 | 3.967 | 7.463 |
| 95 | 0.210 | 0.456 | 1.110 | 0.808 | 1.476 | 2.143 | 3.373 | 6.321 |
| 100 | 0.183 | 0.396 | 0.974 | 0.698 | 1.264 | 1.832 | 2.878 | 5.374 |
| 105 | 0.161 | 0.345 | 0.858 | 0.605 | 1.085 | 1.571 | 2.465 | 4.585 |
| 110 | 0.142 | 0.302 | 0.758 | 0.527 | 0.935 | 1.350 | 2.118 | 3.925 |
| 115 | 0.125 | 0.264 | 0.671 | 0.460 | 0.812 | 1.171 | 1.828 | 3.376 |
| 120 | 0.111 | 0.232 | 0.596 | 0.403 | 0.708 | 1.019 | 1.583 | 2.913 |
| 125 | 0.099 | 0.205 | 0.531 | 0.354 | 0.617 | 0.886 | 1.374 | 2.520 |

4

for NTC Thermistors Lead Type Specifications and Test Methods

| No. | Item | Rating Value | Method of Examination |
|-----|---------------------------------|--|--|
| 1 | High Temp. Test 1 | <ul style="list-style-type: none"> Resistance (R25) fluctuation rate less than $\pm 2\%$ B-Constant (B25/50) fluctuation rate less than $\pm 1\%$ | 150 $\pm 2^\circ\text{C}$ in air, for 500 +48/-0 hrs. without loading |
| 2 | High Temp. Test 2 | | 125 $\pm 3^\circ\text{C}$ in air, for 1000 +48/-0 hrs. without loading |
| 3 | Low Temp. Test | <ul style="list-style-type: none"> Resistance (R25) fluctuation rate less than $\pm 1\%$ B-Constant (B25/50) fluctuation rate less than $\pm 1\%$ | -40 $\pm 3^\circ\text{C}$ in air, for 1000 +48/-0 hrs. without loading |
| 4 | Humidity Test | | 60 $\pm 2^\circ\text{C}$, 90-95%RH in air, for 1000 +48/-0 hrs. without loading |
| 5 | High Temp. Pressure Test | | 121 $\pm 2^\circ\text{C}$, 2atm. in saturated vapor, leave for 2 +1/-0 hrs. without loading |
| 6 | Heat Shock Test | <ul style="list-style-type: none"> Resistance (R25) fluctuation rate less than $\pm 2\%$ B-Constant (B25/50) fluctuation rate less than $\pm 1\%$ | -55 $\pm 3^\circ\text{C}$, 30 min. in air 125 $\pm 2^\circ\text{C}$, 30 min. in air (1 cycle) Continuous 1000 +4/-0 cycles without loading |
| 7 | High Temp. Continuous Load Test | | 100 $\pm 2^\circ\text{C}$ in air, with Permissive Operating Current for 1000 +48/-0 hrs. |
| 8 | Humid Continuous Load Test | | 85 $\pm 2^\circ\text{C}$, 85%RH in air, with Permissive Operating Current for 1000 +48/-0 hrs. |
| 9 | Insulation Break-down Voltage | <ul style="list-style-type: none"> Normal appearance Normal electrical characteristics on 500Vdc, 1 min. | 2mm length of coating resin from the top of thermistor is to be dipped into beads of lead (Pb), and D.C 500V is applied to circuit between beads of lead (Pb) and lead wire. |
| 10 | Solvent Proof | <ul style="list-style-type: none"> Normal appearance Resistance (R25) fluctuation rate less than $\pm 1\%$ B-Constant (B25/50) fluctuation rate less than $\pm 1\%$ | Using Chlorine Washing Solvents, Boiling, 10 min. Supersonic, 10 min. |
| 11 | Resistance to Soldering Heat | <ul style="list-style-type: none"> Resistance (R25) change less than $\pm 1\%$ B-Constant (B25/50) change less than $\pm 1\%$ | Both lead wires are immersed into 350 $\pm 10^\circ\text{C}$ solder for 3.5 ± 0.5 seconds or 260 $\pm 5^\circ\text{C}$ solder for 10 ± 1 seconds according to Fig-1. (solder <JIS Z 3282 H60A>) <div style="text-align: center;"> <p>Fig-1</p> </div> |
| 12 | Solderability | More than 90% of lead wire surface should be covered by solder. | Both lead wires are immersed into flux (25wt% colophony <JIS K 5902> isopropyl alcohol <JIS K 8839>) for 5-10 secs. Then both lead wires are immersed into 235 $\pm 5^\circ\text{C}$ solder <JIS Z 3282 H60A> for 2 ± 0.5 seconds. according to Fig-1. |
| 13 | Lead Wire Pull Strength | <ul style="list-style-type: none"> No visible damage Resistance (R25) change less than $\pm 1\%$ B-Constant (B25/50) change less than $\pm 1\%$ | One end of a lead wire should be fixed and 2.5N force for 10 seconds should be applied to the other lead wire as shown in Fig-2. <div style="text-align: center;"> <p>Fig-2</p> </div> |
| 14 | Lead Wire Bending Strength | No visible damage on lead wire | One lead wire is held and 2.5N force is applied. Then the body of NTC thermistor is bent 90° degrees and again bent back to the initial position. This sequence should be completed twice. See Fig-3. <div style="text-align: center;"> <p>Fig-3</p> </div> |
| 15 | Drop Test | | NTC Thermistor should be dropped without any force onto concrete floor from 1 meter height one time. |
| 16 | Vibration | <ul style="list-style-type: none"> No visible damage Resistance (R25) change less than $\pm 1\%$ B-Constant (B25/50) change less than $\pm 1\%$ | NTC Thermistor is to be fixed to the vibration test equipment. Frequency: 10-2000-10Hz (20 min.) Max amplitude: 3.0mm Vibrated for a period of 4 hrs. in 3 perpendicular directions each other (for total of 12 hrs.) |

* R25 is zero-power resistance of Thermistor in 25°C.

• After each test, NTC Thermistor should be kept for 1 hour at room temperature (normal humidity and normal atmospheric pressure). Then the resistances (R25 and R50) should be measured and the appearance should be visually examined.

for NTC Thermistors Lead Type ⚠Caution/Notice

■ ⚠Caution (Storage and Operating Condition)

This product is designed for application in an ordinary environment (normal room temperature, humidity and atmospheric pressure).

Do not use under the following conditions because all these factors can deteriorate the product characteristics or cause failures and burn-out.

1. Corrosive gas or deoxidizing gas
(Chlorine gas, Hydrogen sulfide gas, Ammonia gas, Sulfuric acid gas, Nitric oxide gas, etc.)

2. Volatile or flammable gas
3. Dusty conditions
4. Under vacuum, or under high or low-pressure
5. Wet or humid locations
6. Places with salt water, oils, chemical liquids or organic solvents
7. Strong vibrations
8. Other places where similar hazardous conditions exist

■ ⚠Caution (Other)

Be sure to provide an appropriate fail-safe function on your product to prevent secondary damages that may be caused by the abnormal function or the failure of our product.

■ Notice (Storage and Operating Condition)

To keep solderability of product from declining, the following storage condition is recommended.

1. Storage condition:
Temperature -10 to +40 degree C
Humidity less than 75%RH (not dewing condition)
2. Storage term:
Use this product within 6 months after delivery by first-in and first-out stocking system.

3. Handling after unpacking:
After unpacking, reseal product promptly or store it in a sealed container with a drying agent.
4. Storage place:
Do not store this product in corrosive gas (sulfuric acid gas, chlorine gas, etc.) or in direct sunlight.

■ Notice (Rating)

Use this product within the specified temperature range.

Higher temperature may cause deterioration of the characteristics or the material quality of this product.

■ Notice (Soldering and Mounting)

1. Be sure that the preheat-up does not melt the soldering of this product. Excessive heat may cause failure to open, short or insulation break down.
2. Do not touch the body with soldering iron.
The soldering point should be min. 5mm away from the root of lead wire.

■ Notice (Handling)

1. The ceramic element of this product is fragile, and care must be taken not to load an excessive press-force or not to give a shock at handling. Such forces may cause cracking or chipping.
2. Do not apply an excessive force to the lead. Otherwise, it may cause junction between lead and element to break or crack. Holding element by side lead wire is recommended when lead wire is bent or cut.

NTC/PTC Thermistors for Automotive



PTC Thermistor (POSISTOR®) for Overheat Sensing Chip Type 0603 (1608) Size

This chip "POSISTOR" is SMD type for overheat sensing for power transistors, power diodes and power ICs in hybrid circuits.

■ Features

1. SMD type is helpful for miniaturizing the circuit because of small size and light weight.
2. Excellent thermal response because of no coating.
3. Elements of solid-state construction provides excellent mechanical vibration and impact resistance.
4. Contactless operation provides prolonged service life and noiseless operation.
5. Lead is not contained in the terminations.

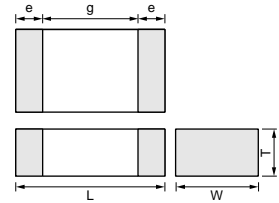

| Part Number | Dimensions (mm) | | | | |
|-----------------|-----------------|----------|----------|------------|---|
| | L | W | T | e | g |
| PRF18 RB | 1.6±0.15 | 0.8±0.15 | 0.8±0.15 | 0.1 to 0.6 | - |

| Part Number | Sensing Temperature (at 4.7k ohm) (°C) | Maximum Voltage (V) | Resistance (at 25°C) (ohm) | Temperature Range (°C) |
|------------------------|--|---------------------|----------------------------|------------------------|
| PRF18BG471QS2RB | 65 ±5°C | 32 | 470 ±50% | -40 to 150 |
| PRF18BF471QS2RB | 75 ±5°C | 32 | 470 ±50% | -40 to 150 |
| PRF18BE471QS2RB | 85 ±5°C | 32 | 470 ±50% | -40 to 150 |
| PRF18BD471QS2RB | 95 ±5°C | 32 | 470 ±50% | -40 to 150 |
| PRF18BC471QS2RB | 105 ±5°C | 32 | 470 ±50% | -40 to 150 |
| PRF18BB471QS2RB | 115 ±5°C | 32 | 470 ±50% | -40 to 150 |
| PRF18BA471QS2RB | 125 ±5°C | 32 | 470 ±50% | -40 to 150 |
| PRF18AR471QS2RB | 135 ±5°C | 32 | 470 ±50% | -40 to 150 |
| PRF18AS471QS2RB | 145 ±5°C | 32 | 470 ±50% | -40 to 150 |

5

■ Standard Land Pattern Dimensions

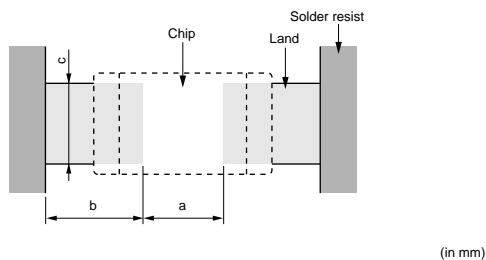

| Part Number | Soldering Methods | Dimensions (mm) | | | |
|--------------|-------------------|-----------------|---------|---------|---------|
| | | Chip (L×W) | a | b | c |
| PRF18 | Flow Soldering | 1.6×0.8 | 0.6-1.0 | 0.8-0.9 | 0.6-0.8 |
| | Reflow Soldering | | 0.6-0.8 | 0.6-0.7 | 0.6-0.8 |

■ Resistance-Temperature Characteristics (Typical)

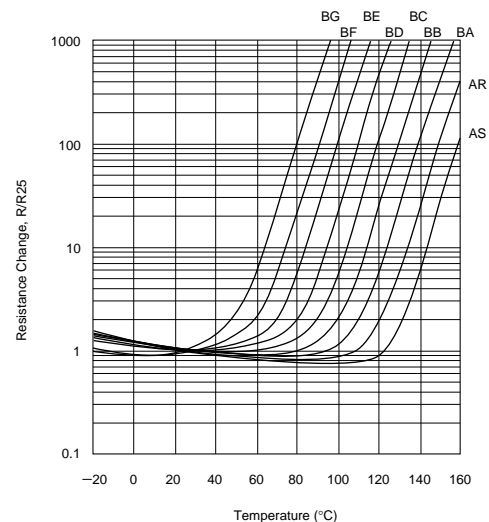

Continued on the following page. ↗

↳ Continued from the preceding page.

■ Overheat Protection Circuit

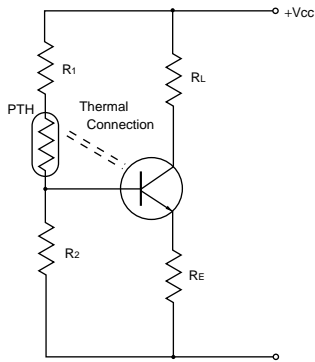

■ Overheat Sensing Circuit

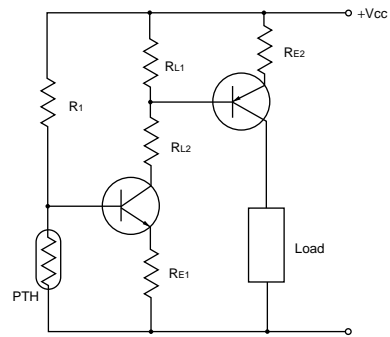

■ Resistance-Temperature Characteristics Range (Ref. Only)

PRF18BG471QS2RB

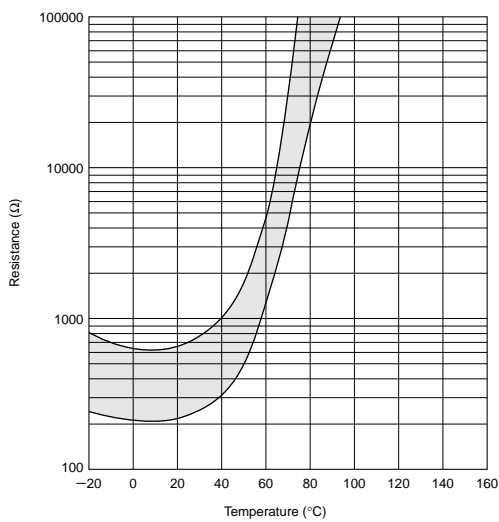

PRF18BF471QS2RB

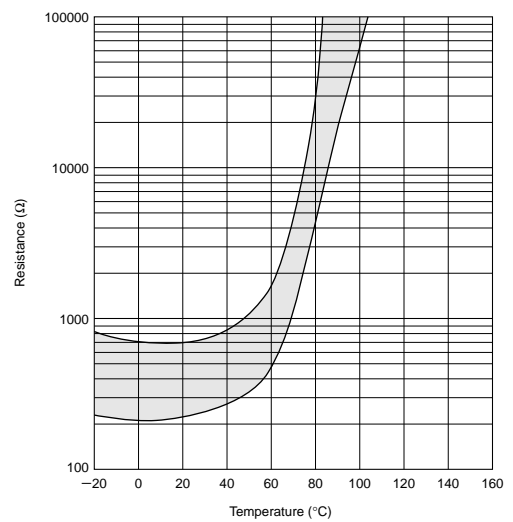

PRF18BE471QS2RB

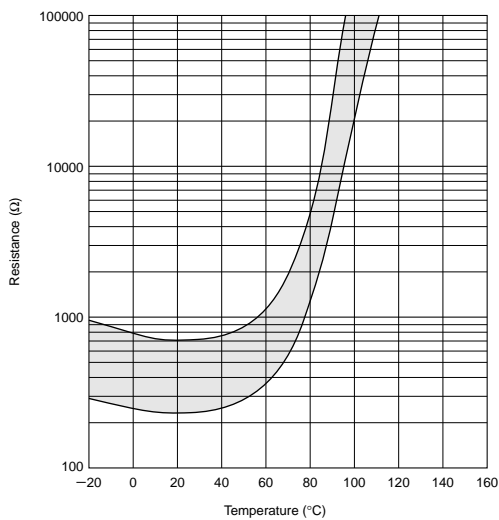

PRF18BD471QS2RB

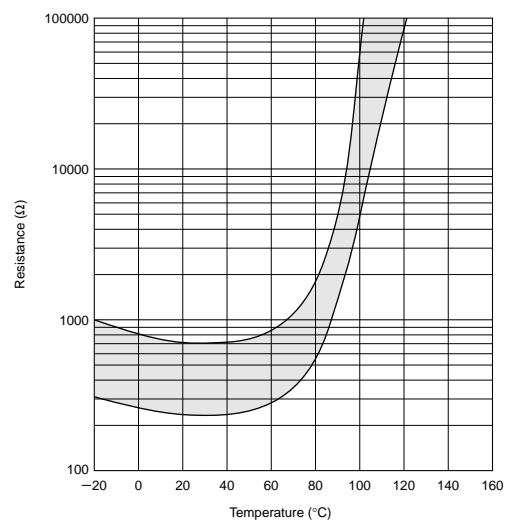

Continued on the following page. ↗

5

Continued from the preceding page.

■ Resistance-Temperature Characteristics Range (Ref. Only)

PRF18BC471QS2RB

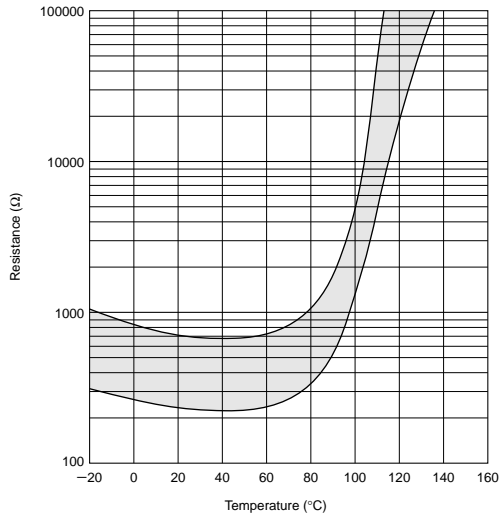

PRF18BB471QS2RB

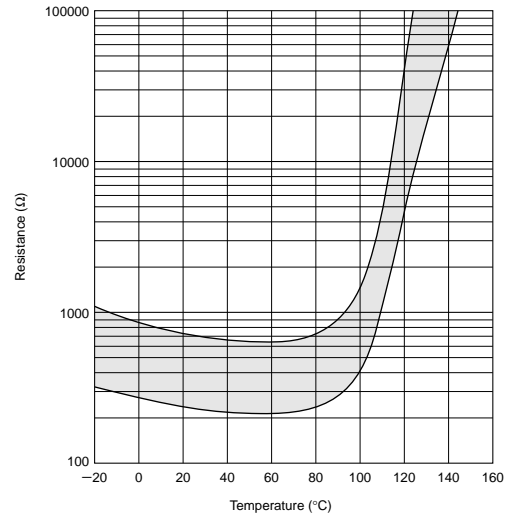

PRF18BA471QS2RB

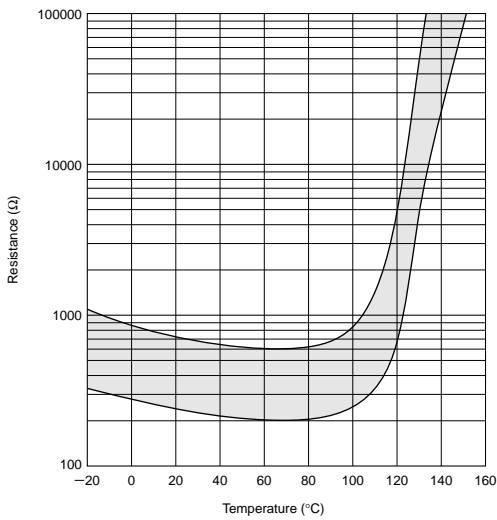

PRF18AR471QS2RB

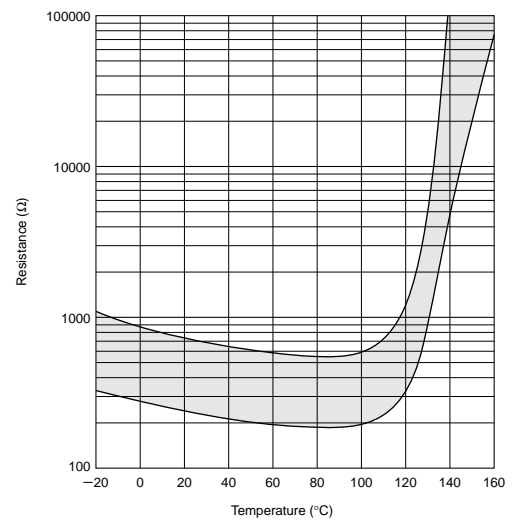

PRF18AS471QS2RB

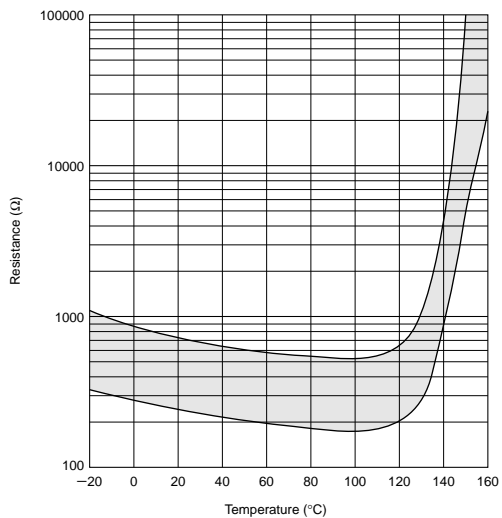

5

Chip Type of POSISTOR® for Overheat Protection Specifications and Test Methods

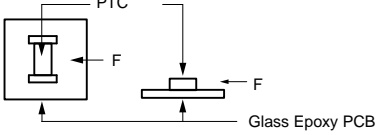
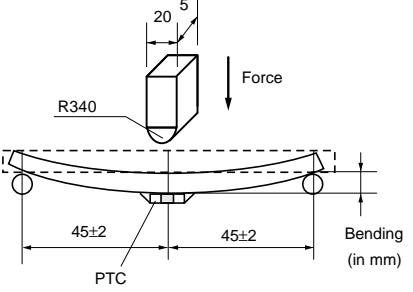
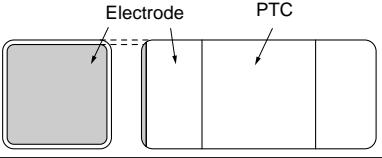
| No. | Item | Rating Value | Method of Examination | | | | | | | | | |
|------|------------------------------------|---|---|------|------------|-------------|---|-----------|----|---|------------|----|
| 1 | Resistance Value (at 25°C) | The resistance value should be within the specified tolerance. | After applying max. operating voltage for 3 mins. and leaving for 2 hrs. at 25°C, measured by applying voltage of less than 1.5Vdc (by a direct current less than 10mA). | | | | | | | | | |
| 2 | Adhesive Strength | There is no detachment sign of electrode. | EIAJ ET-7403 term 9 Prepare soldered PTC to PCB *1 and add the force of 5.0N in the direction shown below. (PTC=POSISTOR®)  | | | | | | | | | |
| 3 | Vibration Resistance | Normal appearance Resistance change: not exceed ±20% *2 | Soldered PTC to PCB *1 Vibration: 10-2000-10Hz (20 min.) Max. Amplitude: 3.0mm Vibrate for 4 hrs. in each of 3 mutually perpendicular planes for a total of 12 hrs. This test condition is according to "MIL-STD-204D" | | | | | | | | | |
| 4 | Resistance to Bending of Substance | Normal appearance Resistance change: not exceed ±20% *2 | Soldered PTC on Test Board *1, and apply force on back side of Test Board shown below: Bending Speed: 1.0mm/s Bending Strength: 2.0mm Hold time: 5±1 sec. Board Dimension: 100 × 40 × 1.6t mm Board Material: Glass Epoxy  | | | | | | | | | |
| 5 | Solderability | Min. 95% electrode is covered with new solder. Resistance change: not exceed ±20% *2 | JIS C 5102 term 8.4 Solder temp.: 230±5°C Solder: Sn63%/Pb37% (or 60%/40%) Soaking time: 3±0.5 secs. Soaking position: Until a whole electrode is soaked | | | | | | | | | |
| 6 | Soldering Heat Resistance | Resistance change: not exceed ±20% *2 Normal appearance on the section showed by slanting line parts of the electrodes on the figure.  | Solder temp.: 260±5°C Solder: Sn63%/Pb37% (or 60%/40%) Flux: Containing less than 0.2wt% of chlorine. Soaking time: 10±0.5 secs. Soaking position: Until a whole electrode is soaked. Preheating: 150±5°C 3 mins. | | | | | | | | | |
| 7 | Dry Heat Resistance | Normal appearance Resistance change: not exceed ±20% *2 | Soldered PTC to PCB. *1 +150±3°C leave for 1000±12 hrs. | | | | | | | | | |
| 8 | Cold Resistance | | Soldered PTC to PCB. *1 -40±3°C leave for 1000±12 hrs. | | | | | | | | | |
| 9 | Damp Heat Resistance | | Soldered PTC to PCB. *1 +85±3°C 80-85%RH leave for 1000±12 hrs. | | | | | | | | | |
| 10 | Thermal Shock *3 | | Soldered PTC to PCB. *1 Cycles: 1000 cycles <table border="1" style="margin-left: auto; margin-right: auto;"> <thead> <tr> <th>Step</th> <th>Temp. (°C)</th> <th>Time (min.)</th> </tr> </thead> <tbody> <tr> <td>1</td> <td>-55+0, -3</td> <td>30</td> </tr> <tr> <td>2</td> <td>+125+3, -0</td> <td>30</td> </tr> </tbody> </table> | Step | Temp. (°C) | Time (min.) | 1 | -55+0, -3 | 30 | 2 | +125+3, -0 | 30 |
| Step | Temp. (°C) | | Time (min.) | | | | | | | | | |
| 1 | -55+0, -3 | 30 | | | | | | | | | | |
| 2 | +125+3, -0 | 30 | | | | | | | | | | |
| 11 | High Temperature Humidity Load | Soldered PTC to PCB. *1 85±3°C, 80-85%RH (in air), load max. operating voltage for 1000±12 hrs. | | | | | | | | | | |

Continued on the following page.

Chip Type of POSISTOR[®] for Overheat Protection Specifications and Test Methods

☐ Continued from the preceding page.

| No. | Item | Rating Value | Method of Examination |
|-----|-----------------------|--|---|
| 12 | High Temperature Load | Normal appearance Resistance change: not exceed $\pm 20\%$ *2 | Soldered PTC to PCB. *1 +85 \pm 3°C (in air), load max. operating voltage for 1000 \pm 12 hrs. |

*1 Above mentioned soldering is done under the following conditions at our side.

- Glass-Epoxy PC board
- Recommendable land dimension
- Recommendable solder paste
- Recommendable solder profile

Above conditions are mentioned in Notice.

*2 Measure resistance after the test. by applying voltage less than 1.5Vdc. by a direct current of less than 10mA. after product is left at 25 \pm 2°C for 2hrs.

*3 We cannot guarantee the resistance change in Thermal Shock (No.10) in case of defective mounting.

NTC/PTC Thermistors for Automotive



PTC Thermistor (POSISTOR[®]) for Overcurrent Protection Chip Type 0805 (2012) Size

Overcurrent Protection device with resettable function suitable for current limiting resistor.

This product is chip type PTC thermistor for overcurrent protection which is suitable for the following

- Countermeasure for short circuit testing
- Current limiting resistor

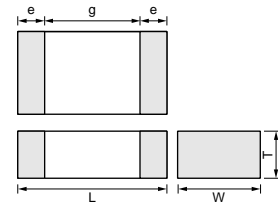

| Part Number | Dimensions (mm) | | | | |
|-----------------|-----------------|----------|----------|------------|----------|
| | L | W | T | e | g |
| PRG18_RB | 1.6±0.15 | 0.8±0.15 | 0.8±0.15 | 0.1 to 0.6 | - |
| PRG21_RA | 2.0±0.2 | 1.25±0.2 | 0.9±0.2 | 0.2 min. | 0.5 min. |
| PRG21_RK | 2.0±0.2 | 1.25±0.2 | 1.25±0.2 | 0.2 min. | 0.5 min. |

■ Features

1. Rapid operation to protects the circuit in an overcurrent condition abnormality such as a short circuit.
By removing the overcurrent condition, these products automatically return to the initial condition and can be used repeatedly.
2. Suitable for countermeasure to short circuit test in safety standard.
3. Stable resistance after operation due to ceramic PTC.
4. Similar size (0603 size) is possible due to the large capacity for electric power.
5. Possible to use these products as current limiting resistors with overcurrent protection functions.
6. SMD type is helpful for miniaturizing circuits because of its small size and light weight.
7. Lead is not contained in the terminations.

6

| Part Number | Max. Voltage (V) | Non-operating Current (at +85°C) (mA) | Non-operating Current (at +105°C) (mA) | Trip Current (at -40°C) (mA) | Max. Current (mA) | Resistance (at 25°C) (ohm) | Curie Point (°C) | Temperature Range (°C) |
|------------------------|------------------|---------------------------------------|--|------------------------------|-------------------|----------------------------|------------------|------------------------|
| PRG21AR420MS1RA | 20 | 25 | 15 | 130 | 590 | 42 ±20% | 120 (AR) | -40 to 105 |
| PRG21AR220MS1RK | 16 | 45 | 25 | 250 | 900 | 22 ±20% | 120 (AR) | -40 to 105 |

■ Standard Land Pattern Dimensions

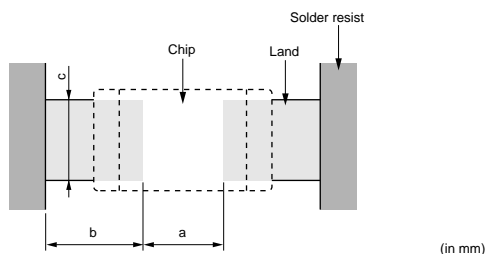

| Part Number | Soldering Methods | Dimensions (mm) | | | |
|--------------|-------------------|-----------------|---------|---------|---------|
| | | Chip (L×W) | a | b | c |
| PRG18 | Reflow Soldering | 1.6×0.8 | 0.6-0.8 | 0.6-0.7 | 0.6-0.8 |
| PRG21 | Reflow Soldering | 2.0×1.25 | 1.0-1.2 | 0.5-0.7 | 1.0-1.2 |

■ Protective Threshold Current Range

PRG21AR220MS1RK

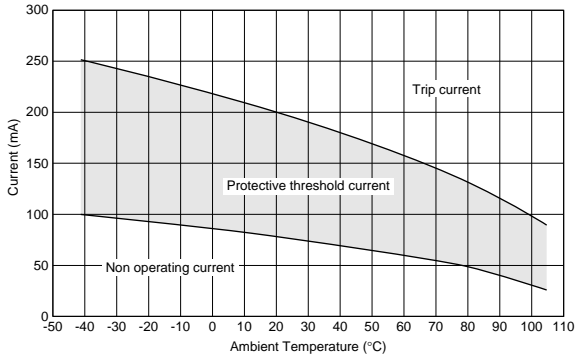

PRG21AR420MS1RA

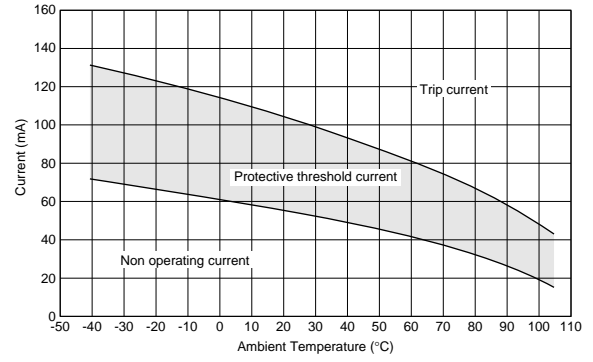

■ Operating Time (Typical Curve)

PRG21AR220MS1RK

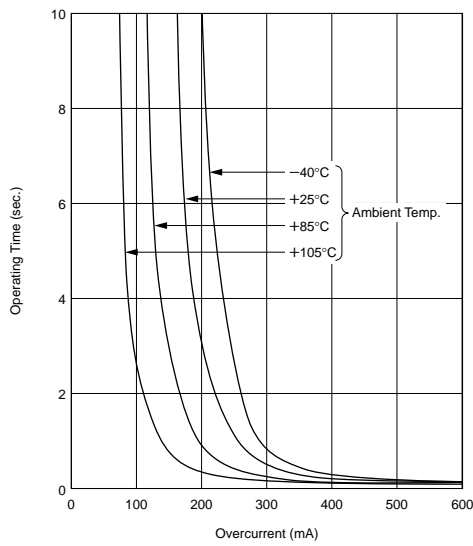

PRG21AR420MS1RA

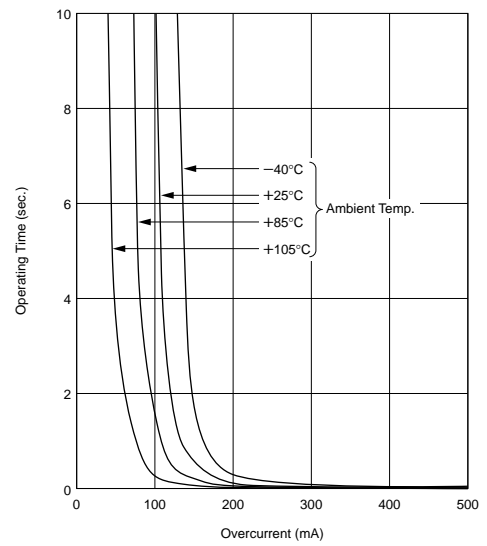

Chip Type of POSISTOR® for Overheat Protection Specifications and Test Methods

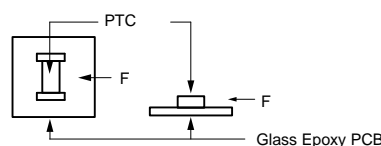
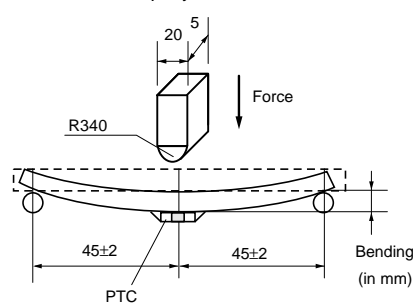
| No. | Item | Rating Value | Method of Examination | | | | | | | | |
|------|------------------------------------|---|--|------|------------|-------------|---|-----------|----|---|------------|
| 1 | Operating Temp. 1 | -40 to +105°C | The temperature range with maximum voltage applied the POSISTOR®. | | | | | | | | |
| 2 | Operating Temp. 2 | -40 to +125°C | The temperature range which with zero voltage applied to POSISTOR® after it was soldered to PCB. | | | | | | | | |
| 3 | Resistance Value (at 25°C) | The resistance value shall be within the specified tolerance. | After applying maximum Operating voltage for 3 minutes and leaving for 2 hours at 25°C, measured by applying voltage of less than 1.5Vdc (by a direct current less than 10mA). | | | | | | | | |
| 4 | Withstanding Voltage | Without damage | We apply 120% of the maximum voltage to PTC by rising gradually for 180±5 seconds at 25°C. (A protective resistor is to be connected in series, and the inrush current through PTC must be limited below maximum rated value.) | | | | | | | | |
| 5 | Adhesive Strength | There is no detachment sign of electrode. | EIAJ ET-7403 term 9 Prepare soldered PTC to PCB *1 and add the force of 5.0N in the direction shown below. (PTC=POSISTOR®)  | | | | | | | | |
| 6 | Vibration Resistance | Normal appearance Resistance change: not exceed ±20% *2 | Soldered PTC to PCB *1 Vibration: 10-2000-10Hz (20 min.) Max. Amplitude: 3.0mm Vibrate for 4 hours in each of 3 mutually perpendicular planes for a total of 12 hours. This test condition is according to "MIL-STD-204D" | | | | | | | | |
| 7 | Resistance to Bending of Substance | Normal appearance Resistance change: not exceed ±20% *2 | Soldered PTC on Test Board *1, and apply force on back side of Test Board shown below: Bending Speed: 1.0mm/s Bending Strength: 2.0mm Hold Time: 5±1 sec. Board Dimension: 100×40×1.6t mm Board Material: Glass Epoxy  | | | | | | | | |
| 8 | Solderability | Min. 95% electrode is covered with new solder. Resistance change: not exceed ±20% *2 | JIS C 5102 term 8.4 Solder Temp.: 230±5°C Solder: Sn63%/Pb37% (or 60%/40%) Soaking Time: 3±0.5 sec. Soaking Position: Until a whole electrode is soaked | | | | | | | | |
| 9 | Soldering Heat Resistance | Normal appearance Resistance change: not exceed ±20% *2 | Solder: Sn 63/37 Pb (or 60/40) solder paste Containing less than 0.2wt% of chlorine. Preheating: 150±5°C 3 min. Peak Temp.: 260±5°C 10±5 sec. (reflow) PCB: JIS C 6484 Glass Epoxy PCB | | | | | | | | |
| 10 | Dry Heat Resistance | Normal appearance Resistance change: not exceed ±20% *2 | Soldered PTC to PCB. *1 +125±3°C leave for 1000±12 hours. | | | | | | | | |
| 11 | Cold Resistance | | Soldered PTC to PCB. *1 -40±3°C leave for 1000±12 hours. | | | | | | | | |
| 12 | Damp Heat Resistance | | Soldered PTC to PCB. *1 +85±3°C 80-85%RH leave for 1000±12 hours. | | | | | | | | |
| 13 | Thermal Shock *3 | | Soldered PTC to PCB. *1 Cycles: 1000 cycles <table border="1" style="width: 100%; border-collapse: collapse;"> <thead> <tr> <th>Step</th> <th>Temp. (°C)</th> <th>Time (min.)</th> </tr> </thead> <tbody> <tr> <td>1</td> <td>-55+0, -3</td> <td>30</td> </tr> <tr> <td>2</td> <td>+125+3, -0</td> <td>30</td> </tr> </tbody> </table> | Step | Temp. (°C) | Time (min.) | 1 | -55+0, -3 | 30 | 2 | +125+3, -0 |
| Step | Temp. (°C) | Time (min.) | | | | | | | | | |
| 1 | -55+0, -3 | 30 | | | | | | | | | |
| 2 | +125+3, -0 | 30 | | | | | | | | | |

Continued on the following page. ↗

Chip Type of POSISTOR[®] for Overheat Protection Specifications and Test Methods

↳ Continued from the preceding page.

| No. | Item | Rating Value | Method of Examination |
|-----|--------------------------------|--|--|
| 14 | High Temperature Humidity Load | Normal appearance Resistance change: not exceed $\pm 20\%$ *2 | Soldered PTC to PCB. *1 85 $\pm 3^{\circ}\text{C}$, 80-85%RH (in air), load max. operating voltage for 1000 ± 12 hrs. |
| 15 | High Temperature Load | | Soldered PTC to PCB. *1 125 $\pm 3^{\circ}\text{C}$ (in air), PTC is applied max. operating voltage for 1.5 hrs on and 0.5 hrs off. This cycle is repeated for 1000 ± 10 hrs. |

*1 Above mentioned soldering is done under the following conditions at our side.

- Glass-Epoxy PC board
 - Recommendable land dimension
 - Recommendable solder paste
 - Recommendable solder profile
- Above conditions are mentioned in Notice.

*2 Measure resistance after the test. by applying voltage less than 1.5Vdc. by a direct current of less than 10mA. after product is left at 25 $\pm 2^{\circ}\text{C}$ for 2hrs.

*3 We cannot guarantee the resistance change in Thermal Shock (No.10) in case of defective mounting.

for POSISTOR[®] Chip Type ⚠Caution/Notice

■ ⚠Caution (Storage and Operating Condition)

This product is designed for application in an ordinary environment (normal room temperature, humidity and atmospheric pressure). Do not use under the following conditions because all these factors can deteriorate the characteristics or cause product failure and burn-out.

1. Corrosive gas or deoxidizing gas (Chlorine gas, Hydrogen sulfide gas, Ammonia gas, Sulfuric acid gas, Nitric oxide gas, etc.)
2. Volatile or flammable gas
3. Dusty conditions
4. Under vacuum, or under high or low-pressure
5. Wet or humid conditions
6. Places with salt water, oils, chemical liquids or organic solvents
7. Strong vibrations
8. Other places where similar hazardous conditions exist

■ ⚠Caution (Other)

Be sure to provide an appropriate fail-safe function on your product to prevent secondary damage that may be caused by the abnormal function or the failure of our product.

■ Notice (Storage and Operating Condition)

To keep solderability of product from declining, following storage condition is recommended.

1. Storage condition:
 - Temperature -10 to +40 degree C
 - Humidity less than 75%RH (not dewing condition)
2. Storage term:
 - Use this product within 6 months after delivery by first-in and first-out stocking system.
3. Handling after unpacking:
 - After unpacking, promptly reseal this product or store it in a sealed container with a drying agent.
4. Storage place:
 - Do not store this product in corrosive gas (sulfuric acid, chlorine, etc.) or in direct sunlight.

for POSISTOR[®] Chip Type ⚠️Caution/Notice

■ Notice (Soldering and Mounting) 0603 (1608) Size

1. Solder and Flux

(1) Solder Paste

(a) Flow Soldering : Use Sn:Pb=60:40wt%, Sn:Pb=63:37wt%, Sn:Ag:Cu=96.5:3.0:0.5wt% or equivalent type of solder.

(b) Reflow Soldering : Use Sn:Pb=60:40wt%, Sn:Pb=63:37wt%, Sn:Ag:Cu=96.5:3.0:0.5wt% or equivalent type of solder paste.

For your reference, we are using '63Sn/37Pb RMA9086 90-3-M18', manufactured by Alpha Metals Japan Ltd., '96.5Sn/3.0Ag/0.5Cu M705-221BM5-42-11', manufactured by Senju Metal Industry Co., Ltd. for any Internal tests of this product.

(2) Flux

Use rosin-based flux. Do not use strong acidic flux (with halide content exceeding 0.2wt%).

2. Cleaning Conditions and Drying

To remove the flux after soldering, observe the following points in order to avoid deterioration of the characteristics or any change to the external electrodes quality.

(1) Cleaning Conditions

| Solvent | Dipping Cleaning | Ultrasonic Cleaning |
|------------|---|--|
| 2-propanol | Less than 5 min. at room temp. or Less than 2 min. at 40°C max. | Less than 1 min. 20W/L Frequency of several 10kHz to 100kHz. |

A sufficient cleaning should be applied to remove flux completely.

(2) Drying

After cleaning, promptly dry this product.

3. Soldering Conditions

In your mounting process, observe the following points in order to avoid deterioration of the characteristics or destruction of this product. The mounting quality of this product may also be affected by the mounting conditions, shown in the points below.

(1) Printing Conditions of Solder Paste

- (a) Recommendable thickness of solder paste printing should be from 0.15 to 0.20mm.
- (b) After soldering, the solder fillet should be a height from 0.2 mm to the thickness of this product (see the figure at right).
- (c) Too much solder gives too strong mechanical stress to this product. Such stress may cause cracking or other mechanical damage. Also, it can destroy the electrical performance of this product.

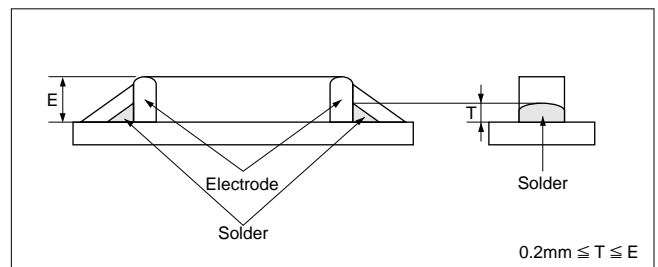

Continued on the following page. ↗

for POSISTOR[®] Chip Type ⚠Caution/Notice

Continued from the preceding page.

(2) Adhesive Application and Curing

- (a) If insufficient adhesive is applied, or if the adhesive is not sufficiently hardened, this product may have a loose contact with the land, during flow soldering.
- (b) Too low viscosity of adhesive causes this product to slip on board, after mounting.

(3) Allowable Soldering Temperature and Time

- (a) Solder within the temperature and time combinations, indicated by the slanted lines in the following graphs.
- (b) The excessive soldering conditions may cause dissolution of metallization or deterioration of solder-wetting on the external electrode.
- (c) In the event that soldering is repeated more than twice, the allowable reflow soldering time should be the accumulated soldering time.

[Allowable Flow Soldering Temp. and Time]

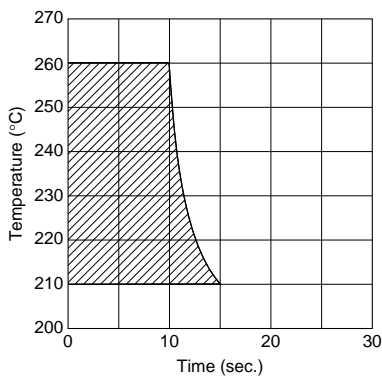

[Allowable Reflow Soldering Temp. and Time]

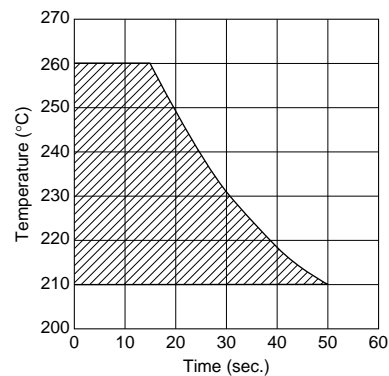

(4) Recommendable Temperature Profile for Soldering

- (a) Insufficient preheating may cause a crack on ceramic body. Difference between preheating temperature and maximum temperature in the profile should be 100°C.
- (b) Rapid cooling by dipping in solvent or by other means is not recommended.

[Flow Soldering Condition]

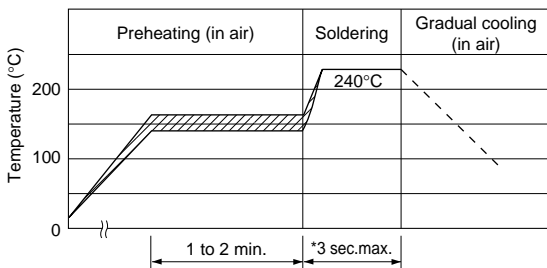

Preheating: 150±10°C, 1 min. to 2 min.
Soldering: 240°C, 3 sec. max.

* In the event that soldering is repeated more than twice the accumulated soldering time should be in the above allowable soldering time (3).

[Reflow Soldering Condition]

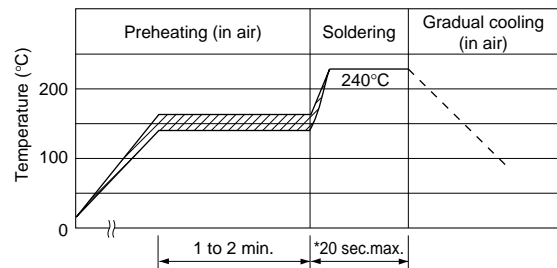

Preheating: 150±10°C, 1 min. to 2 min.
Soldering: 240°C, 20 sec. max.

* In the event that soldering is repeated more than twice the accumulated soldering time should be in the above allowable soldering time (3).

- (5) There may be a risk of unexpected failures (tombstone, insufficient solder-wetting, etc.) in the mounting process caused by the mounting conditions. Please make sure that this product is correctly mounted under specified mounting conditions.

for POSISTOR[®] Chip Type ⚠️Caution/Notice

■ Notice (Soldering and Mounting) 0805 (2012) Size

1. Solder and Flux

(1) Solder Paste

Use solder paste Sn:Pb=63:37wt%.

For your reference, we are using

63Sn/37Pb RMA9086 90-3-M18,

manufactured by Alpha Metals Japan Ltd.

96.5Sn/3.0Ag/0.5Cu M705-221BM5-42-11,

manufactured by Senju Metal Industry Co., LTD for any

Internal tests of this product.

(2) Flux

Use rosin-based flux. Do not use strong acidic flux

(with halide content exceeding 0.2wt%).

2. Cleaning Conditions and Drying

To remove the flux after soldering, observe the following points in order to avoid deterioration of the characteristics or any change to the external electrodes quality.

(1) Cleaning Conditions

| Solvent | Dipping Cleaning | Ultrasonic Cleaning |
|------------|---|---|
| 2-propanol | Less than 5 min. at room temp. or Less than 2 min. at 40°C max. | Less than 1 min. 20W/L Frequency of several 10kHz to 100kHz. |

A sufficient cleaning should be applied to remove flux completely.

(2) Drying

After cleaning, promptly dry this product.

3. Soldering Conditions

In your mounting process, observe the following points in order to avoid deterioration of the characteristics or destruction of this product. The mounting quality of this product may also be affected by the mounting conditions, shown in the points below.

This product is for only reflow soldering. Flow soldering should not be allowed.

(1) Printing Conditions of Solder Paste

- (a) Standard thickness of solder paste printing should be from 0.15 to 0.20 mm.
- (b) After soldering, the solder fillet should be a height from 0.2 mm to the thickness of this product (see the figure at right).
- (c) Too much solder gives too strong mechanical stress to this product. Such stress may cause cracking or other mechanical damage. Also, it can destroy the electrical performance of this product.

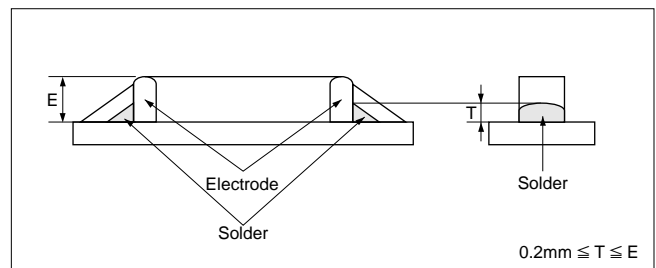

Continued on the following page. ↗

for POSISTOR[®] Chip Type ⚠Caution/Notice

☐ Continued from the preceding page.

(2) Allowable Soldering Temperature and Time

- (a) Solder within the temperature and time combinations, indicated by the slanted lines in the right graphs.
- (b) The excessive soldering conditions may cause dissolution of metallization or deterioration of solder-wetting on the external electrode.
- (c) In the event that soldering is repeated more than twice, the allowable reflow soldering time should be the accumulated soldering time.

[Allowable Reflow Soldering Temp. and Time]

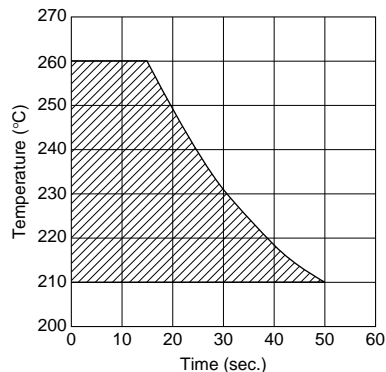

(3) Standard Temperature Profile for Soldering

- (a) Insufficient preheating may cause a crack on ceramic body. Difference between preheating temperature and maximum temperature in the profile should be 100°C.
- (b) Rapid cooling by dipping in solvent or by other means is not recommended.

[Reflow Soldering Condition]

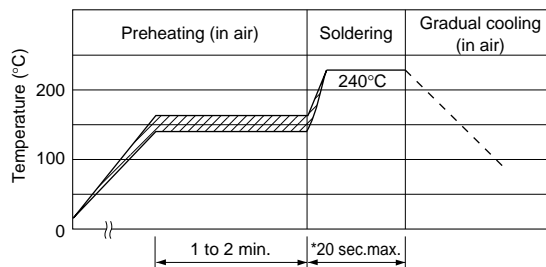

Preheating: 150±10°C, 1 to 2min.
Soldering: 240°C, 20 sec. max.

*In the event that soldering is repeated more than twice the accumulated soldering time should be in the above allowable soldering time (2).

- (4) There may be a risk unexpected failures (tombstone, insufficient solder-wetting, etc.) in the mounting process, caused by the mounting conditions. Please make sure that this product is correctly mounted under specified mounting conditions.

for POSISTOR[®] Chip Type ⚠Caution/Notice

■ Notice (Handling)

1. Do not give this product a strong press-force nor a mechanical shock, because such mechanical forces may cause cracking or chipping of this ceramic product.
2. Rapid cooling or heating during soldering is not recommended.
Such treatment may destroy the element.
3. Resin coating
Please select a resin material with minimum hardness shrinkage is much less, on selecting a resin material.
4. Location on Printed Circuit Board (PC Board)
Choose a mounting position that minimizes the stress imposed on the chip during flexing or bending of the board.

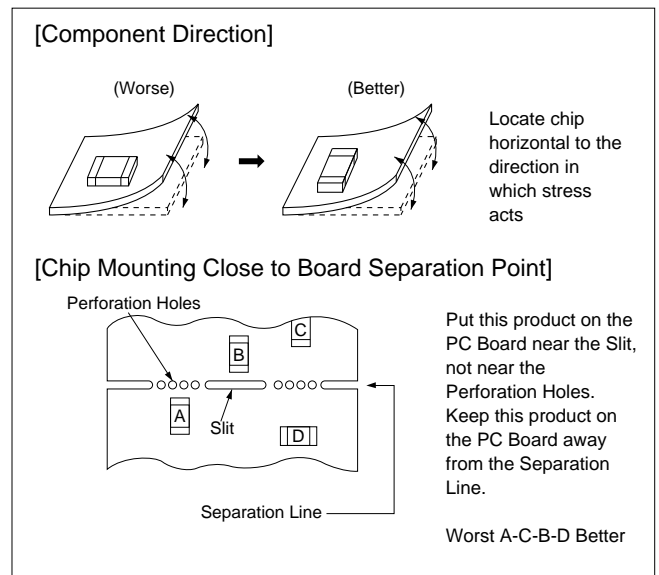

NTC/PTC Thermistors for Automotive



PTC Thermistor (POSISTOR®) for Overcurrent Protection Lead Type

New leaded type "POSISTOR" for overcurrent protection as automotive grade can be used with wide temperature range. This product is suitable for short-circuit and current limiting resistor on power supply equipment.

■ Features

1. This product has useful Protective threshold current range with wide temperature range.
2. Small fluctuation in the circuit due to resistance tolerance +/-10%.
3. Quick operating time due to small size compared with conventional products.
4. Best suited to meet the requirements for power supply and motor protector. Error-free operations are assured by rush current.
5. Circuit is protected until current is turned off.
6. Restores the original low resistance value automatically once the overload is removed.
7. Non-contact design leads to long life and no noise.
Durable and strong against mechanical vibration and shock because it is a solid element.
8. Lead (Pb) is not contained in the terminations.

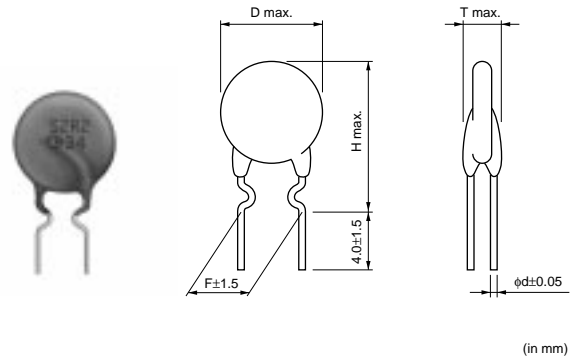

7

| Part Number | Max. Voltage (V) | Non-operating Current (at +85°C) (mA) | Non-operating Current (at +105°C) (mA) | Trip Current (at -40°C) (mA) | Max. Current (A) | Resistance (at 25°C) (ohm) | Curie Point (°C) | Temperature Range (°C) | Body Diameter (D) (mm) | Thickness (T) (mm) | Height (H) (mm) | Lead Space (F) (mm) | Lead Diameter (phi d) (mm) |
|--------------------|------------------|---------------------------------------|--|------------------------------|------------------|----------------------------|------------------|------------------------|------------------------|--------------------|-----------------|---------------------|----------------------------|
| PTGL4SAS100K2N51B0 | 30 | 92 | 65 | 261 | 1.5 | 10 ±10% | 130 (AS) | -40 to 125 | 4.5 | 3.5 | 9.5 | 5.0 | 0.5 |
| PTGL4SAS100K2B51B0 | 30 | 127 | 89 | 359 | 2.0 | 10 ±10% | 130 (AS) | -40 to 125 | 4.5 | 3.5 | 9.5 | 5.0 | 0.6 |
| PTGL5SAS3R9K2B51B0 | 30 | 204 | 143 | 576 | 3.5 | 3.9 ±10% | 130 (AS) | -40 to 125 | 5.5 | 3.5 | 10.5 | 5.0 | 0.6 |
| PTGL7SAS2R7K2B51B0 | 30 | 255 | 179 | 720 | 4.5 | 2.7 ±10% | 130 (AS) | -40 to 125 | 7.3 | 3.5 | 12.3 | 5.0 | 0.6 |
| PTGL7SAS1R8K2B51B0 | 30 | 319 | 223 | 902 | 5.0 | 1.8 ±10% | 130 (AS) | -40 to 125 | 7.3 | 3.5 | 12.3 | 5.0 | 0.6 |
| PTGL9SAS1R2K2B51B0 | 30 | 422 | 296 | 1193 | 6.0 | 1.2 ±10% | 130 (AS) | -40 to 125 | 9.3 | 3.5 | 14.3 | 5.0 | 0.6 |
| PTGLCSAS0R8K2B51B0 | 30 | 520 | 364 | 1470 | 7.0 | 0.8 ±10% | 130 (AS) | -40 to 125 | 11.5 | 3.5 | 16.5 | 5.0 | 0.6 |
| PTGL4SAS100K3B51B0 | 51 | 128 | 89 | 361 | 1.0 | 10 ±10% | 130 (AS) | -40 to 125 | 4.5 | 3.5 | 9.5 | 5.0 | 0.6 |
| PTGL5SAS6R8K3B51B0 | 51 | 149 | 105 | 422 | 1.5 | 6.8 ±10% | 130 (AS) | -40 to 125 | 5.5 | 3.5 | 10.5 | 5.0 | 0.6 |
| PTGL7SAS3R3K3B51B0 | 51 | 233 | 163 | 659 | 3.0 | 3.3 ±10% | 130 (AS) | -40 to 125 | 7.3 | 3.5 | 12.3 | 5.0 | 0.6 |
| PTGL9SAS2R2K3B51B0 | 51 | 313 | 219 | 885 | 4.0 | 2.2 ±10% | 130 (AS) | -40 to 125 | 9.3 | 3.5 | 14.3 | 5.0 | 0.6 |
| PTGLCSAS1R2K3B51B0 | 51 | 449 | 315 | 1270 | 5.0 | 1.2 ±10% | 130 (AS) | -40 to 125 | 11.5 | 3.5 | 16.5 | 5.0 | 0.6 |
| PTGL4SAS220K4N51B0 | 60 | 67 | 47 | 190 | 1.0 | 22 ±10% | 130 (AS) | -40 to 125 | 4.5 | 3.5 | 9.5 | 5.0 | 0.5 |
| PTGL4SAS220K4B51B0 | 60 | 87 | 61 | 246 | 1.0 | 22 ±10% | 130 (AS) | -40 to 125 | 4.5 | 3.5 | 9.5 | 5.0 | 0.6 |
| PTGL5SAS100K4B51B0 | 60 | 129 | 90 | 364 | 1.5 | 10 ±10% | 130 (AS) | -40 to 125 | 5.5 | 3.5 | 10.5 | 5.0 | 0.6 |
| PTGL7SAS5R6K4N51B0 | 60 | 142 | 99 | 400 | 2.2 | 5.6 ±10% | 130 (AS) | -40 to 125 | 7.3 | 3.5 | 12.3 | 5.0 | 0.5 |
| PTGL7SAS5R6K4B51B0 | 60 | 174 | 122 | 492 | 3.0 | 5.6 ±10% | 130 (AS) | -40 to 125 | 7.3 | 3.5 | 12.3 | 5.0 | 0.6 |
| PTGL9SAS3R3K4B51B0 | 60 | 253 | 177 | 714 | 4.0 | 3.3 ±10% | 130 (AS) | -40 to 125 | 9.3 | 3.5 | 14.3 | 5.0 | 0.6 |
| PTGLCSAS2R2K4B51B0 | 60 | 334 | 234 | 942 | 5.0 | 2.2 ±10% | 130 (AS) | -40 to 125 | 11.5 | 3.5 | 16.5 | 5.0 | 0.6 |
| PTGL4SAS560K6B51B0 | 140 | 56 | 39 | 159 | 0.5 | 56 ±10% | 130 (AS) | -40 to 125 | 5.5 | 4.5 | 10.5 | 5.0 | 0.6 |
| PTGL5SAS270K6B51B0 | 140 | 80 | 56 | 227 | 1.0 | 27 ±10% | 130 (AS) | -40 to 125 | 5.5 | 4.5 | 10.5 | 5.0 | 0.6 |
| PTGL7SAS150K6B51B0 | 140 | 112 | 79 | 317 | 1.5 | 15 ±10% | 130 (AS) | -40 to 125 | 7.3 | 4.5 | 12.3 | 5.0 | 0.6 |
| PTGL9SAS120K6B51B0 | 140 | 146 | 102 | 413 | 2.0 | 12 ±10% | 130 (AS) | -40 to 125 | 9.3 | 4.5 | 14.3 | 5.0 | 0.6 |
| PTGL9SAS7R6K6B51B0 | 140 | 172 | 121 | 486 | 2.2 | 7.6 ±10% | 130 (AS) | -40 to 125 | 9.3 | 4.5 | 14.3 | 5.0 | 0.6 |
| PTGLCSAS4R7K6B51B0 | 140 | 236 | 165 | 666 | 3.5 | 4.7 ±10% | 130 (AS) | -40 to 125 | 11.5 | 4.5 | 16.5 | 5.0 | 0.6 |

Maximum Current shows typical capacities of the transformer which can be used.
These series are recognized by UL.
Taping type is also available. (PTGL_A0 series)



■ Protective Threshold Current Range (30V Series)

PTGL4SAS100K2N51B0

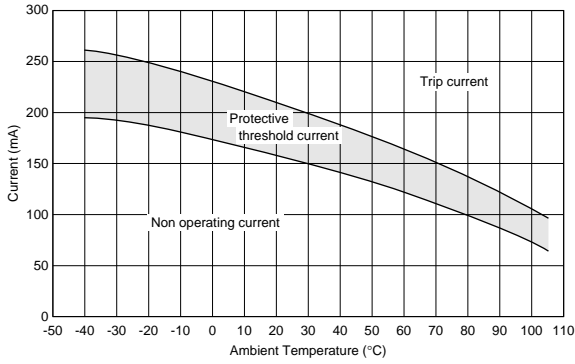

PTGL4SAS100K2B51B0

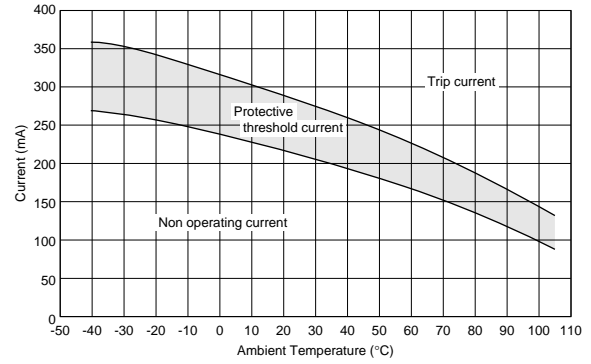

PTGL5SAS3R9K2B51B0

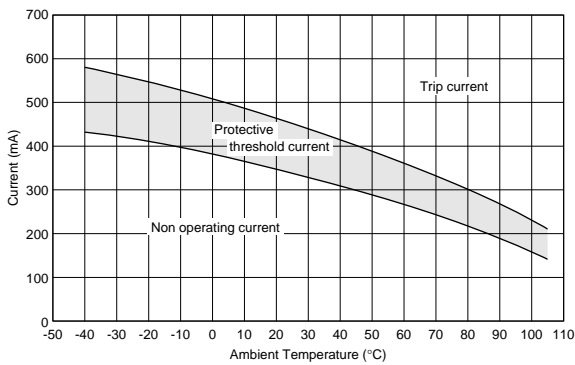

PTGL7SAS2R7K2B51B0

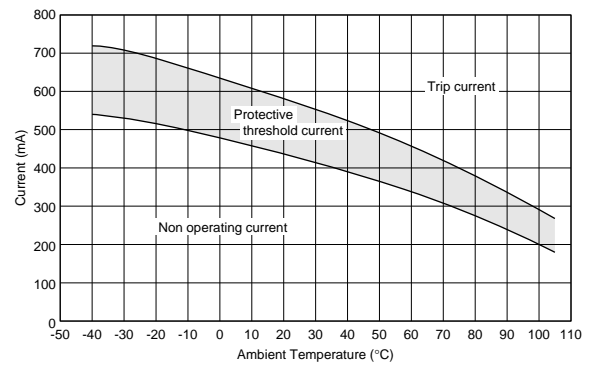

PTGL7SAS1R8K2B51B0

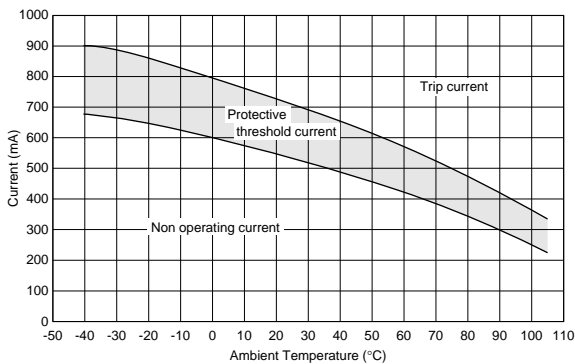

PTGL9SAS1R2K2B51B0

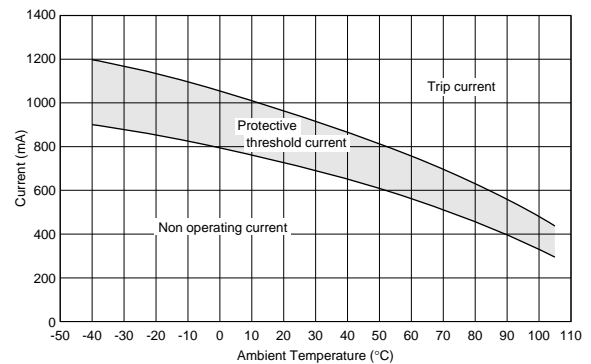

7

■ Protective Threshold Current Range (51V Series)

PTGLCSAS0R8K2B51B0

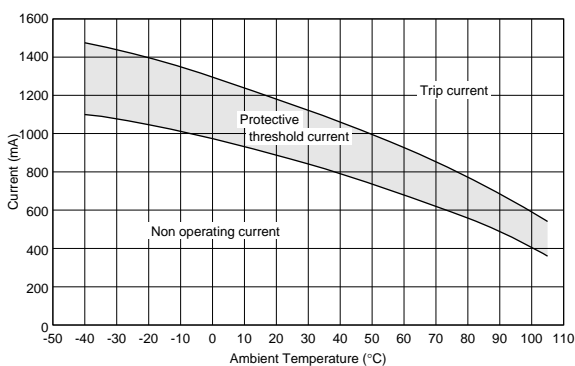

PTGL4SAS100K3B51B0

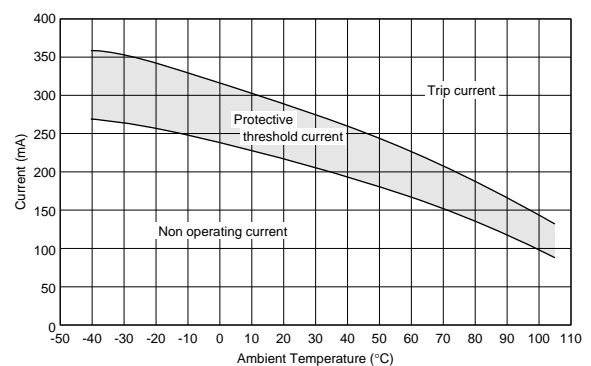

Continued from the preceding page.

■ Protective Threshold Current Range (51V Series)

PTGL5SAS6R8K3B51B0

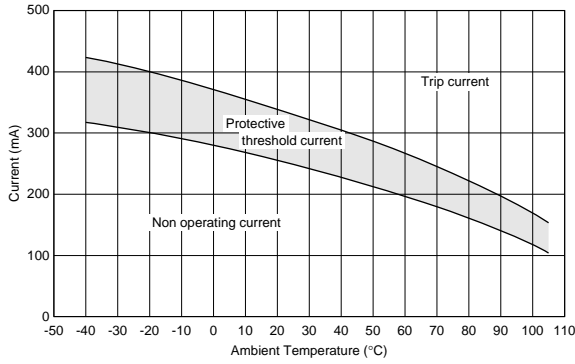

PTGL7SAS3R3K3B51B0

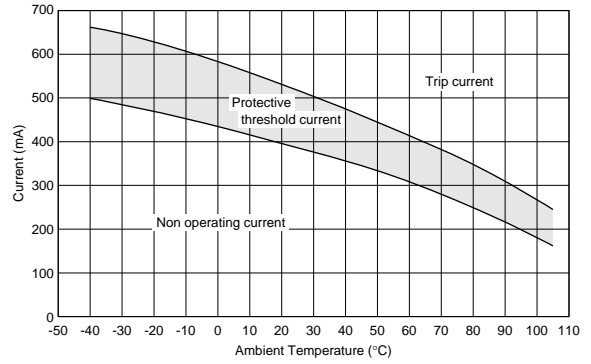

PTGL9SAS2R2K3B51B0

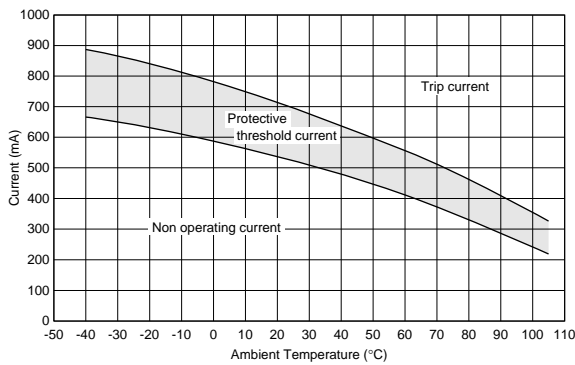

PTGLCSAS1R2K3B51B0

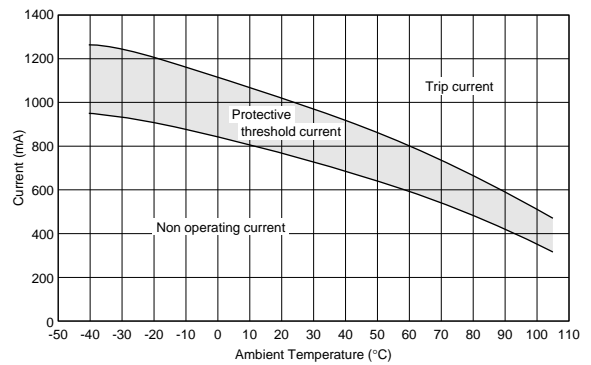

■ Protective Threshold Current Range (60V Series)

PTGL4SAS220K4N51B0

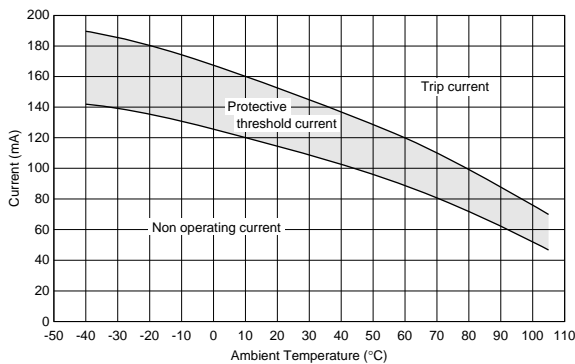

PTGL4SAS220K4B51B0

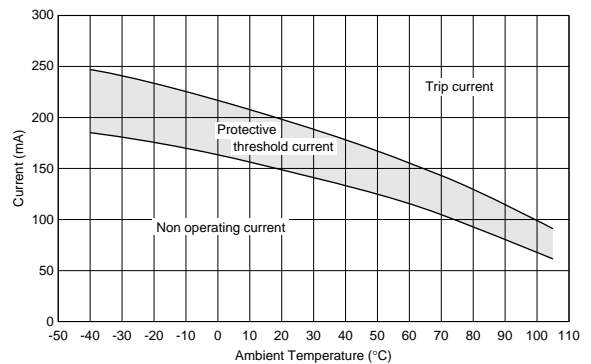

PTGL5SAS100K4B51B0

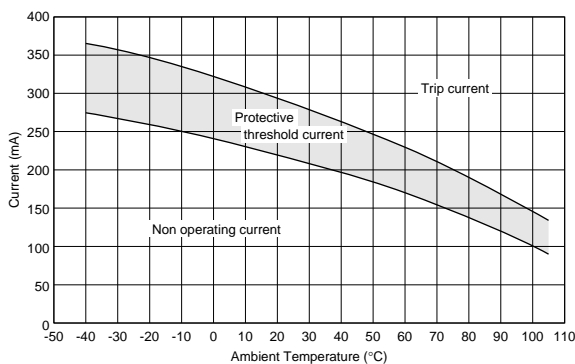

PTGL7SAS5R6K4N51B0

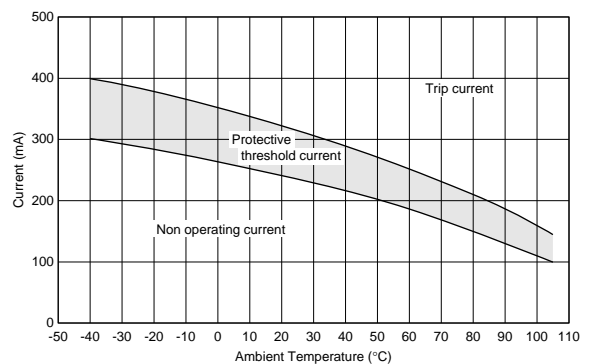

7

↳ Continued from the preceding page.

■ Protective Threshold Current Range (60V Series)

PTGL7SAS5R6K4B51B0

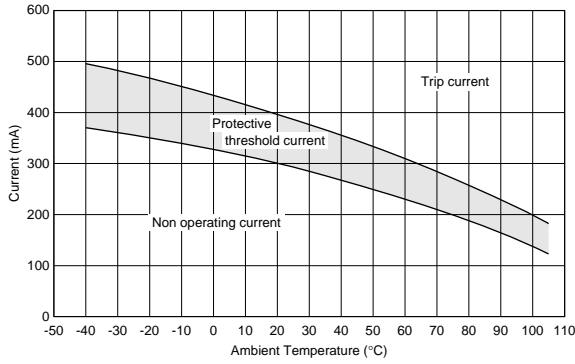

PTGL9SAS3R3K4B51B0

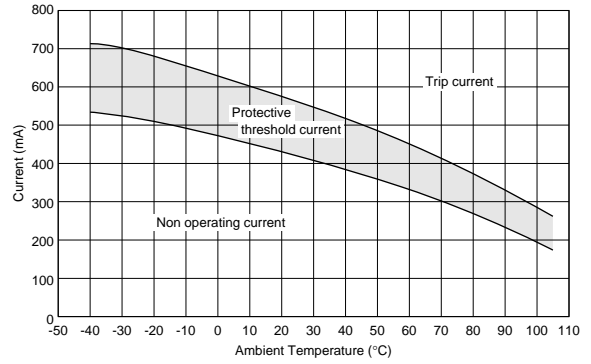

■ Protective Threshold Current Range (140V Series)

PTGLCSAS2R2K4B51B0

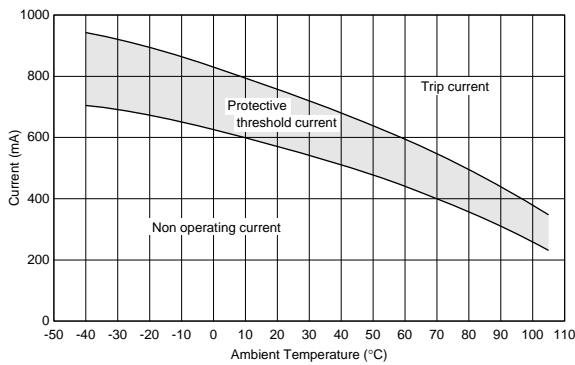

PTGL4SAS560K6B51B0

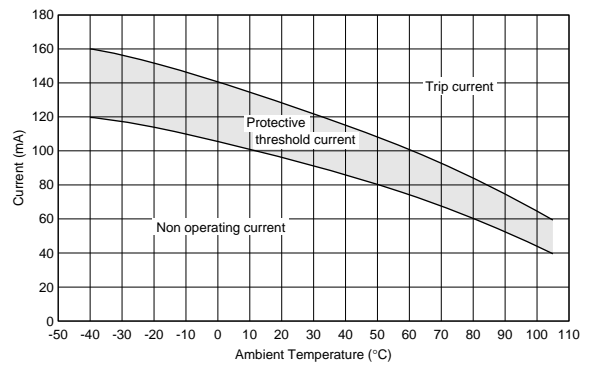

PTGL5SAS270K6B51B0

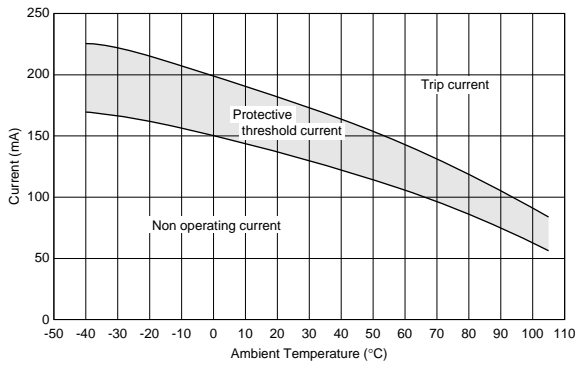

PTGL7SAS150K6B51B0

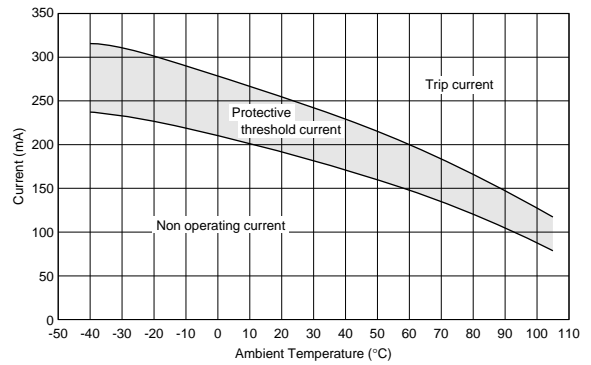

PTGL9SAS120K6B51B0

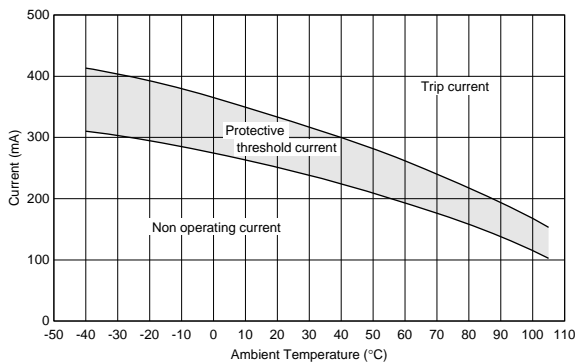

PTGL9SAS7R6K6B51B0

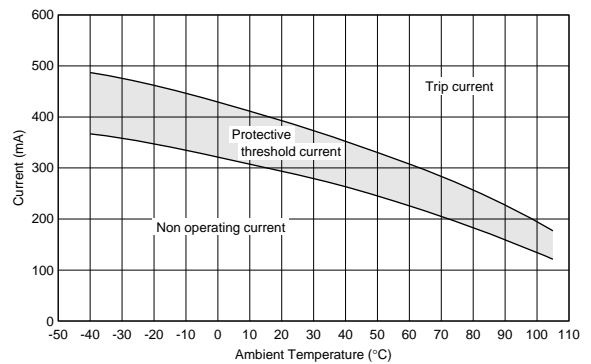

7

Continued on the following page. ↗

Continued from the preceding page.

■ Protective Threshold Current Range (140V Series)

PTGLCSAS4R7K6B51B0

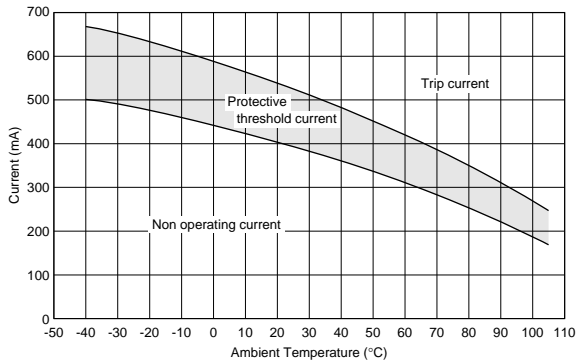

■ Operating Time (Typical Curve) (30V Series)

PTGL4SAS100K2N51B0

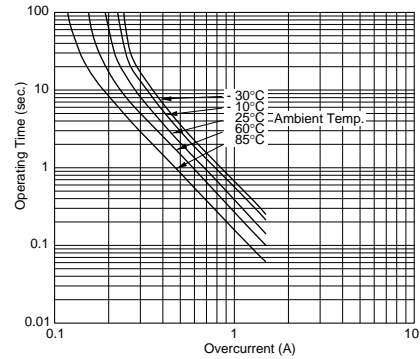

PTGL4SAS100K2B51B0

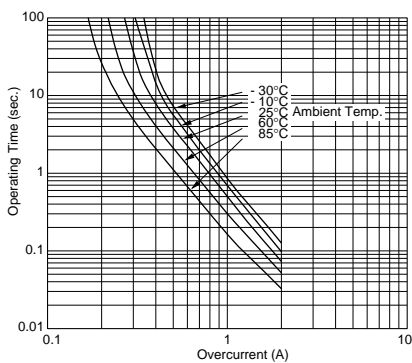

PTGL5SAS3R9K2B51B0

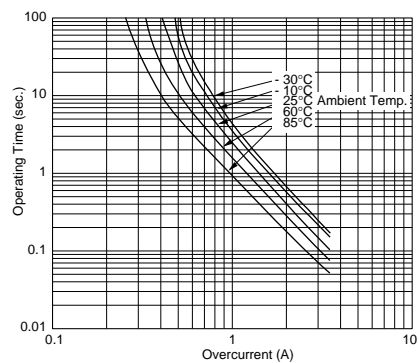

PTGL7SAS2R7K2B51B0

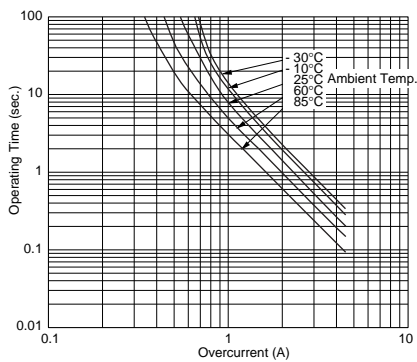

PTGL7SAS1R8K2B51B0

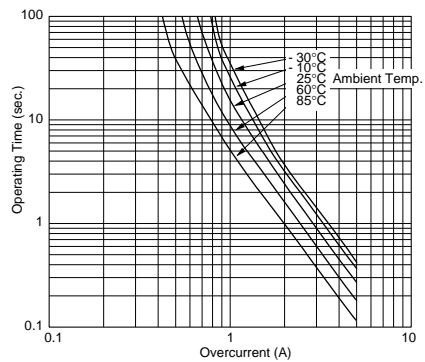

PTGL9SAS1R2K2B51B0

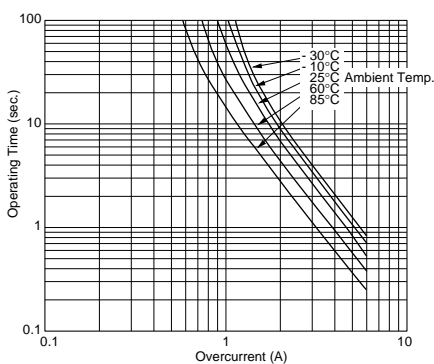

PTGLCSAS0R8K2B51B0

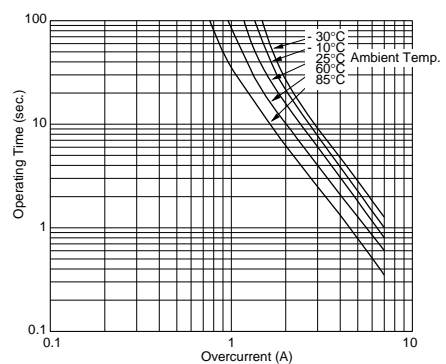

7

Continued from the preceding page.

■ Operating Time (Typical Curve) (51V Series)

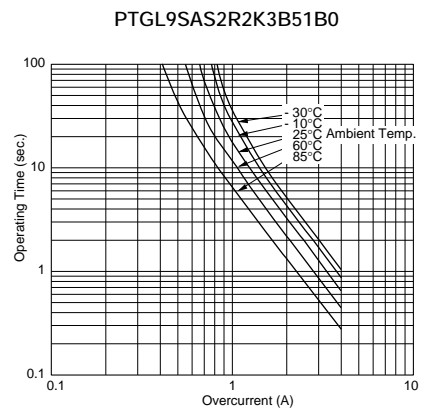
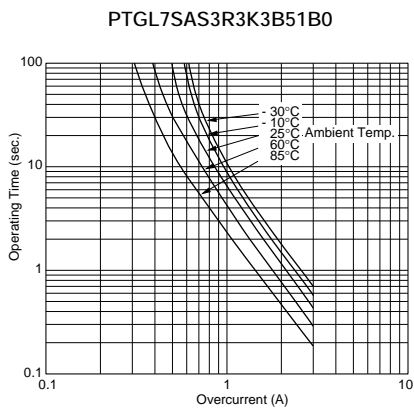
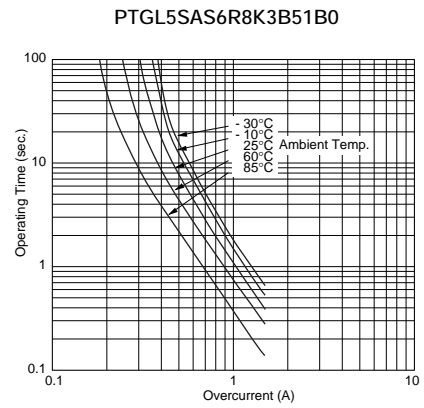
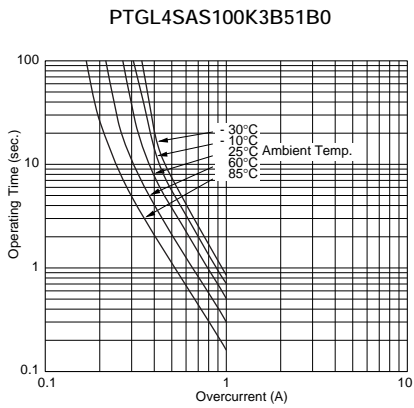

■ Operating Time (Typical Curve) (60V Series)

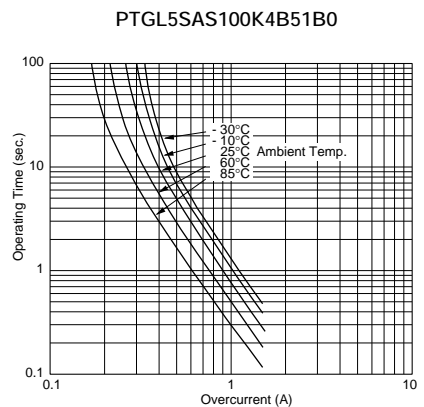
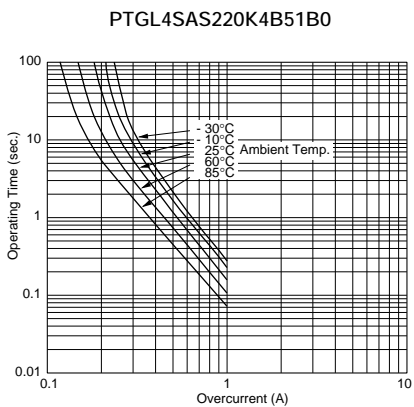
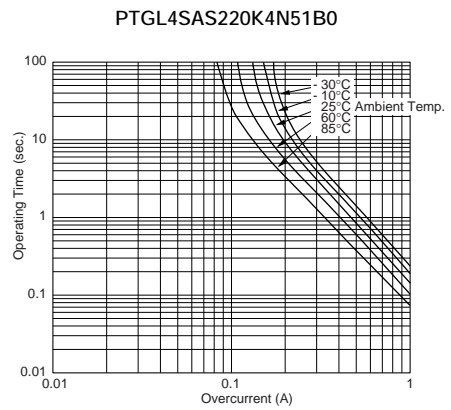
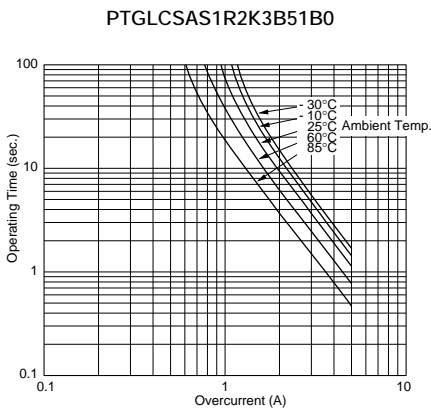

7

Continued on the following page. ↗

Continued from the preceding page.

■ Operating Time (Typical Curve) (60V Series)

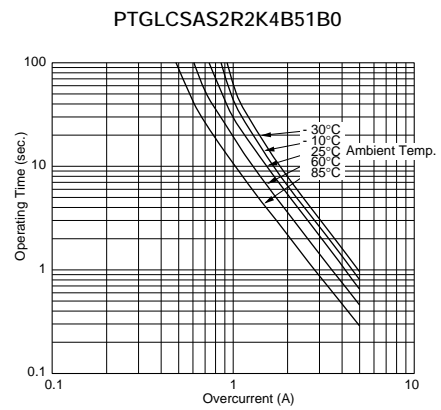
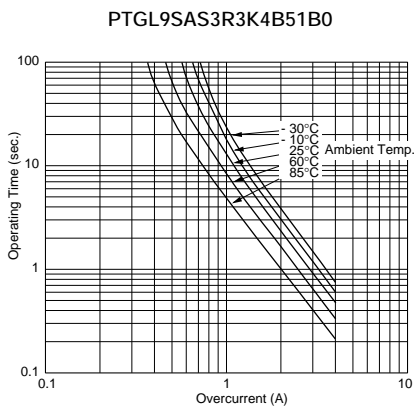
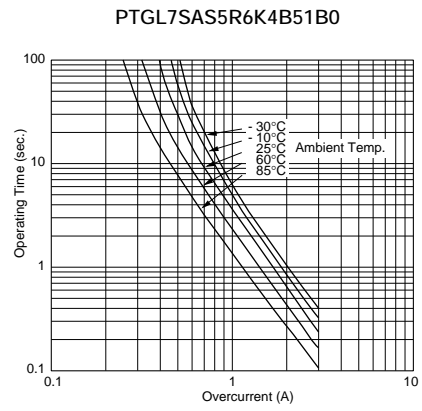
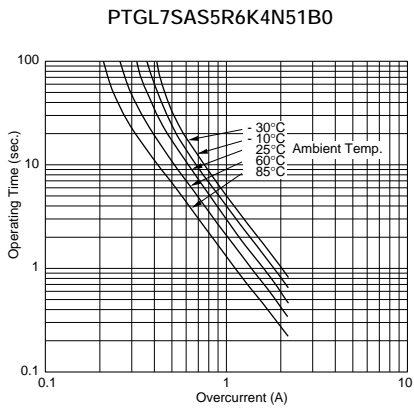

■ Operating Time (Typical Curve) (140V Series)

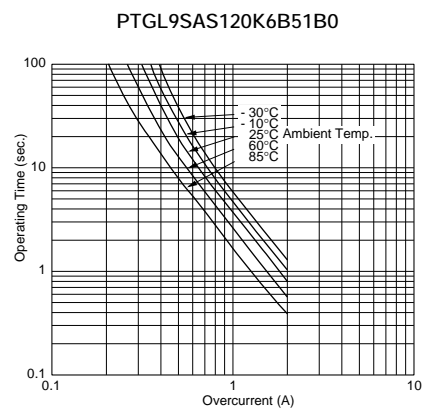
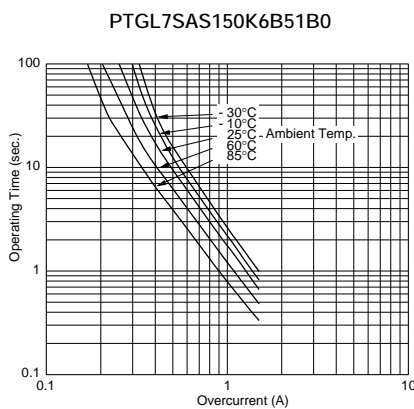
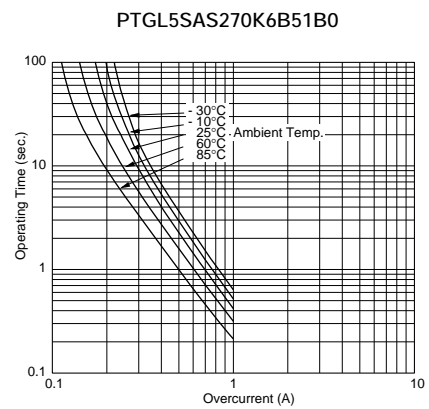
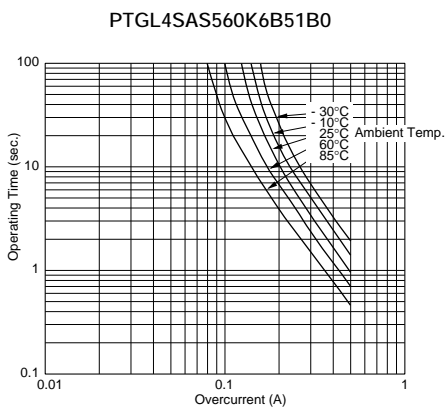

7

Continued on the following page. ↗

↳ Continued from the preceding page.

■ Operating Time (Typical Curve) (140V Series)

PTGL9SAS7R6K6B51B0

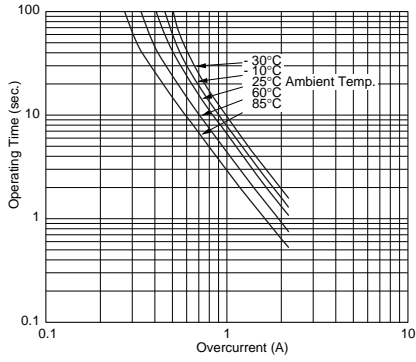

PTGLCSAS4R7K6B51B0

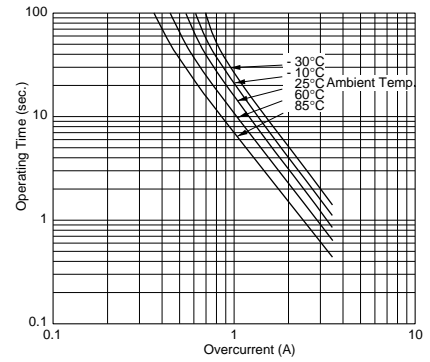

POSISTOR® Lead Type for Overheat Protection Specifications and Test Methods

| No. | Item | Rating Value | Method of Examination |
|-----|--|--|--|
| 1 | Operating Temperature 1 | -30 to +125°C | The temperature range with maximum voltage applied to the POSISTOR®. |
| 2 | Operating Temperature 2 | -40 to +125°C | The temperature range with following voltage applied to the POSISTOR®. <applied voltage> 30V and 51V series: max. 16V, 60V series: max. 30V, 140V series: max. 140V |
| 3 | Resistance (R25) | Satisfies ratings | Resistance value is measured by applying voltage under 1.0Vdc (by a direct current of less than 10mA) at 25°C. (But it must be measured after it is applied maximum voltage for 180 seconds and then is left for 2 hours at 25°C.) |
| 4 | Withstanding Voltage | No problem | We apply AC voltage 120% that of the maximum voltage to POSISTOR® by rising voltage gradually for 180±5 seconds at 25°C. (A protective resistor is to be connected in series, and the inrush current through POSISTOR® must be limited below max. rated value.) |
| 5 | Protective Threshold Current | Satisfies ratings (Trip Current, Non-operating Current) | Maximum current measured in this examination. Voltage is applied to POSISTOR® in 3 minutes step by step on still air based on "Protective Threshold Current Test Conditions" shown in next page. Stablecurrent is measured at each step. |
| 6 | Tensile Strength of Lead Wire Terminal | No damage | The load is gradually applied to each terminal of POSISTOR® until the force of 4.9N in the axial direction with fixing POSISTOR®'s body itself and this load is being kept for 10 seconds. |
| 7 | Bending Strength of Lead Wire Terminal | Lead wire does not come off | POSISTOR® is held so that it is perpendicular to the lead wire with 2.45N in the axial direction of the lead wire. The lead wire is slowly bent toward 90° and returned. Then it is slowly bent in the opposite direction and returned to original state. |
| 8 | Solderability | Solder is applied around the lead wire covering 3/4 or more of the circumference without gap in the axial direction. | The Lead wire of POSISTOR® is soaked in a Isopropyl Alcohol (JIS K 8839) solution (about 25wt%) of colophony (JIS K 5902) for 5-10 sec. And, each lead wire is soaked in Molten solder (JIS Z 3282 H60A) at 235±5°C from the bottom to a point of 2.0-2.5mm for 2±0.5 sec. |
| 9 | Terminal Durability of Soldering | $\Delta R/R25 \leq \pm 15\%$ | The lead wire of POSISTOR® is soaked in Molten solder (JIS Z 3282 H60A) at 350±10°C from the bottom to a point of 2.0-2.5mm for 3.5±0.5 sec. After the device is left at room temperature (25°C) for 24±4 hours, the resistance is measured. |
| 10 | Vibration Resistant | $\Delta R/R25 \leq \pm 20\%$ | Acceleration: 98m/s ² (10G) Width: 1.5mm Vibration: 10-500-10Hz Vibrate for 11 minutes X 24 cycles in each of 3 mutually perpendicular planes for a total of 13.5 hours. |
| 11 | Heat Resistant | $\Delta R/R25 \leq \pm 20\%$ | POSISTOR® is set in an environmental chamber at 125±3°C for 1000 hours. After the device is left at room temperature (25°C) for one hour, the resistance measurement is performed. |
| 12 | Cold Resistant | $\Delta R/R25 \leq \pm 20\%$ | POSISTOR® is set in an environmental chamber at -40±3°C for 1000 hours. After the device is left at room temperature (25°C) for one hour, the resistance measurement is performed. |
| 13 | Resistance to Damp Heat | $\Delta R/R25 \leq \pm 20\%$ | POSISTOR® is set in an environmental chamber at 85±3°C and 80-85% humidity for 1000±12 hours. After the device is left at room temperature (25°C) for one hour, the resistance measurement is performed. |

Continued on the following page. 

POSISTOR® Lead Type for Overheat Protection Specifications and Test Methods

☒ Continued from the preceding page.

■ Operating current test conditions

(1) Substrate

Materials: Phenol

Size: 50x50x1.6mm

Land Pattern: Cu land without through hole

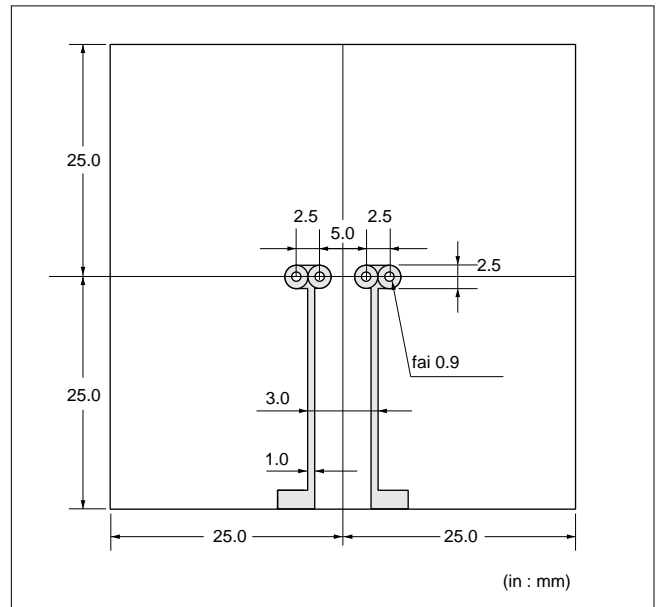

(2) Measurement condition

Solder POSISTOR® on the substrate, then put the cover (150mm cubed) surround POSISTOR® to prevent flow of wind.

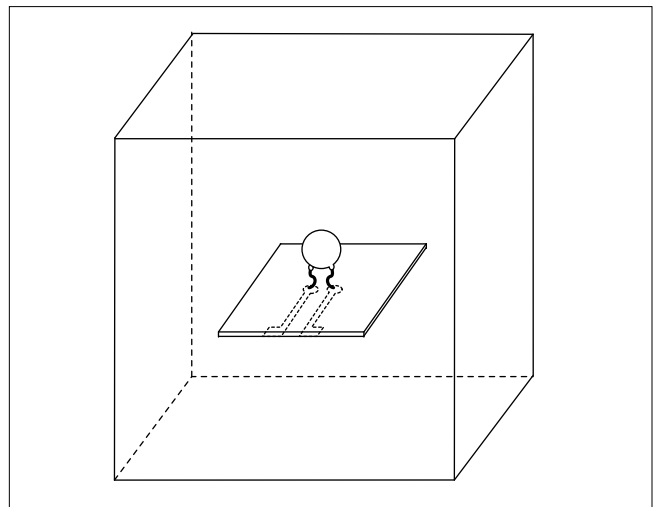

(3) Measurement circuit

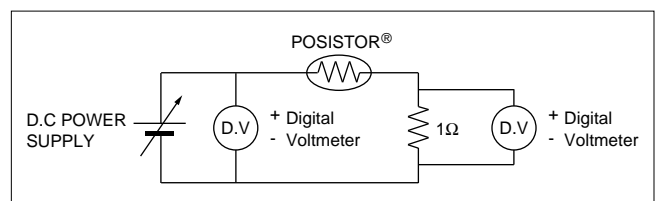

POSISTOR® Lead Type for Overheat Protection ⚠Caution/Notice

■ ⚠Caution (Storage and Operating Condition)

This product is designed for application in an ordinary environment (normal room temperature, humidity and atmospheric pressure). Do not use under the following conditions because all these factors can deteriorate the characteristics or cause product failure and burn-out.

1. Corrosive gas or deoxidizing gas (Chlorine gas, Hydrogen sulfide gas, Ammonia gas, Sulfuric acid gas, Nitric oxide gas, etc.)
2. Volatile or flammable gas
3. Dusty conditions
4. Under vacuum, or under high or low-pressure
5. Wet or humid conditions
6. Places with salt water, oils, chemical liquids or organic solvents
7. Strong vibrations
8. Other places where similar hazardous conditions exist

■ ⚠Caution (Other)

Be sure to provide an appropriate fail-safe function on your product to prevent secondary damage that may be caused by the abnormal function or the failure of our product.

■ Notice (Storage and Operating Condition)

To keep solderability of product from declining, following storage condition is recommended.

1. Storage condition:
 - Temperature -10 to +40 degree C
 - Humidity less than 75%RH (not dewing condition)
2. Storage term:
 - Use this product within 6 months after delivery by first-in and first-out stocking system.
3. Handling after unpacking:
 - After unpacking, promptly reseal this product or store it in a sealed container with a drying agent.
4. Storage place:
 - Do not store this product in corrosive gas (sulfuric acid, chlorine, etc.) or in direct sunlight.

■ Notice (Soldering and Mounting)

When the lead of this product is soldered, pay attention as follows to avoid the decline of element characteristics or break-down of the element.

1. Use Rosin type flux or non-activated flux
2. Do not dip the body into flux.
(Flux should be coated to lead wire only for soldering.)
3. Be sure that preheating does not melt the soldering of this product.

■ Notice (Handling)

1. Do not apply an excessive force to the lead.
Otherwise, it may cause the junction between lead and element to break, or may crack the element. Therefore, holding the element side lead wire is recommended when lead wire is bent or cut.
2. This product does not have waterproof construction. Splashed water may cause failure mode such as decline of characteristics or current leak.
3. When this product is operated, temperature of some area may be over 100 to 160 degree C. Be sure that surrounding parts and inserting material can withstand the temperature. If the surrounding part and material are kept under such condition, they may deteriorate or produce harmful gas (Chlorine gas, Hydrogen sulfide gas, Ammonia gas, Sulfuric acid gas, Nitric oxide gas, etc.). And such harmful gas may deteriorate the element.

for NTC Thermistors Chip Type Package

■ Minimum Quantity Guide

| Part Number | Quantity (pcs.) | |
|--------------|-----------------|--------------|
| | Paper Tape | Plastic Tape |
| NCP15 | 10000 | - |
| NCP18 | 4000 | - |
| NCM21 | - | 4000 |

■ Tape Carrier Packaging

1. Dimensions of Reel

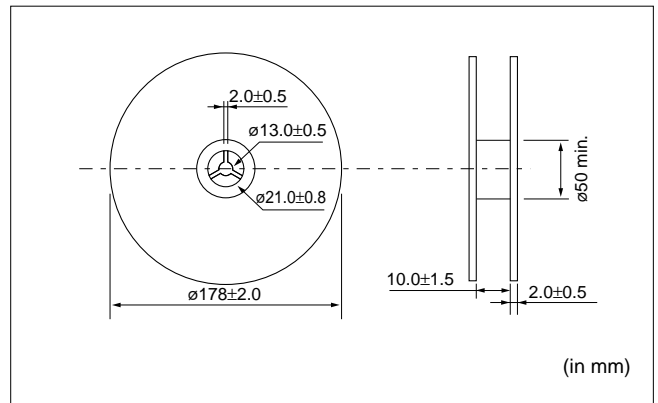

2. Taping Method

- (1) A tape in a reel contains Leader unit and Trailer unit where products are not packed. (Please refer to the figure at right.)
- (2) The top and base tapes or, plastic and cover tape are not stuck at the first five pitches minimum.
- (3) A label shall be attached on the reel. (MURATA's part number, inspection number and quantity should be marked on the label.)
- (4) Taping reels are packed in a package.

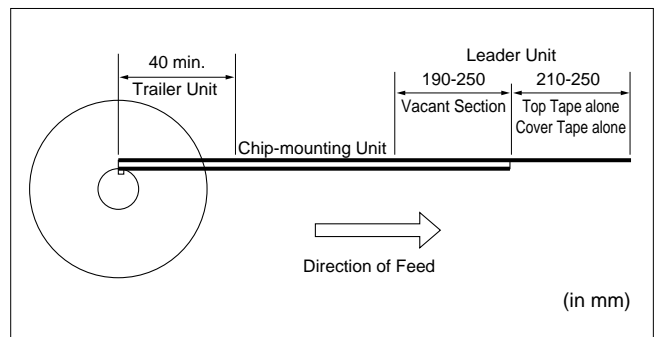

Continued on the following page.

for NTC Thermistors Chip Type Package

☐ Continued from the preceding page.

3. Paper Tape (NCP15/18 Series)

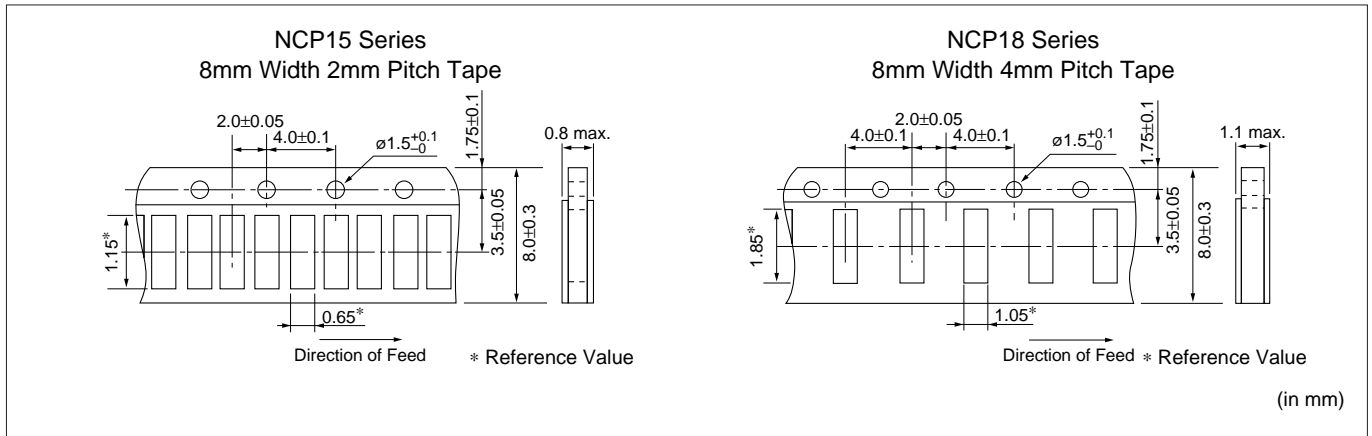

(1) Other Conditions

① Packaging

Products are packaged in the cavity of the base tape and sealed by top tape and bottom tape.

② Tape

Top tape and bottom tape have no joints and products are packaged and sealed in the cavity of the base tape, continuously.

(2) Peeling Force of Top Tape

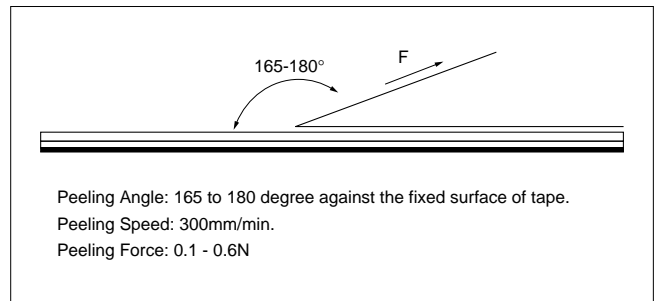

(3) Pull Strength

Pull strength of top tape is specified at 10N minimum.

Pull strength of bottom tape shall be specified 5N minimum.

Continued on the following page. ☐

for NTC Thermistors Chip Type Package

☐ Continued from the preceding page.

4. Plastic Tape (NCM21 Series)

(1) Other Conditions

① Packaging

Products are packaged in the each embossed cavity of plastic tape and sealed by cover tape.

② Tape

Cover tape has no joints.

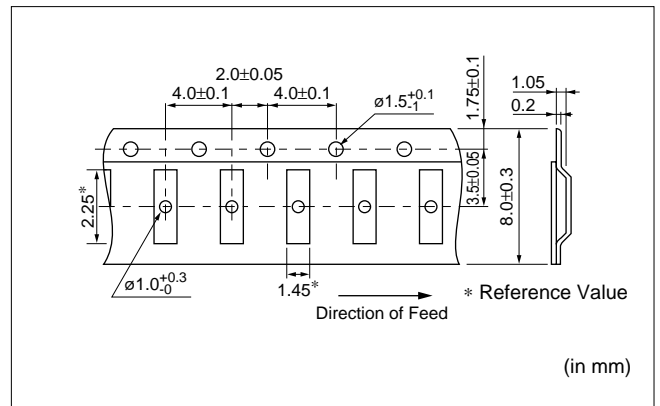

(2) Peeling Force of Cover Tape

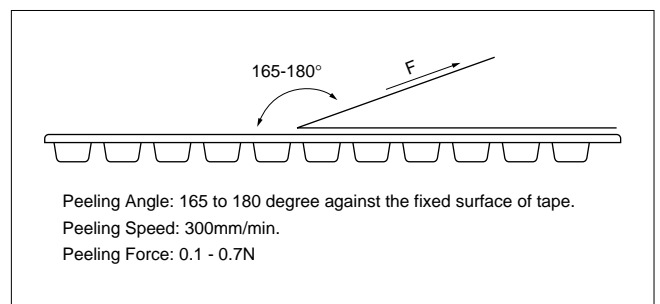

(3) Tape Strength

Pull strength of plastic tape and cover tape shall be specified 10N minimum.

for NTC Thermistors Lead Type Package

■ Minimum Quantity Guide

| Part Number | Minimum Quantity (pcs.) | |
|-------------|-------------------------|------|
| | Taping (Ammo Pack) | Bulk |
| NTSS | 3000 | 100 |

■ Taping Dimension (NTSS_N6A0 Series)

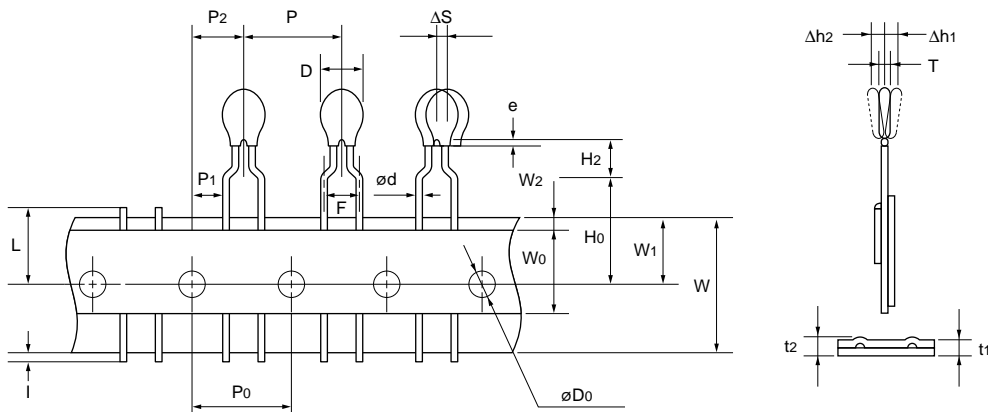

| Item | Code | Dimension (mm) |
|---|----------|-----------------------|
| Pitch of Component | P | 12.7 |
| Pitch of Sprocket Hole | P0 | 12.7±0.3 |
| Lead Spacing | F | 5.0+0.8/-0.2 |
| Lead Length from Hole Center to Component Center | P2 | 6.35±1.3 |
| Lead Length from Hole Center to Lead | P1 | 3.85±0.8 |
| Body Diameter | D | 3.5 max. |
| Deviation along Tape, Left or Right | ΔS | 0±2.0 |
| Carrier Tape Width | W | 18.0±0.5 |
| Position of Sprocket Hole | W1 | 9.0±0.5 |
| Lead Distance between Reference and Bottom Planes | H0 | 16.0±1.0 |
| Height of Component | H2 | 4.0 max. |
| Overflow of Lead | I | +0.5 to -1.0 |
| Diameter of Sprocket Hole | D0 | 4.0±0.1 |
| Lead Diameter | d | 0.50±0.03 |
| Total Tape Thickness | t1 | 0.6±0.3 |
| Total Thickness, Tape and Lead Wire | t2 | 1.6 max. |
| Deviation across Tape | Δh1, Δh2 | 1.0 max. |
| Portion to Cut in Case of Defect | L | 11.0+0/-2.0 |
| Hole Down Tape Width | W0 | 11.0 min. |
| Hole Down Tape Position | W2 | 1.5±1.5 |
| Coating Extension on Lead | e | Up to the crimp point |
| Thickness | T | 2.6 max. |

(in mm)

for POSISTOR[®] Chip Type Package

■ Minimum Quantity Guide

| Part Number | Quantity (pcs.) | |
|-------------|-----------------|--------------|
| | Paper Tape | Plastic Tape |
| PR*18_RB | 4000 | - |
| PR*21_RA | - | 4000 |
| PR*21_RK | - | 3000 |

■ Tape Dimensions

PR*18_RB Series: Paper Tape

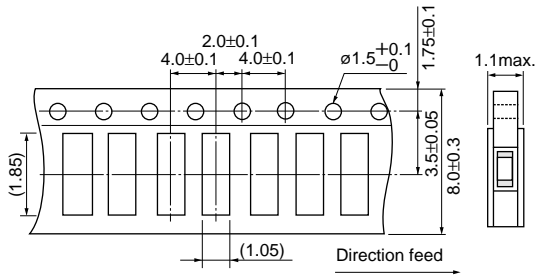

PR*21_RA Series: Plastic Tape

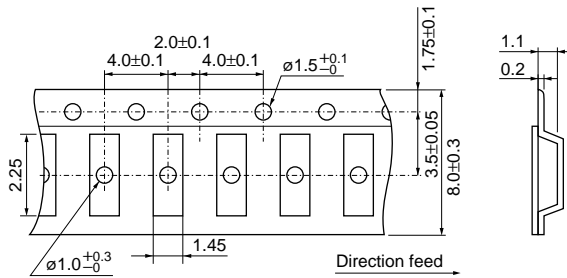

PR*21_RK Series: Plastic Tape

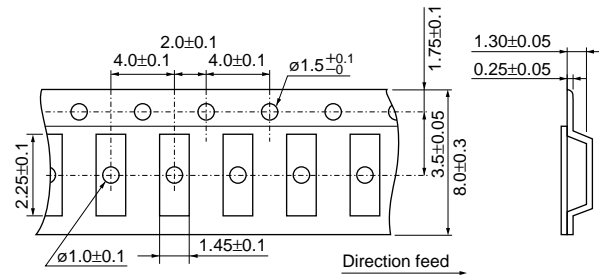

■ Reel Dimensions

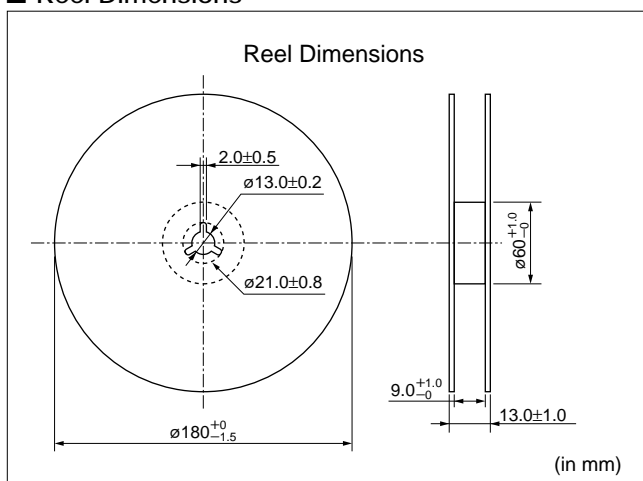

for POSISTOR[®] Lead Type Package

■ Minimum Quantity Guide

| Part Number | Minimum Quantity (pcs.) | |
|-------------|-------------------------|------|
| | Taping (Ammo Pack) | Bulk |
| PTGL | 1500 | 100 |

■ Taping Dimension (PTGL_A0 Series)

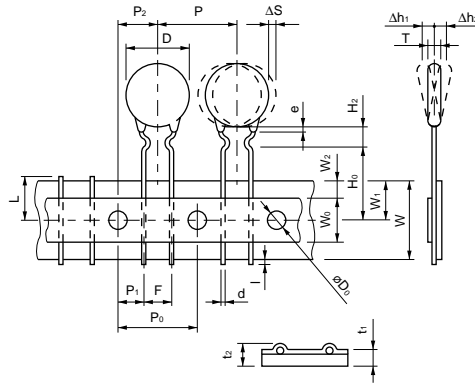

| Item | Code | Dimensions (mm) | Note |
|---|-----------------------------------|--------------------------------------|---|
| Pitch of Component | P | 12.7 | Tolerance is determined by ΔS. |
| Pitch of Sprocket Hole | P ₀ | 12.7±0.3 | |
| Lead Spacing | F | 5.0 ^{+0.8} _{-0.3} | |
| Length from Hole Center to Lead | P ₁ | 3.85±0.8 | |
| Length from Hole Center to Component | P ₂ | 6.35±1.3 | Deviation in the feeding direction |
| Body Diameter | D | Please see in Ratings | |
| Thickness | T | Please see in Ratings | |
| Deviation along Tape, Left or Right | ΔS | ±1.5 | Including the inclination caused by lead bending. |
| Carrier Tape Width | W | 18.0±0.5 | |
| Position of Sprocket Hole | W ₁ | 9.0 ^{+0.5} _{-0.75} | Deviation of tape width. |
| Lead Distance between Reference and Bottom Planes | H ₀ | 16.0±1.0 | |
| | H ₂ | 6.0 max. | |
| Overflow of Lead | l | +0.5 — -1.0 | |
| Diameter of Sprocket Hole | D ₀ | 4.0±0.2 | |
| Lead Diameter | d | Please see in Ratings | |
| Total Tape Thickness | t ₁ | 0.6±0.3 | |
| | t ₂ | 2.0 max. | |
| Deviation across Tape | Δh ₁ , Δh ₂ | 1.5 max. | |
| Portion to cut in Case of Defect | L | 11.0 ⁺⁰ _{-2.0} | |
| Hold Down Tape Width | W ₀ | 11.0 min. | |
| Hold Down Tape Position | W ₂ | 4.0 max. | |
| Coating Extension on Lead | e | Up to the center of crimp | |

⚠Note:

1. Export Control

⟨For customers outside Japan⟩

Murata products should not be used or sold for use in the development, production, stockpiling or utilization of any conventional weapons or mass-destructive weapons (nuclear weapons, chemical or biological weapons, or missiles), or any other weapons.

⟨For customers in Japan⟩

For products which are controlled items subject to the "Foreign Exchange and Foreign Trade Law" of Japan, the export license specified by the law is required for export.

2. Please contact our sales representatives or product engineers before using the products in this catalog for the applications listed below, which require especially high reliability for the prevention of defects which might directly damage to a third party's life, body or property, or when one of our products is intended for use in applications other than those specified in this catalog.

- | | |
|-----------------------------|---|
| ① Aircraft equipment | ② Aerospace equipment |
| ③ Undersea equipment | ④ Power plant equipment |
| ⑤ Medical equipment | ⑥ Transportation equipment (vehicles, trains, ships, etc.) |
| ⑦ Traffic signal equipment | ⑧ Disaster prevention / crime prevention equipment |
| ⑨ Data-processing equipment | ⑩ Application of similar complexity and/or reliability requirements to the applications listed in the above |

3. Product specifications in this catalog are as of November 2004. They are subject to change or our products in it may be discontinued without advance notice. Please check with our sales representatives or product engineers before ordering. If there are any questions, please contact our sales representatives or product engineers.

4. Please read rating and ⚠CAUTION (for storage, operating, rating, soldering, mounting and handling) in this catalog to prevent smoking and/or burning, etc.

5. This catalog has only typical specifications because there is no space for detailed specifications. Therefore, please approve our product specifications or transact the approval sheet for product specifications before ordering.

6. Please note that unless otherwise specified, we shall assume no responsibility whatsoever for any conflict or dispute that may occur in connection with the effect of our and/or a third party's intellectual property rights and other related rights in consideration of your use of our products and/or information described or contained in our catalogs. In this connection, no representation shall be made to the effect that any third parties are authorized to use the rights mentioned above under licenses without our consent.

7. No ozone depleting substances (ODS) under the Montreal Protocol are used in our manufacturing process.