

Datasheet.Directory

Microcontrollers

Quarter 3, 2005
SG1006Q32005 Rev 0

About This Revision—Q3/2005

When new products are introduced, a summary of new products will be provided in this section. However, the New Product section will only appear on this page when new products have been introduced during the quarter.

In addition, a change bar appears in the left margin of every page in this selector guide that contains new or revised information.

If products are discontinued, a What's EOL? page is included at the end of this guide. The What's EOL? page lists end-of-life products along with their respective last order date, last ship date, and suggested possible replacement information.

NEW PRODUCT

Related Product	Page Number	Table Title	Description
MCF5207	SG1006-20	MCF5xxx Family	Entry Level, Low Cost, 32-Bit Embedded Coldfire Microprocessor with Connectivity Option.
MCF5208	SG1006-20	MCF5xxx Family	Entry Level, Low Cost, 32-Bit Embedded Coldfire Microprocessor with Connectivity Option.
MCF5211	SG1006-20	MCF5xxx Family	Entry Level, Low Cost, 32-Bit Flash-Based Single Chip Coldfire Microcontroller.
MCF5212	SG1006-20	MCF5xxx Family	Entry Level, Low Cost, 32-Bit Flash-Based Single Chip Coldfire Microcontroller
MCF5213	SG1006-20	MCF5xxx Family	Entry Level, Low Cost, 32-Bit Flash-Based Single Chip Coldfire Microcontroller
MCF8013	SG1006-27	56800E Family	16-Bit Digital Signal Controller
MCF8014	SG1006-27	56800E Family	16-Bit Digital Signal Controller
MC56F8135	SG1006-28	56800E Family	16-Bit Digital Signal Controller
MC56F8335	SG1006-25	56800E Family	16-Bit Digital Signal Controller

68HC08 FAMILY

68HC08 Product Table

For complete part number information and temperature definitions, refer to "Product Numbering System for 68HC08" on page SG1006-9.

Product	ROM (KB)	RAM (Bytes)	Flash or OTP (KB)	EEPROM (Bytes)	Timer	I/O	Serial	MUX	A/D	PWM	COP	Operating Voltage (V)	Max Bus Freq (MHz)	Temp	Packaging	OTP or Flash Equiv.	Status	Additional Information	Documentation
HC08AB Family—Embedded E²																			
MC68HC08AB16A	16	512	n/a	512	4-CH + 4-CH, 16-bit IC, OC, or PWM	51	SCI SPI	n/a	8-CH, 8-bit	See Timer	Y	5.0	8.0	C, M	64-pin QFP (FU)	908AB32	Available	Programmable interrupt timer module	MC68HC08AB16A
MC68HC908AB32	n/a	1K	32 Flash													C, V, M			n/a
HC08AS/AZ Family—Automotive/Industrial Communication Protocols J1850/CAN																			
MC68HC08AS32A	32	1K	n/a	512	6-CH, 16-bit IC, OC, or PWM	Up to 46	SCI SPI	n/a	15-CH, 8-bit	See Timer	Y	5.0	8.0	C, V, M	52-Pin PLCC (FN) 64-Pin QFP (FU)	908AS60A	Available	www.freescale.com	MC68HC08AS32A
HC08AP Family—General Purpose 10-bit A/D, I²C, Pin Compatible from 8-60K Flash																			
MC68HC908AP8	n/a	1K	8 Flash	n/a	Dual 2-CH, 16-bit IC, OC or PWM	Up to 32	I ² C 2 SCI SPI	n/a	8-CH, 10-bit	See Timer	Y	3.0, 5.0	8.0	C	42-pin SDIP (B) 44-pin QFP (FB) 48-pin LQFP (FA)	n/a	Available	32-kHz PLL, RC oscillator option, timebase module, low-voltage inhibit, up to 8 keyboard interrupts, 6 open-drain pins with 25 mA sink	MC68HC908AP64
MC68HC908AP16			16 Flash																
MC68HC908AP32		2K	32 Flash																
MC68HC908AP64			62 Flash																
HC08BD Family—Digital Monitors																			
MC68HC08BD24	24	512	n/a	n/a	2-CH, 16-bit IC, OC, or PWM	32	I ² C DDC12AB	n/a	6-CH, 8-bit	16-CH, 8-bit	Y	5.0	6.0	I	42-pin SDIP (B) 44-pin QFP (FB)	908BD48	Available	For use in digital monitor systems; sync signal processor	MC68HC08BD24
MC68HC908BD48	n/a	1024	48 Flash												42-pin SDIP (B) 44-pin QFP (FB) 28-pin DIP (P)	n/a			MC68HC908BD48

68HC08 FAMILY

68HC08 FAMILY (continued) 68HC08 Product Table (continued)

For complete part number information and temperature definitions, refer to "Product Numbering System for 68HC08" on page SG1006-9.

Product	ROM (KB)	RAM (Bytes)	Flash or OTP (KB)	EEPROM (Bytes)	Timer	I/O	Serial	MUX	A/D	PWM	COP	Operating Voltage (V)	Max Bus Freq (MHz)	Temp	Packaging	OTP or Flash Equiv.	Status	Additional Information	Documentation
HC08EY Family—Automotive/Industrial LIN																			
MC68HC908EY16	n/a	512	16 Flash	n/a	2-CH + 2-CH, 16-bit IC, O/C, or PWM	24	ESCI SPI	n/a	8-CH, 10-bit	See Timer	Y	5.0	8.0	C, V, M	32-pin LQFP (FA)	n/a	Production	First product of the MC68HC908EYx Family for LIN and general market	MC68HC908EY16
HC08G Family—General Purpose																			
MC68HC908GP32	n/a	512	32 Flash	n/a	Dual 2-CH, 16-bit IC, OC, or PWM	33	SCI SPI	n/a	8-CH, 8-bit	See Timer	Y	3.0, 5.0	8.0	C	40-pin DIP (P) 44-pin QFP (FB) 42-pin SDIP (B)	n/a	Available	32-kHz PLL, timebase module, low-voltage inhibit with selectable trip points	MC68HC908GP32
MC68HC908GP32A	32		n/a											C, V, M	44-pin QFP (FB) 42-pin SDIP (B)	908GP32			
MC68HC908GR4	n/a	384	4 Flash	n/a	2-CH + 1-CH, 16-bit IC, OC, or PWM	21	SCI SPI	n/a	6-CH, 8-bit	See Timer	Y	3.0, 5.0	8.0	C	28-pin DIP (P) 32-pin LQFP (FA) 28-pin SOIC (DW)	n/a	Available	28-/32-pin 4K Flash version of the 908GP32. 32-kHz PLL, timebase module, all pins 10 mA, programmable pull-ups on all I/O, extra 2-CH A/D in 32 QFP	MC68HC908GR8
MC68HC908GR8			7.5 Flash						4-CH, 8-bit									28-/32-pin 8K Flash version of 908GP32, has timebase module	
MC68HC908GR16	n/a	1K	16 Flash	n/a	Dual 2-CH, 16-bit IC, OC, or PWM	Up to 37	ESCI SPI	n/a	6-CH, 10-bit	See Timer	Y	3.0, 5.0	8.0	C, V, M	32-pin LQFP (FJ) 48-pin LQFP (FA)	n/a	Available	www.freescale.com	MC68HC908GZ16
MC68HC908GR32A		32 Flash	24-CH, 10-bit						1 to 8 MHz high frequency oscillator. When ordering, request MC908GR32Axxx										
MC68HC908GR48A	n/a	1.5 K	48 Flash	n/a	2-CH + 6-CH, 16-bit IC, OC, or PWM	Up to 50	ESCI SPI	n/a	24-CH, 10-bit	See Timer	Y	3.0, 5.0	8.0	C, V, M	32-pin LQFP (FJ) 48-pin LQFP (FA) 64-pin QFP (FU)	n/a	Available	1 to 8 MHz high frequency oscillator. When ordering, request MC908GR48Axxx	MC68HC908GR60A
MC68HC908GR60A		2K	60 Flash															1 to 8 MHz high frequency oscillator. When ordering, request MC908GR60Axxx	
MC68HC908GT8	n/a	512	8 Flash	n/a	Dual 2-CH, 16-bit IC, OC, or PWM	36	SCI SPI	n/a	8-CH, 8-bit	See Timer	Y	3.0, 5.0	8.0	C	44-pin QFP (FB) 42-pin SDIP (B)	n/a	Available	Internal clock generator, timebase module, low-voltage inhibit with selectable trip points	MC68HC908GT16
MC68HC908GT16			16 Flash																

A change bar appears in the left margin to mark the location of new or revised information.

68HC08 FAMILY (continued)

68HC08 Product Table (continued)

For complete part number information and temperature definitions, refer to "Product Numbering System for 68HC08" on page SG1006-9.

Product	ROM (KB)	RAM (Bytes)	Flash or OTP (KB)	EEPROM (Bytes)	Timer	I/O	Serial	MUX	A/D	PWM	COP	Operating Voltage (V)	Max Bus Freq (MHz)	Temp	Packaging	OTP or Flash Equiv.	Status	Additional Information	Documentation				
HC08GZ Family—Low Cost CAN																							
MC68HC908GZ8	n/a	1K	8 Flash	n/a	Dual 2-CH, 16-bit IC, OC, or PWM	Up to 37	ESCI SPI	n/a	8-CH, 10-bit	See Timer	Y	3.0, 5.0	8.0	C, V, M	32-pin QFP (FJ) 48-pin LQFP (FA)	n/a	Available	MSCAN 2.0	MC68HC908GZ16				
MC68HC908GZ16			16 Flash															2-CH + 6-CH, 16-bit IC, OC, or PWM	Up to 50	1 CAN	24-CH, 10-bit	32-pin LQFP (FJ) 48-pin LQFP (FA) 64-pin QFP (FU)	1 to 8 MHz high frequency oscillator. When ordering, request MC908GZ32xxx.
MC68HC908GZ32		32 Flash	1 to 8 MHz high frequency oscillator. When ordering, request MC908GZ48xxx.																				
MC68HC908GZ48		48 Flash	1 to 8 MHz high frequency oscillator. When ordering, request MC908GZ60xxx.																				
MC68HC908GZ60	2K	60 Flash	60 Flash																				
HC08JB/JT Family—Low Cost USB																							
MC68HC08JB1	5.5	128	n/a	n/a	2-CH, 16-bit IC, OC, or PWM	13	USB PS/2	n/a	n/a	See Timer	Y	5.0	3.0	B only	20-pin DIP (P) 20-pin SOIC (JDW)	908JB8	Available	Supports both USB and PS/2; 1.5 Mbps USB with 2 endpoints, low-voltage reset, keyboard interrupt, 3.3 V bandgap reference	MC68HC08JB1				
MC68HC908JB8	n/a	256	8 Flash			Up to 37	USB								n/a	n/a		20-pin DIP (P) 28-pin SOIC (DW) 44-pin QFP (FB) 20-pin SOIC (JDW)	n/a	Complies with USB 1.1 specification for low-speed USB (1.5 Mbps), On-chip 3.3 V regulator	MC68HC908JB8		
MC68HC08JB8A	8		n/a		20-pin PDIP (JP) 20-pin SOIC (JDW) 28-pin SOIC (ADW) 44-pin QFP (FB)														908JB8			Complies with USB 1.1 specification for low-speed USB (1.5 Mbps), LVI	
MC68HC908JB12	n/a	384	12 Flash		Dual 2-CH, 16-bit IC, OC, or PWM	Up to 21	SCI USB								n/a	n/a		See Timer	Y	4.0 to 5.5	6.0	B only	20-pin SOIC (JDW) 28-pin SOIC (DW)
MC68HC908JB16			16 Flash	32-pin LQFP (FA) 28-pin SOIC (DW) 20-pin SOIC (JDW)																			
MC68HC08JT8	8	256	n/a	2-CH, 16-bit IC, OC, or PWM	Up to 37	n/a					2.0 to 3.6	3.0		20-pin PDIP (JP) 20-pin SOIC (JDW) 28-pin SOIC (ADW) 44-pin QFP (FB)							www.freescale.com	MC68HC908JB8	

68HC08 FAMILY

68HC08 FAMILY (continued) 68HC08 Product Table (continued)

For complete part number information and temperature definitions, refer to "Product Numbering System for 68HC08" on page SG1006-9.

Product	ROM (KB)	RAM (Bytes)	Flash or OTP (KB)	EEPROM (Bytes)	Timer	I/O	Serial	MUX	A/D	PWM	COP	Operating Voltage (V)	Max Bus Freq (MHz)	Temp	Packaging	OTP or Flash Equiv.	Status	Additional Information	Documentation
HC08JK/JL Family—Low Cost, Pin Compatible, and Migratable with A/D																			
MC68HC908JK1E	n/a	128	1.5 Flash	n/a	2-CH, 16-bit IC, OC, or PWM	15	n/a	n/a	12-CH, 8-bit	See Timer	Y	3.0, 5.0	8.0	C, M	20-pin DIP (P) 20-pin SOIC (DW)	n/a	Available	RC oscillator option, LVR with selectable trip points, 6-pin LED drive	MC68HC908JL3
MC68HC908JK8		8 Flash	Dual 2-CH, 16-bit IC, OC, or PWM		14	SCI	14-CH, 8-bit		20-pin PDIP (P) 20-pin SOIC (DW)						RC oscillator option, programmable LVI			MC68HC908JL8	
MC68HC908JL8		256	Dual 2-CH, 16-bit IC, OC, or PWM		Up to 26	SCI	14-CH, 8-bit		28-pin PDIP (P) 28-pin SOIC (DW) 32-pin LQFP (FA)						RC oscillator option. Programmable LVI			MC68HC908JL8	
MC68HC08JL8		8	n/a		Dual 2-CH, 16-bit IC, OC, or PWM	Up to 26	SCI		14-CH, 8-bit						28-pin PDIP (P) 28-pin SOIC (DW) 32-pin LQFP (FA)			RC oscillator option. Programmable LVI	MC68HC908JL8
HC08KX Family—Low Pin Count with ICG																			
MC68HC908KX2	n/a	192	2 Flash	n/a	2-CH, 16-bit IC, OC, or PWM	13	SCI	n/a	4-CH, 8-bit	See Timer	Y	3.0, 5.0	8.0	C, V, M	16-pin DIP (P) 16-pin SOIC (DW)	n/a	Available	Internal clock generator (ICG)	MC68HC908KX8
MC68HC908KX8			8 Flash															Internal clock generator (ICG) DW	
HC08LB Family—PWM for Half Bridge Control Power Factor Correction																			
MC68HC908LB8	n/a	128	8K Flash	n/a	2-CH, 16-bit 1-CH IC, OC, or PWM	Up to 18	n/a	n/a	7-CH, 8-bit	See Timer +2-CH, 11-bit, +2-CH, 12-bit	Y	5.0	8.0	C, V, M	20-pin PDIP (P) 20-pin SOIC (DW)	n/a	Available	PWM for half bridge control & PFC Trimmable Internal Osc On board Op-Amp Analog Comparator Low Voltage Warning	MC68HC908LB8
HC08LD Family—Digital Monitoring																			
MC68HC908LD60	n/a	1K	60 Flash	n/a	2-CH, 16-bit IC, OC, or PWM	39	I ² C, DDC12A	n/a	6-CH, 8-bit	8-CH, 8-bit	Y	3.3	6.0	I	64-pin QFP (FU)	n/a	Available	For use in digital monitor systems	MC68HC908LD60
MC68HC908LD64		2K																I ² C, DDC12A BUSB w/ hub	For use in digital monitor systems. USB 1.1, composite hub w/ embedded functions. Sync signal processor, on-screen display (OSD) module

68HC08 FAMILY (continued)
68HC08 Product Table (continued)

For complete part number information and temperature definitions, refer to "Product Numbering System for 68HC08" on page SG1006-9.

Product	ROM (KB)	RAM (Bytes)	Flash or OTP (KB)	EEPROM (Bytes)	Timer	I/O	Serial	MUX	A/D	PWM	COP	Operating Voltage (V)	Max Bus Freq (MHz)	Temp	Packaging	OTP or Flash Equiv.	Status	Additional Information	Documentation
HC08LJ/LK Family—Low Cost LCD																			
MC68HC08LJ12	12	512	n/a	n/a	Dual 2-CH, 16-bit IC, OC or PWM	Up to 32	SCI SPI	n/a	Up to 6-CH, 10-bit	See Timer	Y	3.3, 5.0	8.0	C	64-pin QFP (FU) 64-pin LQFP (PB) 52-pin LQFP (FB)	n/a	Available	LCD driver module: 4/3 backplanes with maximum 26 frontplanes, real time clock, IR modulation/demodulation, up to 8 keyboard interrupts, up to 6 pins with high sink capability	MC68HC908LJ12
MC68HC908LJ12	n/a		12 Flash															LCD driver module: 4/3 backplanes with maximum 26 front planes, Real-time clock, IR modulation/demodulation	
MC68HC908LJ24		768	24 Flash	n/a	Dual 2-CH, 16-bit IC, OC or PWM	Up to 48	SCI SPI i ² C	n/a	Up to 6-CH, 10-bit	See Timer	Y	3.3, 5.0	8.0	C	64-pin QFP (FU) 80-pin LQFP (PK) 64-pin LQFP (PB)	n/a	Available	LCD driver module: 4/3 backplanes with maximum 33 front planes, real time clock, IR modulation/demodulation, 8 keyboard interrupts, 30 pins with 15µA sink capability	MC68HC908LJ24
MC68HC908LK24	n/a																	IrSCI SPI i ² C	
HC08MR Family—Motor Control																			
MC68HC908MR8	n/a	256	8 Flash	n/a	2-CH + 2-CH, 16-bit IC, OC, or PWM	14	SCI	n/a	4- to 7-CH, 10-bit	6-CH, 12-bit	Y	5.0	8.0	C, V, M	32-pin LQFP (FA) 28-pin PDIP (P) 28-pin SOIC (DW)	n/a	Available	www.freescale.com	MC68HC908MR8
MC68HC908MR16		16 Flash	4-CH + 2-CH, 16-bit IC, OC, or PWM		44	SCI SPI	10-CH, 10-bit		See Timer + 6-CH, 12-bit	64-pin QFP (FU) 56-pin SDIP (B)					PWM for 3-phase motor control			MC68HC908MR32	
MC68HC908MR32		768																	32 Flash
HC08QL Family—Low Cost LIN																			
MC908QL4	n/a	128	4	n/a	2-CH, 16-Bit IC, OC or PWM	13	n/a	SLIC (LIN)	6-CH, 10-bit	See Timer	Y	3.0 to 5.0	8	C, V, M	16-pin TSSOP (DT) 16-pin SOIC (DW)	n/a	Available	SLIC (Slave-LIN Interface Controller featuring Autobauding/Auto Synchronization	MC68HC908QL4
MC908QL3			2					MC68HC908QL4											
MC908QL2			4					MC68HC908QL4											
MC908QF4			4-CH, 8-Bbit					2.2 to 3.6	4			C	32-pin LQFP (FJ)	n/a	Available	Key feature is integration of UHF RF Transmitter.	MC68HC908QF4		

68HC08 FAMILY

68HC08 FAMILY (continued) 68HC08 Product Table (continued)

For complete part number information and temperature definitions, refer to "Product Numbering System for 68HC08" on page SG1006-9.

Product	ROM (KB)	RAM (Bytes)	Flash or OTP (KB)	EEPROM (Bytes)	Timer	I/O	Serial	MUX	A/D	PWM	COP	Operating Voltage (V)	Max Bus Freq (MHz)	Temp	Packaging	OTP or Flash Equiv.	Status	Additional Information	Documentation																														
HC08QB/QT/QY Family—8/16 Pin Low Cost, Small Packages																																																	
MC68HC908QB4	n/a	256	4K Flash	n/a	4-CH, 16-bit IC, OC, PWM	Up to 13	ESCI SPI	n/a	10-CH, 10-bit	See Timer	Y	3.0, 5.0	8.0	M	16-pin TSSOP (DT) 16-pin SOIC (DW) 16-pin PDIP (P)	n/a	Available	Auto Wakeup Module KBI	MC68HC908QB8																														
MC68HC908QB8			8K Flash															Auto Wakeup Module KBI Low Voltage Inhibit																															
MC68HC908QT1	n/a	128	1.5 Flash	n/a	2-CH, 16-bit IC, OC, or PWM	6	n/a	n/a	n/a	See Timer	Y	3.0, 5.0	8.0	C, B, C, B, C, B, C, B, C, B	8-pin SOIC (DW) 8-pin DIP (P) 8-pin DFN (FQ)	n/a	Available	Trimmable (±25%) 3.2 MHz internal OSC (±5% accuracy), external RC, external clock, or external resonator/XTAL, selectable trip point LVI, auto wake up from stop, KBI	MC68HC908QY4																														
MC68HLC908QT1									2.2 to 3.6			MC68HLC908QY4																																					
MC68HC908QT2									3.0, 5.0			MC68HC908QY4																																					
MC68HLC908QT2									2.2 to 3.6			MC68HLC908QY4																																					
MC68HC908QT4									3.0, 5.0			MC68HC908QY4																																					
MC68HLC908QT4									2.2 to 3.6			MC68HLC908QY4																																					
MC68HC908QY1			1.5 Flash			14			n/a			n/a							n/a	n/a	n/a	n/a	See Timer	Y	3.0, 5.0	8.0	C, B, C, B, C, B	16-pin SOIC (DW) 16-pin PDIP (P) 16-pin TSSOP (DT)	n/a	Available	Trimmable (±25%) 3.2 MHz internal OSC (±5% accuracy), external RC, external clock, or external resonator/XTAL, selectable trip point LVI, auto wake up from stop, KBI	MC68HC908QY4																	
MC68HLC908QY1																																2.2 to 3.6	MC68HLC908QY4																
MC68HC908QY2																																3.0, 5.0	MC68HC908QY4																
MC68HLC908QY2																																2.2 to 3.6	MC68HLC908QY4																
MC68HC908QY4																																3.0, 5.0	MC68HC908QY4																
MC68HLC908QY4																																2.2 to 3.6	MC68HLC908QY4																
MC68HC908QY8																																256	8K Flash	n/a	4-CH, 16-bit IC, OC, PWM	Up to 13	n/a	n/a	10-CH, 10-bit	See Timer	Y	3.0, 5.0	8.0	M	16-pin TSSOP (DT) 16-pin SOIC (DW) 16-pin PDIP (P)	n/a	Available	Auto Wakeup Module KBI	MC68HC908QB8
MC68HLC908QY8																																																Auto Wakeup Module KBI	
HC08RF Family—Integrated RF Transmitter																																																	
MC68HC908RF2	n/a	128	2 Flash	n/a	1-CH, 16-bit	12	n/a	n/a	n/a	See Timer	Y	1.8–3.6	4.0	C, M	32-pin LQFP (FA)	Flash	Available	RF transmitter integrated	MC68HC908RF2																														
HC08SR Family—Smart Battery, Temperature Sensor, and I²C																																																	
MC68HC908SR12	n/a	512	12 Flash	n/a	Dual 2-CH, 16-bit IC, OC, or PWM	Up to 31	I ² C SCI	n/a	14-CH, 10-bit	See Timer + 3-CH, 8-bit (125 kHz)	Y	3.0, 5.0	8.0	C, M	48-pin LQFP (FA) 42-pin SDIP (B)	n/a	Available	RC oscillator, 32-kHz PLL, internal oscillator options, 8 keyboard interrupts, TBM, temperature sensor, current detect with amplifier, I ² C supports SMBus version 1.0/1.1	MC68HC908SR12																														
MC68HC08SR12	12		n/a																																														

68HC08 Reference Manuals

CPU08RM, HC08 CPU Reference Manual
TIM08RM, HC08 Timer Reference Manual

68HC08 FAMILY (continued)

Product Numbering System for 68HC08

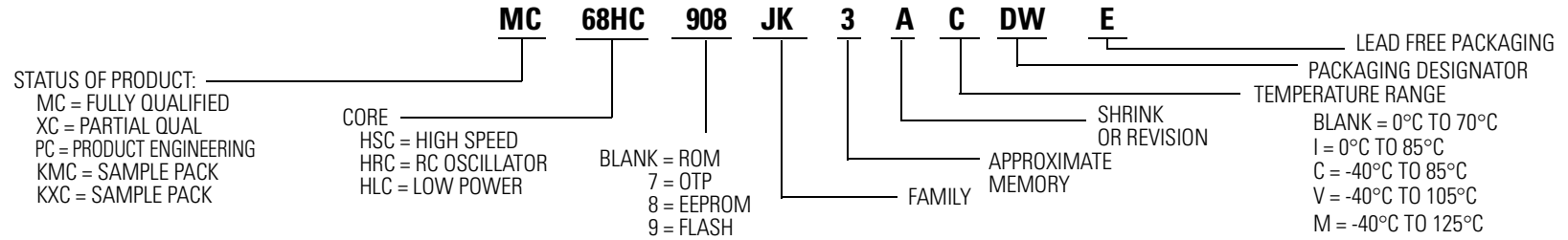

HCS08 FAMILY

HCS08 FAMILY HCS08 Product Table

For complete part number information and temperature definitions, refer to "HCS08 FAMILY (continued)" on page SG1006-11.

Product	ROM (Bytes)	RAM (KB)	Flash or OTP (KB)	EEPROM (Bytes)	Timer	I/O	Serial	A/D	PWM	COP	Operating Voltage (V)	Max Bus Freq (MHz)	Temp	Packaging	OTP or Flash Equiv.	Status	Additional Information	Documentation	
S08AW Family—Appliance Focus																			
MC9S08AW60	n/a	2K	60K Flash	n/a	6-CH +2-CH, 16-bit IC, OC, PWM	Up to 50	1 SPI 2xESCI I ² C	16-CH, 10-bit	See Timer	Y	3.0, 5.0	20	M	44-pin LQFP (FG) 48-pin QFN (FD)	n/a	Available	Low Voltage Inhibit Low Voltage Warming Highly accurate internal oscillator (+/- 5% across temp)	MC9S08AW60	
MC9S08AW48			48K Flash				1 SPI 2xSCI I ² C							44-pin LQFP (FG) 48-pin QFN (FD) 64-pin QFP (FU)					
MC9S08AW32			32K Flash																
S08G Family—High Performance, General Purpose, Low-Voltage with 10-bit A/D																			
MC9S08GB32	n/a	2	32 Flash	n/a	8-CH, 16-bit IC, OC, or PWM	56	I ² C 2 SCI SPI	8-CH, 10-bit	See Timer	Y	1.8 to 3.6	20.0	C	64-pin QFP (FU)	n/a	Available	On-chip debug interface	MC9S08GB60 HCS08RMV1	
MC9S08GB60		4	60 Flash																
MC9S08GT16		2	16 Flash																
MC9S08GT32			32 Flash																
MC9S08GT60			4											60 Flash					
S08R Family—Low Power, High Performance for Battery Powered Applications																			
MC9S08RC8	n/a	1	8 Flash	n/a	2-CH, 16-bit IC, OC, PWM Carrier Modulator Timer	Up to 39	SCI	n/a	See Timer	Y	1.8 to 3.6	8.0	C	32-pin LQFP (FJ) 44-pin LQFP (FG)	n/a	Available	Analog Comparator, Low Voltage Warning	MC9S08RG60	
MC9S08RC16			16 Flash																
MC9S08RC32			2																32 Flash
MC9S08RC60																			60 Flash
MC9S08RD8			1																8 Flash
MC9S08RD16																			16 Flash
MC9S08RD32		2												32 Flash					
MC9S08RD60			60 Flash																
MC9S08RE8			1											8 Flash					
MC9S08RE16		16 Flash																	
MC9S08RE32		2	32 Flash																
MC9S08RE60			60 Flash																
MC9S08RG32			1											32 Flash					
MC9S08RG60		2												60 Flash					

HCS08 FAMILY (continued)
Product Numbering System for HCS08

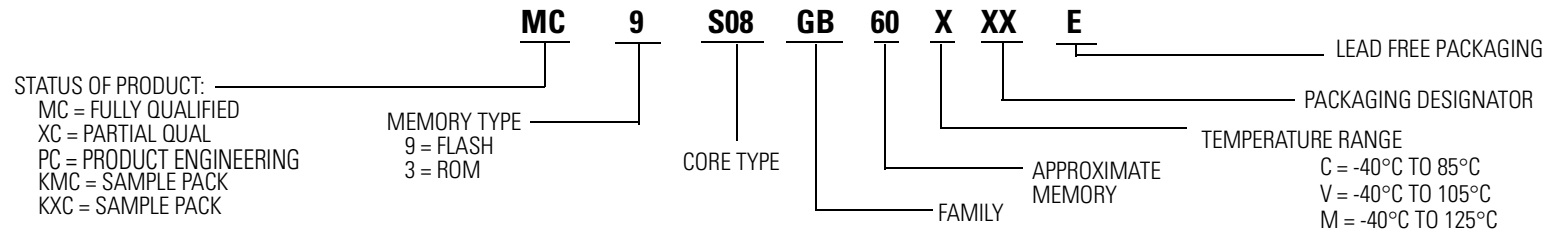

68HC12 FAMILY

68HC12 Product Table

For complete part number information and temperature definitions, refer to "Product Numbering System for 68HC12" on page SG1006-13.

Product	ROM (KB)	RAM (KB)	EEPROM (Bytes)	Flash (KB)	Timer	I/O	Serial	A/D	PWM	Operating Voltage (V)	Max Bus Frequency (MHz)	Temp	Packaging	Status	Additional Information	Documentation
HC12A Family																
MC68HC812A4	n/a	1	4K	n/a	8-CH, 16-bit IC or OC RTI, pulse accumulator	Up to 91	Dual SCI SPI	8-CH, 8-bit	n/a	3.3, 5.0	8.0 5.0	C	112-pin LQFP (PV)	Available	Non-muxed bus, 7 programmable chip selects, KBI (24 pins), PLL, BDM, 5M-byte external memory, 3.0–3.6 V, 5 MHz version (XC68C812A4)	MC68HC812A4
HC12B Family																
MC68HC912B32	n/a	1	768	32	8-CH, 16-bit IC or OC RTI, pulse accumulator	Up to 63	SCI, SPI J1850	8-CH, 10-bit	4-CH, 8-bit or 2-CH, 16-bit	5.0	8.0	C, V, M	80-pin QFP (FU)	Available	J1850, muxed bus, BDM	MC68HC912B
MC68HC12BC32	32			8-CH, 16-bit	SCI, SPI		4-CH, 8-bit		4.5 to 5.5						Part equipped with CAN 2.0A/B	MC68HC912B32TS
XC912BC32	n/a			32	8-CH, 16-bit IC or OC RTI, pulse accumulator		SCI, SPI CAN			4-CH, 8-bit or 2-CH, 16-bit					5.0	MSCAN CAN 2.0B, BDM
MC68HC12BE32	32			n/a	8-CH, 16-bit IC or OC RTI, pulse accumulator		SCI, SPI J1850		4-CH, 8-bit or 2-CH, 16-bit	C						BDM, enhanced timer Evaluation product with on-chip monitor: XC12BE32DCFU8
HC12DG Family																
XC68HC12D60	60	2	1K	n/a	8-CH, 16-bit	Up to 66 I/O and 18 i	Dual SCI SPI	8-CH, 10-bit	4-CH, 8-bit or 2-CH, 16-bit	5.0	8.0	C, V, M	80-pin QFP (FU) 112-pin LQFP (PV)	Available	Part equipped with CAN 2.0A/B	MC68HC912D60
MC912D60A	n/a			60	8-CH, 16-bit IC or OC RTI, pulse accumulator		Dual SCI SPI, CAN								8-CH, 10-bit	
MC912DG128	MC912DG128A is a pin-compatible replacement.															
MC912DG128A	n/a	8	2K	128	8-CH, 16-bit IC or OC RTI, pulse accumulator	Up to 67 I/O and 18 i	Dual SCI SPI, CAN	8-CH or 16-CH, 10-bit	4-CH, 8-bit or 2-CH, 16-bit	5.0	8.0	C, V, M	112-pin LQFP (PV)	Available	Replaces the XC912DG128 with 5 V Flash voltage and a different programming algorithm	MC68HC912DG128
HC12DT Family																
MC68HC912DT128A	n/a	8	2K	128	8-CH, 16-bit	Up to 66 I/O and 18 i	Dual SCI, SPI	Dual 8-CH, 10-bit	4-CH, 8-bit or 2-CH, 16-bit	5.0	8.0	C, V, M	112-pin LQFP (PV)	Available	Part equipped with 3xCAN 2.0A/B	MC68HC912DT128

All 68HC12 MCUs incorporate a COP watchdog timer.

68HC12 Reference Manual

CPU12RM, HC12 CPU Reference Manual

68HC12 FAMILY (continued)
Product Numbering System for 68HC12

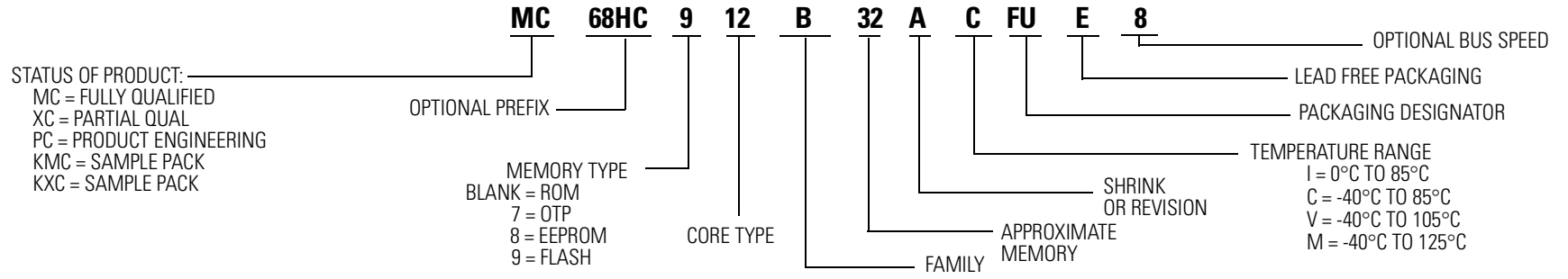

HCS12 FAMILY

HCS12 FAMILY HCS12 Product Table

HCS12 Dx and A Family devices offer pin-for-pin compatibility.

For complete part number information and temperature definitions, refer to "Product Numbering System for HCS12" on page SG1006-17.

Product	ROM (Bytes)	RAM (KB)	Flash or OTP (KB)	EEPROM (KB)	Timer	I/O	Serial	MUX	A/D	PWM	Operating Voltage (V)	Operating Frequency (MHz)	Temp	Packaging	OTP or Flash Equiv.	Status	Additional Information	Documentation
S12A Family—General Purpose with I²C																		
MC9S12A32		2	32 Flash		8-CH, 16-bit ECT	Up to 59	2 SCI 1 SPI		8-CH, 10-bit	7-CH, 8-bit or 3-CH, 16-bit	3.0, 5.0			80-pin QFP (FU)			www.freescale.com	MC9S12DP256
MC9S12A64		4	64 Flash	1			Up to 2 SCI 1 SPI 1 IIC					25.0					The 80 QFP differs from the 112 LQFP in that it offers only up to 59 I/O, has 1 x 8-CH A/D, and has 7-CH PWM	9S12A64DGV1
MC9S12A128	n/a	8	128 Flash	2	8-CH, 16-bit IC, OC, PA	Up to 91	Up to 2 SCI 2 SPI 1 IIC	n/a	Up to 2 x 8-CH, 10-bit	Up to 8-CH, 8-bit or 4-CH, 16-bit	5.0		C	80-pin QFP (FU) 112-pin LQFP (PV)	n/a	Available		9S12A128DGV1
MC9S12A256		12	256 Flash				Up to 2 SCI 3 SPI 1 IIC										www.freescale.com	9S12A256DGV1
MC9S12A512		14	512 Flash	4	8-CH, 16-bit ECT		2 SCI 3 SPI i ² C			8-CH, 8-bit or 4-CH, 16-bit		25.0, 33.0		112-pin LQFP (PV)				MC9S12DP512
S12B Family—Automotive/Industrial with Intermediate Cost CAN																		
MC9S12B128		4	128 Flash		8-CH, 16-bit IC, OC, or PWM	Up to 91	SCI, SPI, i ² C	CAN	8-CH, 16-bit	See Timer	3.0 to 5.0	25	C, V, M	112-pin LQFP (PV) 80-pin QFP (FU)	n/a	Available	www.freescale.com	
MC9S12B64	n/a	2	64 Flash	1														9S12B128DGV1
S12C Family—Low Pin Count, Low Cost CAN																		
MC9S12C128			128 Flash								3.0 to 5.0	25	C, V, M	80-QFP, 52 LQFP, 48 LQFP				9S12C128DGV1
MC9S12C96		4	96 Flash	0	8-CH, 16-bit IC, OC, or PWM	Up to 60	SCI SPI	CAN	8-CH, 10-bit	See Timer								
MC9S12C64	n/a		64 Flash								3.15 to 5.5	16, 25	C, M	48-pin QFP (FA) 52-pin QFP (PB) 80-pin QFP (FU)	n/a	Available	www.freescale.com	
MC9S12C32		2	32 Flash	n/a														9S12C32D6V1

HCS12 FAMILY (continued)
HCS12 Product Table (continued)

HCS12 Dx and A Family devices offer pin-for-pin compatibility.

For complete part number information and temperature definitions, refer to "Product Numbering System for HCS12" on page SG1006-17.

Product	ROM (Bytes)	RAM (KB)	Flash or OTP (KB)	EEPROM (KB)	Timer	I/O	Serial	MUX	A/D	PWM	Operating Voltage (V)	Operating Frequency (MHz)	Temp	Packaging	OTP or Flash Equiv.	Status	Additional Information	Documentation	
S12D Family—Automotive/Industrial with CAN																			
MC9S12D32		2	32 Flash		8-CH, 16-bit ECT	Up to 59	2 SCI 1 SPI	CAN	8-CH, 10-bit	7-CH, 8-bit or 3-CH, 16-bit	5.0			80-pin QFP (FU)			www.freescale.com	MC9S12DP256	
MC9S12D64		4	64 Flash	1			Up to 2 SCI 1 SPI IIC	1 CAN 2.0A/2.0B									The 80 QFP differs from the 112 LQFP in that it offers only up to 59 I/O, has 1 x 8-CH A/D, and has 7-CH PWM	9S12D64DGV1	
MC9S12DB128							Up to 2 SCI 2 SPI	1 CAN Byteflight						80-pin QFP (FU) 112-pin LQFP (PV)			www.freescale.com		
MC9S12DG128		8	128 Flash	2	8-CH, 16-bit IC, OC, PA	Up to 91	Up to 2 SCI 2 SPI IIC	2 CAN	Up to 2 x 8-CH, 10-bit	Up to 8-CH, 8-bit or 4-CH, 16-bit	5.0						The 80 QFP differs from the 112 LQFP in that it offers only up to 59 I/O, has 1 x 8-CH A/D, and has 7-CH PWM	9S12DT128BDGV1	
MC9S12DG256		12	256 Flash	4			2 SCI 3 SPI IIC					25.0		112-pin LQFP (PV)			www.freescale.com	9S12DP256BDGV2	
MC9S12DJ64	n/a	4	64K Flash	1			Up to 2 SCI 1 SPI IIC	1 CAN 2.0A/2.0B and 1 x J1850									The 80 QFP differs from the 112 LQFP in that it offers only up to 59 I/O, has 1 x 8-CH A/D, and has 7-CH PWM	9S12DJ64DGV1	
MC9S12DJ128		8	128 Flash	2	8-CH, 16-bit IC, OC, PA		Up to 2 SCI 2 SPI IIC	2 CAN and 1 x J1850						80-pin QFP (FU) 112-pin LQFP (PV)			The 80 QFP differs from the 112 LQFP in that it offers only up to 59 I/O, has 1 x 8-CH A/D, and has 7-CH PWM	9S12DT128BDGV1	
MC9S12DJ256							Up to 2 SCI 3 SPI IIC												9S12DP256BDGV2
MC9S12DP256		12	256 Flash	4															
MC9S12DP512		4	512 Flash	n/a	8-CH, 16-bit ECT	Up to 91	2 SCI 3 SPI I ² C	5 CAN	Up to 2 x 8-CH, 10-bit	Up to 8-CH, 8-bit or 4-CH, 16-bit	5.0	25.0, 33.0						MC9S12DP512	
MC9S12DT128		8	128 Flash	2			2 SCI 2 SPI IIC							112-pin LQFP (PV)			www.freescale.com	9S12DT128BDGV1	
MC9S12DT256		12	256 Flash	4	8-CH, 16-bit IC, OC, PA		2 SCI 3 SPI IIC	3 CAN				25.0							9S12DP256BDGV2

A change bar appears in the left margin to mark the location of new or revised information.

HCS12 FAMILY

HCS12 FAMILY (continued)

HCS12 Product Table (continued)

HCS12 Dx and A Family devices offer pin-for-pin compatibility.

For complete part number information and temperature definitions, refer to "Product Numbering System for HCS12" on page SG1006-17.

Product	ROM (Bytes)	RAM (KB)	Flash or OTP (KB)	EEPROM (KB)	Timer	I/O	Serial	MUX	A/D	PWM	Operating Voltage (V)	Operating Frequency (MHz)	Temp	Packaging	OTP or Flash Equiv.	Status	Additional Information	Documentation	
S12E Family—General Purpose, 3 Volts with D/A																			
MC9S12E64	n/a	4	64 Flash	n/a	Three 4-CH, 16-bit IC, OC or PWM	Up to 90	3 SCI SPI I ² C	n/a	16-CH, 10-bit	See Timer	3.3 to 5.0	16.0, 25.0	C, M	112-pin LQFP (PV) 80-pin QFP (FU)	n/a	Available	Two D/A Converters	9S12E128DGV1	
MC9S12E128		8	128 Flash																
S12GC Family—Low Cost, Low Pin Count																			
MC9S12GC128	n/a	4	128 Flash	0	8-CH, 16-bit IC, OC, PWM	Up to 60	SCI SPI	n/a	8-CH, 10-bit	See Timer	3.0 to 5.0	25.0	C, V, M	52-pin LQFP (PB) 48-pin LQFP (FA)	n/a	Available	www.freescale.com	9S12C128DGV1	
MC9S12GC96			96 Flash																
MC9S12GC64			64 Flash																
MC9S12GC32		2	32 Flash																
MC9S12GC16			16 Flash																
S12H Family—LCD/H-Bridge Drivers with CAN																			
MC9S12H128B	n/a	12	128 Flash	4	8-CH, 16-bit IC, OC, PA	99 plus 18 inputs	SCI SPI IIC	2 CAN 2.0A/2.0B	16-CH, 10-bit	6-CH, 8-bit or 3-CH, 16-bit	5.0	16.0	V	112-pin LQFP (PV)	n/a	Available	LCD driver module: up to 32 frontpanes and 4 backpanes.	9S12H256BDGV1	
MC9S12H256B			C, V, M										112-pin LQFP (PV) 144-pin LQFP (FV)						

HCS12 FAMILY (continued)

HCS12 Product Table (continued)

HCS12 Dx and A Family devices offer pin-for-pin compatibility.

For complete part number information and temperature definitions, refer to "Product Numbering System for HCS12" on page SG1006-17.

Product	ROM (Bytes)	RAM (KB)	Flash or OTP (KB)	EEPROM (KB)	Timer	I/O	Serial	MUX	A/D	PWM	Operating Voltage (V)	Operating Frequency (MHz)	Temp	Packaging	OTP or Flash Equiv.	Status	Additional Information	Documentation	
S12NE Family—Single Chip with 10/100 Base-T with Integrated MAC and PHY																			
MC9S12NE64	n/a	8	64 Flash	n/a	4-CH, 16-bit IC, OC or PWM	Up to 70	2 SCI SPI I ² C	n/a	8-CH, 10-bit	See Timer	3.0	16.0, 25.0	C (PV) V (TU)	112-pin LQFP (PV) 80-pin TQFP-EP (TU)	n/a	Available	Integrated Media Access Controller (EMAC), 10/100 Ethernet PHY (EPHY)	9S12NE64BDUG	
S12T Family—CALRAM with Fast BDM																			
MC9S12T64	n/a	2 + 2 CALRAM	64 Flash	n/a	8-CH, 16-bit IC, OC, PA	25	2 SCI 1 SPI	n/a	8-CH, 10-bit	8-CH, 8-bit or 4-CH, 16-bit	5.0	16.0	C, V, M	80-pin QFP (PK)	n/a	Available	FBDM (Fast Background Debug Mode)	9S12T64BDGV1	
S12UF Family—USB 2.0																			
MC9S12UF32	n/a	3.5	32 Flash	n/a	8-CH, 16-bit IC, OC, or PWM	Up to 75	SCI USB 2.0	n/a	n/a	See Timer	5.0	30.0	0°C to 70°C	100-pin LQFP (PU) 64-pin LQFP	n/a	Available	Built-in host controller modules for ATA-5 interface, CompactFlash, Secure Digital/Multimedia Card, SmartMedia, and Memory Stick	9S12UF32DGV1	

Note: M temperature range limited to single-chip mode

Product Numbering System for HCS12

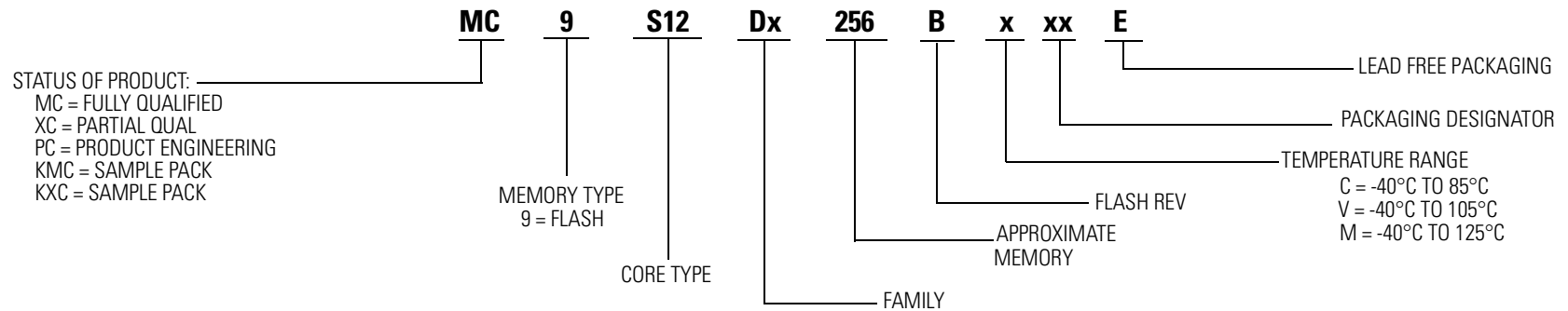

HCS12X FAMILY

HCS12X FAMILY

HCS12X Product Table

HCS12 Dx and A Family devices offer pin-for-pin compatibility.

For complete part number information and temperature definitions, refer to "Product Numbering System for HCS12X" on page SG1006-19.

Product	ROM (KB)	RAM (KB)	Flash (KB) Serial	EEPROM (KB)	Timer	I/O	XGATE	Serial	MUX	A/D	PWM	Packaging	Oper Voltage (V)	Oper Freq (MHz)	Temp	Flash or OTP	Status	Additional Information	Documentation
MC9S12XDP512	n/a	32	512	4	8-CH, 16-bit ECT	91	Yes	4 SCI 3 SPI 1 I ² C	5 CAN	2 x 8-CH, 10-bit	8-CH, 8-bit or 4-CH, 16-bit	112-pin LQFP	3.3 to 5.5	40.0	C, V, M	n/a	Production	Target MC Qual date, May	9S12XDP512DVG1
MC9S12XDP512						119		6 SCI 3 SPI 2 I ² C		2 x 12-CH, 10-bit		144-pin LQFP							
MC9S12XDT512	n/a	20	512	4	8-CH, 16-bit ECT	59	Yes	2 SCI 2 SPI 1 I ² C	3 CAN	1 x 8-CH, 10-bit	7-CH, 8-bit or 3-CH, 16-bit	80-pin QFP	3.3 to 5.5	40.0	C, V, M	n/a	Production	Target MC Qual date, May	9S12XDP512DVG1
MC9S12XDT512						91		4 SCI 3 SPI 1 I ² C		2 x 8-CH, 10-bit	8-CH, 8-bit or 4-CH, 16-bit	112-pin LQFP							
MC9S12XDT512						119		6 SCI 3 SPI 1 I ² C		2 x 12-CH, 10-bit	8-CH, 8-bit or 4-CH, 16-bit	144-pin LQFP							
MC9S12XDT256	n/a	16	256	4	8-CH, 16-bit ECT	59	Yes	2 SCI 2 SPI 1 I ² C	3 CAN	1 x 8-CH, 10-bit	7-CH, 8-bit or 3-CH, 16-bit	80-pin QFP	3.3 to 5.5	40.0	C, V, M	n/a	Production	Target MC Qual date, May	9S12XDP512DVG1
MC9S12XDT256						91		4 SCI 3 SPI 1 I ² C		2 x 8-CH, 10-bit	8-CH, 8-bit or 4-CH, 16-bit	112-pin LQFP							
MC9S12XDT256						119		4 SCI 3 SPI 1 I ² C		2 x 12-CH, 10-bit	8-CH, 8-bit or 4-CH, 16-bit	144-pin LQFP							
MC9S12XD256	n/a	14	256	4	8-CH, 16-bit ECT	59	Yes	2 SCI 2 SPI 1 I ² C	1 CAN	1 x 8-CH, 10-bit	7-CH, 8-bit or 3-CH, 16-bit	80-pin QFP	3.3 to 5.5	40.0	C, V, M	n/a	Production	Target MC Qual date, May	9S12XDP512DVG1
MC9S12XD256						91		4 SCI 2 SPI 1 I ² C		2 x 8-CH, 10-bit	8-CH, 8-bit or 4-CH, 16-bit	112-pin LQFP							
MC9S12XD256						119		4 SCI 2 SPI 1 I ² C		2 x 12-CH, 10-bit	8-CH, 8-bit or 4-CH, 16-bit	144-pin LQFP							

A change bar appears in the left margin to mark the location of new or revised information.

HCS12X FAMILY (continued)

HCS12X Product Table (continued)

HCS12 Dx and A Family devices offer pin-for-pin compatibility.

For complete part number information and temperature definitions, refer to "Product Numbering System for HCS12X" on page SG1006-19.

Product	ROM (KB)	RAM (KB)	Flash (KB) Serial	EEPROM (KB)	Timer	I/O	XGATE	Serial	MUX	A/D	PWM	Packaging	Oper Voltage (V)	Oper Freq (MHz)	Temp	Flash or OTP	Status	Additional Information	Documentation
MC9S12XA512	n/a	32	512	4	8-CH, 16-bit IC, OC, PWM	59	Yes	2 SCI 2 SPI 1 I ² C	n/a	1 x 8-CH, 10-bit	7-CH, 8-bit or 3-CH, 16-bit	80-pin QFP	3.3 to 5.5	40.0	C, V	n/a	Production	Target MC Qual date, May	9S12XDP512DVG1
91						4 SCI 3 SPI 1 I ² C		2 x 8-CH, 10-bit		8-CH, 8-bit or 4-CH, 16-bit	112-pin LQFP								
119						6 SCI 3 SPI 2 I ² C		2 x 12-CH, 10-bit		8-CH, 8-bit or 4-CH, 16-bit	144-pin LQFP								
MC9S12XA256	n/a	16	267	4	8-CH, 16-bit IC, OC, PWM	59	Yes	2 SCI 2 SPI 1 I ² C	n/a	1 x 8-CH, 10-bit	7-CH, 8-bit or 3-CH, 16-bit	80-pin QFP	3.3 to 5.5	40.0	C, V	n/a	Production	Target MC Qual date, May	9S12XDP512DVG1
91						4 SCI 3 SPI 1 I ² C		2 x 8-CH, 10-bit		8-CH, 8-bit or 4-CH, 16-bit	112-pin LQFP								
119						4 SCI 3 SPI 1 I ² C		2 x 12-CH, 10-bit		8-CH, 8-bit or 4-CH, 16-bit	144-pin LQFP								
MC9S12XA256																		2005	

Product Numbering System for HCS12X

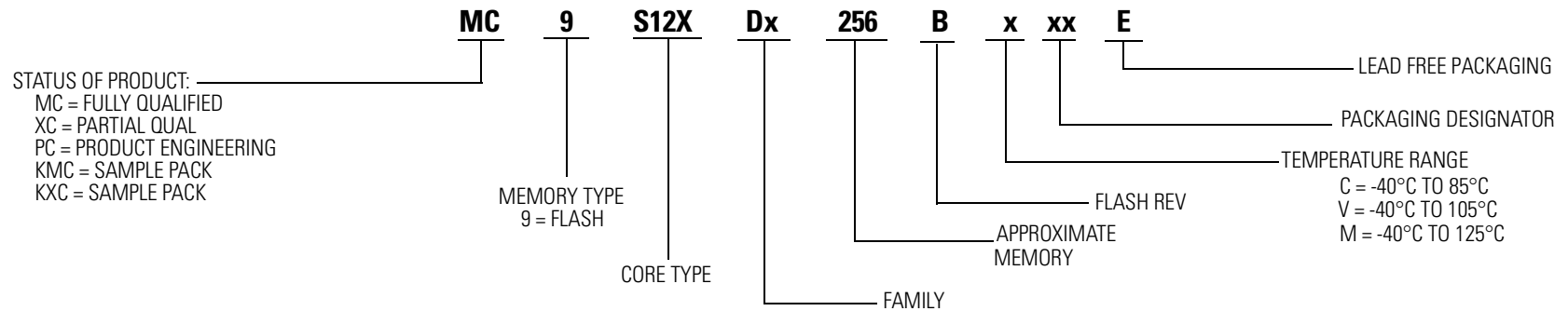

A change bar appears in the left margin to mark the location of new or revised information.

MCF5xxx FAMILY

MCF5xxx Product Table

For complete part number information and temperature definitions, refer to "MCF5xxx FAMILY (continued)" on page SG1006-22.

Product	Core	Dhrys 2.1 MIPS @ max MHz	Processor Cache (Bytes)	Processor Flash (Kbytes)	Processor SRAM (Bytes)	Serial Interface, UART	Timers/ CS/ GPIO	DMA	DRAM Controller	10/100 Eth/ USB1.1	Operating Voltage (V)	Operating Frequency (MHz)	Temp	Packaging	Rev	Additional Information
MCF5206	V2	17	512 I	n/a	512K	2 UARTs	2/8/8	n/a	FPM, EDO	n/a	5	16, 25, 33	C	160-pin QFP	A	www.freescale.com.
MCF5206E		50	4K I		8K			2-CH			3.3	40, 54			Enhanced pin-compatible version of 5206 with MAC, HW divide, BDM, I ² C, 5V tolerant I/O.	
MCF5207		159	8K Conf. I/D	16K	3	8/8/up to 30	16-CH	DDR/SDR	One 10/100	1.5, 2.5, 3.3	166	144-pin LQFP 144-ball MAPBGA	32x32 EMAC, QSPI, I ² C, Production Q4 2005			
MCF5208						8/8/up to 50						160-pin QFP 196-ball MAPBGA				
MCF5211		76	n/a	256	32K	16/0/up to 33	4-CH	None	n/a	3.3	66, 80	64-pin LQFP 81-ball MAPBGA	32x32 EMAC, QSPI, I ² C, 10-CH, 12-bit ADC, September 2005			
MCP5212						16/0/up to 44						100-pin LQFP 81-ball MAPBGA				
MCF5213		66	2K I	n/a	64K	3 UARTs, 1 PC, 1 CAN	8 + 4 DAM/7/ up to 150	4-CH	SDRAM	n/a	3.3, 5	80, 100, 150	256-ball MAPBGA	256 KB Flash. 512 KB Flash.		
MCF5214													142	8K Config.	3 UARTs	24/8/up to 102
MCF5216		24/8/up to 142	2x CAN	100, 150	32-CH eTPU.											
MCF5232						125	8K I	96K	2 UARTs, I ² C, QSPI	2/4/up to 47	4-CH	SDRAM	n/a	1.8, 3.3	140	256-ball MAPBGA
MCF5233		107	8K Conf. I/D	64K	3 UARTs											2/3/up to 34
MCF5234						144	8K Conf. I/D	64K	3 UARTs	8/8/up to 39	4-CH	SDRAM	n/a	1.8, 3.3	140	
MCF5235		8/8/up to 61	160-pin QFP	32x32 EMAC, QSPI, I ² C.												
MCF5249					144	8K Conf. I/D	64K	3 UARTs	8/8/up to 61	4-CH	SDRAM	n/a	1.8, 3.3	140	160-pin QFP	32x32 EMAC, QSPI, I ² C.
MCF5249L		144-pin LQFP														
MCF5270		144	8K Conf. I/D	64K	3 UARTs	8/8/up to 61	4-CH	SDRAM	n/a	1.8, 3.3	140	140	160-pin QFP	32x32 EMAC, QSPI, I ² C.		
MCF5270	196-ball MAPBGA															

A change bar appears in the left margin to mark the location of new or revised information.

MCF5xxx FAMILY (continued)
MCF5xxx Product Table (continued)

For complete part number information and temperature definitions, refer to "MCF5xxx FAMILY (continued)" on page SG1006-22.

Product	Core	Dhrvs 2.1 MIPS @ max MHz	Processor Cache (Bytes)	Processor Flash (Kbytes)	Processor SRAM (Bytes)	Serial Interface, UART	Timers/ CS/ GPIO	DMA	DRAM Controller	10/100 Eth/ USB1.1	Operating Voltage (V)	Operating Frequency (MHz)	Temp	Packaging	Rev	Additional Information	
MCF5271	V2	144	8K Conf. I/D	n/a	64K	3 UARTs	8/8/up to 39	4-CH	SDRAM	One 10/100	1.5, 3.3	100	C	160-pin QFP	n/a	Hardware Encryption, 32x32 EMAC, QSPI, I ² C.	
MCF5271							8/8/up to 61							B			
MCF5272		63	1K I		4K	10/100 FEC, 2 UARTs, USB, QSPI	4/8/up to 32	2-CH		MAC/ MAC+PHY	3.3	66	C	196-ball MAPBGA		MAC, HW divide, BDM, 4 TDM GCI/IDL ports, software HDCL module, QSPI, 3 PWMs, 5 V tolerant I/O.	
MCF5274L		159	16K Conf. I/D		64K	3 UARTs	8/8/up to 61	4-CH	DDR	One 10/100, USB 2.0 Full-Sp Device	1.5, 2.5, 3.3	166	B	C	256-ball MAPBGA	n/a	Hardware Encryption, 32x32 EMAC, QSPI, I ² C.
MCF5274							8/8/up to 69			Two 10/100, USB 2.0 Full-Sp Device					196-ball MAPBGA		
MCF5275L							8/8/up to 61			One 10/100, USB 2.0 Full-Sp Device							
MCF5275							8/8/up to 69			Two 10/100, USB 2.0 Full-Sp Device							
MCF5280		63	2K I		64K	3 UARTs, I ² C, QSPI, FlexCAN	4 Timers, +4 DMA Timers, 7 Chip Sel., Up to 150 I/Os	4-CH	SDRAM	MAC (FEC)/n/a	3.3, 5.0	66, 80	C	256-ball MAPBGA	n/a	Enhanced CAN 2.0B controller. Flashless version of MCF5282.	
MCF5281		54														Enhanced CAN 2.0B controller, 256 KB Flash. This product incorporates SuperFlash® technology licensed from SST.	
MCF5282																Enhanced CAN 2.0B controller, 512 KB Flash. This product incorporates SuperFlash® technology licensed from SST.	
MCF5307	V3	75	8K I		2 UARTs, I ² C		SDRAM, FPM, EDO		3.3	66, 90			B	MAC, HW divide, BDM, PLL, I ² C, 5 V tolerant I/O.			
MCF5407	V4	316	16K I, 8K D		4K	UART, USART, I ² C	2/8/16	SDRAM, FPM, EDO	n/a	1.8, 3.3	162, 220			A	Pin-compatible 5307 performance upgrade with MAC, HW divide, BDM, PLL, I ² C, 3.3 V tolerant I/O.		

A change bar appears in the left margin to mark the location of new or revised information.

MCF5xxx FAMILY (continued)
MCF5xxx Product Table (continued)

For complete part number information and temperature definitions, refer to "MCF5xxx FAMILY (continued)" on page SG1006-22.

Product	Core	Dhrys 2.1 MIPS @ max MHz	Processor Cache (Bytes)	Processor Flash (Kbytes)	Processor SRAM (Bytes)	Serial Interface, UART	Timers/ CS/ GPIO	DMA	DRAM Controller	10/100 Eth/ USB1.1	Operating Voltage (V)	Operating Frequency (MHz)	Temp	Packaging	Rev	Additional Information
MCF5470	V4e	308	32K I, 32K D	n/a	32K	4	6/6/up to 99	16-CH	DDR/SDR	Two 10/100, PCI	1.5, 2.5, 3.3	200	B	388-ball TEPBGA	n/a	www.freescale.com
MCF5471										Crypto Enabled.						
MCF5472										www.freescale.com						
MCF5473										Crypto Enabled.						
MCF5474		www.freescale.com														
MCF5475		Crypto Enabled.														
MCF5480		255								166		www.freescale.com				
MCF5481												Crypto Enabled.				
MCF5482										www.freescale.com						
MCF5483										Crypto Enabled.						
MCF5484		308								200		www.freescale.com				
MCF5485												Crypto Enabled. Contact Freescale for product status.				

Note: Extended temperature products with minimum order requirements. All temperature/speed combinations may not be valid. Consult the factory to verify.

MCF5xxx FAMILY (continued)
Product Numbering System for MCF5xxx Family

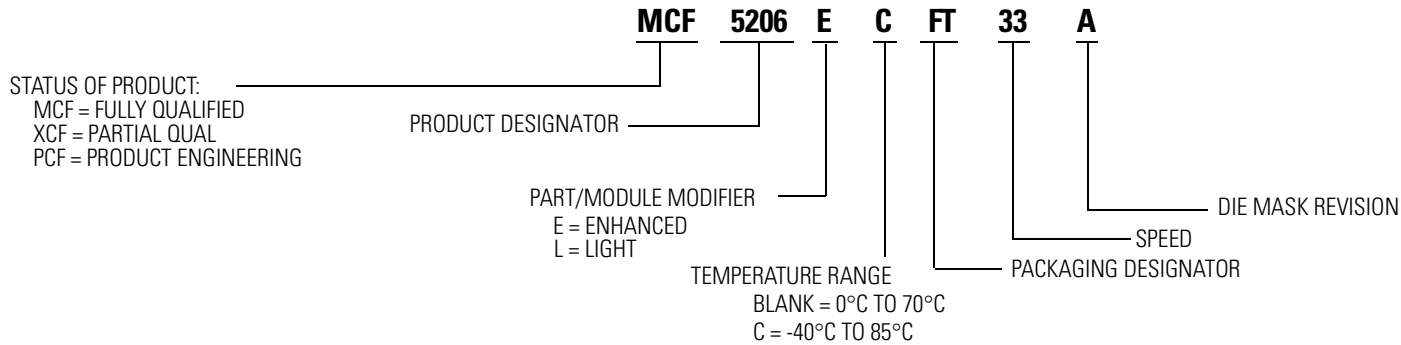

56800 FAMILY

56F800 Series General Purpose 16-bit Fixed Point *Note*

Product	Performance	Program ROM/RAM/Flash	Data ROM/RAM/Flash	Peripherals	Packaging	Additional Information
DSP56F801FA80 DSP56F801FA80E	80 MHz 40 MIPS	n/a/1K/8K (words)	n/a/1K/2K (words)	SCI, SPI, ADC, PWM, Quad Timer	48-pin LQFP 48-pin LQFP*	MCU-friendly instruction set, OnCE for debug, on-chip relaxation oscillator, 2K Boot Flash, up to 11 GPIO.
DSP56F801FA60 DSP56F801FA60E	60 MHz 30 MIPS					MCU-friendly instruction set, OnCE for debug, on-chip relaxation oscillator, 2K Boot Flash, up to 11 GPIO.
DSP56F802TA80 DSP56F802TA80E	80 MHz 40 MIPS			SCI, ADC, PWM, Quad Timer	32-pin LQFP 32-pin LQFP*	MCU-friendly instruction set, OnCE for debug, on-chip relaxation oscillator, 2K Boot Flash, up to 4 GPIO.
DSP56F802TA60 DSP56F802TA60E	60 MHz 30 MIPS					MCU-friendly instruction set, OnCE for debug, on-chip relaxation oscillator, 2K Boot Flash, up to 4 GPIO.
DSP56F803BU80 DSP56F803BU80E	80 MHz 40 MIPS	n/a/512K/32K (words)	n/a/2K/4K (words)	CAN, SCI, SPI, ADC, PWM, Quadrature Decoder, Quad Timer	100-pin LQFP 100-pin LQFP*	MCU-friendly instruction set, OnCE for debug, 2K Boot Flash, external memory expansion available, up to 16 GPIO.
DSP56F805FV80 DSP56F805FV80E					144-pin LQFP 144-pin LQFP*	MCU-friendly instruction set, OnCE for debug, 2K Boot Flash, external memory expansion available, up to 32 GPIO.
DSP56F807PY80 (LQFP) DSP56F807PY80E (LQFP) DSP56F807VF80 (MAPBGA) DSP56F807VF80E (MAPBGA)		160-pin LQFP 160-pin LQFP* 160-ball MAPBGA 160-ball MAPBGA*	MCU-friendly instruction set, OnCE for debug, 2K Boot Flash, external memory expansion available, up to 32 GPIO. MOQ of 40 for LQFP.			
DSP56F826BU80 DSP56F826BU80E		n/a/512K/32K (words)	n/a/4K/2K (words)	SCI, SPI, SSI, TOD, Quad Timer	100-pin LQFP 100-pin LQFP*	MCU-friendly instruction set, OnCE for debug, 2K Boot Flash, external memory expansion available, up to 48 GPIO.
DSP56F827FG80 DSP56F827FG80E		n/a/1K/64K (words)	n/a/4K/4K (words)	SCI, SPI, SSI, TOD, ADC, Quad Timer	128-pin LQFP 128-pin LQFP*	MCU-friendly instruction set, OnCE for debug, external memory expansion available, up to 52 GPIO.

Note: Contact your local Freescale Semiconductor Sales Office or authorized Freescale Semiconductor distributor for product availability.

*This package is RoHS compliant.

A change bar appears in the left margin to mark the location of new or revised information.

56800E FAMILY

56850 Series General Purpose 16-bit Fixed Point *Note*

Product	Performance	Boot ROM/ Program RAM Data RAM	Off-Chip Memory Expansion (EMI)	Peripherals	Packaging	Additional Information
DSP56852VF120 DSP56852VFE	120 MHz 120 MIPS	1K/6K/4K (words)	Up to 2M program and 6M of data	SCI, SPI, ISSI, EMI, COP, Quad Timer	81-ball MAPBGA 81-ball MAPBGA*	MCU-friendly instruction set, Enhanced OnCE for debug, up to four programmable chip select signals, and up to 11 GPIO.
DSP56853FG120 DSP56853FGE		1K/12K/4K (words)	Up to 2M program and 8M of data	2 SCI, SPI, ESSI, HI, EMI, COP, DMA, TOD, Quad Timer	128-pin LQFP 128-pin LQFP*	MCU-friendly instruction set, Enhanced OnCE for debug, six channels of DMA, up to four programmable chip select signals, and up to 41 GPIO.
DSP56854FG120 DSP56854FGE		1K/16K/16K (words)				MCU-friendly instruction set, Enhanced OnCE for debug, six channels of DMA, up to four programmable chip select signals, and up to 41 GPIO.
DSP56855BU120 DSP56855BUE		1K/24K/24K (words)	n/a	2 SCI, ESSI, EMI, COP, DMA, TOD, Quad Timer	100-pin LQFP 100-pin LQFP*	MCU-friendly instruction set, Enhanced OnCE for debug, six channels of DMA, on-chip relaxation oscillator, up to four programmable chip select signals, and up to 18 GPIO.
DSP56857BU120 DSP56857BUE		1K/40K/24K (words)				MCU-friendly instruction set, Enhanced OnCE for debug, six channels of DMA, and up to 47 GPIO.
DSP56858FV120 (LQFP) DSP56858FVE (LQFP) DSP56858VF120 (MAPBGA)				Up to 2M program and 8M of data	2 SCI, SPI, 2 ESSI, HI, EMI, COP, DMA, TOD, Quad Timer	144-pin LQFP 144-pin LQFP* 144-ball MAPBGA

Note: Contact your local Freescale Semiconductor Sales Office or authorized Freescale Semiconductor distributor for product availability.

*This package is RoHS compliant.

A change bar appears in the left margin to mark the location of new or revised information.

56800E FAMILY (continued)

56F8300 Series General Purpose 16-bit Fixed Point *Note*

Product	Performance	Flash/RAM (KB)	Off-Chip Memory Expansion (EMI)	Peripherals	Packaging	Additional Information
F832x Family						
MC56F8322MFA60 MC56F8322MFAE	60 MHz 60 MIPS	48/12	n/a	2 SPI, 2 SCI, 2 ADC, PWM, COP, PLL, Decoder, 2 Quad Timers, FlexCAN	48-pin LQFP 48-pin LQFP*	Extended (-40°C to 125°C) MCU-friendly instruction set, Enhanced OnCE for debug, on-chip relaxation oscillator, temperature sensor, and up to 21 GPIOs. 0
MC56F8322VFA60 MC56F8322VFAE					48-pin LQFP 48-pin LQFP*	Industrial (-40°C to 105°C), MCU-friendly instruction set, Enhanced OnCE for debug, on-chip relaxation oscillator, temperature sensor and up to 21 GPIOs.
MC56F8323MFB60 MC56F8323MFB6E					64-pin LQFP 64-pin LQFP*	Extended (-40°C to 125°C), MCU-friendly instruction set, Enhanced OnCE for debug, on-chip relaxation oscillator, temperature sensor, and up to 27 GPIOs.
MC56F8323VFB60 MC56F8323VFB6E					64-pin LQFP 64-pin LQFP*	Industrial (-40°C to 105°C), MCU-friendly instruction set, Enhanced OnCE for debug, on-chip relaxation oscillator, temperature sensor, and up to 27 GPIOs.
F833x Family						
MC56F8335VFG60	60 MHz 60 MIPS	80/12	n/a	2 SPI, 2 SCI, 4ADC, PWM, COP, PLL, 2 Decoders, 4 Quad Timers, FlexCAN	128-pin LQFP*	Industrial (-40°C to 105°C), MCU-friendly instruction set, Enhanced OnCE for debug, temperature sensor, and up to 49 GPIOs.
MC56F8335MFG6E						Industrial (-40°C to 105°C), MCU-friendly instruction set, Enhanced OnCE for debug, temperature sensor, and up to 49 GPIOs.
F834x Family						
MC56F8345MFG60 MC56F8345MFG6E	60 MHz 60 MIPS	144/12	n/a	2 SPI, 2 SCI, 4 ADC, 2 PWM, COP, PLL, 2 Decoders, 4 Quad Timers, FlexCAN	128-pin LQFP 128-pin LQFP*	Extended (-40°C to 125°C), MCU-friendly instruction set, Enhanced OnCE for debug, temperature sensor, and up to 49 GPIOs..
MC56F8345VFG60 MC56F8345VFG6E					128-pin LQFP 128-pin LQFP*	Industrial (-40°C to 105°C), MCU-friendly instruction set, Enhanced OnCE for debug, temperature sensor, and up to 49 GPIOs.
MC56F8346MVF60 MC56F8346MVF6E			Yes		144-pin LQFP 144-pin LQFP*	Extended (-40°C to 125°C), MCU-friendly instruction set, Enhanced OnCE for debug, temperature sensor, and up to 62 GPIOs.
MC56F8346VVF60 MC56F8346VVF6E					144-pin LQFP 144-pin LQFP*	Industrial (-40°C to 105°C), MCU-friendly instruction set, Enhanced OnCE for debug, temperature sensor, and up to 62 GPIOs.
MC56F8347MPY60 MC56F8347MPY6E					160-pin LQFP 160-pin LQFP* 160-pin MAPBGA*	Extended (-40°C to 125°C), MCU-friendly instruction set, Enhanced OnCE for debug, temperature sensor, and up to 76 GPIOs.
MC56F8347VPY60 (LQFP) MC56F8347VPY6E (LQFP) MC56F8347VVFE (MAPBGA)					Industrial (-40°C to 105°C), MCU-friendly instruction set, Enhanced OnCE for debug, temperature sensor, and up to 76 GPIOs.	

Note: Contact your local Freescale Semiconductor Sales Office or authorized Freescale Semiconductor distributor for product availability.

*This package is RoHS compliant.

A change bar appears in the left margin to mark the location of new or revised information.

56800E FAMILY (continued)

56F8300 Series General Purpose 16-bit Fixed Point^{Note} (continued)

Product	Performance	Flash/RAM (KB)	Off-Chip Memory Expansion (EMI)	Peripherals	Packaging	Additional Information
F835x Family						
MC56F8355MFG60 MC56F8355MFGE	60 MHz 60 MIPS	280/20	Yes	2 SPI, 2 SCI, 4 ADC, 2 PWM, COP, PLL, 2 Decoders, 4 Quad Timers, FlexCAN	128-pin LQFP 128-pin LQFP*	Extended (-40°C to 125°C), MCU-friendly instruction set, Enhanced OnCE for debug, temperature sensor, and up to 49 GPIOs.
MC56F8355VFG60 MC56F8355VFGE			n/a		128-pin LQFP 128-pin LQFP*	Industrial (-40°C to 105°C), MCU-friendly instruction set, Enhanced OnCE for debug, temperature sensor, and up to 49 GPIOs.
MC56F8356MVF60 MC56F8356MFVE			Yes		144-pin LQFP 144-pin LQFP*	Extended (-40°C to 125°C), MCU-friendly instruction set, Enhanced OnCE for debug, temperature sensor, and up to 62 GPIOs.
MC56F8356VVF60 MC56F8356VFVE			Yes		144-pin LQFP 144-pin LQFP*	Industrial (-40°C to 105°C), MCU-friendly instruction set, Enhanced OnCE for debug, temperature sensor, and up to 62 GPIOs.
MC56F8357MPY60 MC56F8357MPYE			Yes		160-pin LQFP 160-pin LQFP*	Extended (-40°C to 125°C), MCU-friendly instruction set, Enhanced OnCE for debug, temperature sensor, and up to 76 GPIOs.
MC56F8357VPY60 (LQFP) MC56F8357VPYE (LQFP) MC56F8357VVFE (MAPBGA)			Yes		160-pin LQFP 160-pin LQFP* 160-pin MAPBGA*	Industrial (-40°C to 105°C), MCU-friendly instruction set, Enhanced OnCE for debug, temperature sensor, and up to 76 GPIOs.
F836x Family						
MC56F8365VFG60 MC56F8365VFGE	60 MHz 60 MIPS	576/36	n/a	2 SPI, 2 SCI, 4 ADC, 2 PWM, COP, PLL, 2 Decoders, 4 Quad Timers, 2 FlexCAN	128-pin LQFP 128-pin LQFP*	Industrial (-40°C to 105°C), MCU-friendly instruction set, Enhanced OnCE for debug, temperature sensor, and up to 49 GPIOs.
MC56F8365MFG60 MC56F8365MFGE			Yes		128-pin LQFP 128-pin LQFP*	Extended (-40°C to 125°C), MCU-friendly instruction set, Enhanced OnCE for debug, temperature sensor, and up to 49 GPIOs.
MC56F8366VFG60 MC56F8366VFGE			Yes		144-pin LQFP 144-pin LQFP*	Industrial (-40°C to 105°C), MCU-friendly instruction set, Enhanced OnCE for debug, temperature sensor, and up to 62 GPIOs.
MC56F8366MVF60 MC56F8366MFVE			Yes		144-pin LQFP 144-pin LQFP*	Extended (-40°C to 125°C), MCU-friendly instruction set, Enhanced OnCE for debug, temperature sensor, and up to 62 GPIOs.
MC56F8367VPY60 (LQFP) MC56F8367VPYE (LQFP) MC56F8367VVFE (MAPBGA)			Yes		160-pin LQFP 160-pin LQFP* 160-ball MAPBGA*	Industrial (-40°C to 105°C), MCU-friendly instruction set, Enhanced OnCE for debug, temperature sensor, and up to 76 GPIOs.
MC56F8367MPY60 MC56F8367MPYE (LQFP)			Yes		160-pin LQFP 160-pin LQFP*	Extended (-40°C to 125°C), MCU-friendly instruction set, Enhanced OnCE for debug, temperature sensor, and up to 76 GPIOs.

Note: Contact your local Freescale Semiconductor Sales Office or authorized Freescale Semiconductor distributor for product availability.

*This package is RoHS compliant.

A change bar appears in the left margin to mark the location of new or revised information.

56800E FAMILY (continued)

56F8000 Series General Purpose 16-bit Fixed Point *Note*

Product	Performance	Flash/RAM (KB)	Peripherals	Packaging	Additional Information
MC56F8013VFAE	32 MHz 32 MIPS	16/4	6 CH PWM, Quad Timer, SPI, SCI with LIN slave, PLL, dual 3-CH, 12-bit ADCs, COP, POR, I ² C, On-Chip oscillator	32-pin LQFP	Industrial (-40°C to 105°C), MCU-friendly instruction set, Enhanced OnCE for debug, temperature sensor, and up to 26 GPIOs.
MC56F8014VFAE			5 CH PWM, Quad Timer, SPI, SCI with LIN slave, PLL, dual 4-CH, 12-bit ADCs, COP, POR, I ² C, On-Chip oscillator		Industrial (-40°C to 105°C), MCU-friendly instruction set, Enhanced OnCE for debug, temperature sensor, and up to 26 GPIOs.
Applications		Development Tools		Benefits	
<ul style="list-style-type: none"> Smart sensors Industrial motor control Dimming lamp ballast Switched-mode power supply Soft-switching PFC Appliance motor control DC-DC power supplies 		Refer to Development Tools beginning on page SG1004-23.		Because of its low cost, configuration flexibility, and compact program code, the 56F8013 is well suited for many applications. The 56800E core is based on a Harvard architecture consisting of three execution units operating in parallel, allowing as many as six operations per instruction cycle. The microprocessor-style programming model and optimized instruction set allow straightforward generation of efficient, compact code for both DSP and MCU applications.	

Note: Contact your local Freescale Semiconductor Sales Office or authorized Freescale Semiconductor distributor for product availability.

A change bar appears in the left margin to mark the location of new or revised information.

56800E FAMILY (continued)

56F8100 Series General Purpose 16-Bit Fixed Point ^{Note}

Product	Performance	Flash/RAM (KB)	Off-Chip Memory Expansion (EMI)	Peripherals	Packaging	Additional Information
MC56F8122VFA MC56F8122VFAE	40 MHz 40 MIPS	40/8	n/a	2 SPI, 2 SCI, 2 ADC, COP, PLL, Quad Timer	48-pin LQFP 48-pin LQFP*	Industrial (-40°C to 105°C), MCU-friendly instruction set, Enhanced OnCE for debug, on-chip relaxation oscillator, and up to 21 GPIOs.
MC56F8123VFB MC56F8123VFBE					64-pin LQFP 64-pin LQFP*	Industrial (-40°C to 105°C), MCU-friendly instruction set, Enhanced OnCE for debug, on-chip relaxation oscillator, and up to 27 GPIOs.
MC56F8135VFG		72/8		128-pin LQFP*	128-pin LQFP 128-pin LQFP*	Industrial (-40°C to 105°C), MCU-friendly instruction set, Enhanced OnCE for debug, and up to 49 GPIOs.
MC56F8145VFG MC56F8145VFG		136/8				
MC56F8146VFB MC56F8146VFE			272/16	Yes	160-pin LQFP 160-pin LQFP*	Industrial (-40°C to 105°C), MCU-friendly instruction set, Enhanced OnCE for debug and up to 76 GPIOs.
MC56F8147VPY MC56F8147VPYE		272/16				
MC56F8155VFG MC56F8155VFG			544/32	Yes	144-pin LQFP 144-pin LQFP*	Industrial (-40°C to 105°C), MCU-friendly instruction set, Enhanced OnCE for debug and up to 62 GPIOs.
MC56F8156VFB MC56F8156VFE		544/32				
MC56F8157VPY MC56F8157VPYE			544/32	Yes	128-pin LQFP 128-pin LQFP*	Industrial (-40°C to 105°C), MCU-friendly instruction set, Enhanced OnCE for debug and up to 49 GPIOs.
MC56F8165VFG MC56F8165VFG		544/32				
MC56F8166VFB MC56F8166VFE			544/32	Yes	160-pin LQFP 160-pin LQFP*	Industrial (-40°C to 105°C), MCU-friendly instruction set, Enhanced OnCE for debug and up to 76 GPIOs.
MC56F8167VPY MC56F8167VPYE		544/32				

Note: Contact your local Freescale Semiconductor Sales Office or authorized Freescale Semiconductor distributor for product availability.

*This package is RoHS compliant.

68HC16 FAMILY

68HC16 Product Table

Product	ROM (KB)	RAM (KB)	Flash (KB)	Product Integration	Timer	Serial	Analog	Operating Voltage (V)	Operating Frequency (MHz)	Temp	Packaging	Flash	Status	Additional Information	Documentation
MC68HC16Z1	0	1	0	SIM	GPT	SCI, queued SPI	8-CH 10-bit	5.0 2.7 to 3.6	16, 20, 25	C, V, M	132-pin PQFP 144-pin LQFP	n/a	Available	2.7 V to 3.6 V, 16 MHz version MC68CK16Z1 with 32kHz crystal in 144-pin LQFP package only; MC68CM16Z1 with 4MHz crystal in 144-pin LQFP package only	MC68HC16ZUM
MC68HC16Z3	8	4						5.0	16, 25	C, V				www.freescale.com	

Note: All package, speed, and temperature combinations may not be valid. Consult factory to verify.

68HC16 Reference Manuals

CPU16RM, HC16 CPU Reference Manual

SIMRM, System Integration Module Reference Manual

TPURM, Timer Processor Unit Reference Manual

GPTRM, General-Purpose Timer Reference Manual

QSMRM, Queued Serial Module Reference Manual

ADCRM, Analog-to-Digital Converter Reference Manual

CTMRM, Configurable Timer Module Reference Manual

MCCIRM, Multi-Channel Communication Interface Reference Manual

SCIMRM, Single-Chip Integration Module Reference Manual

Product Numbering System for 68HC16

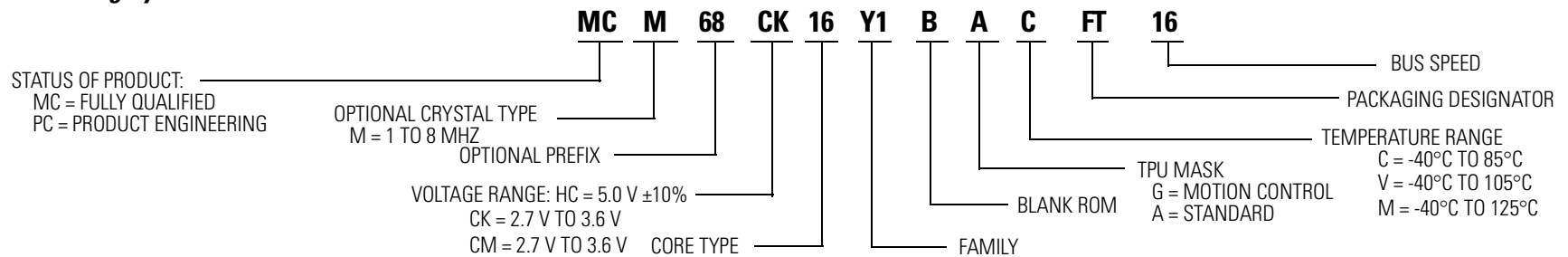

683xx FAMILY
683xx Product Table

Product	ROM (KB)	RAM (KB)	Flash (KB)	Device Integration	Timer	Serial	A/D	Operating Voltage (V)	Operating Frequency (MHz)	Temp	Packaging	Status	Additional Information	Documentation
MC68331	0	0	0	SIM	GPT	SCI, queued SPI	n/a	5.0	16, 20, 25	C, V, M	132-pin PQFP 144-pin LQFP	Available	2.7 V to 3.6 V, 16 MHz version (MC68CK331). MC68CK331 is on end of life	MC68331UM MC68CK331EC16
MC68332		2			3.0 V to 3.6 V, 16 MHz version (MC68LK332)								MC68332UM MC68LK332EC16	
MC68336		4 + 3.5			Queued 16-CH 10-bit	TPU CTM4	CAN, SCI, queued SPI		20, 25		160-pin QFP		www.freescale.com	MC68336/376PP MC68336/376UM
MC68376	8													

Note: All package, speed, and temperature combinations may not be valid. Consult factory to verify.

683xx Reference Manuals

- CPU32RM, CPU32 Reference Manual
- SIMRM, System Integration Module Reference Manual
- TPURM, Timer Processor Unit Reference Manual
- GPTRM, General-Purpose Timer Reference Manual
- QSMRM, Queued Serial Module Reference Manual
- ADCRM, Analog-to-Digital Converter Reference Manual
- CTMRM, Configurable Timer Module Reference Manual

Product Numbering System for 683xx Family

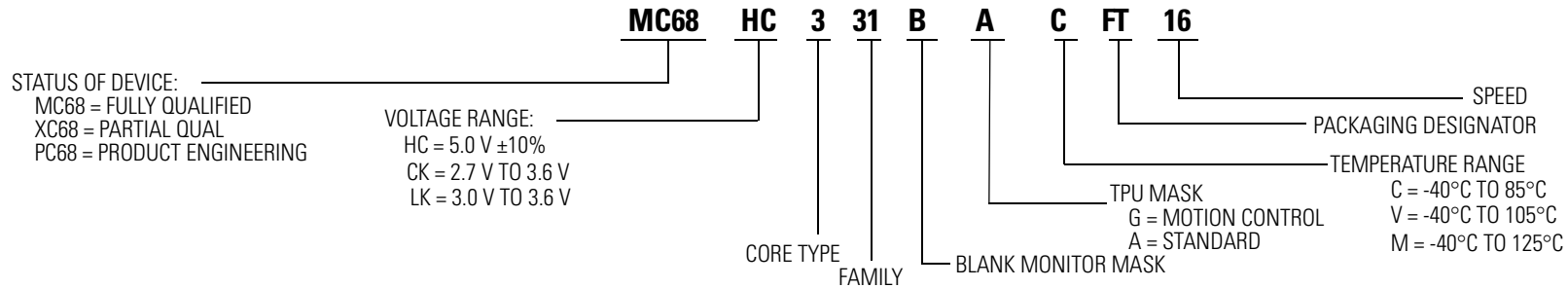

LEGACY PRODUCTS

68HC05 FAMILY

68HC05 Product Table

For complete part number information and temperature definitions, refer to "Product Numbering System for 68HC05" on page SG1006-34.

Product	ROM (KB)	RAM (Bytes)	EPROM/OTP (KB)	EEPROM (Bytes)	Timer	I/O	Serial	A/D	PWM	COP	Operating Voltage (V)	Max Bus Frequency (MHz)	Temp	Packaging	OTP	Status	Additional Information	Documentation
HC05B Family																		
MC68HC05B6	6	176	n/a	256	16-bit, 2 IC, 2 OC	32	SCI	8-CH, 8-bit	2-CH, 8-bit	Y	3.3, 5.0	4.0	C, V, M	56-pin SDIP (B) 52-pin PLCC (FN) 64-pin QFP (FU)	705B16 705B32	Available	SCI has synchronous master SPI-like capability	MC68HC05B6
MC68HC05B8	7												C, V					
MC68HC05B16	15	352	15										C, V, M	52-pin PLCC (FN) 64-pin QFP (FU)	n/a			
MC68HC705B16N	n/a																	
MC68HC05B32	32	528	n/a	2.1	PLCC/QFP: C, V, M SOIC: B	56-pin SDIP (B) 52-pin PLCC (FN) 64-pin QFP (FU)	705B32	SCI has synchronous master SPI-like capability										
MC68HC05BD5	7.75	256	n/a		MFT	24	I ² C	n/a	16-CH, 8-bit	5.0	B only	40-pin DIP (P) 42-pin SDIP (B)	705BD3	Horizontal and vertical sync signal processor	MC68HC05BD3D			
HC05C Family																		
MC68HC05C8A	8	176	n/a	n/a	16-bit, 1 IC, 1 OC	31	SCI SPI	n/a	n/a	Y	3.3, 5.0	4.0	C, V	40-pin DIP (P) 42-pin SDIP (B) 44-pin PLCC (FN) 44-pin QFP (FB)	705C8A	Available	KBI (8 pins), 1 high-current pin (20 mA), automotive qual complete	MC68HC05C8A
MC68HC705C8A	n/a	304	8										C, V, M	40-pin DIP (P) 42-pin SDIP (B) 44-pin PLCC (FN) 44-pin QFP (FB) 64-pin QFP (FU)	n/a		KBI (8 pins), 1 high-current pin (20 mA), high-speed option (4-MHz bus) available as MC68HSC705C8A	MC68HC705C8A
MC68HC05C9A	16	352	n/a										C, V, M	40-pin DIP (P) 42-pin SDIP (B) 44-pin PLCC (FN) 44-pin QFP (FB)	705C9A		KBI (8 pins), 1 high-current pin (20 mA)	MC68HC05C9A
MC68HC705C9A	n/a		16										2.1	C	40-pin DIP (P) 42-pin SDIP (B) 44-pin PLCC (FN) 44-pin QFP (FB)		n/a	KBI (8 pins), 1 high-current pin (20 mA) Automotive qual complete

LEGACY PRODUCTS 68HC05 FAMILY

LEGACY PRODUCTS (continued) 68HC05 FAMILY (continued) 68HC05 Product Table (continued)

For complete part number information and temperature definitions, refer to "Product Numbering System for 68HC05" on page SG1006-34.

Product	ROM (KB)	RAM (Bytes)	EPROM/OTP (KB)	EEPROM (Bytes)	Timer	I/O	Serial	A/D	PWM	COP	Operating Voltage (V)	Max Bus Frequency (MHz)	Temp	Packaging	OTP	Status	Additional Information	Documentation
HC05F Family																		
MC68HC705F32	n/a	920	32	256	16-bit, 4 IC, 4 OC, MFT, RTI	Up to 80	SCI SPI	8-CH, 8-bit	3-CH, 8-bit	Y	3.0, 5.0	2.1	B only	100-pin LQFP (PU) 80-pin QFP (FU)	n/a	Available	DTMF, LCD (4 x 40), KBI (8 pins) Note: FU package is XC qualified only	MC68HC05F32
HC05J Family																		
MC68HC05J1A	1.2	64	n/a	n/a	MFT, RTI	14	n/a	n/a	n/a	Y	2.0, 3.3, 5.0	4.0	C, V	20-pin DIP (P) 20-pin SOIC (DW)	705J1A	Available	KBI (4 pins), mask selectable pull-downs, 4 high-current pins (8 mA)	MC68HC05J1A
MC68HC705J1A	n/a		3.3, 5.0								n/a				KBI (4 pins), programmable pull-downs, 4 high-current pins (8 mA), RC option available as MC68HRC705J1A, high-speed option available as MC68HSC705J1A		MC68HC705J1A MC68HC705J1AAD	
MC68HC05J5A	2.5	128	n/a	n/a	16-bit, 1 IC, MFT, RTI	14	n/a	n/a	n/a	Y	2.2, 5.0	2.1	B only	20-pin DIP (P) 20-pin SOIC (DW) 16-pin DIP (JP) 16-pin SOIC (JDW)	705J5A	Available	2 high-current pins (25 mA), LVR, RC option available	HC05J5AGRS
MC68HC705J5A	n/a		5.0								n/a							
MC68HC05JJ6	6	224	n/a	n/a	16-bit, 1 IC, 1 OC, MFT, RT	22	SIOP	4-CH, 12-bit	n/a	Y	3.3, 5.0	2.1	C	20-pin DIP (P) 20-pin SOIC (DW)	705JJ7	Available	2 voltage comparators used as single slope A/D, KBI (8 pins), 6 high-current pins (10 mA), mask selectable pull-downs, LVR	HC05JJ6GRS HC705JJ7GRS
XC68HC705JJ7	n/a		6 + 64-bit PEP											n/a				
MC68HC05JP6	6		n/a															
XC68HC705JP7	n/a	6 + 64-bit PEP	n/a											28-pin DIP (P) 28-pin SOIC (DW)	n/a		2 voltage comparators used as single slope A/D, KBI (8 pins), 6 high-current pins (10 mA), programmable pull-downs, LVR.	HC705JJ7GRS
HC05K Family																		
MC68HC05K3	0.9	64	n/a	16 PEEP	MFT, RTI	10	n/a	n/a	n/a	Y	2.1	3.3, 5.0	C	16-pin SOIC (DW) 20-pin SSOP (SD)	805K3	Available	Personality EEPROM, RTI, KBI.	MC68HC05K3
MC68HC705KJ1	n/a		1.2	n/a										4.0	16-pin DIP (P) 16-pin SOIC (DW)		n/a	KBI (4 pins), programmable pull-downs (10 pins), 4 high-current pins (10 mA), RC option available as MC68HRC705KJ1. High-speed standard. 32 kHz low-power version available as MC68HLC705KJ1.

LEGACY PRODUCTS (continued)

68HC05 FAMILY (continued)

68HC05 Product Table (continued)

For complete part number information and temperature definitions, refer to "Product Numbering System for 68HC05" on page SG1006-34.

Product	ROM (KB)	RAM (Bytes)	EPROM/OTP (KB)	EEPROM (Bytes)	Timer	I/O	Serial	A/D	PWM	COP	Operating Voltage (V)	Max Bus Frequency (MHz)	Temp	Packaging	OTP	Status	Additional Information	Documentation							
HC05L Family																									
MC68HC05L16	16	512	n/a	n/a	16-bit, 1 IC, 1 OC, 8-bit, 1 IC, 1 OC, RTI	39	SIOP	n/a	n/a	n/a	2.2, 3.3, 5.0	2.1	C	80-pin QFP (FU)	705L16	Available	LCD with 4x39 segments, KBI (8 pins), dual oscillators, 8 high-current pins, programmable pull-ups, open drain.	HC05L16GRS							
MC68HC705L16	n/a		16								n/a														
MC68HC05L25	6	176	n/a								16-bit Event, Timebase			20	SPI				2-CH, 8-bit	Y	3.3, 5.0	52-pin LQFP (PB) 32-pin LQFP (FA)	705L26	24 x 4 or 25 x 3 LCD.	HC05L25GRS
MC68HC05LJ5	1.2	64	n/a								MFT, RTI			14	n/a				n/a	5.0	B only	16-pin DIP (P)	705J5A	RC option available.	HC05LJ5GRS
HC05P Family																									
MC68HC05P4A	4	176	n/a	n/a	16-bit, 1 IC, 1 OC	21	SIOP	n/a	n/a	Y	3.3, 5.0	2.1	C, V	28-pin DIP (P) 28-pin SOIC (DW)	705P6A	Available	KBI, 2 high-current pins. Not recommended for electrically noisy environments, EMC sensitive. Halt mode not available.	MC68HC05P4A							
MC68HC05P6	4.5		4-CH, 8-bit					C, V, M					www.freescale.com.						MC68HC05P6 MC68HC05P6AD						
MC68HC705P6A	n/a		4.5					4-CH, 8-bit					C	28-pin DIP (P) 28-pin SOIC (DW) 28-pin SSOP (SD)	n/a				KBI (8 pins), 2 high-current pins (15 mA). Umbrella OTP for P1A, P4A, P6, and P9A Automotive qual complete.	HC705P6AGRS					

LEGACY PRODUCTS 68HC05 FAMILY

LEGACY PRODUCTS (continued)

68HC05 FAMILY (continued)

68HC05 Product Table (continued)

For complete part number information and temperature definitions, refer to "Product Numbering System for 68HC05" on page SG1006-34.

Product	ROM (KB)	RAM (Bytes)	EPROM/OTP (KB)	EEPROM (Bytes)	Timer	I/O	Serial	A/D	PWM	COP	Operating Voltage (V)	Max Bus Frequency (MHz)	Temp	Packaging	OTP	Status	Additional Information	Documentation
HC05SR Family																		
MC68HC05SR3	3.75	192	n/a	n/a	8-bit	32	n/a	4-CH, 8-bit	n/a	n/a	3.3, 5.0	2.1	C	40-pin DIP (P) 44-pin QFP (FB) 42-pin SDIP (B)	705SR3	Available	LED drive, LVR, KBI.	MC68HC05SR3D
MC68HC705SR3	n/a		n/a												n/a			
HC05SU Family																		
MC68HC05SU3A	3.75	192	n/a	n/a	8-bit	32	n/a	n/a	n/a	n/a	5.0	2.1	B only	40-pin DIP (P)	705SR3	Available	KBI, LED drive	MC68HC05SU3A

68HC05 Reference Manuals

M68HC05AG, Applications Guide

M68HC05TB, Understanding Small Microcontrollers Text Book

Product Numbering System for 68HC05

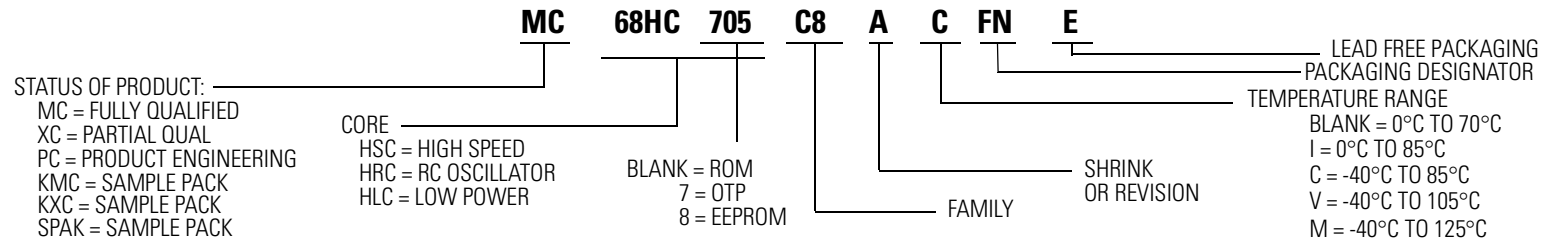

LEGACY PRODUCTS (continued)

68HC11 FAMILY

68HC11 Product Table

For complete part number information and temperature definitions, refer to "Product Numbering System for 68HC11" on page SG1006-36.

Product	ROM (KB)	RAM (Bytes)	EPROM/OTP (KB)	EEPROM (Bytes)	Timer	I/O S.C.	I/O EXP	Serial	A/D	PWM	Operating Voltage (V)	Max Bus Frequency (MHz)	Temp	Packaging	OTP	Status	Additional Information	Documentation
HC11D/E Family																		
MC68HC11D0	n/a	192	n/a	n/a	16-bit, 3/4 IC, 4/5 OC, RTI, pulse accumulator	n/a	16	SCI SPI	n/a	n/a	3.0, 5.0	3.0	C, V, M	44-pin QFP (FB) 44-pin PLCC (FN)	711D3	Available	64K external address bus, 3 V, 2 MHz version (MC68L11D0)	MC68HC11D3
MC68HC11D3	4		4			5.0											64K external address bus, 3 V, 2 MHz version (MC68L11D3)	
MC68HC711D3	n/a		4			n/a					5.0	64K external address bus, 3 MHz available in C temperature range only		MC68HC711D3				
MC68HC11E0	n/a	512	n/a	512	16-bit, 3/4 IC, 4/5 OC, RTI, pulse accumulator	n/a	22	SCI SPI	8-CH, 8-bit	n/a	3.0, 5.0	3.0	C, V, M	52-pin PLCC (FN) 64-pin QFP (FU) 52-pin LQFP (PB)	711E9	Available	3 V, 2 MHz version (MC68L11E0)	MC68HC11E
MC68HC11E1						12											12	
MC68HC11E9	12					12					3 V, 2 MHz version (MC68L11E9)							
MC68HC711E9	n/a	768	n/a	512	16-bit, 3/4 IC, 4/5 OC, RTI, pulse accumulator	38	22	SCI SPI	8-CH, 8-bit	n/a	5.0	4.0	C, V, M	52-pin PLCC (FN) 64-pin QFP (FU)	711E20	Available	EEPROM block protect. Secure version (MC68S711E9)	MC68HC11F1
MC68HC11E20	20																n/a	
MC68HC711E20	n/a										20	Enhanced baud rate for 3 MHz operation						
HC11F Family																		
MC68HC11F1	n/a	1K	n/a	512	16-bit, 3/4 IC, 4/5 OC, RTI, pulse accumulator	n/a	30	SCI SPI	8-CH, 8-bit	n/a	3.0, 5.0	5.0	C, V, M	68-pin PLCC (FN) 80-pin LQFP (PU)	n/a	Available	64K ext. addr. bus, 4 prog. chip sel, non-mux address/data bus, 3 V, 3 MHz version (MC68L11F1)	MC68HC11F1

LEGACY PRODUCTS (continued)
68HC11 FAMILY (continued)
68HC11 Product Table (continued)

For complete part number information and temperature definitions, refer to "Product Numbering System for 68HC11" on page SG1006-36.

Product	ROM (KB)	RAM (Bytes)	EPROM/OTP (KB)	EEPROM (Bytes)	Timer	I/O S.C.	I/O EXP	Serial	A/D	PWM	Operating Voltage (V)	Max Bus Frequency (MHz)	Temp	Packaging	OTP	Status	Additional Information	Documentation	
HC11K Family																			
MC68HC11K0	n/a	768	n/a	n/a	16-bit, 3/4 IC, 4/5 OC, RTI, pulse accumulator	n/a	37	SCI+ SPI	8-CH 8-bit	4-CH, 8-bit or 2-CH, 16-bit	2.0, 3.0, 4.0, 5.0	3.0, 5.0	C, V, M	84-pin PLCC (FN) 80-pin QFP (FU)	n/a	Available	Non-mux bus, extended memory map, 4 chip selects, 3 V, 3 MHz version (MC68L11K0)	MC68HC11K4	
MC68HC11K1				5.0							Non-mux bus, extended memory map, 4 chip selects, 3 V, 3 MHz version (MC68L11K1)								
MC68HC11K4	24			62		711K4 (limited)	Non-mux bus, extended memory map, 4 chip selects, 3 V, 3 MHz version (MC68L11K4). Automotive qual complete												
MC68HC11KS2	32	1K	32	640	16-bit, 3/4 IC, 4/5 OC, RTI, pulse accumulator	51	35	4-CH, 8-bit or 2-CH, 16-bit	8-CH 8-bit	n/a	5.0	4.0	68-pin PLCC (FN) 80-pin LQFP (PU)	n/a	711KS2	www.freescale.com	MC68HC11K		
MC68HC711KS2	n/a																		
HC11P Family																			
MC68HC11P1	n/a	1K	n/a	640	16-bit, 3/4 IC, 4/5 OC, RTI, pulse accumulator	62	37	Triple SCI SPI	8-CH, 8-bit	4-CH, 8-bit or 2-CH, 16-bit	5.0	4.0	C	84-pin PLCC (FN)	711P2 (limited)	Available	64K external address bus, MI-bus interface, PLL clock circuitry	MC68HC11P2	
MC68HC11P2	32																		

All 68HC11 MCUs incorporate a COP watchdog timer.

68HC11 Reference Manual

M68HC11RM, 68HC11 Reference Manual

Product Numbering System for 68HC11

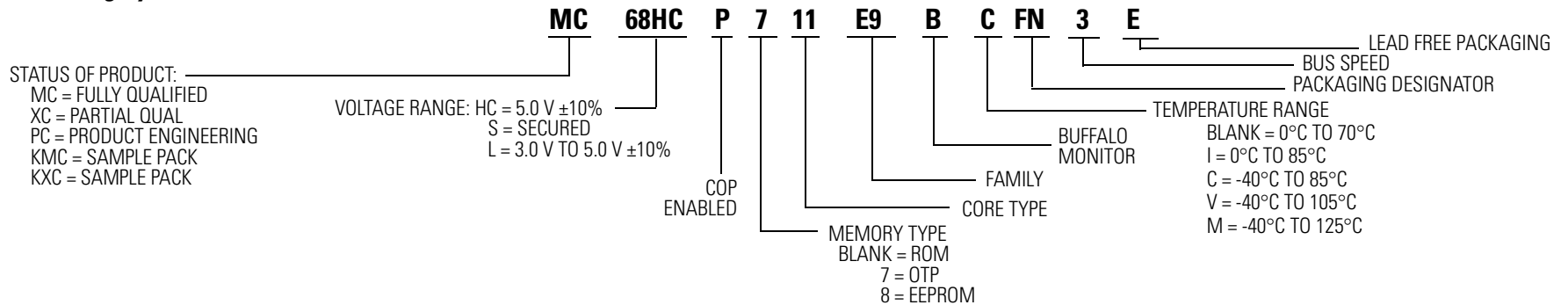

MMC2100 FAMILY
MMC2100 Product Table

Product	ROM (KB)	RAM (KB)	Flash (KB)	Timer	PWM	Serial	A/D	Operating Voltage (V)	Operating Frequency (MHz)	Temp	Packaging	Status	Additional Information	Documentation
MMC2001	256	32	0	Time-of-day, periodic interrupt timer, COP	6-CH 10-bit	Dual UART Interval SPI	n/a	1.8 to 3.6	33	C	144-pin LQFP	Samples Available	ROM includes debugger, peripheral product drivers, and a monitor; external bus interface with 22 address/16 data and 4 chip selects, OnCE debug module, KBI (16 pins). Sample part number: KMMC2001HCPV33B	MMC2001RM MCORERM
MMC2107	0	8	128	Dual 4-channel 16-bit capture/compare, PWM capability, watchdog	See Timer	Dual SCI, SPI	Queued 8-CH 10-bit	2.7 to 3.6			100-pin LQFP 144-pin LQFP	Available	PLL clock, 32 source interrupt controller, periodic interrupt timer, external bus interface with 23 address, 16/32 data and 4 chip select lines, OnCE debug module.	MMC2107 MCORERM
MMC2113		32	256					100-pin LQFP 144-pin LQFP 196-ball MAPBGA			PLL clock, 32 source interrupt controller, periodic interrupt timer, external bus interface with 23 address, 16/32 data and 4 chip select lines, OnCE debug module, Offers Flash Security This product incorporates SuperFlash® technology licensed From SST.		MMC2114	
MMC2114														

Product Numbering System for MMC2100

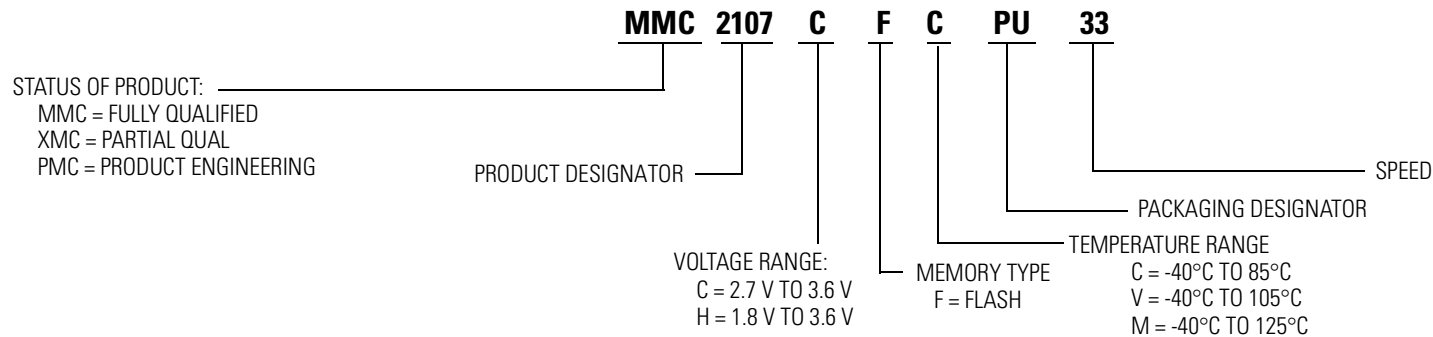

MPC500 FAMILY

MPC500 FAMILY

MPC500 Product Table

For complete part number information and temperature definitions, refer to "Product Numbering System for MPC500" on page SG1006-38.

Product	ROM (KB)	RAM (KB)	Flash (KB)	Product Integration	Timer	Serial	MUX	A/D	PWM	Operating Voltage	Operating Frequency (MHz)	Temp	Packaging	Status	Additional Information	Documentation
MPC533	0	32	512	USIU	22-channel timer system; MIOS14	QSMCM (2 SCI + QSPI) + 1 TouCAN	1 x TouCAN	1 QADC (10-bit A/D with 64 result registers) 32 channels on chip	12 x PWM	2.6, 5.0	40	C	388-ball PBGA	Available	www.freescale.com	MPC533UM MPC533PB
MPC534								Offers code compression								
MPC535		www.freescale.com	MPC535UM MPC535PB													
MPC536		Offers code compression														
MPC555		26 + 6 for TPU	448		50-channel timer system; 2 TPU3 + MIOS1	QSMCM (2 SCI + QSPI) + 2 TouCAN	2 x TouCAN	2 QADC (10-bit A/D with 64 result registers) 32 channels on chip	8 x PWM	3.3 Vdc for core, 5.0 Vdc for Flash	A, C, M	272-ball PBGA	www.freescale.com		MPC555UM TPURM RCPURM	
MPC561		32 + 8 for TPU + 2 for DEGRAM	0		54-channel timer system; 2 TPU3 + MIOS14	QSMCM (2 SCI + 1 QSPI) + 3 TouCAN	3 x TouCAN	2 QADC (10-bit A/D with 64 result register) 32 channels on chip	12 x PWM	2.6 Vdc for core, 5.0 Vdc for A/D and I/O	40, 56, 66	C, M	388-ball PBGA		Offers code compression	MPC561RM TPURM RCPURM
MPC562			www.freescale.com												MPC563RM TPURM RCPURM	
MPC563		512	1M		70-channel timer system; 3 TPU3 + MIOS14	QSMCM x 2 (4 SCI + 2 QSPI) + 3 TouCAN	3 x TouCAN 1 x J1850	2 QADC (10-bit A/D with 64 result registers) 40 channels on chip	12 x PWM	2.6 Vdc for core, 5.0 Vdc for A/D and I/O	40 or 56	A, C, M	388-ball PBGA			Offers code compression
MPC564															www.freescale.com	
MPC565		36 + 10 for TPU + 4 for DEGRAM	1M		70-channel timer system; 3 TPU3 + MIOS14	QSMCM x 2 (4 SCI + 2 QSPI) + 3 TouCAN	3 x TouCAN 1 x J1850	2 QADC (10-bit A/D with 64 result registers) 40 channels on chip	12 x PWM	2.6 Vdc for core, 5.0 Vdc for A/D and I/O	40 or 56	A, C, M	388-ball PBGA		Offers code compression	MPC566UM TPURM RCPURM
MPC566	www.freescale.com															

Note: Extended temperature products with minimum order requirements. All package/speed/temperature combinations may not be valid - consult factory to verify.

Product Numbering System for MPC500

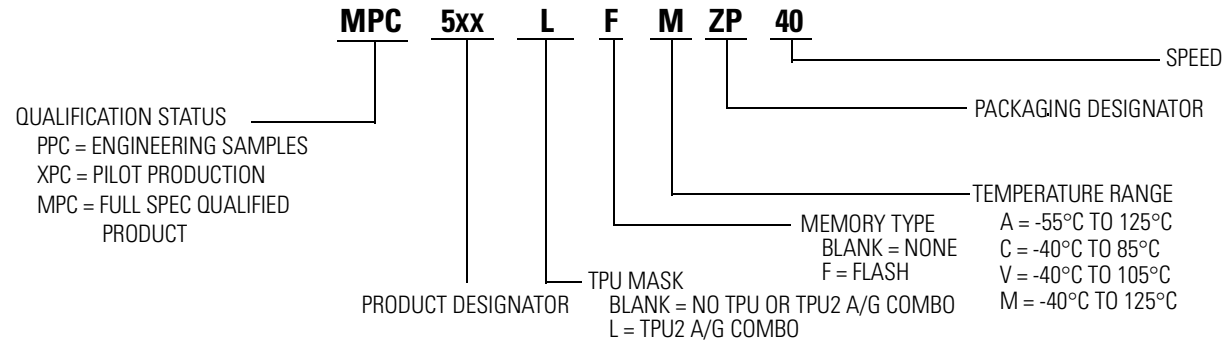

CONTROLLER AREA NETWORK MICROCONTROLLERS

68HC08 Family CAN MCUs

Product	ROM (KB)	RAM (KB)	Flash or OTP (KB)	EEPROM (Bytes)	Timer	I/O	Serial	A/D	PWM	COP	Operating Voltage (V)	Max Bus Frequency (MHz)	Temp (Note)	Packaging	OTP or Flash Equiv.	Status	Additional Information	Documentation
XC68HC08AZ32	32	1	n/a	512	4-CH + 2-CH, 16-bit IC, OC, or PWM	40/50	SCI SPI CAN	8-CH or 15-CH, 8-bit	See Timer	Y	5.0	8.4	C, V, M	64-pin QFP (FU) 52-pin PLCC (FN)	908AZ60A	Available	CAN 2.0A and 2.0B	MC68HC08AZ32/D
MC908AZ60A	n/a	2	60 Flash	1K	6-CH + 2-CH, 16-bit IC, OC, or PWM	50		15-CH, 8-bit						64-pin QFP (FU)	n/a		MC908AZ60A is pin-for-pin compatible replacement for MC68HC908AZ60. CAN 2.0A and 2.0B	MC68HC908AZ60A/D
MC68HC08AZ60	60		n/a		48	32-pin QFP (FJ) 48-pin LQFP (FA)		908AZ60						CAN 2.0A and 2.0B	MC68HC08AZ60/D			
MC68HC908GZ8	n/a	1	8 Flash	n/a	Dual 2-CH, 16-bit IC, OC, or PWM	Up to 37	ESCI SPI	8-CH, 10-bit	See Timer	Y	3.0, 5.0	8.0	C, V, M	32-pin QFP (FJ) 48-pin LQFP (FA)	n/a	Available	MSCAN 2.0	MC68HC908GZ16/D
MC68HC908GZ16			16 Flash															MC68HC908GZ16/D
MC68HC908GZ32	n/a	1.5	32 Flash	n/a	2-CH + 6-CH, 16-bit IC, OC, or PWM	Up to 50	1 SPI 1 ESCI	24-CH, 10-bit	See Timer	Y	3.0, 5.0	8.0	C, V, M	32-pin LQFP (FJ) 48-pin LQFP (FA) 64-pin QFP (FU)	n/a	Available	1 to 8 MHz high frequency oscillator	MC68HC908GZ32/D
MC68HC908GZ48			48 Flash															MC68HC908GZ48/D
MC68HC908GZ60			60 Flash															MC68HC908GZ60/D

Note: C = -40°C to 85°C, M = -40°C to 125°C, and V = 85°C to 105°C.

CONTROLLER AREA NETWORK MICROCONTROLLERS (continued)

68HC12 Family CAN MCUs (continued)

Product	ROM (Bytes)	RAM (KB)	Flash (KB)	EEPROM (Bytes)	Timer (Note 1)	I/O	Serial	A/D	PWM	Operating Voltage (V)	Max Bus Frequency (MHz)	Temp (Note 2)	Packaging	Status	Additional Information	Documentation
XC912BC32	n/a	1	32	768	8-CH, 16-bit IC or OC RTI, pulse accumulator	Up to 63	SCI, SPI CAN	8-CH, 10-bit	4-CH, 8-bit or 2-CH, 16-bit	4.5 to 5.5	8.0	C, V, M	80-pin QFP (FU)	Available	MSCAN CAN 2.0B, BDM Sample pack part number: KXC912BC32CFU8	MC68HC912B
MC912D60A		2	60	1K		Up to 66 I/O and 18 i	Dual SCI SPI, CAN			8-CH or 16-CH, 10-bit			5.0			80-pin QFP (FU) 112-pin LQFP (PV)
MC912DG128A		8	128	2K					112-pin LQFP (PV)				Replaces the XC912DG128 with 5 V Flash voltage and a different programming algorithm			MC68HC912DG128

Note 1: All 68HC12 MCUs incorporate a COP watchdog timer.

Note 2: C = -40°C to 85°C, M = -40°C to 125°C, and V = -40°C to 105°C.

HCS12 Family CAN MCUs

HCS12 Dx and A Family devices offer pin-for-pin compatibility.

For complete part number information and temperature definitions, refer to "Product Numbering System for HCS12" on page SG1006-17.

Product	ROM (Bytes)	RAM (KB)	Flash or OTP (KB)	EEPROM (KB)	Timer	I/O	Serial	MUX	A/D	PWM	Operating Voltage (V)	Operating Frequency (MHz)	Temp (Note)	Packaging	OTP or Flash Equiv.	Status	Additional Information	Documentation
MC9S12C128	n/a	4	128 Flash	0	8-CH, 16-Bit IC, OC or PWM	Up to 60	SCI SPI	CAN	8-CH, 10-Bit	See Timer	3.0-5.0	25	C, V, M	48-pin QFP (FA) 52-pin QFP (FB) 80-pin QFP (FU)	n/a	Available	www.freescale.com	9S12C128DGV1
MC9S12C96			96 Flash															MC9S12DP512/D CPU12RM/AD
MC9S12C64			64 Flash															
MC9S12C32		2	32 Flash	n/a	8-CH, 16-bit ECT	Up to 59	2 SCI 1 SPI	CAN	7-CH, 8-bit or 3-CH, 16-bit	3.15, 5.5	16, 25	C, M	80-pin QFP (FU)	Available		www.freescale.com	9S12C32D6V1/D CPU12RM/AD	
MC9S12D32				1														
MC9S12DB128B		8	128 Flash	2	8-CH, 16-bit IC, OC, PA	Up to 91	2 SCI 2 SPI	1 CAN Byteflight	2 x 8-CH, 10-bit	8-CH, 8-bit or 4-CH, 16-bit	25.0	C, V, M	80-pin QFP (FU) 112-pin LQFP (PV)	Samples Available		The 80 QFP differs from the 112 LQFP in that it offers only up to 59 I/O, has 1 x 8-CH A/D, and has 7-CH PWM	9S12DT128BDGV1/D CPU12RM/AD	
MC9S12DG128B								2 CAN										
MC9S12DJ128B		8	128 Flash	2	8-CH, 16-bit IC, OC, PA	Up to 91	2 SCI 2 SPI IIC	2 CAN and 1 x J1850	2 x 8-CH, 10-bit	8-CH, 8-bit or 4-CH, 16-bit	5.0	C, V, M	80-pin QFP (FU) 112-pin LQFP (PV)	Samples Available		The 80 QFP differs from the 112 LQFP in that it offers only up to 59 I/O, has 1 x 8-CH A/D, and has 7-CH PWM	9S12DT128BDGV1/D CPU12RM/AD	
MC9S12DP512								3 CAN										
MC9S12DP512		14	512 Flash	n/a	8-CH, 16-bit ECT	Up to 91	2 SCI 3 SPI I ² C	5 CAN	2 x 8-CH, 10-bit	8-CH, 8-bit or 4-CH, 16-bit	25, 33	25, 33	C, V, M	112-pin LQFP (PV)		Available	www.freescale.com	MC9S12DP512/D CPU12RM/AD
MC9S12DT128B	8	128 Flash	2	8-CH, 16-bit IC, OC, PA	Up to 91	2 SCI 2 SPI IIC	3 CAN	2 x 8-CH, 10-bit	8-CH, 8-bit or 4-CH, 16-bit	25.0	25.0	C, V, M	112-pin LQFP (PV)	Samples Available	www.freescale.com	9S12DT128BDGV1/D CPU12RM/AD		

~~COST REDUCER~~ CAN MCUs (CBK/MICRO) CONTROLLERS (continued)

HCS12 Dx and A Family devices offer pin-for-pin compatibility.

For complete part number information and temperature definitions, refer to "Product Numbering System for HCS12" on page SG1006-17.

Product	ROM (Bytes)	RAM (KB)	Flash or OTP (KB)	EEPROM (KB)	Timer	I/O	Serial	MUX	A/D	PWM	Operating Voltage (V)	Operating Frequency (MHz)	Temp (Note)	Packaging	OTP or Flash Equiv.	Status	Additional Information	Documentation			
MC9S12DG256B	n/a	12	256 Flash	4	8-CH, 16-bit IC, OC, PA	Up to 91	2 SCI 3 SPI IIC	2 CAN	2 x 8-CH, 10-bit	8-CH, 8-bit or 4-CH, 16-bit	5.0	25.0	C, V, M	112-pin LQFP (PV)	n/a	Samples Available	www.freescale.com	9S12DP256BDGV2/D CPU12RM/AD			
MC9S12DJ256B								2 CAN and 1 x J1850						80-pin QFP (FU) 112-pin LQFP (PV)			www.freescale.com				
MC9S12DP256B								5 CAN						112-pin LQFP (PV)							
MC9S12DT256B								3 CAN													
MC9S12H128B			128 Flash			99 plus 18 inputs	SCI SPI IIC	2 CAN	16-CH, 10-bit	6-CH, 8-bit or 3-CH, 16-bit				16.0			V	C, V, M	112-pin LQFP (PV) 144-pin LQFP (FV)	www.freescale.com	9S12H256BDGV1/D CPU12RM/AD
MC9S12H256B			256 Flash					2.0A/2.0B													

683xxx Family CAN MCUs

Product	ROM (KB)	RAM (KB)	Flash (Bytes)	Product Integration	Timer	Serial	A/D	Operating Voltage (V)	Operating Frequency (MHz)	Temp (Note)	Packaging	Status	Additional Information	Documentation
MC68376	8	4 + 3.5	0	SIM	TPU CTM4	TouCAN, SCI, queued SPI	Queued 16-CH 10-bit	5.0	20, 25	C, V, M	160-pin QFP	Available	www.freescale.com	MC68336/376PP MC68336/376UM

Note: M = -40°C to 125°C, C= -40°C to 85°C, V = -40°C to 105°C.

CONTROLLER AREA NETWORK MICROCONTROLLERS (continued)
MPC500 Family CAN MCUs

Product	ROM (Bytes)	RAM (KB)	Flash (Bytes)	Product Integration	Timer	Serial	MUX	A/D	PWM	Operating Voltage (V)	Operating Frequency (MHz)	Temp (Note)	Packaging	Status	Additional Information	Documentation
MPC533	0	32	512K	USIU	22-channel timer system; MIOS14	QSMCM (2SCI + QSPI) +1 TouCAN	1 x TouCAN	1 QADC (10-bit A/D with 64 result registers) 32 channels on chip	12 x PWM	2.6, 5.0	40	C	388-ball PBGA	Available	www.freescale.com	MPC533UM MPC533PB
MPC534								Offers code compression								
MPC535		www.freescale.com														
MPC536		Offers code compression														
MPC555		26 + 6 for TPU	448K		50-channel timer system; 2 TPU3 + MIOS1	QSMCM (2 SCI + QSPI) + 2 TouCAN	2 x TouCAN	8 x PWM	3.3 Vdc for core, 5.0 Vdc for Flash	A, C, M	272-ball PBGA	www.freescale.com	MPC555UM TPURM RCPURM			
MPC561		32 + 8 for TPU + 2 for DECRAM	0		54-channel timer system; 2 TPU3 + MIOS14	QSMCM (2 SCI + 1 QSPI) + 3 TouCAN	3 x TouCAN	12 x PWM	2.6 Vdc for core, 5.0 Vdc for A/D and I/O	2 QADC (10-bit A/D with 64 result registers) 32 channels on chip	40, 56, 66	C, M	388-ball PBGA		Offers code compression	MPC561RM TPURM RCPURM
MPC562															www.freescale.com	MPC563RM TPURM RCPURM
MPC563															Offers code compression	
MPC564															www.freescale.com	MPC566UM TPURM RCPURM
MPC565		36 + 10 for TPU + 4 for DECRAM	1M		70-channel timer system; 3 TPU3 + MIOS14	QSMCM x 2 (4 SCI + 2 QSPI) + 3 TouCAN	3 x TouCAN 1 x J1850	2 QADC (10-bit A/D with 64 result registers) 40 channels on chip	40 or 56	A, C, M	Offers code compression					
MPC566																

Note: A = -55°C to 125°C, C = -40°C to 85°C, and M = -40°C to 125°C.

DSP56800 Family CAN MCUs

Product	Performance	Program ROM/RAM/Flash	Data ROM/RAM/Flash	Peripherals	Packaging	Additional Information
DSP56F803BU80	80 MHz	n/a/512/32K	n/a/2K/4K	CAN, SCI, SPI, ADC, PWM, Quadrature Decoder, Quad Timer	100-pin LQFP	MCU-friendly instruction set, OnCE for debug, 2K Boot Flash, external memory expansion available, up to 16 GPIO. Order two-unit sample pack as SPAK56F803BU80. S, MOQ of 90.
DSP56F805FV80					144-pin LQFP	MCU-friendly instruction set, OnCE for debug, 2K Boot Flash, external memory expansion available, up to 32 GPIO. SPAK56F805FV80. S, MOQ of 60.
DSP56F807PY80 (LQFP) DSP56F807VF80 (MAPBGA)		n/a/2K/60K	n/a/2K/8K		160-pin LQFP 160-ball MAPBGA	MCU-friendly instruction set, OnCE for debug, 2K Boot Flash, external memory expansion available, up to 32 GPIO. MOQ of 60 for LQFP. SPAK56F807PY80 or SPAK56F807VF80. MOQ of 24 for MAPBGA.

LOCAL AREA NETWORK MICROCONTROLLERS

LIN Slave MCUs

Product	ROM (KB)	RAM (Bytes)	Flash or OTP (KB)	EEPROM (Bytes)	Timer	I/O	Serial	A/D	PWM	COP	Operating Voltage (V)	Max Bus Freq (MHz)	Temp (Note)	Packaging	OTP or Flash Equiv.	Status	Additional Information	Documentation
MC68HC08AB16A	16	512	n/a	512	4-CH + 4-CH, 16-bit IC, OC, or PWM	51	SCI SPI	8-CH, 8-bit	See Timer	Y	5.0	8.0	C, M	64-pin QFP (FU)	908AB32	Available	Programmable interrupt timer module.	MC68HC08AB16A/D
MC68HC908AB32	n/a	1K	32 Flash												2-CH + 2-CH, 16-bit I/C, O/C, or PWM		24	ESCI SPI
MC68HC908EY16	n/a	512	16 Flash	n/a	2-CH, 16-bit IC, OC, or PWM	23	n/a	12-CH, 8-bit	See Timer	Y	3.0, 5.0	8.0 Max	C, V, M	32-pin QFP (FA)	n/a	Production	RC oscillator option, LVR with selectable trip points, 6-pin LED drive. Sample pack part numbers: KMC908JL3CP, KMC908JL3CDW, KMCR908JL3CP, KMCR908JL3CDW	MC68HC908JL3/H
MC68HC908JL3	n/a	4 Flash	2-CH, 16-bit IC, OC, or PWM															
MC68HC08JL3	4	128	n/a	n/a	2-CH, 16-bit IC, OC or PWM	13	SLIC (LIN)	6-CH, 10-bit	See Timer	Y	3.0, 5.0	8.0	C, M	28-pin DIP (P) 28-pin SOIC (DW) 48-pin LQFP (FA)	908JL3	Available	RC oscillator option: 68HRC08JL3, LVR with selectable trip points, 6-pin LED drive.	MC68HC908JL3/H
MC908QL4	n/a	4	n/a												2-CH, 16-bit IC, OC or PWM		13	
MC908QL3	n/a	4	n/a	n/a	2-CH, 16-bit IC, OC or PWM	13	SLIC (LIN)	6-CH, 10-bit	See Timer	Y	3.0, 5.0	8.0	C, V, M	16-pin TSSOP (DT) 16-pin SOIC (DW)	n/a	Available	SLIC (Slave-LIN Interface Controller) featuring Autobauding/Auto Synchronization	MC68HC908QL4
MC908QL2	n/a	2	n/a														2-CH, 16-bit IC, OC or PWM	

Note: C = -40°C to 85°C, M = -40°C to 125°C, and V = -40°C to 105°C.

68HC08 LIN Master MCUs

Product	ROM (KB)	RAM (KB)	Flash or OTP (KB)	EEPROM (Bytes)	Timer	I/O	Serial	A/D	PWM	COP	Operating Voltage (V)	Max Bus Freq (MHz)	Temp (Note)	Packaging	OTP or Flash Equiv.	Status	Additional Information	Documentation
XC68HC08AZ32	32	1	n/a	512	4-CH + 2-CH, 16-bit IC, OC, or PWM	40/50	SCI SPI CAN	8-CH or 15-CH, 8-bit	See Timer	Y	5.0	8.4	C, V, M	64-pin QFP (FU) 52-pin PLCC (FN)	908AZ60A	Available	CAN 2.0A and 2.0B	MC68HC08AZ32
MC908AZ60A	n/a	2	60 Flash	1K	6-CH + 2-CH, 16-bit IC, OC, or PWM	50		15-CH, 8-bit						64-pin QFP (FU)	n/a		MC908AZ60A is pin-for-pin compatible replacement for MC68HC908AZ60. CAN 2.0A and 2.0B	MC68HC908AZ60A

Note: C = -40°C to 85°C, M = -40°C to 125°C, and V = -40°C to 105°C.

LOCAL AREA NETWORK MICROCONTROLLERS (continued)

68HC12 LIN Master MCUs

Product	ROM (KB)	RAM (KB)	Flash (KB)	EEPROM (Bytes)	Timer	I/O	Serial	A/D	PWM	Operating Voltage (V)	Max Bus Frequency (MHz)	Temp (Note)	Packaging	Status	Additional Information	Documentation
MC68HC912B32	n/a	1	32	768	8-CH, 16-bit IC or OC RTI, pulse accumulator	Up to 63	SCI, SPI J1850	8-CH, 10-bit	4-CH, 8-bit or 2-CH, 16-bit	5.0	8.0	C, V, M	80-pin QFP (FU)	Available	J1850, muxed bus, BDM. Sample pack part numbers: KMC912B32CFU/VFU/MFU	MC68HC912B/D
MC68HC12BE32	32		n/a									C			BDM, enhanced timer Evaluation Product with on-chip monitor: XC12BE32DCFU8. Sample pack part number: KXC12BE32DCFU8	
MC912D60A	n/a	2	60	1K	8-CH, 16-Bit	Up to 66 I/O and 18 i	Dual SCI SPI, CAN	Dual 8-CH, 10-Bit				C, V, M	80-pin QFP (FU) 112-pin LQFP (PV)	Available	Replaces the XC68HC912D60 with 5 V Flash voltage and a different programming algorithm.	MC68HC912D60/D
XC68HC12D60	60		n/a				Dual SCI SPI								Part equipped with CAN 2.0A/B.	
MC912DG128A	n/a	8	128	2K	8-CH, 16-Bit IC or OC RTI, pulse accumulator	Up to 67 I/O and 18 i	Dual SCI SPI, CAN	8-CH or 16-CH, 10-Bit				C, V, M	112-pin LQFP (PV)	Available	Replaces the XC912DG128 with 5 V Flash voltage and a different programming algorithm.	MC68HC912DG128/D
MC68HC912DT128A					8-CH, 16-Bit		Up to 66 I/O and 18 i								Dual SCI, SPI	

Note: C = -40°C to 85°C, M = -40°C to 125°C, and V = -40°C to 105°C.

UNIVERSAL SERIAL BUS MICROCONTROLLERS (continued)

68HC08 Family USB MCUs

Product	ROM (Bytes)	RAM (Bytes)	Flash or OTP (Bytes)	EEPROM (Bytes)	Timer	I/O	Serial	A/D	PWM	COP	Operating Voltage (V)	Max Bus Freq (MHz)	Temp	Packaging	OTP or Flash Equiv.	Status	Additional Information	Documentation
MC68HC08JB1	5.5K	128	n/a	n/a	2-CH, 16-bit IC, OC, or PWM	13	USB PS/2	n/a	See Timer	Y	5.0	3.0	0°C to 70°C only	20-pin DIP (P) 20-pin SOIC (JDW)	908JB8	Available	Supports both USB and PS/2; 1.5Mbps USB with 2 endpoints, low voltage reset, keyboard interrupt, 3.3 V bandgap reference	n/a
MC68HC908JB8	n/a	256	8K Flash			Up to 37	USB							20-pin DIP (P) 28-pin SOIC (DW) 44-pin QFP (FB)	n/a		Complies with USB 1.1 specification for low-speed USB (1.5Mbps) On-chip 3.3 V regulator	MC68HC908JB8/D
MC68HC908JB12		384	12K Flash		Up to 21	SCI USB 2.0	20-pin SOIC (DW) 28-pin SOIC (DW)				n/a	www.freescale.com		n/a				
MC68HC08JB8	8K	256	n/a		Dual 2-CH, 16-bit IC, OC, or PWM	Up to 37	USB				4.0 to 5.5	3.0		20-pin PDIP (JP) 20-pin SOIC (JDW) 28-pin SOIC (ADW) 44-pin QFP (FB)	908JB8		Complies with USB 1.1 specification for low-speed USB (1.5Mbps), LVI	MC68HC908JB8/D
MC68HC08KH12	12K	384									42	3.3 V		6.0	64-pin QFP (FU)		708KH12	PC keyboard/hub 12mbs USB (1 up, 4 down) 5 LED direct drive port pins

MOTOR CONTROL MICROCONTROLLERS

Motor Control Unit Product Table

Product	COP	Operating Voltage (V)	Max Bus Frequency (MHz)	Temp	Packaging	OTP	Status	Additional Information	Documentation
MC3PHAC	Y	5.0	4.0	V	32-pin LQFP (FA) 28-pin SOIC (DW) 28-pin PDIP (P)	n/a	Samples Available	A complete solution, contains all functions required to implement control of open loop 3-phase AC motor drive	MC3PHAC DRM006

ZIGBEE™ -READY PLATFORM

ZigBee-Ready and Proprietary RF Transceivers

Product	Data Rate (kbps)	Operating Voltage (V)	Band (MHz)	MCU Interface	Packaging	Status	Additional Information
MC13191FCR2	250 max	2.4 to 3.4	2.4 GHz	SPI	32-pin QFN 5 x 5	Available	2.4 GHz Proprietary RF transceiver data modem for Point-to-Point and Star applications
MC13192FCR2							2.4 GHz RF transceiver data modem for ZigBee™ applications

PACKAGING
(Actual Size)

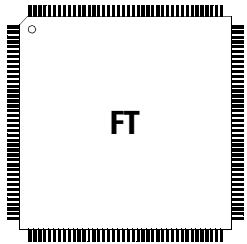

FT
208/160-Pin QFP
.65 mm Pitch
28 mm x 28 mm Body

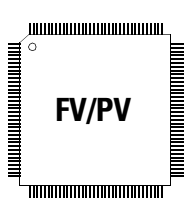

FV/PV
144-Pin LQFP/QFP
.5 mm Pitch
20 mm x 20 mm Body

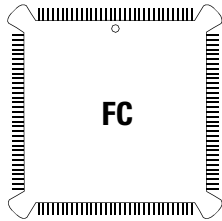

FC
132-Pin PQFP
25 mil/06.35 mm Pitch
0.950 in x 0.950 in Body
(Nominal, w.o. Bumpers)

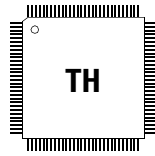

TH
120-Pin QFP/LQFP
.5 mm Pitch
16 mm x 16 mm Body

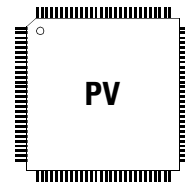

PV
112-Pin LQFP
.65 mm Pitch
20 mm x 20 mm Body

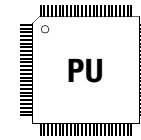

PU
100-Pin LQFP
.5 mm Pitch
14 mm x 14 mm Body

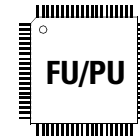

FU/PU
80-Pin QFP/LQFP
.65 mm Pitch
14 mm x 14 mm Body



TU
80-Pin TQFP-EP
.65 mm Pitch
14 mm x 14 mm Body

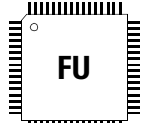

FU
64-Pin QFP
.8 mm Pitch
14 mm x 14 mm Body

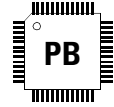

PB
52-Pin LQFP
.65 mm Pitch
10 mm x 10 mm Body

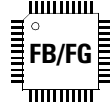

FB/FG
44-Pin QFP/LQFP
.8 mm Pitch
10 mm x 10 mm Body



FD
48-Pin QFN
.5 mm Pitch
7 mm x 7 mm Body



FJ
32-Pin LQFP
.8 mm Pitch
7 mm x 7 mm Body



FA
48-Pin LQFP
.5 mm Pitch
7 mm x 7 mm Body



FQ
8-Pin DFN
4 mm x 4 mm Body

Packaging Designators

- B – Shrink DIP (70 mil spacing)
- DT – Thin Shrink Small Outline Package
- DW – Small Outline (Wide-Body SOIC)
- FA – 7 x 7 mm Quad Flat Pack (QFP)
- FB – 10 x 10 mm Quad Flat Pack (QFP)
- FC – Plastic Quad (Gull Wing)
- FE – CQFP (windowed) n/a Samples Only
- FG – 14 x 20 mm Plastic Quad Flat Pack (PQFP)
- FN – Plastic Quad (PLCC)
- FQ – Dual Flat No Load (DFN)
- FS – CLCC (windowed) n/a Samples Only
- FT – 28 x 28 mm Quad Flat Pack (QFP)
- FU – 14 x 14 mm Quad Flat Pack (QFP)
- FZ – CQFP (windowed) n/a Samples Only
- K – Cerdip (windowed) n/a Samples Only
- L – Ceramic Sidebrazed
- P – Dual in-Line Plastic
- PB – 10 x 10 mm Quad Flat Pack (QFP)
- PU – 14 x 14 mm Low-Profile Quad Flat Pack (LQFP)
- PV – 20 x 20 mm Low-Profile Quad Flat Pack (LQFP)
- RC – Pin Grid Array, Gold Lead Finish
- S – Cerdip (windowed) n/a Samples Only
- SD – Shrink Small Outline Package (SSOP)
- VF – 1.6 mm Thick MAPBGA
- ZP – Plastic Ball Grid Array (PBGA)
- ZU – Tape Ball Grid Array, 352 and 480 Lead



DW
28-Pin SOIC
50 mil/1.27 mm Pitch
18.0 mm x 7.5 mm Body

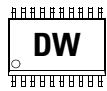

DW
20-Pin SOIC
50 mil/1.27 mm Pitch
12.8 mm x 7.5 mm Body



DW
16-Pin SOIC
50 mil/1.27 mm Pitch
10.35 mm x 7.5 mm Body



DW
8-Pin SOIC
50 mil/1.27 mm Pitch
5.3 mm x 7.5 mm Body

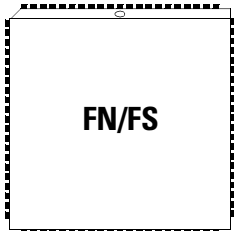

FN/FS
84-Pin PLCC/CLCC
50 mil/1.27 mm Pitch
1.15 in x 1.15 in Body

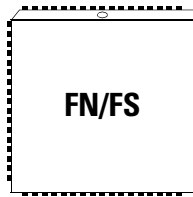

FN/FS
68-Pin PLCC/CLCC
50 mil/1.27 mm Pitch
0.950 in x 0.950 in Body

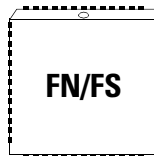

FN/FS
52-Pin PLCC/CLCC
50 mil/1.27 mm Pitch
0.750 in x 0.750 in Body

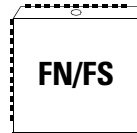

FN/FS
44-Pin PLCC/CLCC
50 mil/1.27 mm Pitch
0.650 in x 0.650 in Body

PACKAGING

PACKAGING (continued) (Actual Size)



28-Pin SSOP

25.6 mil/.65 mm Pitch
5.28 mm x 10.19 mm Body



20-Pin SSOP

17 mil/.65 mm Pitch
5.3 mm x 7.2 mm Body



16-Pin TSSOP

25 mil/.64 mm Pitch
5.0 mm x 4.4 mm Body

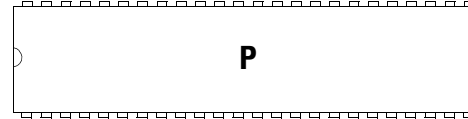

48-Pin Plastic DIP

100 mil/2.54 mm Pitch
2.45 in x .55 in Body
(100 mil x 600 mil pin centers)

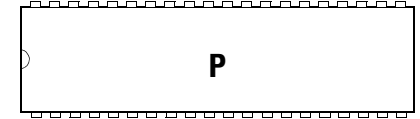

40-Pin Plastic DIP

100 mil/2.54 mm Pitch
2.05 in x .55 in Body
(100 mil x 600 mil pin centers)

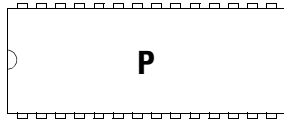

28-Pin DIP

100 mil/2.54 mm Pitch
1.45 in x .55 in Body
(100 mil x 600 mil pin centers)

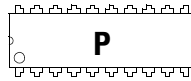

20-Pin Plastic DIP

100 mil/2.54 mm Pitch
.97 in x .29 in Body
(100 mil x 300 mil pin centers)

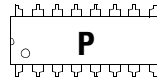

16-Pin Plastic DIP

100 mil/2.54 mm Pitch
.75 in x .25 in Body
(100 mil x 300 mil pin centers)



8-Pin Plastic DIP

100 mil/2.54 mm Pitch
.38 in x .25 in Body
(100 mil x 300 mil pin centers)

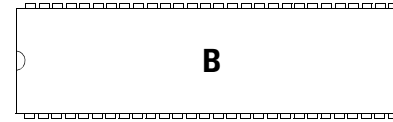

56-Pin Plastic SDIP

70 mil/1.778 mm Pitch
2.05 in x .55 in Body
(70 mil x 600 mil pin centers)

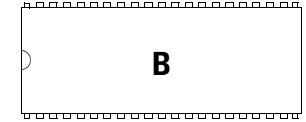

42-Pin Plastic SDIP

70 mil/1.778 mm Pitch
1.45 in x .55 in Body
(70 mil x 600 mil pin centers)

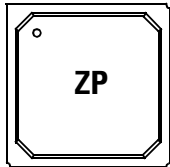

272-Ball PBGA

1.27 mm Pitch
27.0 mm x 27.0 mm Body

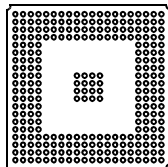

144-Ball Grid Array (BGA)

.8 mm Ball Pitch
12 mm x 12 mm x 1.6 mm

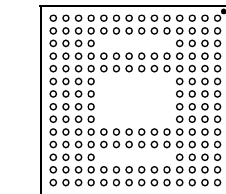
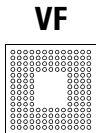

160-Ball Plastic MAPBGA

VF

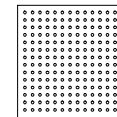

196-Ball MAPBGA

1 mm Pitch
15 mm x 15 mm Body

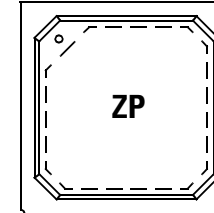

388-Ball PBGA

1 mm Pitch
27.0 mm x 27.0 mm Body

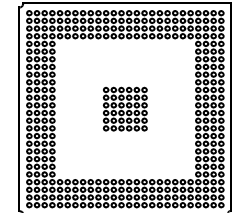

NOTES

NOTES

NOTES

How to Reach Us:

Home Page:

www.freescale.com

E-mail:

support@freescale.com

USA/Europe or Locations Not Listed:

Freescale Semiconductor
Technical Information Center, CH370
1300 N. Alma School Road
Chandler, Arizona 85224
+1-800-521-6274 or +1-480-768-2130
support@freescale.com

Europe, Middle East, and Africa:

Freescale Halbleiter Deutschland GmbH
Technical Information Center
Schatzbogen 7
81829 Muenchen, Germany
+44 1296 380 456 (English)
+46 8 52200080 (English)
+49 89 92103 559 (German)
+33 1 69 35 48 48 (French)
support@freescale.com

Information in this document is provided solely to enable system and software implementers to use Freescale Semiconductor products. There are no express or implied copyright licenses granted hereunder to design or fabricate any integrated circuits or integrated circuits based on the information in this document.

Freescale Semiconductor reserves the right to make changes without further notice to any products herein. Freescale Semiconductor makes no warranty, representation or guarantee regarding the suitability of its products for any particular purpose, nor does Freescale Semiconductor assume any liability arising out of the application or use of any product or circuit, and specifically disclaims any and all liability, including without limitation consequential or incidental damages. "Typical" parameters that may be provided in Freescale Semiconductor data sheets and/or specifications can and do vary in different applications and actual performance may vary over time. All operating parameters, including "Typicals", must be validated for each customer application by customer's technical experts.

Japan:

Freescale Semiconductor Japan Ltd.
Headquarters
ARCO Tower 15F
1-8-1, Shimo-Meguro, Meguro-ku
Tokyo 153-0063
Japan
0120 191014 or +81 3 5437 9125
support.japan@freescale.com

Asia/Pacific:

Freescale Semiconductor Hong Kong Ltd.
Technical Information Center
2 Dai King Street
Tai Po Industrial Estate
Tai Po, N.T., Hong Kong
+800 2666 8080
support.asia@freescale.com

Freescale Semiconductor does not convey any license under its patent rights nor the rights of others. Freescale Semiconductor products are not designed, intended, or authorized for use as components in systems intended for surgical implant into the body, or other applications intended to support or sustain life, or for any other application in which the failure of the Freescale Semiconductor product could create a situation where personal injury or death may occur. Should Buyer purchase or use Freescale Semiconductor products for any such unintended or unauthorized application, Buyer shall indemnify and hold Freescale Semiconductor and its officers, employees, subsidiaries, affiliates, and distributors harmless against all claims, costs, damages, and expenses, and reasonable attorney fees arising out of, directly or indirectly, any claim of personal injury or death associated with such unintended or unauthorized use, even if such claim alleges that Freescale Semiconductor was negligent regarding the design or manufacture of the part.

For Literature Requests Only:

Freescale Semiconductor Literature Distribution Center
P.O. Box 5405
Denver, Colorado 80217
1-800-441-2447 or 303-675-2140
Fax: 303-675-2150
LDCForFreescaleSemiconductor@hibbertgroup.com