



MIL-PRF-19500/255N

1.4 Primary electrical characteristics at  $T_A = +25^\circ\text{C}$ .

		h <sub>FE</sub> at V <sub>CE</sub> = 10 V dc									
		h <sub>FE1</sub> I <sub>C</sub> = 0.1 mA dc		h <sub>FE2</sub> I <sub>C</sub> = 1.0 mA dc		h <sub>FE3</sub> I <sub>C</sub> = 10 mA dc		h <sub>FE4</sub> (1) I <sub>C</sub> = 150 mA dc		h <sub>FE5</sub> (1) I <sub>C</sub> = 500 mA dc	
		L, UA, UB 2N2221A 2N2222A		L, UA, UB 2N2221A 2N2222A		L, UA, UB 2N2221A 2N2222A		L, UA, UB 2N2221A 2N2222A		L, UA, UB 2N2221A 2N2222A	
Min		30	50	35	75	40	100	40	100	20	30
Max				150	325			120	300		

Types	Limit	h <sub>fe</sub>   f = 100 MHz V <sub>CE</sub> = 20 V dc I <sub>C</sub> = 20 mA dc	C <sub>obo</sub> 100 kHz ≤ f ≤ 1 MHz V <sub>CB</sub> = 10 V dc I <sub>E</sub> = 0	Switching (saturated)	
				t <sub>on</sub> See figure 7	t <sub>off</sub> See figure 8
2N2221A, 2N2222A L, UA, UB	Min Max	2.5	pF 8	ns 35	ns 300

Types	Limit	V <sub>CE(sat)1</sub> (1) I <sub>C</sub> = 150 mA dc I <sub>B</sub> = 15 mA dc	V <sub>CE(sat)2</sub> (1) I <sub>C</sub> = 500 mA dc I <sub>B</sub> = 50 mA dc	V <sub>BE(sat)1</sub> (1) I <sub>C</sub> = 150 mA dc I <sub>B</sub> = 15 mA dc	V <sub>BE(sat)2</sub> (1) I <sub>C</sub> = 500 mA dc I <sub>B</sub> = 50 mA dc
2N2221A, 2N2222A L, UA, UB	Min Max	V dc 0.3	V dc 1.0	V dc 0.6 1.2	V dc 2.0

(1) Pulsed see 4.5.1.

Symbol	Dimensions				Note
	Inches		Millimeters		
	Min	Max	Min	Max	
CD	.178	.195	4.52	4.95	
CH	.170	.210	4.32	5.33	
HD	.209	.230	5.31	5.84	
LC	.100 TP		2.54 TP		6
LD	.016	.021	0.41	0.53	7,8
LL	.500	.750	12.70	19.05	7,8,13
LU	.016	.019	0.41	0.48	7,8
L1		.050		1.27	7,8
L2	.250		6.35		7,8
P	.100		2.54		
Q		.030		0.76	5
TL	.028	.048	0.71	1.22	3,4
TW	.036	.046	0.91	1.17	3
r		.010		0.25	10
$\alpha$	45° TP		45° TP		6
1, 2, 9, 11, 12, 13					

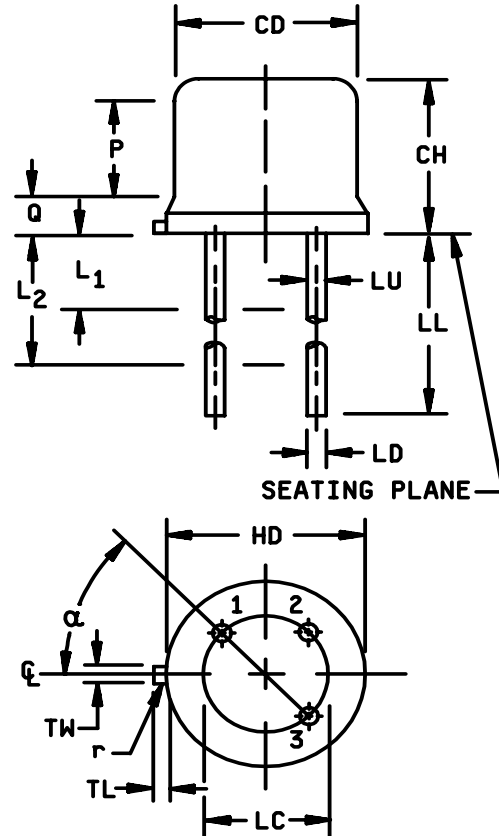

NOTES:

1. Dimensions are in inches.
2. Metric equivalents are given for general information only.
3. Beyond r (radius) maximum, TL shall be held for a minimum length of .011 inch (0.28 mm).
4. Dimension TL measured from maximum HD.
5. Body contour optional within zone defined by HD, CD, and Q.
6. Leads at gauge plane .054 +.001 -.000 inch (1.37 +0.03 -0.00 mm) below seating plane shall be within .007 inch (0.18 mm) radius of true position (TP) at maximum material condition (MMC) relative to tab at MMC. The device may be measured by direct methods or by the gauge and gauging procedure shown in figure 2.
7. Dimension LU applies between L<sub>1</sub> and L<sub>2</sub>. Dimension LD applies between L<sub>2</sub> and LL minimum. Diameter is uncontrolled in L<sub>1</sub> and beyond LL minimum.
8. All three leads.
9. The collector shall be internally connected to the case.
10. Dimension r (radius) applies to both inside corners of tab.
11. In accordance with ANSI Y14.5M, diameters are equivalent to  $\phi$ x symbology.
12. Lead 1 = emitter, lead 2 = base, lead 3 = collector.
13. For L suffix devices, dimension LL = 1.5 inches (38.10 mm) min. and 1.75 inches (44.45 mm) max.

\* FIGURE 1. Physical dimensions (similar to TO-18).

MIL-PRF-19500/255N

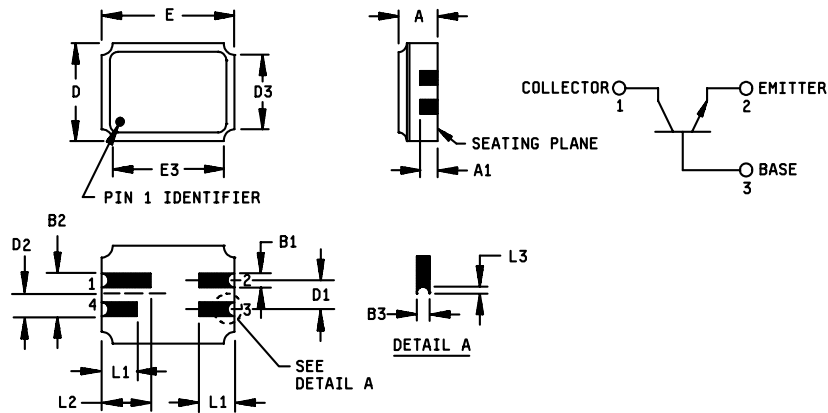

Symbol	Dimensions				Note
	Inches		Millimeters		
	Min	Max	Min	Max	
A	.061	.075	1.55	1.90	3
A1	.029	.041	0.74	1.04	
B1	.022	.028	0.56	0.71	
B2	.075 REF		1.91 REF		
B3	.006	.022	0.15	0.56	5
D	.145	.155	3.68	3.93	
D1	.045	.055	1.14	1.39	
D2	.0375 BSC		.952 BSC		
D3		.155		3.93	
E	.215	.225	5.46	5.71	
E3		.225		5.71	
L1	.032	.048	0.81	1.22	
L2	.072	.088	1.83	2.23	
L3	.003	.007	0.08	0.18	5

NOTES:

1. Dimensions are in inches.
2. Metric equivalents are given for general information only.
3. Dimension "A" controls the overall package thickness. When a window lid is used, dimension "A" must increase by a minimum of .010 inch (0.254 mm) and a maximum of .040 inch (1.020 mm).
4. The corner shape (square, notch, radius, etc.) may vary at the manufacturer's option, from that shown on the drawing.
5. Dimensions "B3" minimum and "L3" minimum and the appropriately castellation length define an unobstructed three-dimensional space traversing all of the ceramic layers in which a castellation was designed. (Castellations are required on bottom two layers, optional on top ceramic layer.) Dimension "B3" maximum and "L3" maximum define the maximum width and depth of the castellation at any point on its surface. Measurement of these dimensions may be made prior to solder dipping.

FIGURE 2. Physical dimensions, surface mount (UA version).

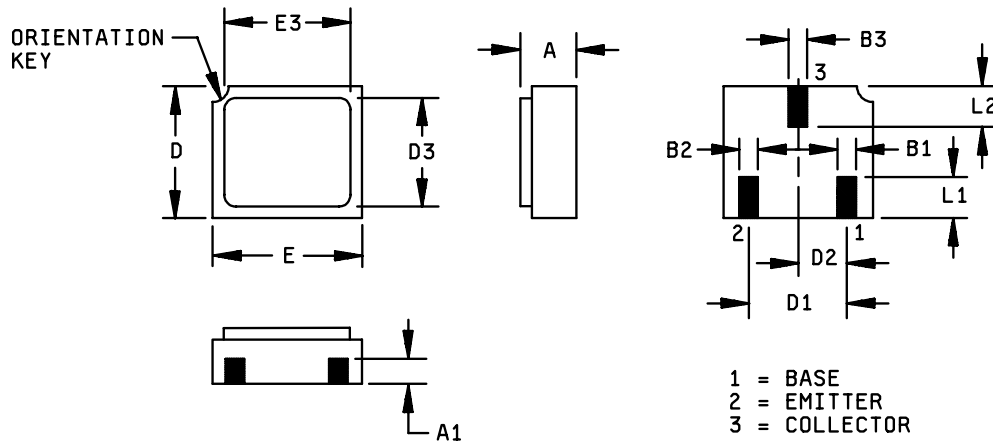

Symbol	Dimensions				Note
	Inches		Millimeters		
	Min	Max	Min	Max	
A	.046	.056	0.97	1.42	
A1	.017	.035	0.43	0.89	
B1	.016	.024	0.41	0.61	
B2	.016	.024	0.41	0.61	
B3	.016	.024	0.41	0.61	
D	.085	.108	2.41	2.74	
D1	.071	.079	1.81	2.01	
D2	.035	.039	0.89	0.99	
D3	.085	.108	2.41	2.74	
E	.115	.128	2.82	3.25	
E3		.128		3.25	
L1	.022	.038	0.56	0.96	
L2	.022	.038	0.56	0.96	

NOTES:

1. Dimensions are in inches.
2. Metric equivalents are given for general information only.

FIGURE 3. Physical dimensions, surface mount (UB version).

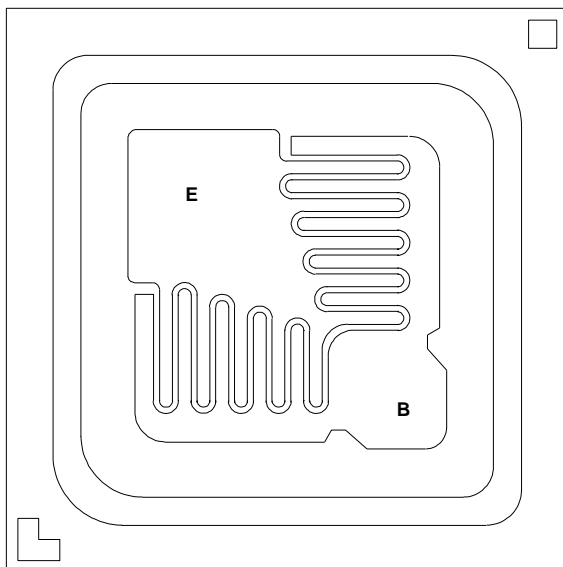

Physical characteristics:  
B-version

Chip size:	0.023 x 0.023 mils ± 0.002 mils.
Chip thickness:	0.010 ± 0.0015 mils.
Top metal:	Aluminum 15,000Å minimum, 18,000Å nominal.
Back metal:	A. Al/Ti/Ni/Ag 15kÅ/5kÅ/10kÅ/10kÅ. B. Gold 2,500Å minimum, 3,000Å nominal. C. Eutectic die mount - no metal.
Glassivation:	Si <sub>3</sub> N <sub>4</sub> 2,000 Å minimum, 8,000 Å nominal.
Backside:	Collector.
Bonding pad:	B = 0.0042 x 0.0042 mils, E = 0.0042 x 0.0042 mils.

FIGURE 4. JANHC and JANKC (B-version) die dimensions.

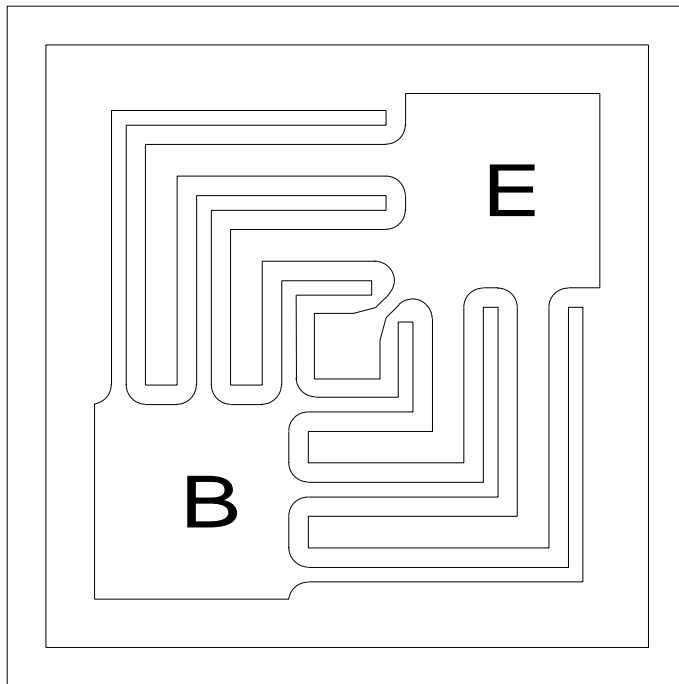

Die size:	.020 x .020 inch (0.508 mm x 0.508 mm).
Die thickness:	.008 ±.0016 inch (0.2032 mm ±0.04064 mm).
Base bonding pad:	.004 x .004 inch (0.1016 mm x 0.1016 mm).
Emitter bonding pad:	.004 x .004 inch.
Back metal:	Gold, 6,500 ±1950 Å.
Top metal:	Aluminum, 27,000 ±3,000 Å.
Back side:	Collector.
Glassivation:	SiO <sub>2</sub> , 7,500 ±1,500 Å.

FIGURE 5. JANHC and JANKC (C-version) die dimensions.

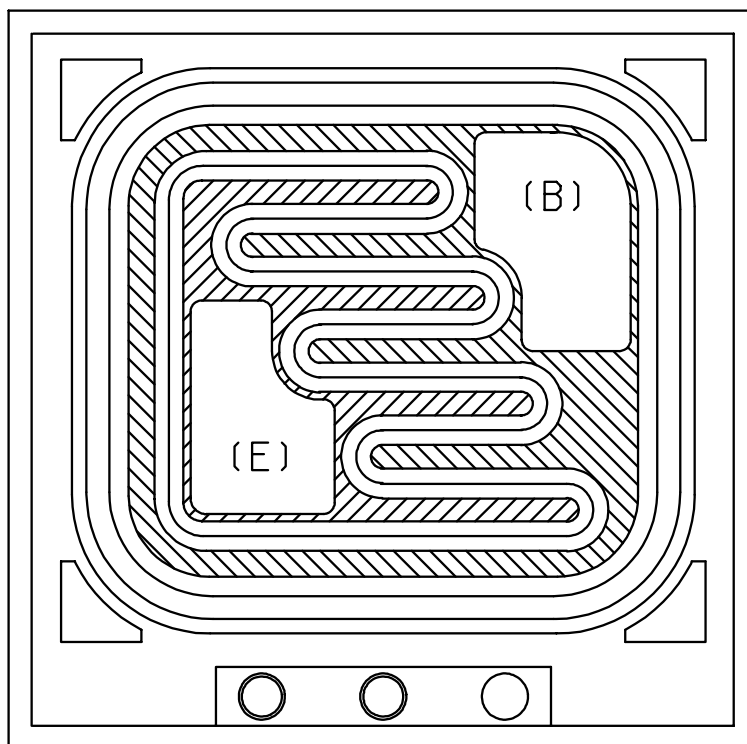

Die size.	.0198 x .0198 inch $\pm$ .0005 inch (0.50292 x 0.50292 mm $\pm$ 0.0127 mm).
Die thickness	.010 $\pm$ .001 inch (0.254 $\pm$ 0.0254 mm) nominal.
Top metal	Aluminum, 21,000Å nominal.
Back metal	Gold 2,000Å nominal.
Backside	Collector.
Bonding pad	B = .0041 x .0059 inch (0.10414 x 0.14986 mm), E = .0038 x .0057 inch (0.09652 x 0.14478 mm).
Glassivation	Silicon oxide.

FIGURE 6. JANHC and JANKC (D-version for 2N2222A, and 2N2221A) die dimensions.



## 2. APPLICABLE DOCUMENTS

2.1 General. The documents listed in this section are specified in sections 3 and 4 of this specification. This section does not include documents cited in other sections of this specification or recommended for additional information or as examples. While every effort has been made to ensure the completeness of this list, document users are cautioned that they must meet all specified requirements documents cited in sections 3 and 4 of this specification, whether or not they are listed.

### 2.2 Government documents.

2.2.1 Specifications, standards, and handbooks. The following specifications, standards, and handbooks form a part of this document to the extent specified herein. Unless otherwise specified, the issues of these documents are those listed in the issue of the Department of Defense Index of Specifications and Standards (DODISS) and supplement thereto, cited in the solicitation (see 6.2).

#### SPECIFICATION

##### DEPARTMENT OF DEFENSE

MIL-PRF-19500 - Semiconductor Devices, General Specification for.

#### STANDARD

##### DEPARTMENT OF DEFENSE

MIL-STD-750 - Test Methods for Semiconductor Devices.

(Unless otherwise indicated, copies of the above specifications, standards, and handbooks are available from the Document Automation Production Services (DAPS), 700 Robbins Avenue, Building 4D (DPM-DODSSP), Philadelphia, PA 19111-5094)

2.3 Order of precedence. In the event of a conflict between the text of this document and the references cited herein, the text of this document takes precedence. Nothing in this document, however, supersedes applicable laws and regulations unless a specific exemption has been obtained.

## 3. REQUIREMENTS

3.1 General. The requirements for acquiring the product described herein shall consist of this document and MIL-PRF-19500.

3.2 Qualification. Devices furnished under this specification shall be products that are manufactured by a manufacturer authorized by the qualifying activity for listing on the applicable qualified manufacturer's list (QML) before contract award (see 4.2 and 6.3).

3.3 Abbreviations, symbols, and definitions. Abbreviations, symbols, and definitions used herein shall be as specified in MIL-PRF-19500 and as follows.

UA, UB, - - - - - Surface mount case outlines (see figures 2 and 3).

\* 3.4 Interface and physical dimensions. The interface and physical dimensions shall be as specified in MIL-PRF-19500, and on figures 1, 2, 3, 4, 5, and 6 herein.

3.4.1 Lead finish. Lead finish shall be solderable in accordance with MIL-PRF-19500, MIL-STD-750, and herein. Where a choice of lead finish is desired, it shall be specified in the acquisition document (see 6.2).

3.5 Radiation hardness assurance (RHA). Radiation hardness assurance requirements, PIN designators, and test levels shall be as defined in MIL-PRF-19500.

3.6 Electrical performance characteristics. Unless otherwise specified herein, the electrical performance characteristics are as specified in paragraph 1.3, 1.4, and table I.

3.7 Electrical test requirements. The electrical test requirements shall be as specified in table I, subgroup 2.

3.8 Marking. Marking shall be in accordance with MIL-PRF-19500, except for the UB suffix package. Marking on the UB package shall consist of an abbreviated part number, the date code, and the manufacturers symbol or logo. The prefixes JAN, JANTX, JANTXV, JANJ, and JANS can be abbreviated as J, JX, JV, JJ, and JS respectively. The "2N" prefix and the "AUB" suffix can also be omitted.

3.9 Workmanship. Semiconductor devices shall be processed in such a manner as to be uniform in quality and shall be free from other defects that will affect life, serviceability, or appearance.

#### 4. VERIFICATION

4.1 Classification of inspections. The inspection requirements specified herein are classified as follows:

- a. Qualification inspection (see 4.2).
- b. Screening (see 4.3).
- c. Conformance inspection (see 4.4).

4.2 Qualification inspection. Qualification inspection shall be in accordance with MIL-PRF-19500 and 4.4.5 herein.

4.2.1 JANJ devices. For JANJ level, 3.3.1 through 3.3.1.3 of MIL-PRF-19500 shall apply, except as modified herein. Supplier imposed requirements as well as alternate screens, procedures, and/or controls shall be documented in the QM plan and must be submitted to the qualifying activity for approval. When alternate screens, procedures, and/or controls are used in lieu of the JANJ screens herein equivalency shall be proven and documented in the QM plan. Radiation characterization may be submitted in the QM plan at the option of the manufacturer, however, 3.3.1.1 of MIL-PRF-19500 is not required. Die lot controls and rework requirements shall be in accordance with 3.13 of MIL-PRF-19500 and D.3.13.2.1 for JANS level. Lot formation and conformance inspection requirements for JANJ shall be those used for JANTXV devices as a minimum

4.2.2 JANJ qualification. For JANJ qualification, 4.4.2.1 herein shall be performed as required by the qualifying activity. A JANS certified supplier may supply JANJ product utilizing the JANJ screening flow in 4.3 herein.

4.2.3 JANHC and JANKC qualification. JANHC and JANKC qualification inspection shall be in accordance with MIL-PRF-19500.

\* 4.2.4 Group E qualification. Group E inspection shall be performed for qualification or re-qualification only. In case qualification was awarded to a prior revision of the associated specification that did not request the performance of table III tests, the tests specified in table III herein must be performed by the first inspection lot of this revision to maintain qualification.

MIL-PRF-19500/255N

\* 4.3 Screening (JANS, JANJ, JANTX, and JANTXV levels only). Screening shall be in accordance with table IV MIL-PRF-19500, and as specified herein. The following measurements shall be made in accordance with table I herein. Devices that exceed the limits of table I herein shall not be acceptable.

Screen (see table IV of MIL-PRF-19500)	Measurement		
	JANS level	JANJ level	JANTX and JANTXV levels
2	Optional	Optional	Optional
3a 3b 3c	Required Not applicable Thermal impedance, method 3131 of MIL-STD-750	Required Not applicable Thermal impedance, method 3131 of MIL-STD-750	Required Not applicable Thermal impedance, method 3131 of MIL-STD-750
4	Required	Optional	Optional
5	Required	Required	Not applicable
7a and 7b	Required	Required	Required
8	Required	Not required	Not required
9	I <sub>CBO2</sub> , h <sub>FE4</sub>	I <sub>CBO2</sub> , h <sub>FE4</sub>	Not applicable
10	48 hours minimum	48 hours minimum	48 hours minimum
11	I <sub>CBO2</sub> ; h <sub>FE4</sub> ; ΔI <sub>CBO2</sub> = 100 percent of initial value or 5 nA dc, whichever is greater. Δh <sub>FE4</sub> = ±15 percent	I <sub>CBO2</sub> ; h <sub>FE4</sub> ; ΔI <sub>CBO2</sub> = 100 percent of initial value or 5 nA dc, whichever is greater. Δh <sub>FE4</sub> = ±15 percent	I <sub>CBO2</sub> ; h <sub>FE4</sub>
12	See 4.3.2 240 hours minimum	See 4.3.2 240 hours minimum	See 4.3.2 80 hours minimum
13	Subgroups 2 and 3 of table I herein; ΔI <sub>CBO2</sub> = 100 percent of initial value or 5 nA dc, whichever is greater; Δh <sub>FE4</sub> = ±15 percent	Subgroups 2 and 3 of table I herein; ΔI <sub>CBO2</sub> = 100 percent of initial value or 5 nA dc, whichever is greater; Δh <sub>FE4</sub> = ±15 percent	Subgroup 2 of table I herein; ΔI <sub>CBO2</sub> = 100 percent of initial value or 5 nA dc, whichever is greater; Δh <sub>FE4</sub> = ±15 percent
14a and 14b	Optional	Optional	Optional
15	Required	Required	Not required
16	Required	Required	Not required

4.3.1 Screening (JANHC and JANKC). Screening of JANHC and JANKC die shall be in accordance with MIL-PRF-19500 "Discrete Semiconductor Die/Chip Lot Acceptance". Burn-in duration for the JANKC level follows JANS requirements; the JANHC follows JANTX requirements.

4.3.2 Power burn-in conditions. Power burn-in conditions are as follows:  $V_{CB} = 10\text{-}30$  V dc. Power shall be applied to achieve  $T_J = +135^\circ\text{C}$  minimum using a minimum  $P_D = 75$  percent of  $P_T$  maximum rated as defined in 1.3.

4.4 Conformance inspection. Conformance inspection shall be in accordance with MIL-PRF-19500, and as specified herein. If alternate screening is being performed in accordance with MIL-PRF-19500, a sample of screened devices shall be submitted to and pass the requirements of group A1 and A2 inspection only (table VIb, group B, subgroup 1 is not required to be performed again if group B has already been satisfied in accordance with 4.4.2).

4.4.1 Group A inspection. Group A inspection shall be conducted in accordance with MIL-PRF-19500, and table I herein.

4.4.2 Group B inspection. Group B inspection shall be conducted in accordance with the tests and conditions specified for subgroup testing in table VIa (JANS) of MIL-PRF-19500 and 4.4.2.1. Electrical measurements (end-points) and delta requirements shall be in accordance with group A, subgroup 2 and 4.5.3 herein: delta requirements only apply to subgroups B4, and B5. See 4.4.2.2 for JAN, JANJ, JANTX, and JANTXV group B testing. Electrical measurements (end-points) and delta requirements for JAN, JANJ, JANTX, and JANTXV shall be after each step in 4.4.2.2 and shall be in accordance with group A, subgroup 2 and 4.5.3 herein.

\* 4.4.2.1 Group B inspection, table VIa (JANS) of MIL-PRF-19500.

<u>Subgroup</u>	<u>Method</u>	<u>Condition</u>
B4	1037	$V_{CB} = 10$ V dc.
B5	1027	$V_{CB} = 10$ V dc; $P_D \geq 100$ percent of maximum rated $P_T$ (see 1.3). (NOTE: If a failure occurs, resubmission shall be at the test conditions of the original sample.)
		Option 1: 96 hours minimum sample size in accordance with MIL-PRF-19500, table VIa, adjust $T_A$ or $P_D$ to achieve $T_J = +275^\circ\text{C}$ minimum.
		Option 2: 216 hours minimum, sample size = 45, $c = 0$ ; adjusted $T_A$ or $P_D$ to achieve a $T_J = +225^\circ\text{C}$ minimum.

4.4.2.2 Group B inspection, (JAN, JANJ, JANTX, and JANTXV). Separate samples may be used for each step. In the event of a group B failure, the manufacturer may pull a new sample at double size from either the failed assembly lot or from another assembly lot from the same wafer lot. If the new "assembly lot" option is exercised, the failed assembly lot shall be scrapped.

<u>Step</u>	<u>Method</u>	<u>Condition</u>
1	1039	Steady-state life: Test condition B, 340 hours minimum, $V_{CB} = 10 - 30$ V dc, power shall be applied to achieve $T_J = +150^\circ\text{C}$ minimum using a minimum of $P_D = 75$ percent of maximum rated $P_T$ as defined in 1.3. $n = 45$ devices, $c = 0$ .
2	1039	The steady-state life test of step 1 shall be extended to 1,000 hrs for each die design. Samples shall be selected from a wafer lot every twelve months of wafer production. Group B step 2 shall not be required more than once for any single wafer lot. $n = 45$ , $c = 0$ .
3	1032	High-temperature life (non-operating), $t = 340$ hours, $T_A = +200^\circ\text{C}$ . $n = 22$ , $c = 0$ .

4.4.2.3 Group B sample selection. Samples selected from group B inspection shall meet all of the following requirements:

- a. For JAN, JANJ, JANTX, and JANTXV samples shall be selected randomly from a minimum of three wafers (or from each wafer in the lot) from each wafer lot. For JANS, samples shall be selected from each inspection lot. See MIL-PRF-19500.
- b. Must be chosen from an inspection lot that has been submitted to and passed group A, subgroup 2, conformance inspection. When the final lead finish is solder or any plating prone to oxidation at high temperature, the samples for life test (subgroups B4 and B5 for JANS, and group B for JAN, JANJ, JANTX, and JANTXV) may be pulled prior to the application of final lead finish.

4.4.3 Group C inspection. Group C inspection shall be conducted in accordance with the test and conditions specified for subgroup testing in table VII of MIL-PRF-19500, and in 4.4.3.1 (JANS) and 4.4.3.2 (JAN, JANJ, JANTX, and JANTXV) herein for group C testing. Electrical measurements (end-points) and delta requirements shall be in accordance with group A, subgroup 2 and 4.5.3 herein; delta requirements only apply to subgroup C6.

4.4.3.1 Group C inspection, table VII (JANS) of MIL-PRF-19500.

<u>Subgroup</u>	<u>Method</u>	<u>Condition</u>
C2	2036	Test condition E; (method 2036 not applicable for UA and UB devices).
C6	1026	1,000 hours at $V_{CB} = 10$ V dc; power shall be applied to achieve $T_J = +150^\circ\text{C}$ minimum and a minimum of $P_D = 75$ percent of maximum rated $P_T$ as defined in 1.3.

4.4.3.2 Group C inspection, table VII (JAN, JANJ, JANTX, and JANTXV) of MIL-PRF-19500.

<u>Subgroup</u>	<u>Method</u>	<u>Condition</u>
C2	2036	Test condition E; not applicable for UA and UB devices.
C5	3131	$R_{\theta JA}$ (see 1.3).
C6		Not applicable.

4.4.3.3 Group C sample selection. Samples for subgroups in group C shall be chosen at random from any inspection lot containing the intended package type and lead finish procured to the same specification which is submitted to and passes group A tests for conformance inspection. When the final lead finish is solder or any plating prone to oxidation at high temperature, the samples for C6 life test may be pulled prior to the application of final lead finish. Testing of a subgroup using a single device type enclosed in the intended package type shall be considered as complying with the requirements for that subgroup.

4.4.4 Group D inspection. Conformance inspection for hardness assured JANS and JANTXV types shall include the group D tests specified in table II herein. These tests shall be performed as required in accordance with MIL-PRF-19500 and method 1019 of MIL-STD-750, for total ionizing dose or method 1017 of MIL-STD-750 for neutron fluence as applicable.

\* 4.4.5 Group E inspection. Group E inspection shall be conducted in accordance with the conditions specified for subgroup testing in appendix E, table IX of MIL-PRF-19500 and as specified in table III herein. Electrical measurements (end-points) shall be in accordance with table I, subgroup 2 herein; except,  $Z_{\theta JX}$  need not be performed. Delta measurements shall be in accordance with the applicable steps of 4.5.3.

MIL-PRF-19500/255N

4.5 Method of inspection. Methods of inspection shall be as specified in the appropriate tables and as follows.

4.5.1 Pulse measurements. Conditions for pulse measurement shall be as specified in section 4 of MIL-STD-750.

4.5.2 Input capacitance. This test shall be conducted in accordance with method 3240 of MIL-STD-750, except the output capacitor shall be omitted.

4.5.3 Delta requirements. Delta requirements shall be as specified below:

Step	Inspection	MIL-STD-750		Symbol	Limit	Unit
		Method	Conditions			
1	Collector-base cutoff current	3036	Bias condition D, $V_{CB} = 60 \text{ V dc}$	$\Delta I_{CB02}$ (1)	100 percent of initial value or 8 nA dc, whichever is greater.	
2	Forward current transfer ratio	3076	$V_{CE} = 10 \text{ V dc};$ $I_C = 150 \text{ mA dc};$ pulsed see 4.5.1	$\Delta h_{FE4}$ (1)	$\pm 25$ percent change from initial reading.	

(1) Devices which exceed the group A limits for this test shall not be accepted.

MIL-PRF-19500/255N

TABLE I. Group A inspection.

Inspection <u>1/</u>	MIL-STD-750		Symbol	Limit		Unit
	Method	Conditions		Min	Max	
<u>Subgroup 1 2/</u>						
Visual and mechanical <u>3/</u> examination <u>3/</u>	2071	n = 45 devices, c = 0				
Solderability <u>3/ 4/</u>	2026	n = 15 leads, c = 0				
Resistance to solvents <u>3/ 4/ 5/</u>	1022	n = 15 devices, c = 0				
Temp cycling <u>3/ 4/</u>	1051	Test condition C, 25 cycles. n = 22 devices, c = 0				
Hermetic seal <u>4/</u> Fine leak Gross leak	1071	n = 22 devices, c = 0				
Electrical measurements <u>4/</u>		Group A, subgroup 2				
Bond strength <u>3/ 4/</u>	2037	Precondition T <sub>A</sub> = +250°C at t = 24 hrs or T <sub>A</sub> = +300°C at t = 2 hrs n = 11 wires, c = 0				
Decap internal visual (design verification) <u>4/</u>	2075	n = 4 devices, c = 0				
<u>Subgroup 2</u>						
Collector to base cutoff current	3036	V <sub>CB</sub> = 75 V dc	I <sub>CBO1</sub>		10	μA dc
Emitter to base cutoff current	3061	V <sub>EB</sub> = 6 V dc	I <sub>EBO1</sub>		10	μA dc
Breakdown voltage, collector to emitter	3011	Bias condition D; I <sub>C</sub> = 10 mA dc; pulsed (see 4.5.1)	V <sub>(BR)CEO</sub>	50		V dc
Collector to emitter cutoff current	3041	Bias condition C; V <sub>CE</sub> = 50 V dc	I <sub>CES</sub>		50	nA dc
Collector to base cutoff current	3036	Bias condition D; V <sub>CB</sub> = 60 V dc	I <sub>CBO2</sub>		10	nA dc
Emitter to base cutoff current	3061	Bias condition D; V <sub>EB</sub> = 4 V dc	I <sub>EBO2</sub>		10	nA dc
Forward-current transfer ratio 2N2221A, L, UA, UB 2N2222A, L, UA, UB	3076	V <sub>CE</sub> = 10 V dc; I <sub>C</sub> = 0.1 mA dc	h <sub>FE1</sub>	30 50		
Forward-current transfer ratio 2N2221A, L, UA, UB 2N2222A, L, UA, UB	3076	V <sub>CE</sub> = 10 V dc; I <sub>C</sub> = 1.0 mA dc	h <sub>FE2</sub>	35 75	150 325	
Forward-current transfer ratio 2N2221A, L, UA, UB 2N2222A, L, UA, UB	3076	V <sub>CE</sub> = 10 V dc; I <sub>C</sub> = 10 mA dc	h <sub>FE3</sub>	40 100		

See footnotes at end of table.

MIL-PRF-19500/255N

TABLE I. Group A inspection - Continued.

Inspection <u>1/</u>	MIL-STD-750		Symbol	Limit		Unit
	Method	Conditions		Min	Max	
<u>Subgroup 2</u> - Continued						
Forward-current transfer ratio 2N2221A, L, UA, UB 2N2222A, L, UA, UB	3076	$V_{CE} = 10 \text{ V dc}; I_C = 150 \text{ mA dc};$ pulsed (see 4.5.1)	$h_{FE4}$	40 100	120 300	
Forward-current transfer ratio 2N2221A, L, UA, UB 2N2222A, L, UA, UB	3076	$V_{CE} = 10 \text{ V dc}; I_C = 500 \text{ mA dc};$ pulsed (see 4.5.1)	$h_{FE5}$	20 30		
Collector-emitter saturation voltage	3071	$I_C = 150 \text{ mA dc}; I_B = 15 \text{ mA dc};$ pulsed (see 4.5.1)	$V_{CE(sat)1}$		0.3	V dc
Collector-emitter saturation voltage	3071	$I_C = 500 \text{ mA dc}; I_B = 50 \text{ mA dc};$ pulsed (see 4.5.1)	$V_{CE(sat)2}$		1.0	V dc
Base-emitter saturation voltage	3066	Test condition A; $I_C = 150 \text{ mA dc};$ $I_B = 15 \text{ mA dc};$ pulsed (see 4.5.1)	$V_{BE(sat)1}$	0.6	1.2	V dc
Base-emitter saturation voltage	3066	Test condition A; $I_C = 500 \text{ mA dc};$ $I_B = 50 \text{ mA dc};$ pulsed (see 4.5.1)	$V_{BE(sat)2}$		2.0	V dc
<u>Subgroup 3</u>						
High temperature operation		$T_A = +150^\circ\text{C}$				
Collector to base cutoff current	3036	Bias condition D; $V_{CB} = 60 \text{ V dc}$	$I_{CBO3}$		10	$\mu\text{A dc}$
Low temperature operation		$T_A = -55^\circ\text{C}$				
Forward-current transfer ratio 2N2221A, L, UA, UB 2N2222A, L, UA, UB	3076	$V_{CE} = 10 \text{ V dc}; I_C = 10 \text{ mA dc}$	$h_{FE6}$	15 35		
<u>Subgroup 4</u>						
Small-signal short-circuit forward current transfer ratio 2N2221A, L, UA, UB 2N2222A, L, UA, UB	3206	$V_{CE} = 10 \text{ V dc}; I_C = 1 \text{ mA dc};$ $f = 1 \text{ kHz}$	$h_{fe}$	30 50		
Magnitude of small-signal short-circuit forward current transfer ratio	3306	$V_{CE} = 20 \text{ V dc}; I_C = 20 \text{ mA dc};$ $f = 100 \text{ MHz}$	$ h_{fe} $	2.5		
Open circuit output capacitance	3236	$V_{CB} = 10 \text{ V dc}; I_E = 0;$ $100 \text{ kHz} \leq f \leq 1 \text{ MHz}$	$C_{obo}$		8	pF

See footnotes at end of table.



MIL-PRF-19500/255N

\* TABLE I. Group A inspection - Continued.

Inspection <u>1/</u>	MIL-STD-750		Symbol	Limit		Unit
	Method	Conditions		Min	Max	
<u>Subgroup 4</u> - Continued						
Input capacitance (output open-circuited)	3240	$V_{EB} = 0.5 \text{ V dc}; I_C = 0;$ $100 \text{ kHz} \leq f \leq 1 \text{ MHz}$	$C_{ibo}$		25	pF
Saturated turn-on time		(See figure 7)	$t_{on}$		35	ns
Saturated turn-off time		(See figure 8)	$t_{off}$		300	ns
<u>Subgroups 5 and 6</u>						
Not required						

1/ For sampling plan see MIL-PRF-19500.

2/ For resubmission of failed subgroup A1, double the sample size of the failed test or sequence of tests. A failure in group A, subgroup 1 shall not require retest of the entire subgroup. Only the failed test shall be rerun upon submission.

3/ Separate samples may be used.

4/ Not required for JANS devices.

5/ Not required for laser marked devices.

MIL-PRF-19500/255N

TABLE II. Group D inspection.

Inspection <u>1/ 2/</u>	MIL-STD-750		Symbol	Limit		Unit
	Method	Conditions		Min	Max	
<u>Subgroup 1</u>						
Neutron irradiation	1017					
Collector to base cutoff current	3036	Bias condition D; $V_{CB} = 60$ V dc	$I_{CBO1}$		20	nA dc
Forward-current transfer ratio	3076	$V_{CE} = 10$ V dc; $I_C = 0.1$ mA dc	$h_{FE1}$	35 34 10		
M2N2221A, D2N2222A, R2N2222A, H2N2222A						
Forward-current transfer ratio	3076	$V_{CE} = 10$ V dc; $I_C = 1.0$ mA dc	$h_{FE2}$	49 49 21	325	
M2N2221A, D2N2222A, R2N2222A, H2N2222A						
Forward-current transfer ratio	3076	$V_{CE} = 10$ V dc; $I_C = 10$ mA dc	$h_{FE3}$	89 89 49		
M2N2221A, D2N2222A, R2N2222A, H2N2222A						
Forward-current transfer ratio	3076	$V_{CE} = 10$ V dc; $I_C = 150$ mA dc	$h_{FE4}$	90 90 45	300	
M2N2221A, D2N2222A, R2N2222A, H2N2222A						
Forward-current transfer ratio	3076	$V_{CE} = 10$ V dc; $I_C = 500$ mA dc	$h_{FE5}$	27		
Collector-emitter saturation voltage	3071	$I_C = 150$ mA dc; $I_B = 15$ mA dc;	$V_{CE(sat)1}$		33	V dc
Collector-emitter saturation voltage	3071	$I_C = 500$ mA dc; $I_B = 50$ mA dc;	$V_{CE(sat)2}$		1.1	V dc
<u>Subgroup 2</u>						
Total dose irradiation	1019					
Collector to base cutoff current	3036	Bias condition D; $V_{CB} = 60$ V dc	$I_{CBO1}$		20	nA dc
Forward-current transfer ratio	3076	$V_{CE} = 10$ V dc; $I_C = 0.1$ mA dc	$h_{FE1}$	45 34 10		
M2N2221A, D2N2222A, R2N2222A, H2N2222A						
Forward-current transfer ratio	3076	$V_{CE} = 10$ V dc; $I_C = 1.0$ mA dc	$h_{FE2}$	67 60 21	325	
M2N2221A, D2N2222A, R2N2222A, H2N2222A						

See footnotes at end of table.

TABLE II. Group D inspection - Continued.

Inspection <u>1/</u> <u>2/</u>	MIL-STD-750		Symbol	Limit		Unit
	Method	Conditions		Min	Max	
<u>Subgroup 2</u> - Continued						
Forward-current transfer ratio M2N2221A, D2N2222A, R2N2222A, H2N2222A	3076	$V_{CE} = 10 \text{ V dc}; I_C = 10 \text{ mA dc}$	$h_{FE3}$	90 90 50		
Forward-current transfer ratio M2N2221A, D2N2222A, R2N2222A, H2N2222A	3076	$V_{CE} = 10 \text{ V dc}; I_C = 150 \text{ mA dc}$	$h_{FE4}$	90 90 45		
Forward-current transfer ratio	3076	$V_{CE} = 10 \text{ V dc}; I_C = 500 \text{ mA dc};$	$h_{FE5}$	27		
Collector-emitter saturation voltage	3071	$I_C = 150 \text{ mA dc}; I_B = 15 \text{ mA dc};$	$V_{CE(sat)1}$		.33	V dc
Collector-emitter saturation voltage	3071	$I_C = 500 \text{ mA dc}; I_B = 50 \text{ mA dc};$	$V_{CE(sat)2}$		1.1	V dc

1/ Tests to be performed on all devices.

2/ For sampling plan, see MIL-PRF-19500.

MIL-PRF-19500/255N

\* TABLE III. Group E inspection (all quality levels) - for qualification only.

Inspection	MIL-STD-750		Qualification
	Method	Conditions	
<u>Subgroup 1</u>			45 devices c = 0
Temperature cycling (air to air)	1051	Test condition C, 500 cycles	
Hermetic seal	1071		
Fine leak			
Gross leak			
Electrical measurements		See group A, subgroup 2 and 4.5.3 herein.	
<u>Subgroup 2</u>			45 devices c = 0
Intermittent life	1037	Intermittent operation life: $V_{CB} = 10$ V dc, 6000 cycles	
Electrical measurements		See group A, subgroup 2 and 4.5.3 herein.	
<u>Subgroups 3, 4, 5, 6, and 7</u>			
Not applicable			
<u>Subgroup 8</u>			45 devices c = 0
Reverse stability	1033	Condition A for devices $\geq 400$ V, condition B for devices $< 400$ V.	

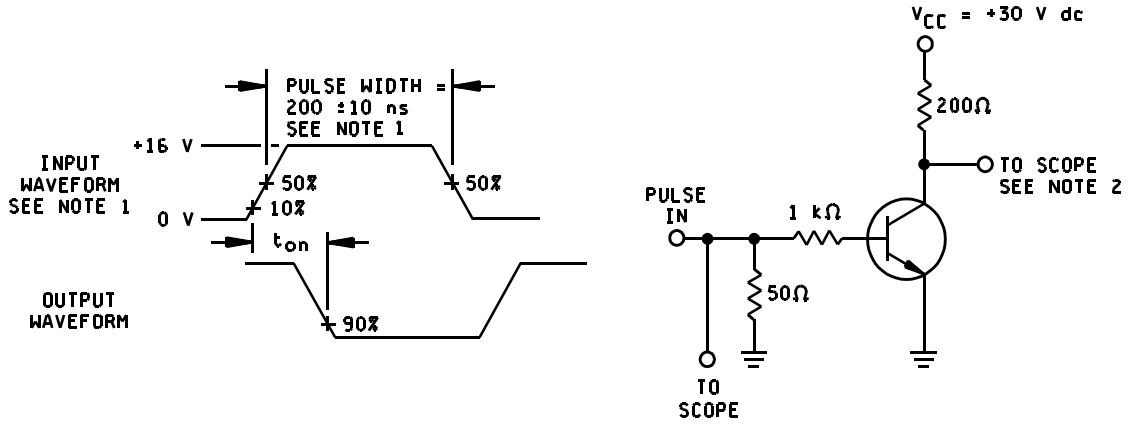

NOTES:

1. The rise time ( $t_r$ ) of the applied pulse shall be  $\leq 2.0$  ns, duty cycle  $\leq 2$  percent, and the generator source impedance shall be  $50 \Omega$ .
2. Sampling oscilloscope:  $Z_{IN} \geq 100$  kΩ,  $C_{IN} \leq 12$  pF, rise time  $\leq 5$  ns.

\* FIGURE 7. Saturated turn-on switching time test circuit.

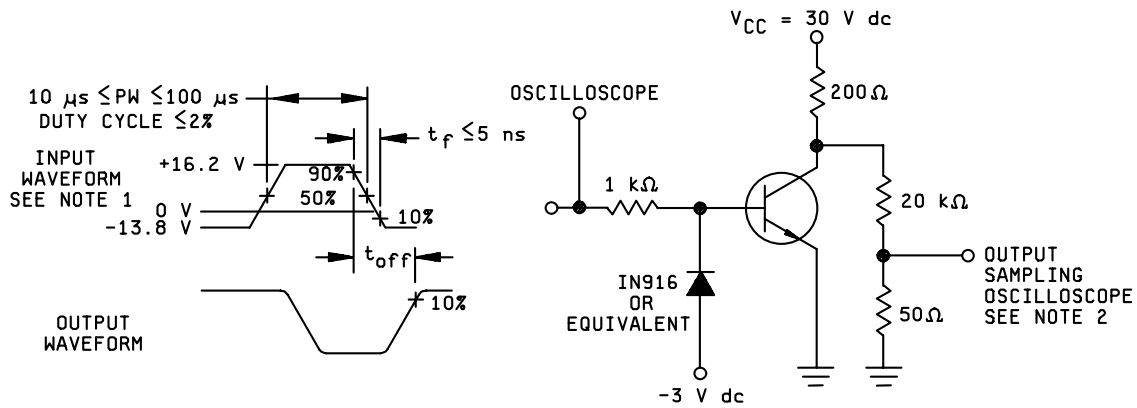

NOTES:

1. The rise time ( $t_r$ ) of the applied pulse shall be  $\leq 2.0$  ns, duty cycle  $\leq 2$  percent, and the generator source impedance shall be  $50 \Omega$ .
2. Sampling oscilloscope:  $Z_{IN} \geq 100$  kΩ,  $C_{IN} \leq 12$  pF, rise time  $\leq 5$  ns.

\* FIGURE 8. Saturated turn-off switching time test circuit.

## 5. PACKAGING

5.1 Packaging. For acquisition purposes, the packaging requirements shall be as specified in the contract or order (see 6.2). When actual packaging of materiel is to be performed by DoD personnel, these personnel need to contact the responsible packaging activity to ascertain requisite packaging requirements. Packaging requirements are maintained by the Inventory Control Points' packaging activity within the Military Department or Defense Agency, or within the Military Departments' System Command. Packaging data retrieval is available from the managing Military Departments' or Defense Agency's automated packaging files, CD-ROM products, or by contacting the responsible packaging activity.

## 6. NOTES

(This section contains information of a general or explanatory nature that may be helpful, but is not mandatory.)

6.1 Intended use. The notes specified in MIL-PRF-19500 are applicable to this specification.

6.2 Acquisition requirements. Acquisition documents must specify the following:

- a. Title, number, and date of this specification.
- b. Issue of DoDISS to be cited in the solicitation, and if required, the specific issue of individual documents referenced (see 2.2).
- c. Packaging requirements (see 5.1).
- d. Lead formation and finish may be specified (see 3.4.1).
- e. Type designation and product assurance level.
- \* f. For die acquisition, the JANHC or JANKC letter version shall be specified (see figures 4 through 6) as well as the RHA designer, if applicable. The JANHCA/JANKCA die version is obsolete as of the date of this revision. Other letter versions should be used.
- g. Surface mount designation if applicable.

6.3 Qualification. With respect to products requiring qualification, awards will be made only for products which are, at the time of award of contract, qualified for inclusion in Qualified Manufacturers' List (QML) whether or not such products have actually been so listed by that date. The attention of the contractors is called to these requirements, and manufacturers are urged to arrange to have the products that they propose to offer to the Federal Government tested for qualification in order that they may be eligible to be awarded contracts or orders for the products covered by this specification. Information pertaining to qualification of products may be obtained from Defense Supply Center, Columbus, ATTN: DSCC/VQE, P.O. Box 3990, Columbus, OH 43216-5000.

6.4 Supersession information. Devices covered by this specification supersede the manufacturers' and users' Part or Identifying Number (PIN). The term PIN is equivalent to the term part number which was previously used in this specification. This information in no way implies that manufacturers' PIN's are suitable as a substitute for the military PIN.

\* 6.5 Suppliers of JANHC and JANKC die. The qualified JANHC and JANKC suppliers with the applicable letter version (example JANHCB2N2221A) will be identified on the QML. The JANHCA/JANKCA die version is obsolete as of the date of this revision.

Die ordering information (1)			
PIN	Manufacturer		
	43611	34156	12969
2N2221A 2N2222A	JANHCB2N2221A JANHCB2N2222A	JANHCC2N2221A JANHCC2N2222A	JANHCD2N2221A JANHCD2N2222A

(1) For JANKC level, replace JANHC with JANKC.

\* 6.6 Changes from previous issue. The margins of this specification are marked with asterisks to indicate where changes from the previous issue were made. This was done as a convenience only and the Government assumes no liability whatsoever for any inaccuracies in these notations. Bidders and contractors are cautioned to evaluate the requirements of this document based on the entire content irrespective of the marginal notations and relationship to the last previous issue.

Custodians:  
 Army - CR  
 Navy - EC  
 Air Force - 11  
 NASA - NA  
 DLA - CC

Preparing activity:  
 DLA - CC  
 (Project 5961-2564)

Review activities:  
 Army - AR, MI, SM  
 Navy - AS, MC  
 Air Force - 19, 71, 99

**STANDARDIZATION DOCUMENT IMPROVEMENT PROPOSAL**

**INSTRUCTIONS**

1. The preparing activity must complete blocks 1, 2, 3, and 8. In block 1, both the document number and revision letter should be given.
2. The submitter of this form must complete blocks 4, 5, 6, and 7.
3. The preparing activity must provide a reply within 30 days from receipt of the form.

NOTE: This form may not be used to request copies of documents, nor to request waivers, or clarification of requirements on current contracts. Comments submitted on this form do not constitute or imply authorization to waive any portion of the referenced document(s) or to amend contractual requirements.

<b>I RECOMMEND A CHANGE:</b>	1. DOCUMENT NUMBER	2. DOCUMENT DATE
	MIL-PRF-19500/255N	15 February 2002

3. **DOCUMENT TITLE** SEMICONDUCTOR DEVICE, TRANSISTOR, NPN, SILICON, SWITCHING, TYPES 2N2221A, 2N2221AL, 2N2222A, 2N2222AL, 2N2221AUA 2N2222AUA, 2N2221AUB, AND 2N2222AUB, JAN, JANJ, JANTX, JANTXV, JANTXVD, JANTXVH, JANTXVM, JANTXVR, JANS, JANSJ, JANSK, JANSR, JANSH, JANSM, JANSR, JANHC, JANHCM, JANHCD, JANHCR, JANHCH, JANKC, JANKCM, JANKCD, JANKCR, AND JANKCH

4. NATURE OF CHANGE (Identify paragraph number and include proposed rewrite, if possible. Attach extra sheets as needed.)

5. REASON FOR RECOMMENDATION

6. SUBMITTER

a. NAME (Last, First, Middle initial)	b. ORGANIZATION	
c. ADDRESS (Include Zip Code)	d. TELEPHONE (Include Area Code)	7. DATE SUBMITTED
	COMMERCIAL DSN FAX EMAIL	

8. PREPARING ACTIVITY

a. Point of Contact Alan Barone	b. TELEPHONE Commercial      DSN      FAX      EMAIL 614-692-0510      850-0510      614-692-6939 <a href="mailto:alan.barone@dsc.dla.mil">alan.barone@dsc.dla.mil</a>
c. ADDRESS Defense Supply Center Columbus ATTN: DSCC-VAC P.O. Box 3990 Columbus, OH 43216-5000	IF YOU DO NOT RECEIVE A REPLY WITHIN 45 DAYS, CONTACT: Defense Standardization Program Office (DLSC-LM) 8725 John J. Kingman, Suite 2533 Fort Belvoir, VA 22060-6221 Telephone (703) 767-6888      DSN 427-6888