



A Unit of Teledyne Electronics and Communications

**SERIES  
712**

**COMMERCIAL  
TO-5 RELAYS  
DPDT**

SERIES DESIGNATION	RELAY TYPE
712	DPDT basic relay
712D	DPDT relay with internal diode for coil transient suppression
712TN	DPDT relay with internal transistor driver and coil transient suppression diode

**INTERNAL CONSTRUCTION**

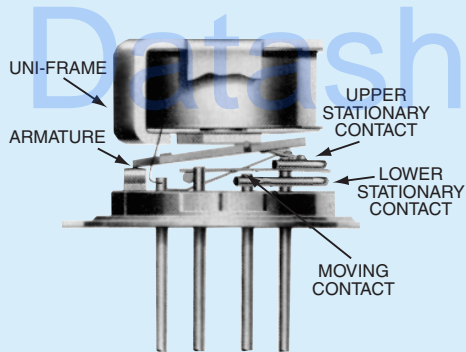

**DESCRIPTION**

The TO-5 relay, originally conceived and developed by Teledyne, has become one of the industry standards for low-level switching from dry circuit to 1 ampere. Designed for high-density PC board mounting, the Series 712 relays are some of the most versatile ultraminiature relays available because of their small size and low coil power dissipation.

The following unique construction features and manufacturing techniques provide excellent resistance to environmental extremes and overall high reliability:

- All welded construction.
- Unique uni-frame design providing high magnetic efficiency and mechanical rigidity.
- High force/mass ratios for resistance to shock and vibration.
- Advanced cleaning techniques provide maximum assurance of internal cleanliness.
- Precious metal alloy contact material with gold plating assures excellent high current and dry circuit switching capabilities.

The Series 712D relay has an internal discrete silicon diode for coil transient suppression. The hybrid Series 712TN relay has an internal silicon diode and transistor driver. The integrated packaging of the relay with its associated semiconductor devices greatly reduces PC board floor space requirements as well as component installation costs.

By virtue of its inherently low intercontact capacitance and contact circuit losses, the 712 has proven to be excellent ultraminiature RF switch for frequency ranges well into the UHF spectrum. A typical RF application for the TO-5 relay is in handheld radio transceivers, wherein the combined features of good RF performance, small size, low coil power dissipation and high reliability make it a preferred method of Transmit-Receive switching (see Figure 1).

**ENVIRONMENTAL AND PHYSICAL SPECIFICATIONS**

<b>Temperature</b> (Ambient)	<b>Storage</b>	-65°C to +125°C
	<b>Operating</b>	-55°C to +85°C
<b>Vibration</b> (General Note 1)		10 g's to 500 Hz
<b>Shock</b> (General Note 1)		30 g's, 6 msec, half-sine
<b>Enclosure</b>		Hermetically sealed
<b>Weight</b>		0.09 oz. (2.6g) max.

**SERIES 712**  
**GENERAL ELECTRICAL SPECIFICATIONS (@25°C) (Notes 2 & 3)**

<b>Contact Arrangement</b>	2 Form C (DPDT)	
<b>Rated Duty</b>	Continuous	
<b>Contact Resistance</b>	0.15 ohm max. before life; 0.25 ohm max. after life at 1A/28Vdc (measured 1/8" from header)	
<b>Contact Load Ratings (DC)</b> (See Fig. 2 for other DC resistive voltage/current ratings)	Resistive: 1 Amp/28Vdc Inductive: 200 mA/28Vdc (320 mH) Lamp: 100 mA/28Vdc Low Level: 10 to 50 $\mu$ A/10 to 50mV	
<b>Contact Load Ratings (AC)</b>	Resistive: 250 mA/115Vac, 60 and 400 Hz (Case not grounded) 100 mA/115Vac, 60 and 400 Hz (Case grounded)	
<b>Contact Life Ratings</b>	10,000,000 cycles (typical) at low level 1,000,000 cycles (typical) at 0.5A/28Vdc resistive 100,000 cycles min. at all other loads specified above	
<b>Contact Overload Rating</b>	2A/28Vdc Resistive (100 cycles min.)	
<b>Contact Carry Rating</b>	Contact factory	
<b>Coil Operating Power</b>	450 milliwatts typical at nominal rated voltage	
<b>Operate Time</b>	4.0 msec max. at nominal rated coil voltage	
<b>Release Time</b>	712: 3.0 msec max. 712D, 712TN: 6.0 msec max.	
<b>Intercontact Capacitance</b>	0.4 pf typical	
<b>Insulation Resistance</b>	1,000 megohms min. between mutually isolated terminals	
<b>Dielectric Strength</b>	Atmospheric pressure: 350 Vrms/60Hz	
<b>Negative Coil Transient (Vdc)</b>	712D, 712TN	2.0 max
<b>Diode P.I.V. (Vdc)</b>	712D, 712TN	60 min.
<b>712TN Transistor Characteristics</b>	<b>Base Voltage to Turn Off (Vdc)</b>	0.3 min
	<b>Emitter-base breakdown Voltage (BV<sub>EB0</sub>) (Vdc)</b>	6.0 min
	<b>Collector-base breakdown Voltage (BV<sub>CB0</sub>) (@25°C &amp; I<sub>c</sub> = 100 <math>\mu</math>A) (Vdc)</b>	60 min

**DETAILED ELECTRICAL SPECIFICATIONS (@25°C) (Note 3)**

	BASE PART NUMBERS (See Note 7 for full P/N example)	➔					
		712-5 712D-5 712TN-5	712-6 712D-6 712TN-6	712-9 712D-9 712TN-9	712-12 712D-12 712TN-12	712-18 712D-18 712TN-18	712-26 712D-26 712TN-26
<b>Coil Voltage (Vdc)</b>	Nom.	5.0	6.0	9.0	12.0	18.0	26.5
	Max.	5.8	8.0	12.0	16.0	24.0	32.0
<b>Coil Resistance (Ohms <math>\pm</math>20% @25°C) (712TN: See Note 4)</b>		50	98	220	390	880	1560
<b>Pick-up Voltage (Vdc, Max.) Pulse Operated</b>		3.6	4.2	6.5	8.4	13.0	17.0
<b>Base Current to Turn On (mA<sub>dc</sub>, Min.) (See Note 5)</b>		3.00	2.04	1.36	1.03	0.68	0.50

**PERFORMANCE CURVES (Note 2)**

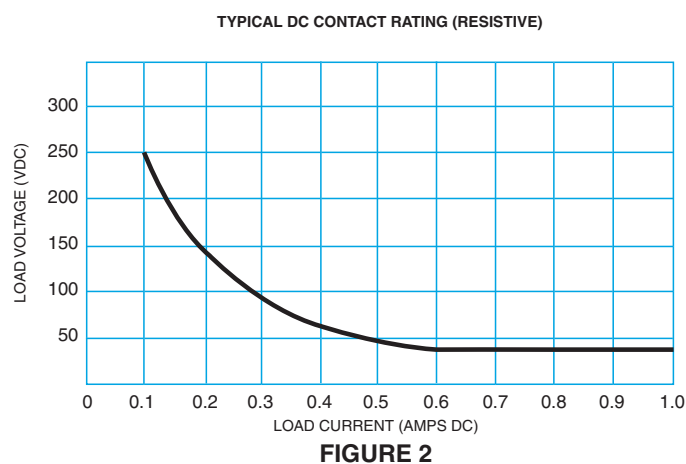
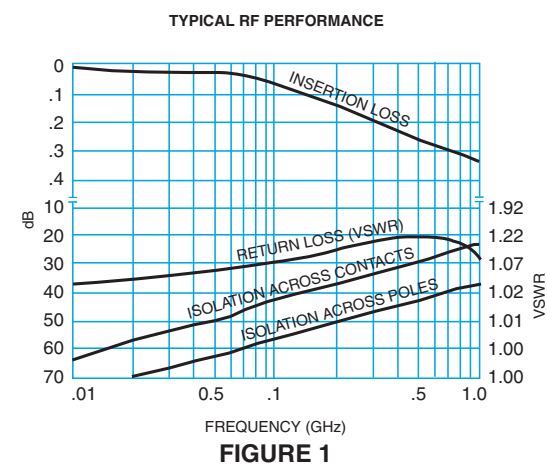

CENTIGRID® AND T0-5

**SERIES 712**

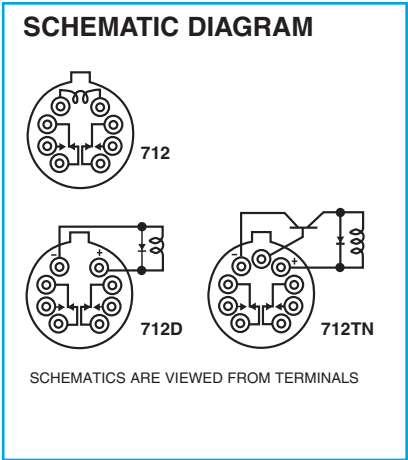
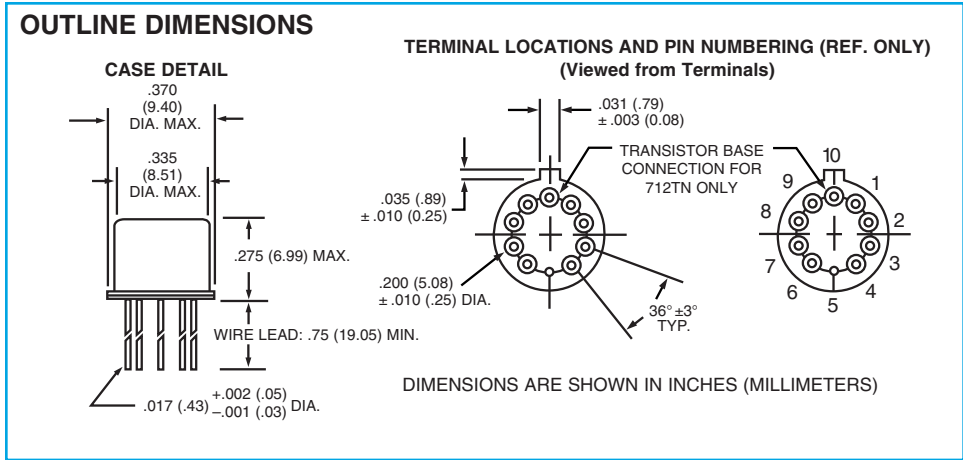

**GENERAL NOTES**

- Relay contacts will exhibit no chatter in excess of 10 µsec or transfer in excess of 1 µsec.
- “Typical” characteristics are based on available data and are best estimates. No on-going verification tests are performed.
- Unless otherwise specified, parameters are initial values.
- For Reference Only. Coil resistance not directly measurable on 712TN relays.
- Applicable to all coil voltages. See Base current to turn on.
- Circuit is typical for all Series 712TN. Values shown are for 712TN-5 relay and apply for full temperature range.
- The slash and characters appearing after the slash are not marked on the relay.
- Unless otherwise specified, relays will be supplied with either gold-plated or solder-coated leads.
- 

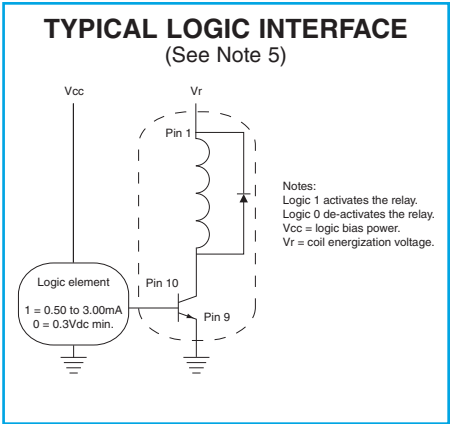

Teledyne Part Numbering System for Commercial Relays

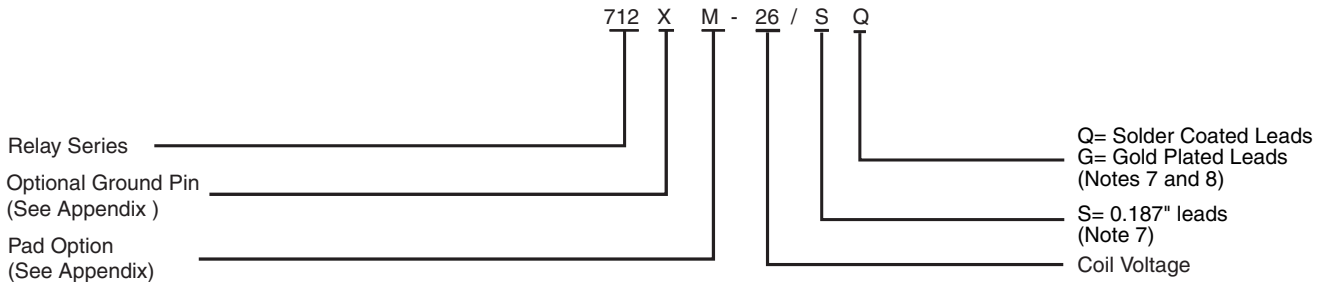

# Spacer Pads

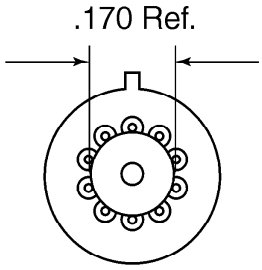
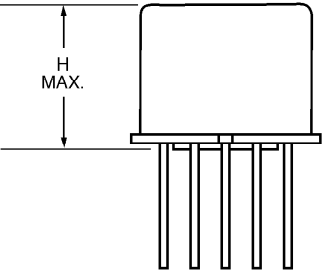
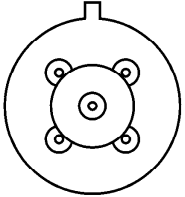
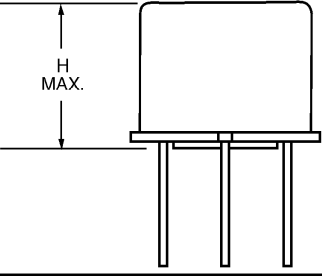
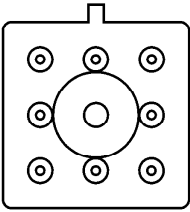
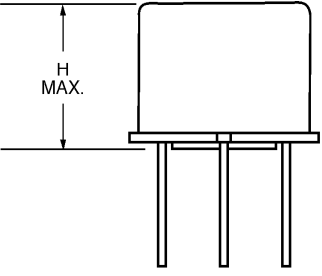
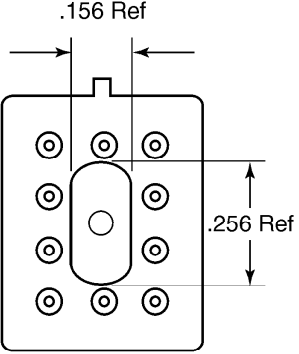
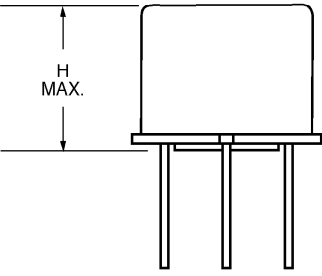
Pad designation and bottom view dimensions	Height	For use with the following relays	Dim. H Max
 <p>“M4” Pad for TO-5</p>		ER411T ER412, ER412D, ER412DD ER412T	.295 (7.49)
		712, 712D, 712TN	.300 (7.62)
		ER420, ER420D, ER420DD, ER421, ER421D, ER421DD, ER422, ER422D ER422DD, 722, 722D	.305 (7.75)
		ER431T ER432, ER432D, ER432DD ER432T	.400 (10.16)
		732, 732D, 732TN	.410 (10.41)
 <p>“M4” Pad for TO-5</p>		ER411, ER411D, ER411DD	.295 (7.49)
		ER431, ER431D, ER431DD	.400 (10.16)
 <p>“M4” Pad for Centigrad®</p>		172, 172D	/28 low profile .305 (7.75) high profile .405 (10.29)
		ER114, ER114D, ER114DD J114, J114D, J114DD	.300 (7.62)
		ER134, ER134D, ER134DD J134, J134D, J134DD	.400 (10.16)
 <p>“M9” Pad for Centigrad®</p>		122C	.320 (8.13)
		ER116C, J116C	.300 (7.62)
		ER1363C, J136C	.400 (10.16)

**NOTES:**

1. Spacer pad material: Polyester film.
2. To specify an “M4” or “M9” spacer pad, refer to the mounting variants portion of the part number example in the applicable data sheet.
3. Dimensions are in inches (mm).
4. Unless otherwise specified, tolerance is .010 (.25).
5. Add 10mΩ to the contact resistance shown in the data sheet.
6. Add .01 oz. (.25g) to the weight of the relay assembly shown in the data sheet.

# Spreader Pads

Spreader pads are provided as a lead configuration option

Pad designation and bottom view dimensions	Height and lead length	Use with the following relays	Dim. H Max.
<p><b>"M" Pad 5/6/</b></p>		ER411T, J411T, ER412, ER412D, ER412DD, J412, J412D, J412DD, ER412T, J412T	.388 (9.86)
		712, 712D, 712TN	.393 (9.99)
		ER431T, J431T, ER432, ER432D, ER432DD, J432, J432D, J432DD, ER4342T, J432T	.493 (12.52)
		732, 732D, 732TN	.503 (12.78)
<p><b>"M2" Pad 7/8/</b></p>		ER411T, ER412, ER412D, ER412DD, J412, J412D, J412DD	.441 (11.20)
		712, 712D	.451 (11.46)
		ER421, ER421D, ER421DD, 722, 722DD	.451 (11.46)
		ER431T, ER432, ER432D, ER432DD	.546 (13.87)
<p><b>"M3" Pad 5/6/9/</b></p>		ER411, ER411D, ER411DD, ER411TX, ER412X, ER412DX, ER412DDX, ER412TX	.388 (9.86)
		712X, 712DX, 712TNX	.393 (9.99)
		ER420X, ER420DX, ER420DDX, ER421X, ER421DX, ER421DDX, ER422X, ER422DX, ER422DDX, 722X, 722DDX	.398 (10.11)
		ER431, ER431D, ER431DD, ER431TX, ER432X, ER432DX, ER432DDX, ER432TX	.493 (12.52)
		732X, 732DX, 732TNX	.503 (12.78)

**NOTES:**

1. Spreader pad material: Diallyl Phthalate.
2. To specify an "M," "M2" or "M3" spreader pad, refer to the mounting variants portion of the part number example in the applicable data sheet.
3. Dimensions are in inches (mm).
4. Unless otherwise specified, tolerance is .010 (.25)
5. Add 25mΩ to the contact resistance shown in the data sheet.
6. Add .01 oz. (.25g) to the weight of the relay assembly shown in the data sheet.
7. Add 50mΩ to the contact resistance shown in the data sheet.
8. Add .025 oz. (.71g) to the weight of the relay assembly shown in the data sheet.
9. M3 pad to be used only when the relay has a center pin (e.g. ER411M3-12A, 722XM3-26).

# Ground Pin Positions

## Centigrad® Relays: RF100, RF103, ER114, ER134, 172

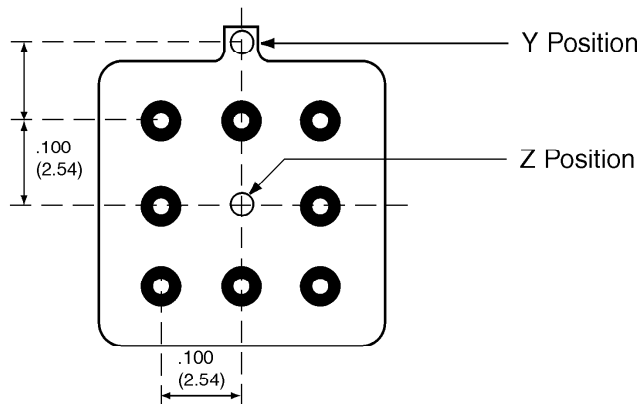

## Centigrad® Relays: RF180, ER116C, 122C, ER136C

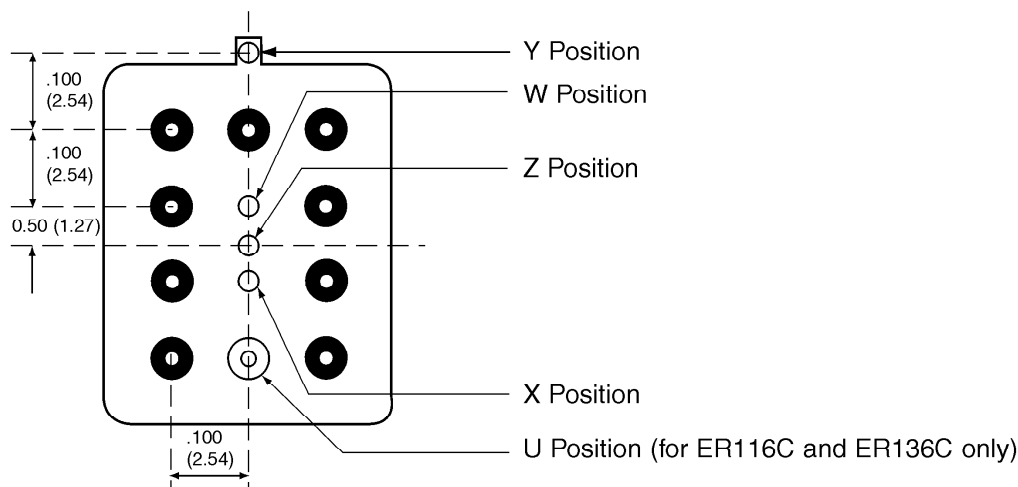

## TO-5 Relays: ER411T, ER412, ER412T, ER420, ER421, ER422, ER431T, ER432, ER432T, 712, 712TN, 400H, 400K, 400V, RF300, RF303, RF341

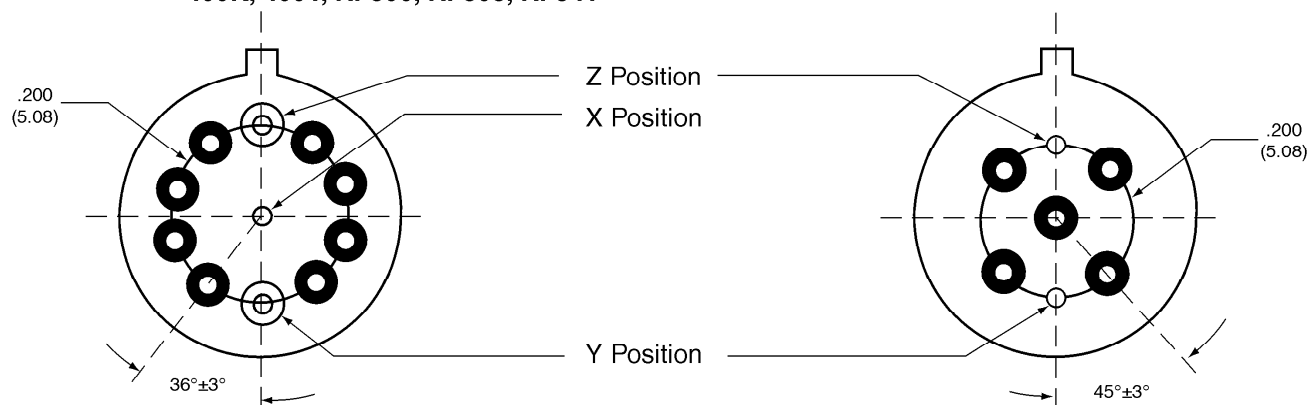

- Indicates ground pin position
- Indicates glass insulated lead position
- ⊙ Indicates ground pin or lead position depending on relay type

### NOTES

1. Terminal views shown.
2. Dimensions are in inches (millimeters)
3. Tolerances:  $\pm 0.010$  ( $\pm 0.25$ ) unless otherwise specified
4. Ground pin positions are within 0.015 (0.38) dia. of true position
5. Ground pin head dia., 0.035 (0.89) ref; height 0.010 (0.25) ref.
6. Lead dia. 0.017 (0.43) nom.