



**PRIMARE**



**CDI 10 CD Receiver  
Service Manual**

1. Schematics and Pcb.
2. Technical Specifications.

**Confidential !**

This document is not allowed to show for third part without written permission from Primare Systems AB.

This document is subject to change without notice.

**Author:**

Bjorn Holmqvist  
Primare AB

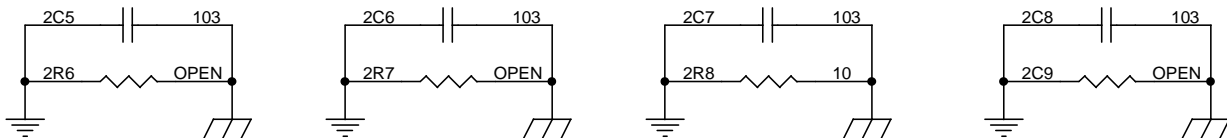
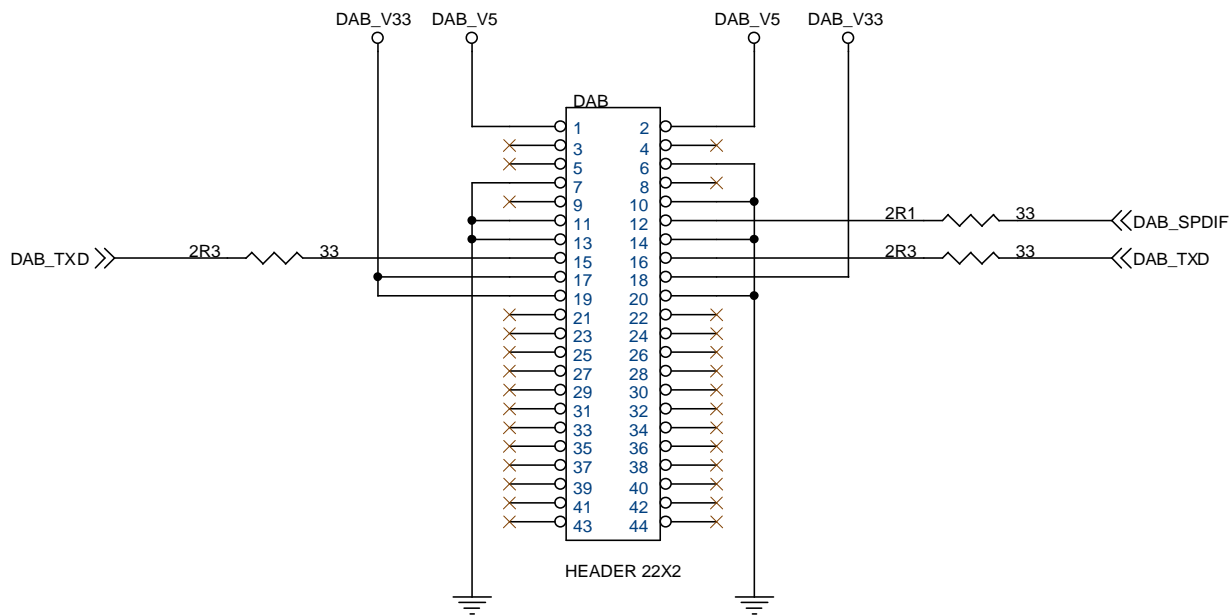
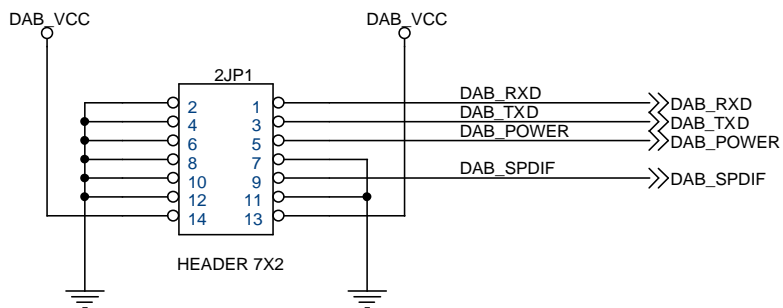
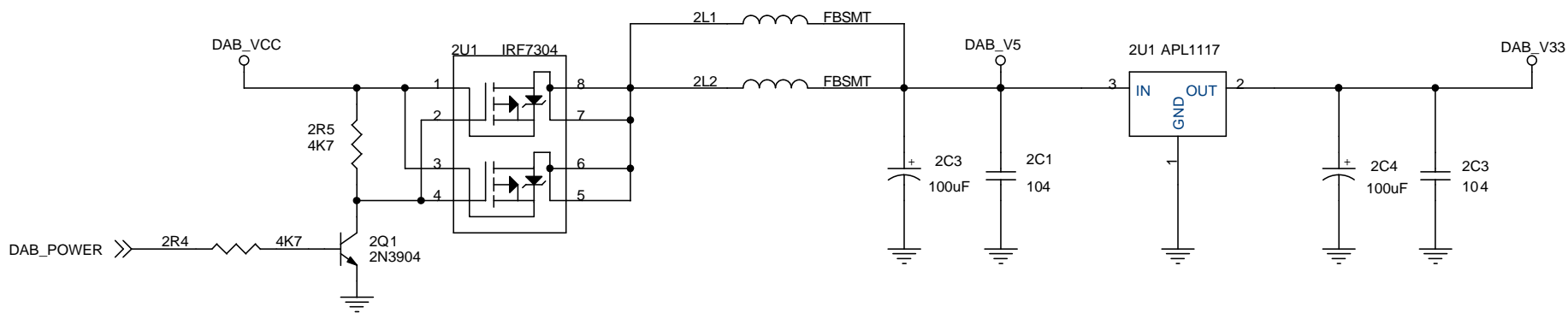

文件编号:	
拟制:	审核:
主机型号: CDI10	硬件版本: 2005-08
文件名称: DAB板原理图	
日期:	页次: 1/1

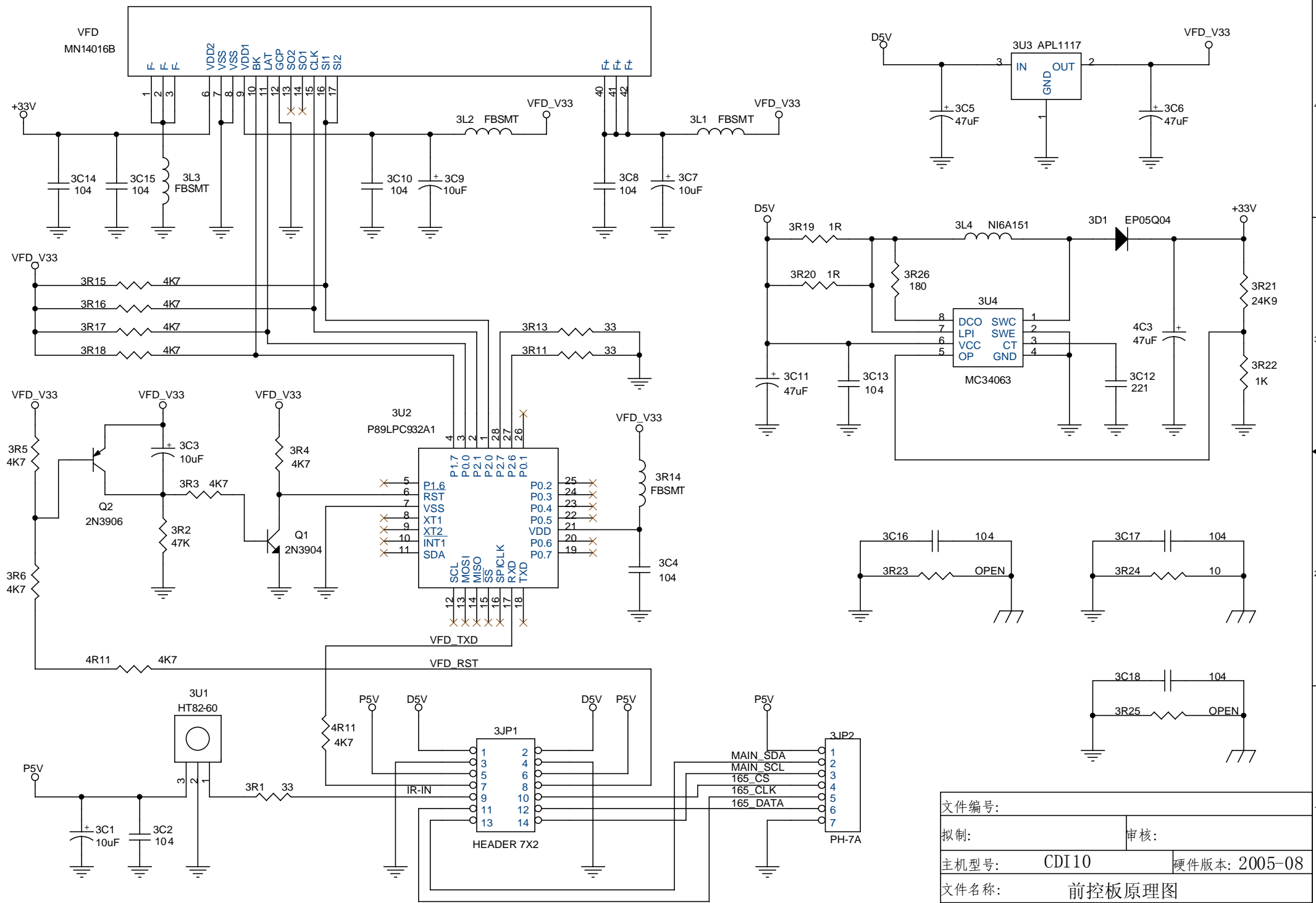

文件编号:	
拟制:	审核:
主机型号: CDI10	硬件版本: 2005-08
文件名称: 前控板原理图	
日期:	页次: 1/1

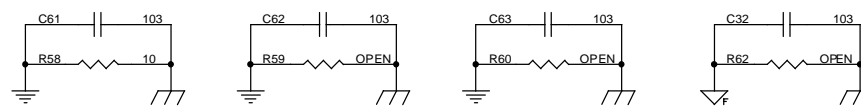
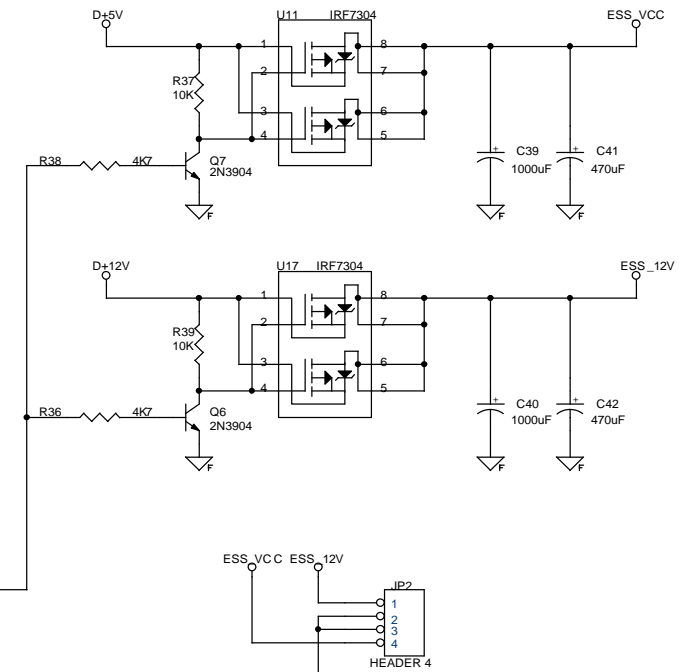
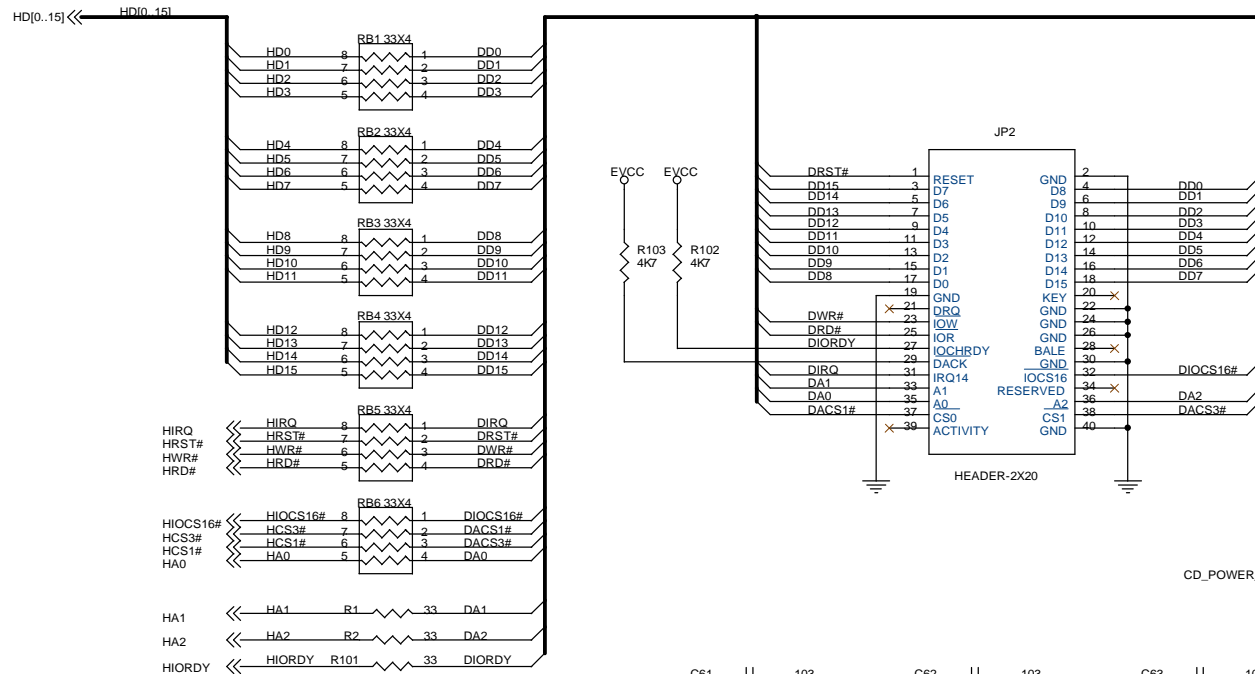
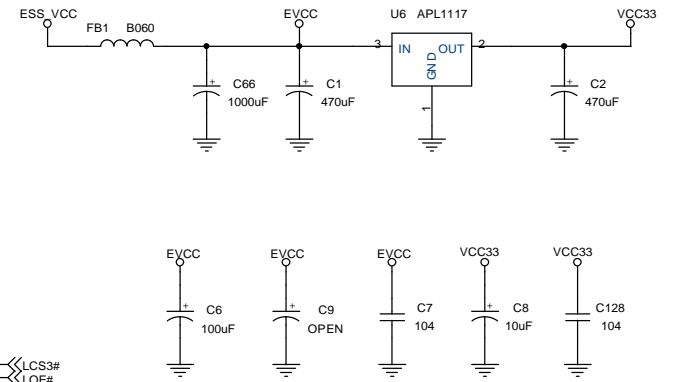
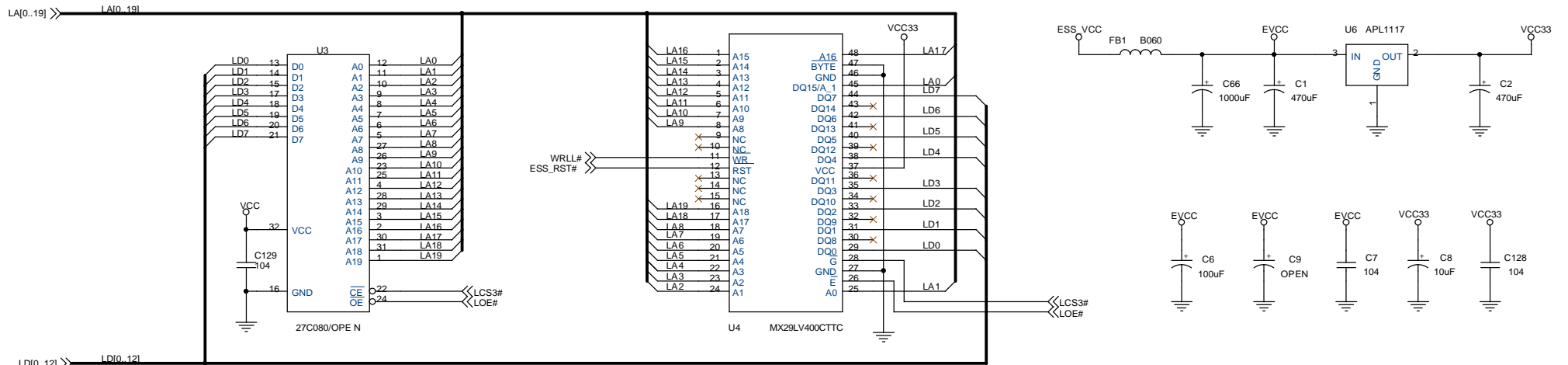

文件编号:	
拟制:	审核:
主机型号: CDI10	硬件版本: 2005-08
文件名称: 主板原理图	
日期:	页次: 2/7

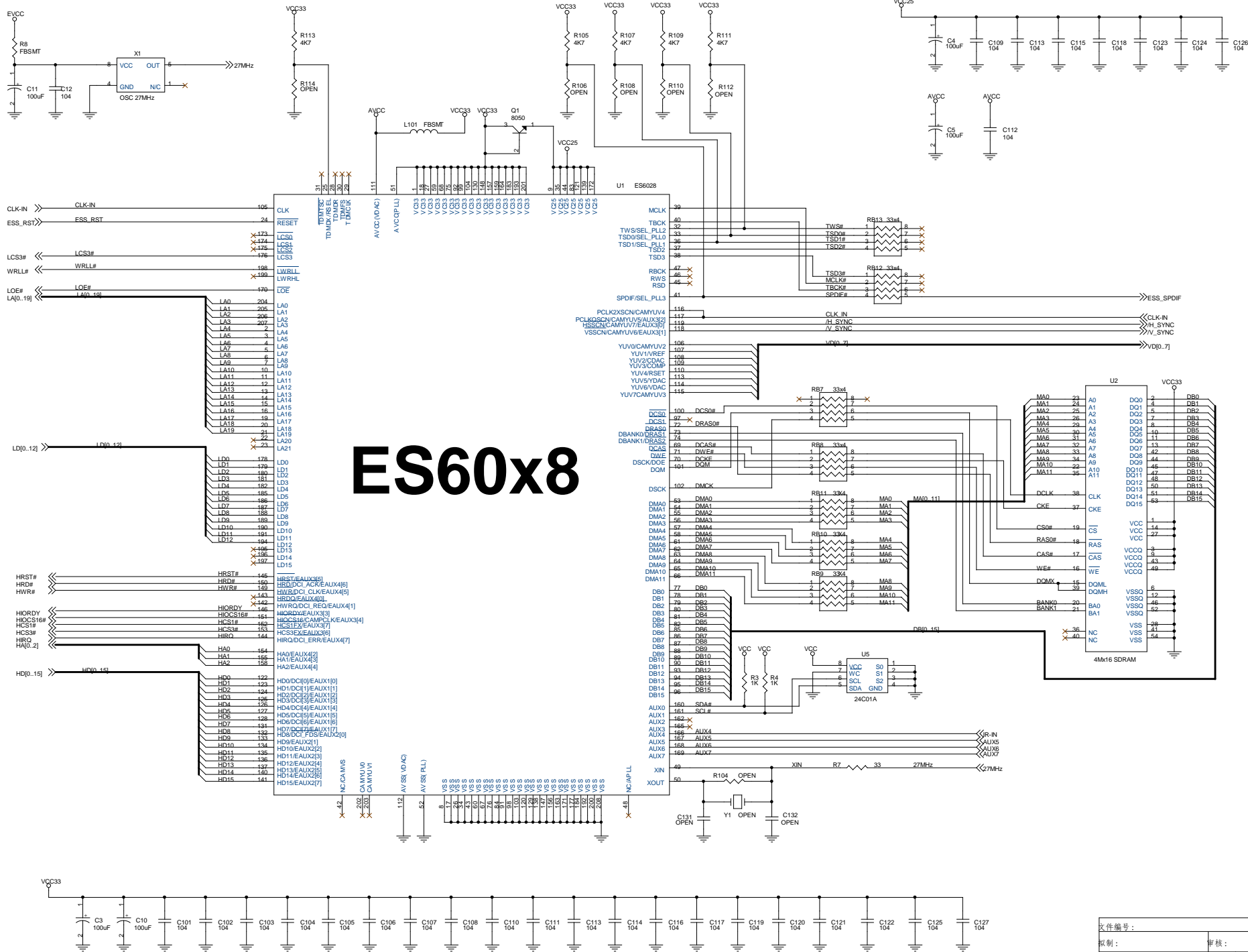

# ES60x8

文件编号:	
编制:	审核:
主机型号: CD110	硬件版本: 2005-08
文件名称: 主板原理图	
日期:	页次: 1/7

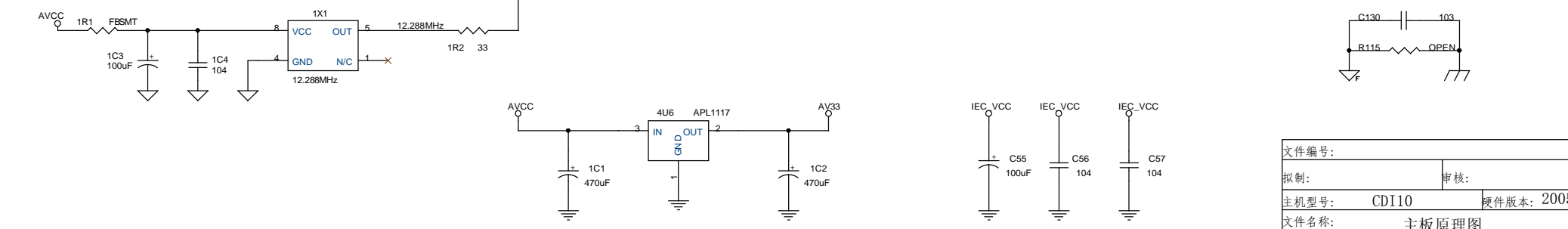
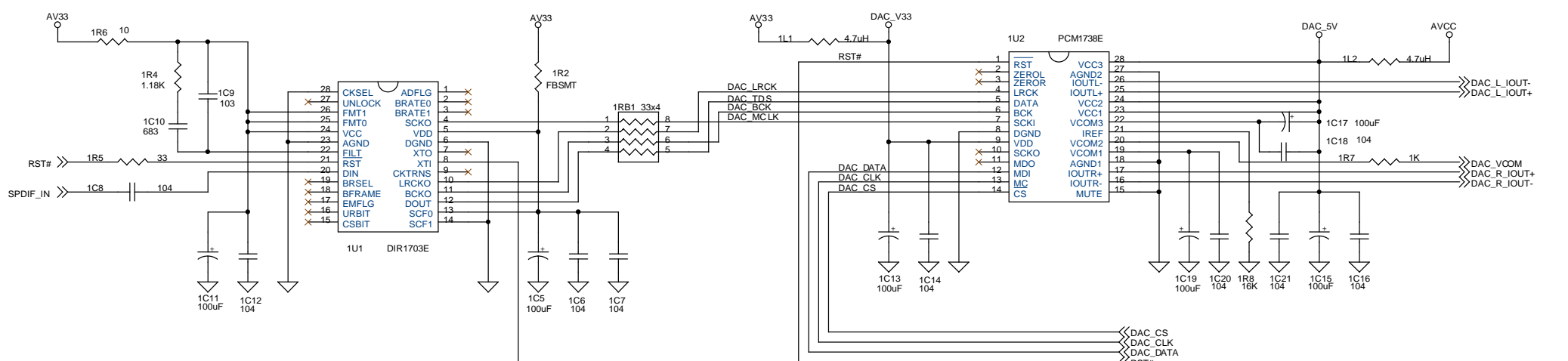
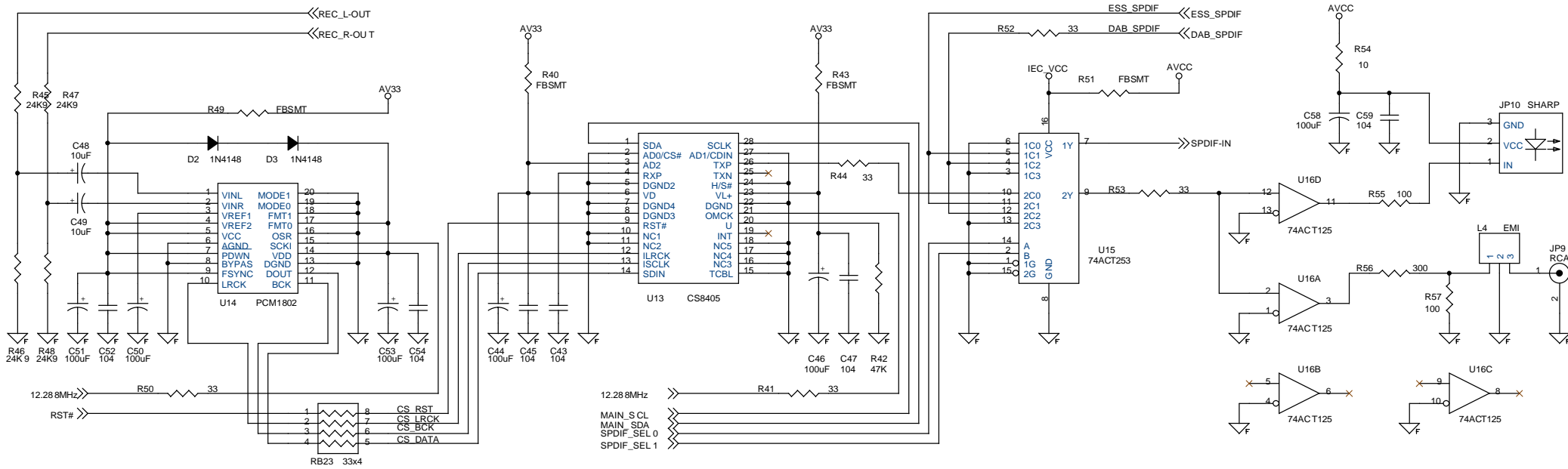

文件编号:	
编制:	审核:
主机型号: CDI10	硬件版本: 2005-08
文件名称: 主板原理图	
日期:	页次: 3/7

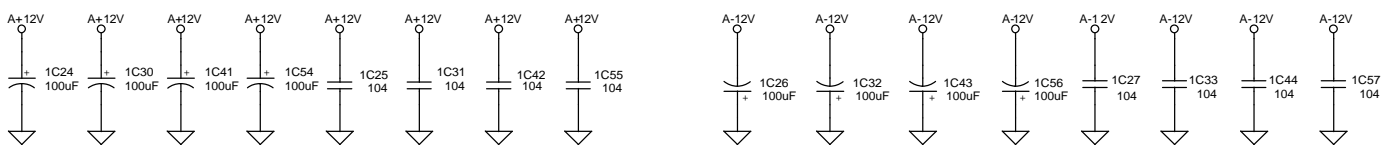
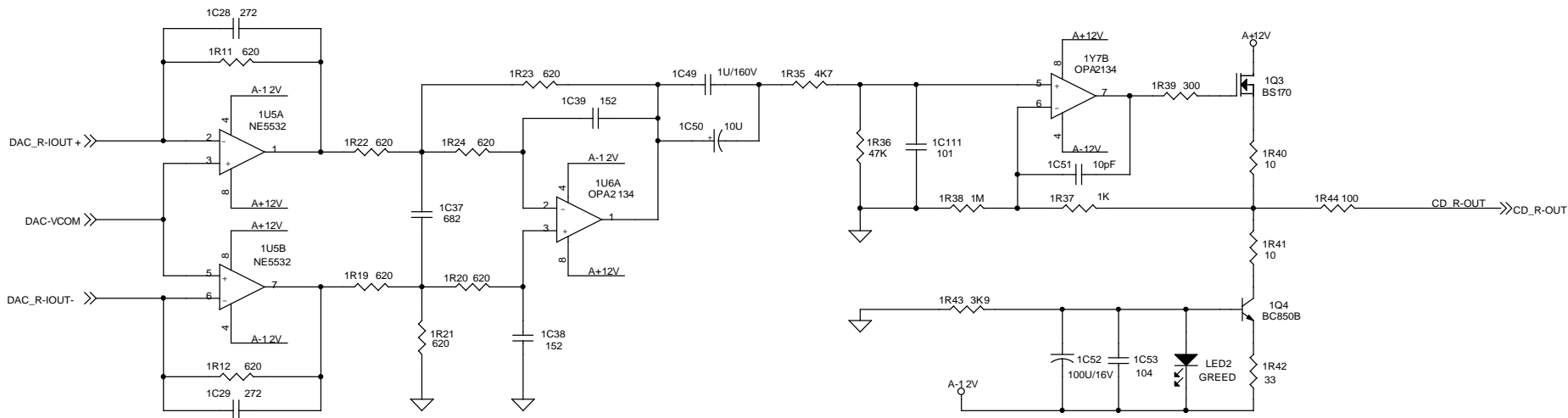
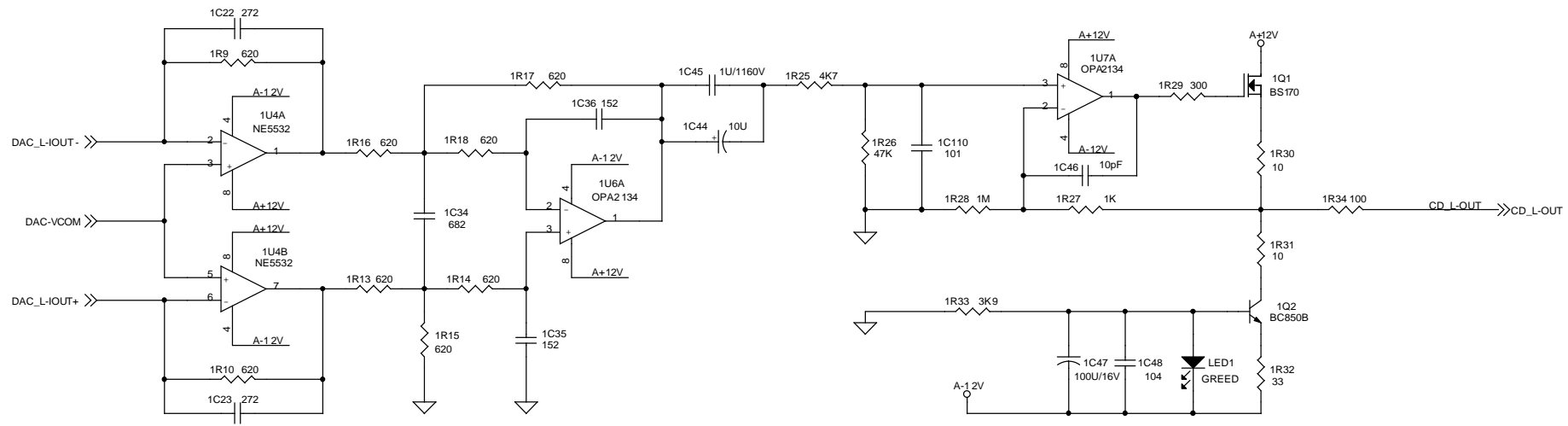

文件编号:	
拟制:	审核:
主机型号: CDI10	硬件版本: 2005-08
文件名称: 主板原理图	
日期:	页次: 4/7



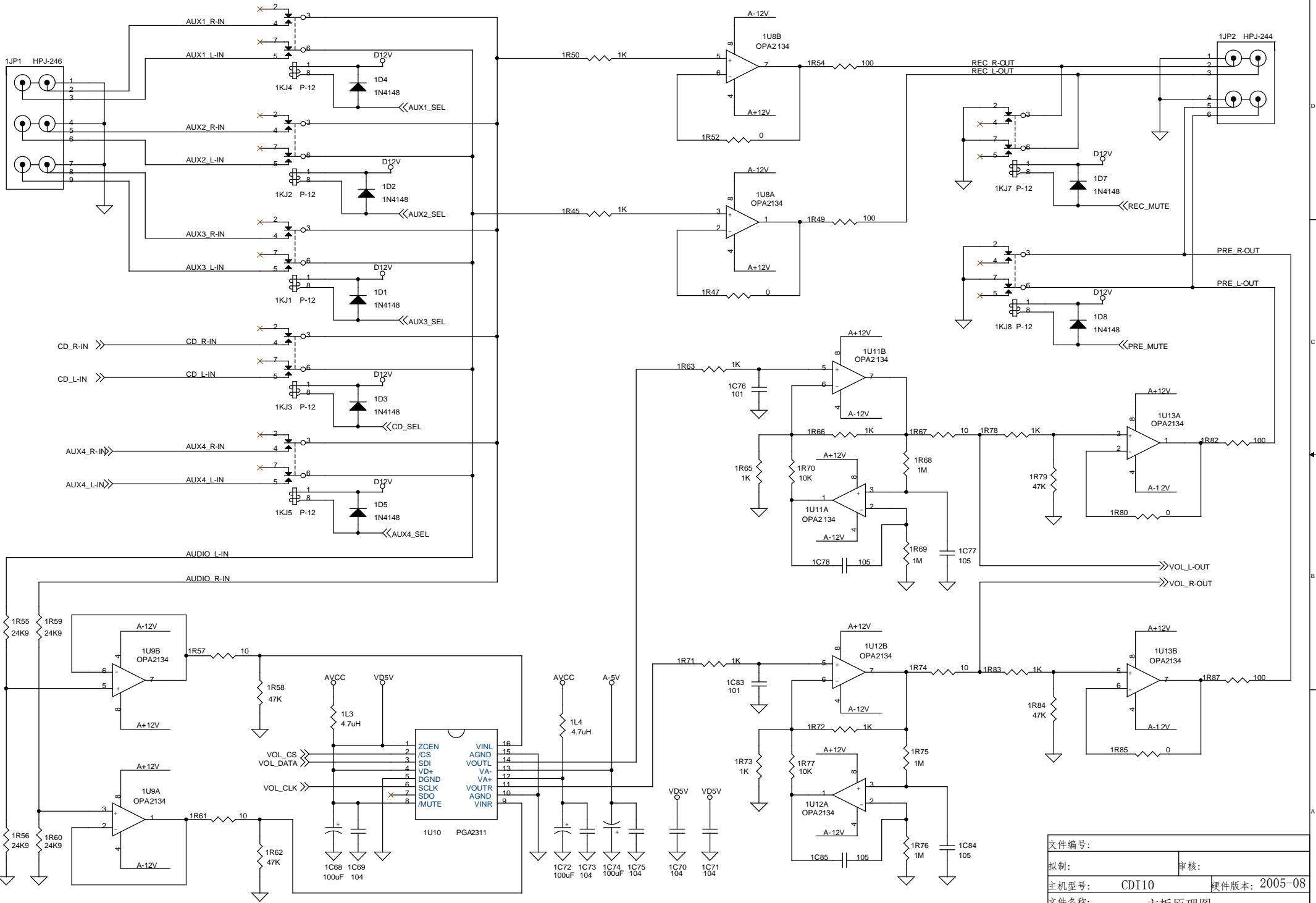

文件编号:	
拟制:	审核:
主机型号: CDI10	硬件版本: 2005-08
文件名称: 主板原理图	
日期:	页次: 5/7

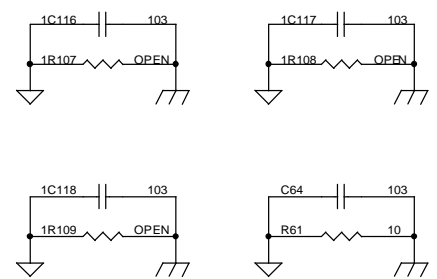
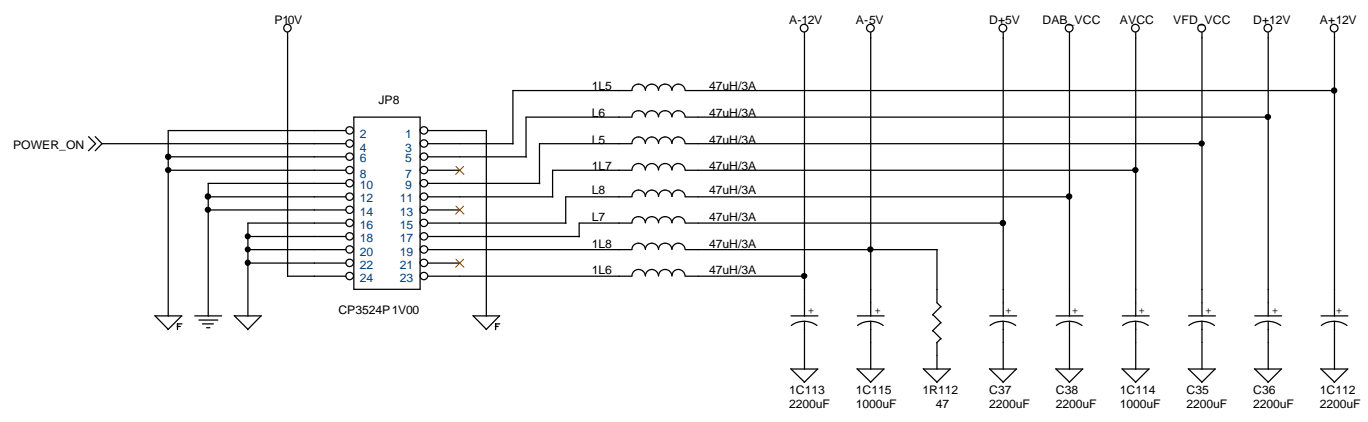
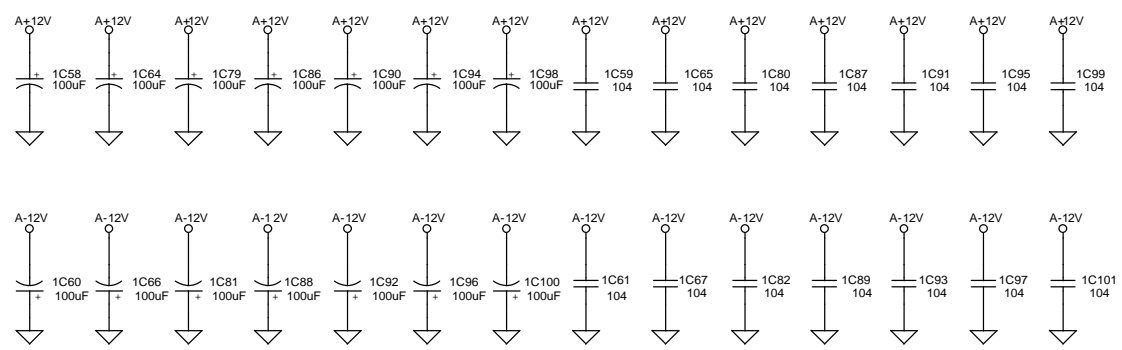
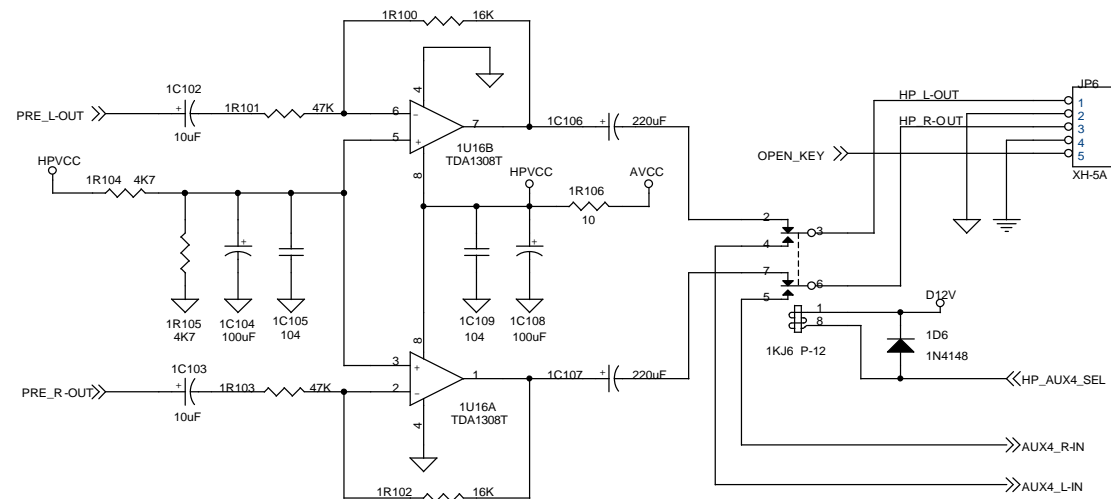
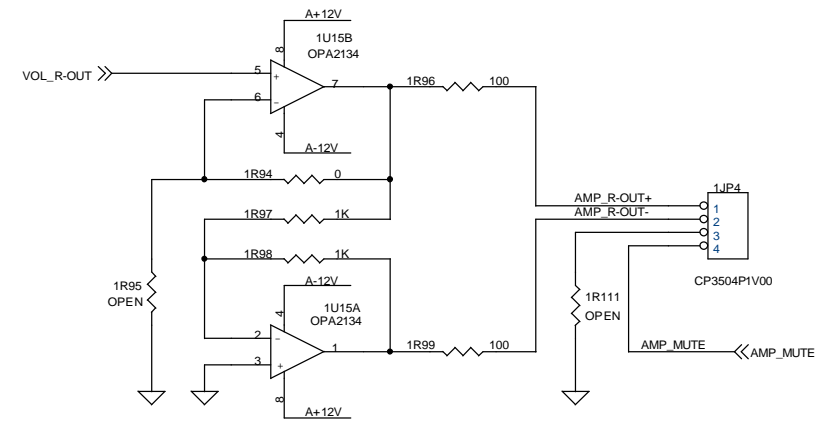
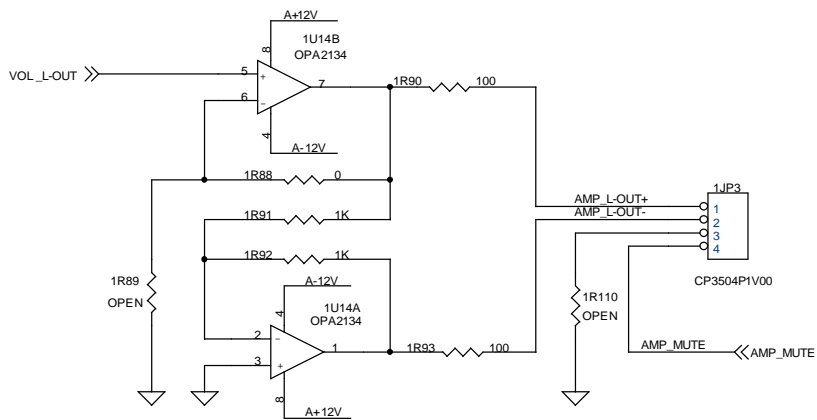

文件编号:	
编制:	审核:
主机型号: CDI10	硬件版本: 2005-08
文件名称: 主板原理图	
日期:	页次: 6/7

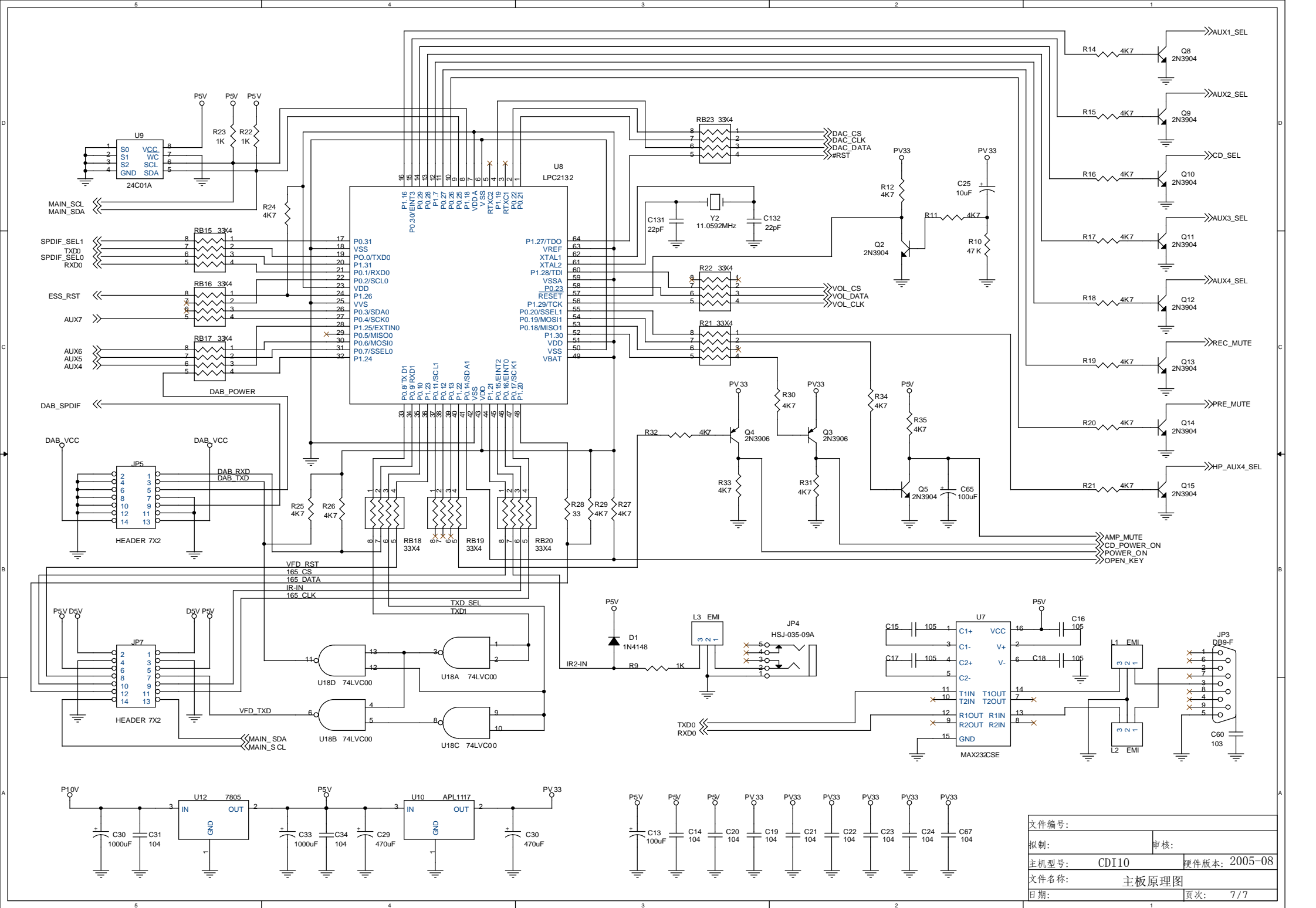

文件编号:	
编制:	审核:
主机型号: CDI10	硬件版本: 2005-08
文件名称: 主板原理图	
日期:	页次: 7/7

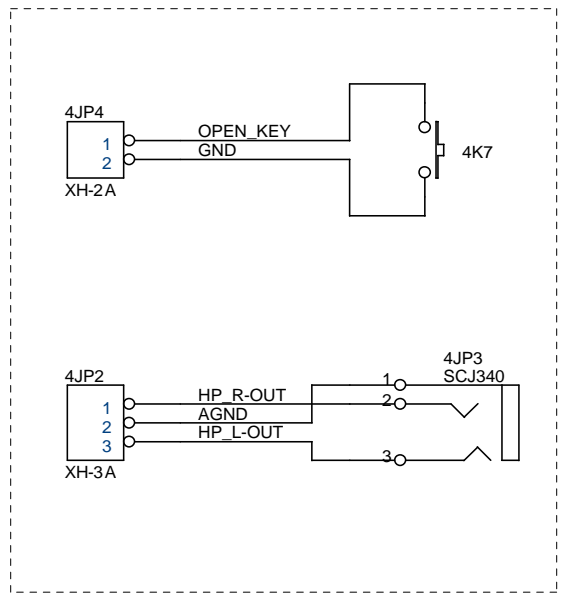
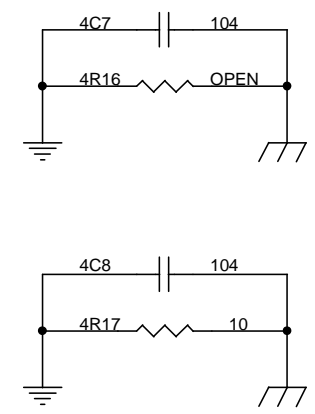
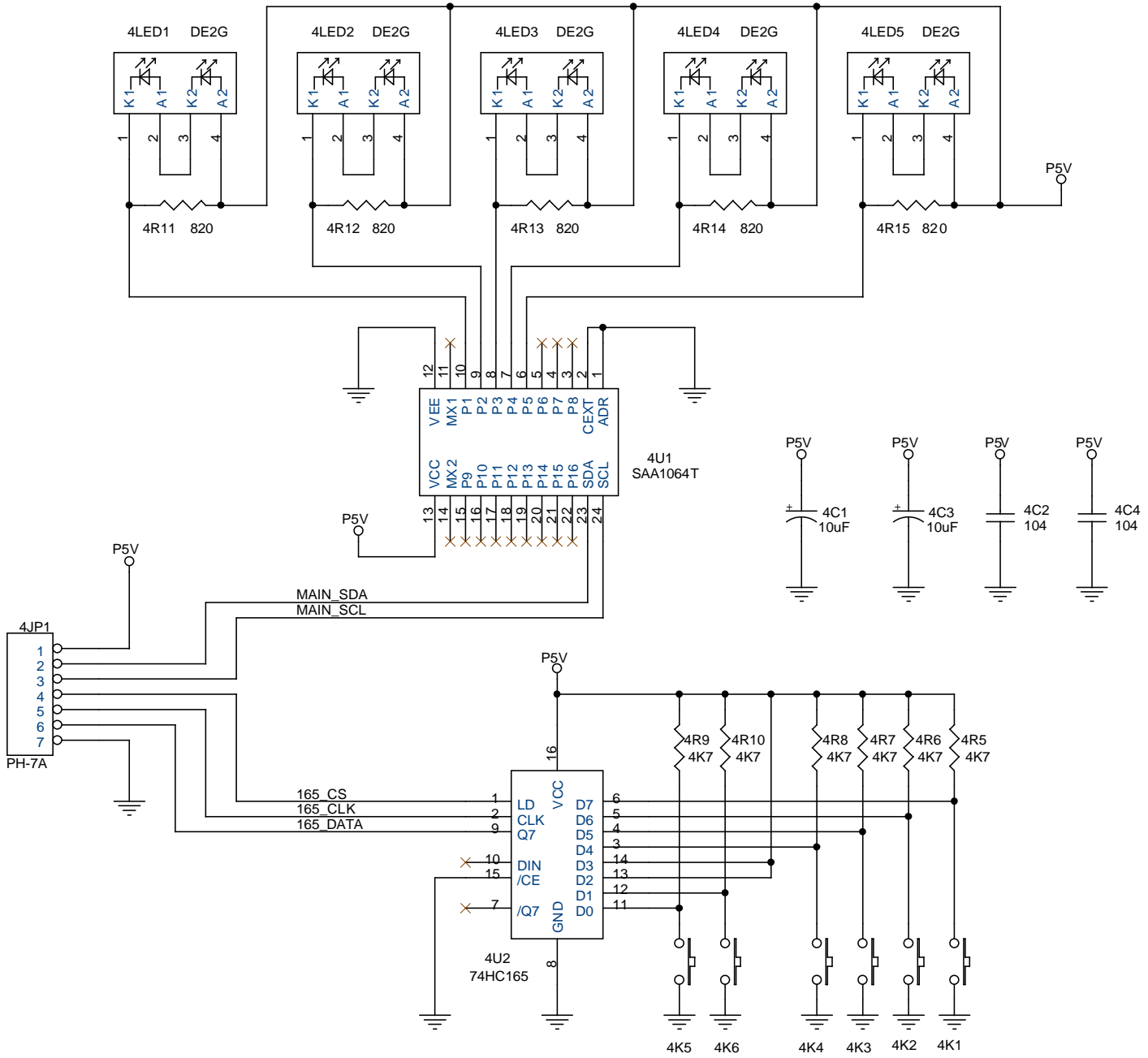

文件编号:	
拟制:	审核:
主机型号: CDI10	硬件版本: 2005-08
文件名称: 按键板原理图	
日期:	页次: 1/1

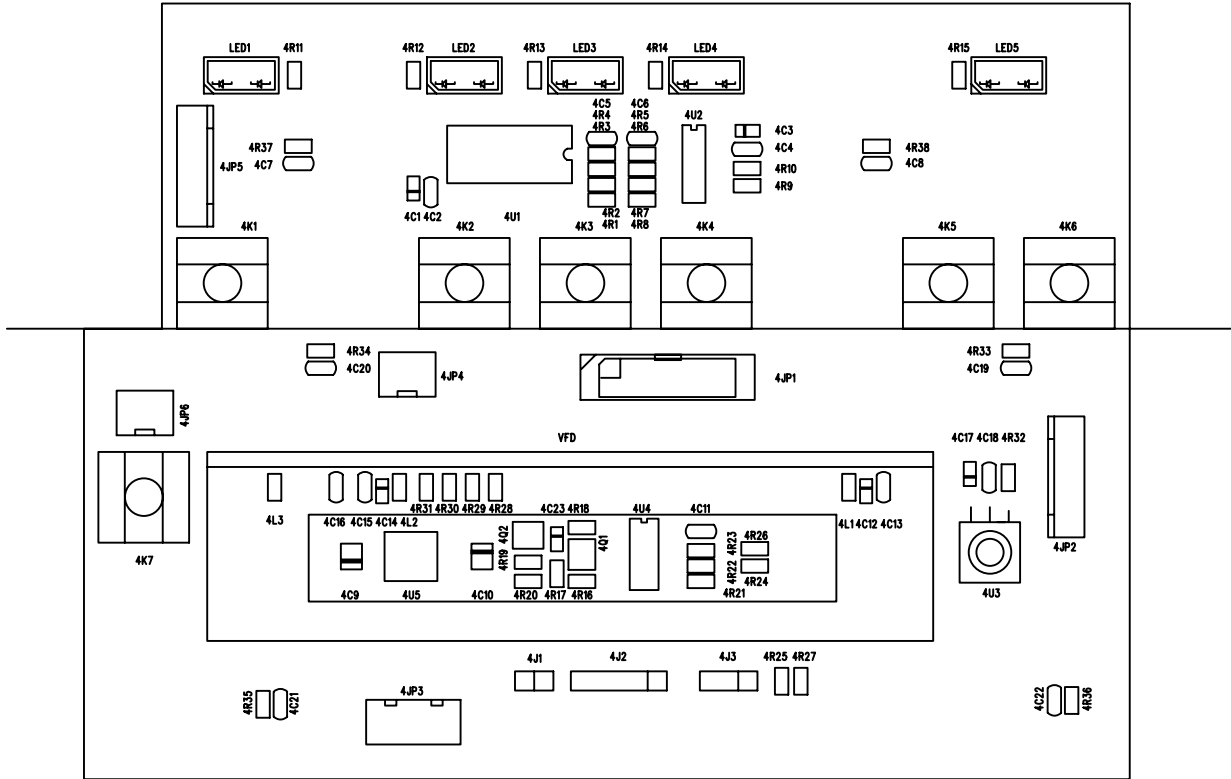

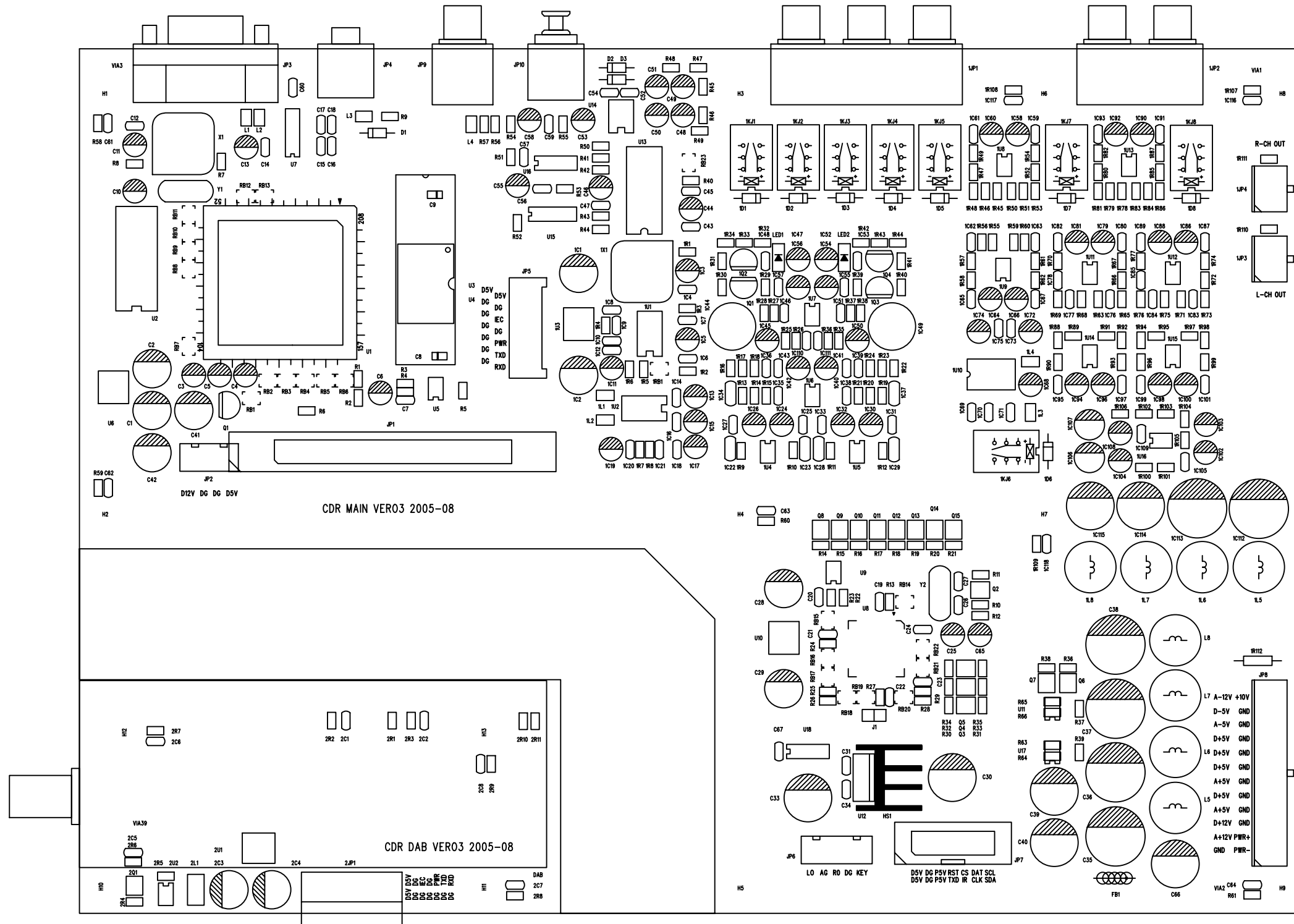

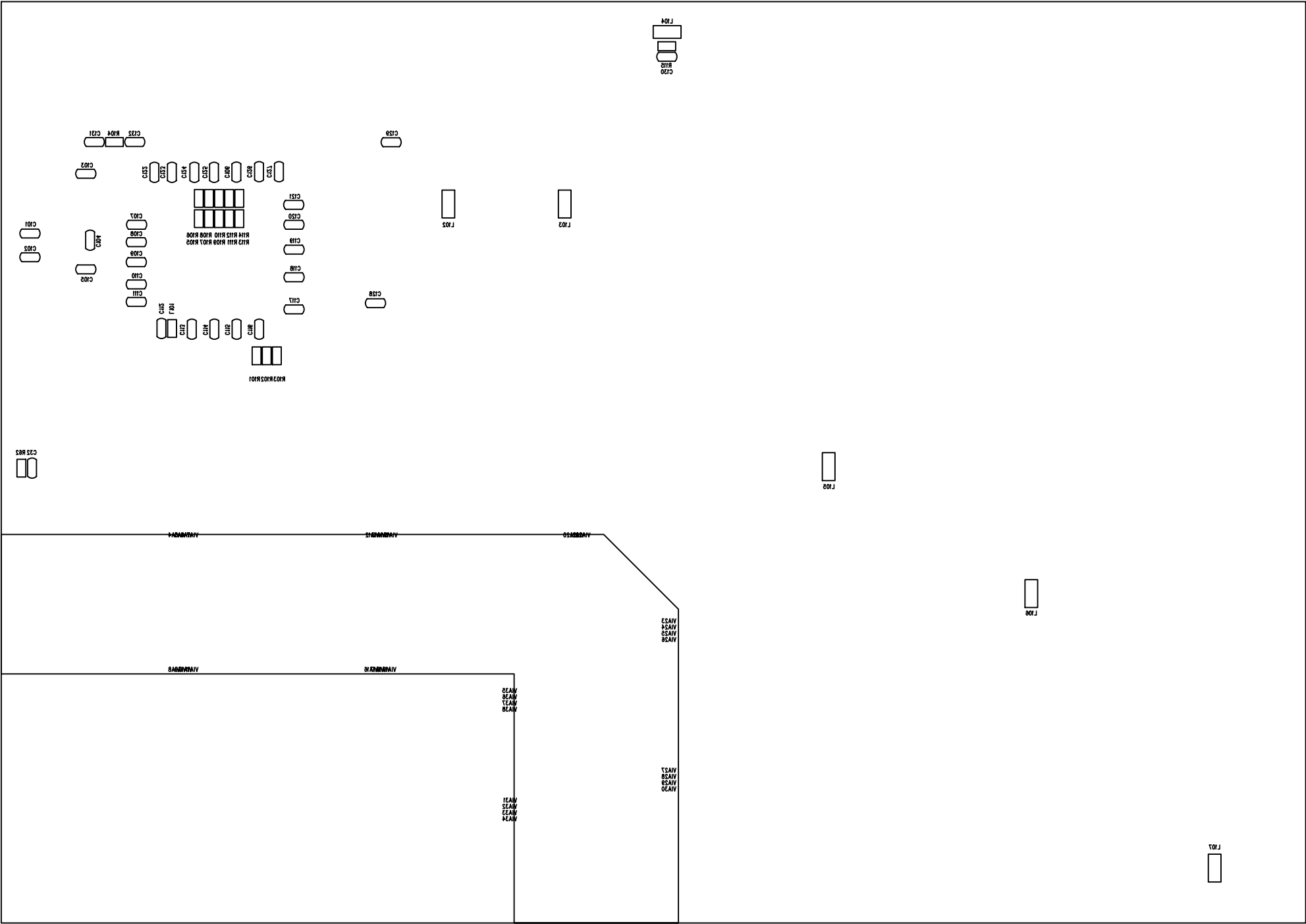

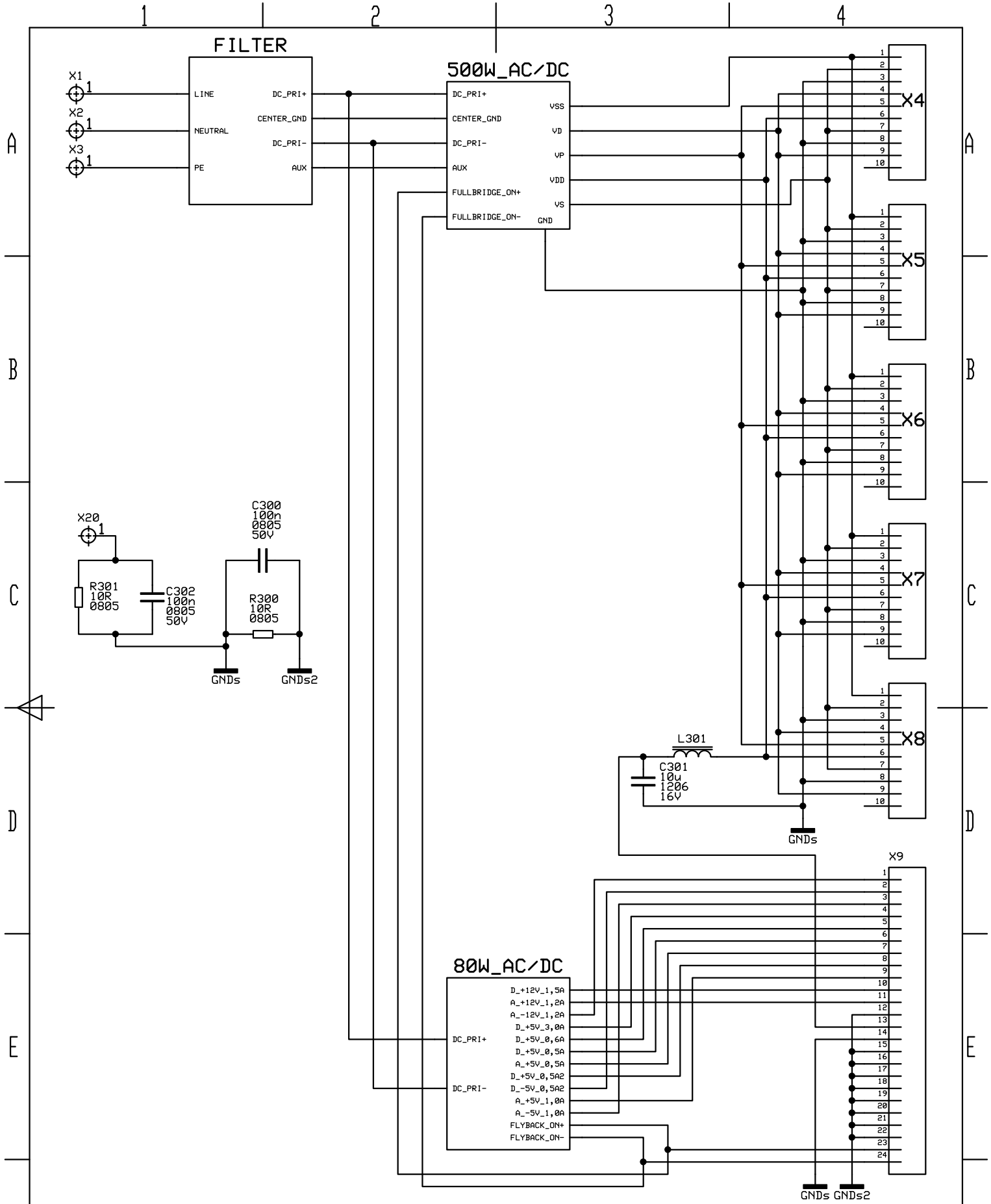

Designed by <b>Martin carlzon</b>	Checked by	Date <b>11/08/05</b>	Scale <b>A4</b>
<b>Anaview AB</b>		Filename <b>Sch-cb120_1 PB2</b>	
		Sheet <b>1 ( 4 )</b>	



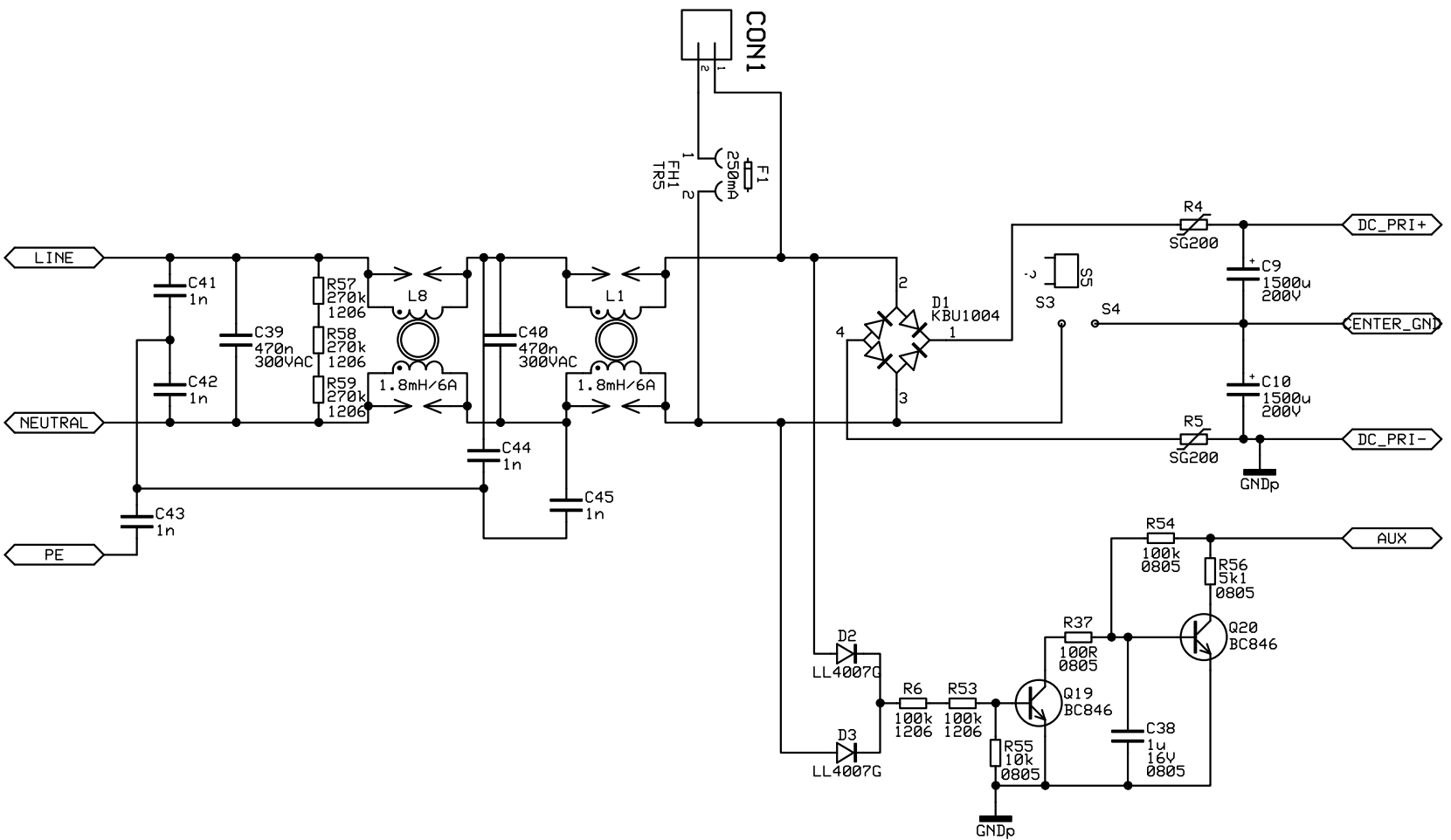

Designed by  
Martin carlizon

Checked by

Date  
11/08/05

Scale  
A4

Filename

Sch-cb120\_1 PB2

Anaview AB

FILTER

Sheet  
4 (4)

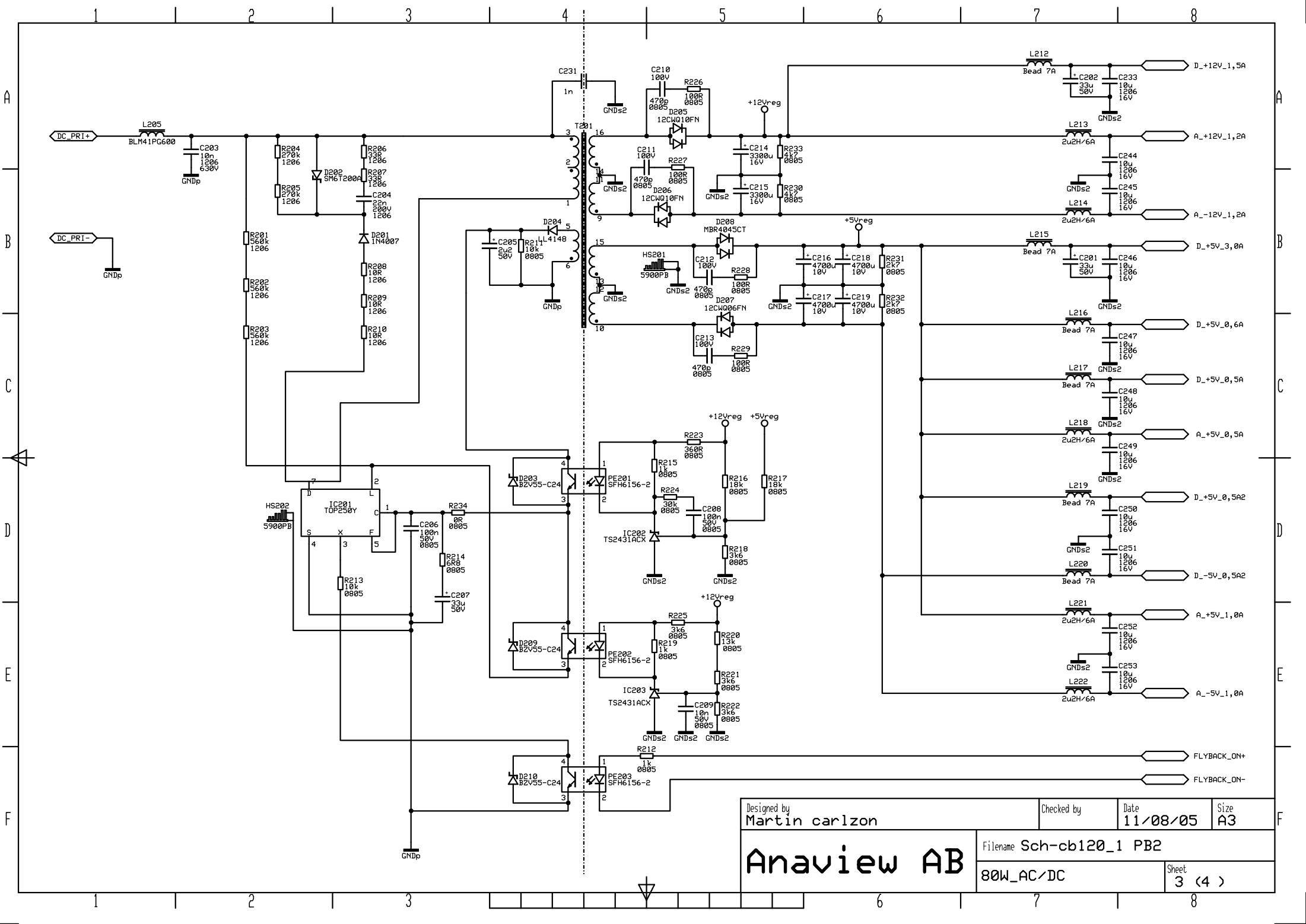

Designed by Martin carlzon	Checked by	Date 11/08/05	Size A3
<b>Anaview AB</b>		Filename Sch-cb120_1 PB2	
		80W_AC/DC	Sheet 3 ( 4 )

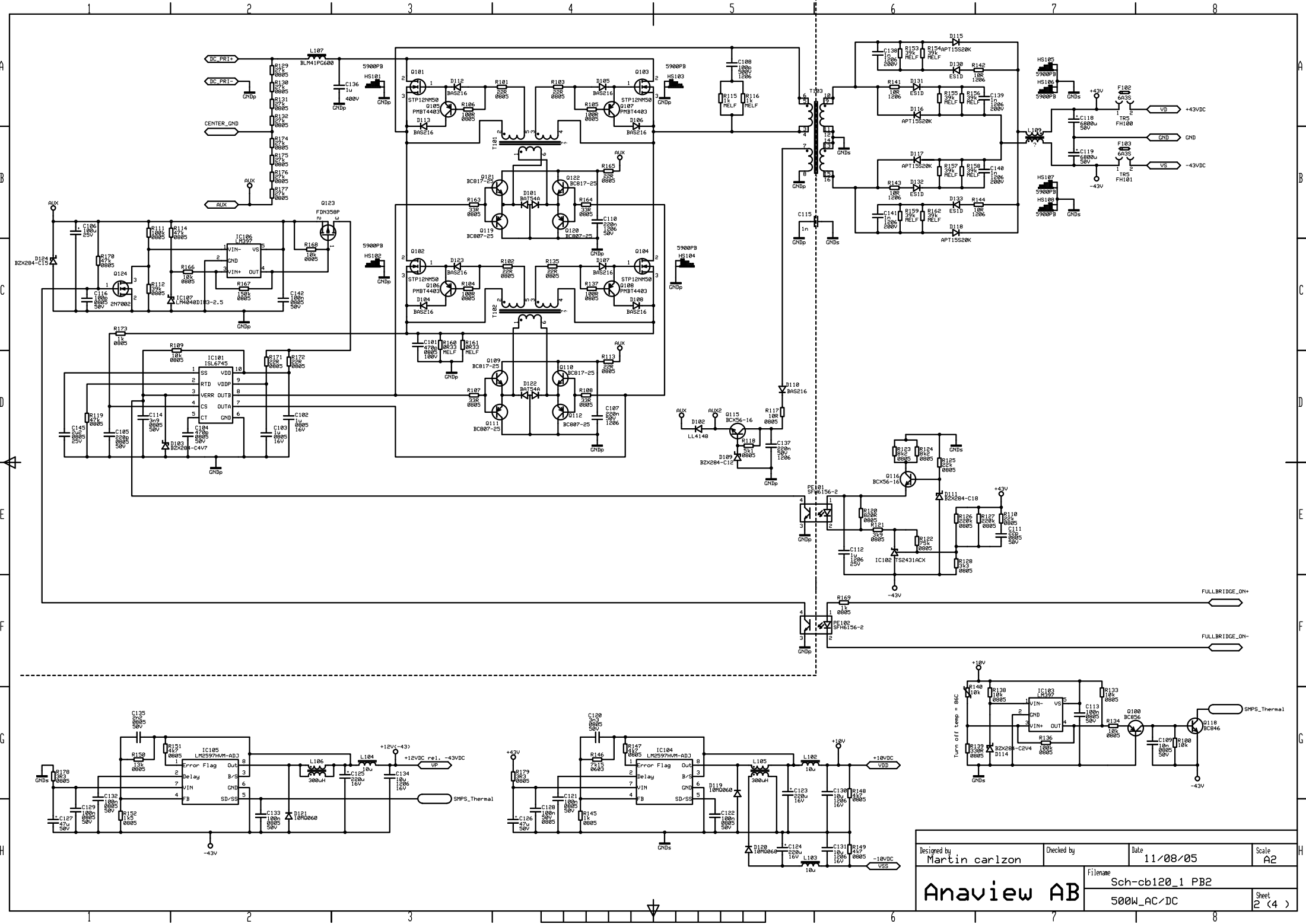

Designed by Martin Carlzon	Checked by Martin Carlzon	Date 11/08/05	Scale A2
Anaview AB		Filename Sch-cb120_1 PB2	Sheet 2 (4)
		500W_AC/DC	

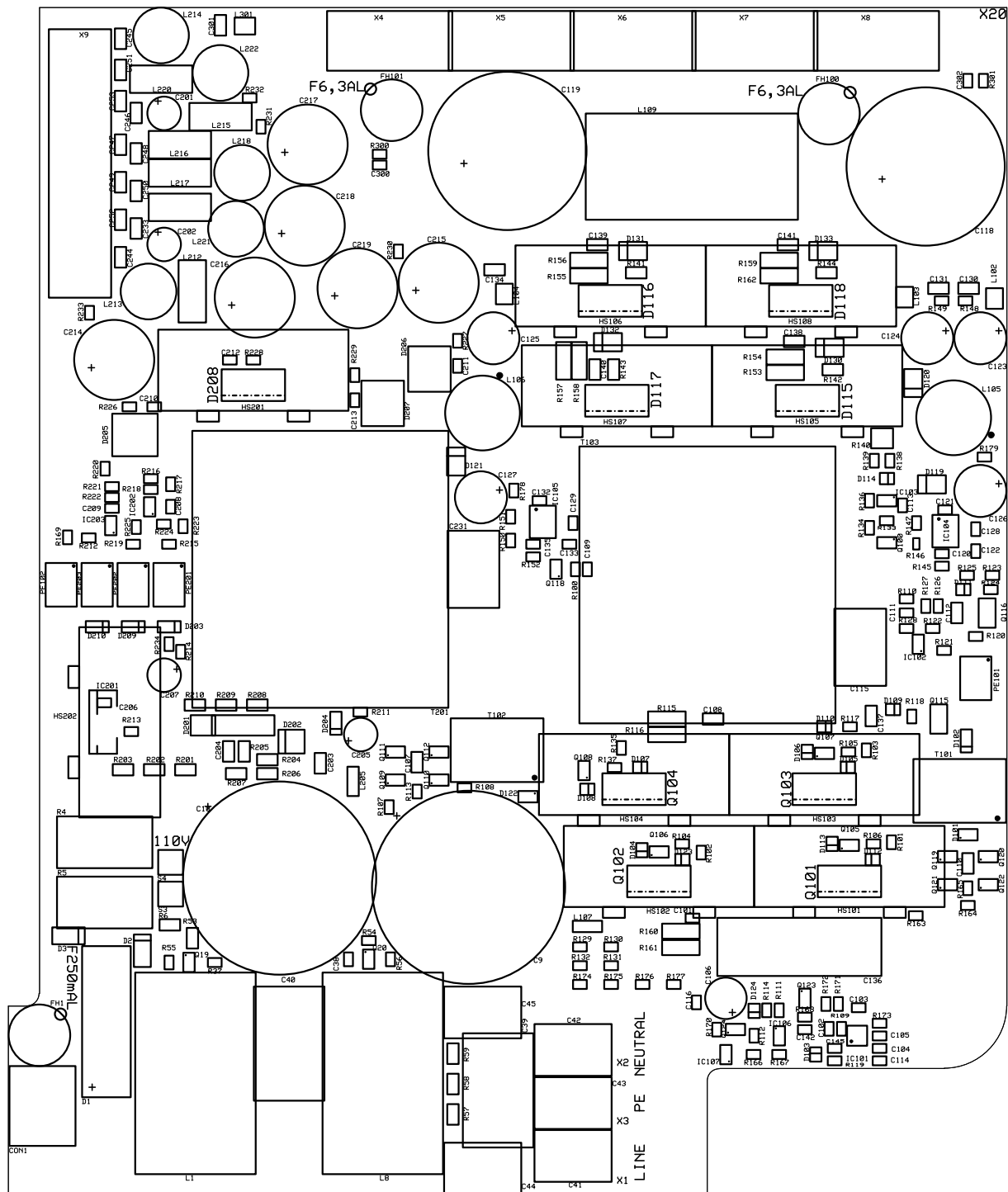

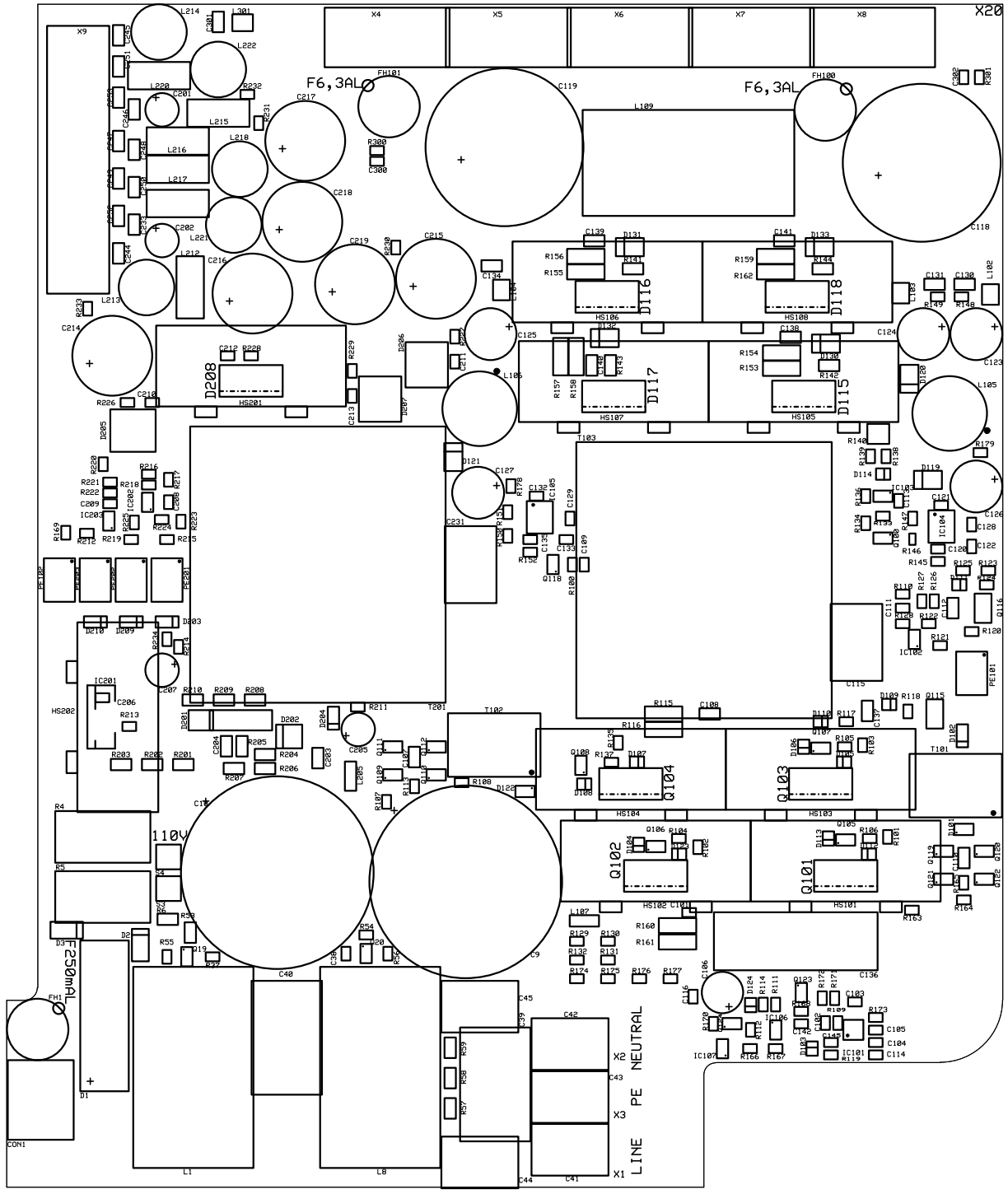

CONT

PERSONAL

LINE PE NEUTRAL

# **Performance Data / Extended features**

## **FM**

Stereo tuner, 87.5-108Mhz

RDS decoding

Number of Presets: 40

Usable sensitivity:        FM Mono 10dBuV  
                                 FM Stereo 20dBuV

## **DAB**

Band III (174-240Mhz) and L (1452-1492Mhz).

Usable Sensitivity: 29dBuV band III  
                                 30dBuV band L

Number of Presets 10

## **Input / outputs**

4 of Line inputs (3pcs RCA, 1pcs 3.5mm on the front)

1 Pre output (RCA)

1 Tape output (RCA)

1 75R SPDIF (RCA)

1 TOSlink

1 IR input

1 RS232 input

50R Antenna Input (F-connector) combined for DAB / FM.

## **Amplifier**

2x75W (8R load, 1K below 1% THD+N) class D amplifier.

THD+N 20Hz- 20Khz 10W below 0.1%

Frequency response 20Hz – 20Khz, +-0.3dB.

## **Power Supply**

Dual switchmode powersupply

Powerconsumtion:      Standby: 16W  
Operate: 210W