

GD54/74HC74, GD54/74HCT74

DUAL D-TYPE FLIP-FLOPS WITH PRESET & CLEAR

General Description

These devices are identical in pinout to the 54/74LS74. They consist of two D-type flip-flops with individual preset, clear, and clock inputs. Information at a D-input is transferred to the corresponding Q output on the next positive going edge of the clock input. Both Q and \bar{Q} outputs are available from each flip-flop. The preset & clear inputs are asynchronous. These devices are characterized for operation over wide temperature ranges to meet industry and military specifications.

Features

- Low Power consumption characteristic of CMOS devices
- Output drive capability: 10 LS TTL Loads Min.
- Operating speed superior to LS TTL
- Wide operating voltage range: for HC 2 to 6 volts
for HCT 4.5 to 5.5 volts
- Low input current: 1 μ A Max.
- Low quiescent current: 40 μ A Max. (74HC)
- High noise immunity characteristic of CMOS
- Diode protection on all inputs

Logic Diagram

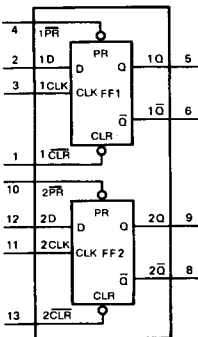
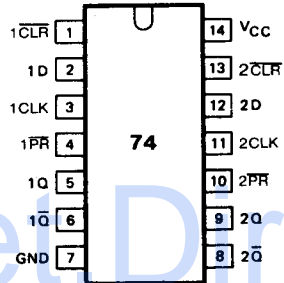

Fig. 1 Logic diagram

Pin Configuration



Suffix-Blank : Plastic Dual In Line Package
 Suffix-J : Ceramic Dual In Line Package
 Suffix-D : Small Outline Package

Function Table

INPUTS				OUTPUTS	
\overline{PR}	\overline{CLR}	CLK	nD	nQ	n \overline{Q}
L	H	X	X	H	L
H	L	X	X	L	H
L	L	X	X	H	H

INPUTS				OUTPUTS	
\overline{PR}	\overline{CLR}	CLK	nD	Q _{n+1}	\overline{Q}_{n+1}
H	H	↑	L	L	H
H	H	↑	H	H	L

H = HIGH voltage level
 L = LOW voltage level
 X = don't care
 ↑ = LOW-to-HIGH CLK transition
 Q_{n+1} = state after the next LOW-to-HIGH CLK transition

Absolute Maximum Ratings

SYMBOL	PARAMETER	CONDITIONS	MIN.	MAX.	UNIT
V_{CC}	DC Supply voltage		-0.5	+7	V
I_{IK}, I_{OK}	DC input or output diode current	for $V_I < -0.5$ or $V_I > V_{CC} + 0.5V$		20	mA
I_O	DC output source or sink current	for $-0.5V < V_O < V_{CC} + 0.5V$		25	mA
I_{CC}	DC V_{CC} or GND current			50	mA
T_{sto}	Storage temperature range		-65	150	°C
P_D	Power dissipation per package	above +70°C: derate linearly with 8mW/K		500	mW
T_L	Lead temperature	At distance 1/16 ± 1/32 in. from case for 60 sec(CERAMIC) 10 sec(PLASTIC)		300 260	°C

Recommended Operating Conditions

CHARACTERISTIC	LIMITS		UNITS
	MIN.	MAX.	
Supply-Voltage Range V_{CC} : GD54/74HC Types GD54/74HCT Types	2 4.5	6 5.5	V
DC Input or Output Voltage V_I, V_O	0	V_{CC}	V
Operating Temperature T_A : GD74 Types GD54 Types	-40 -55	+85 +125	°C
Input Rise and Fall times t_r, t_f : GD54/74HC Types at 2V at 4.5V at 6V GD54/74HCT Types at 4.5V		1000 500 400 500	ns

Logic diagram

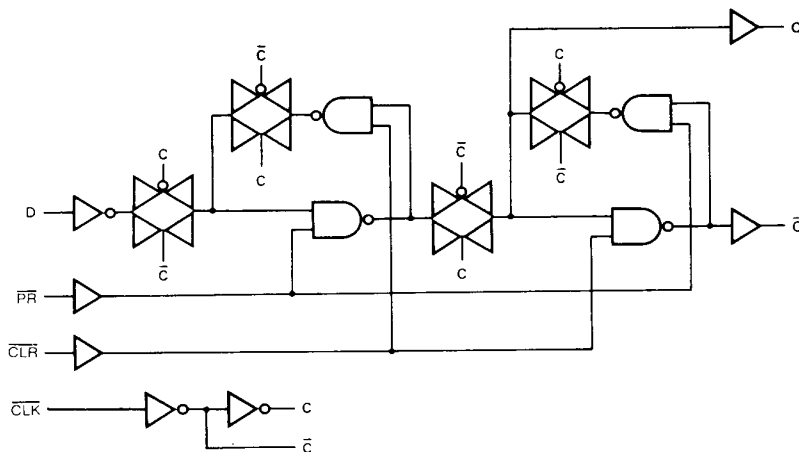

Fig. 2 Logic diagram (one flip-flop)

DC Electrical Characteristics for HC

SYMBOL	PARAMETER	TEST CONDITION	V _{CC} (V)	T _A =25°C			GD74HC 74		GD54HC 74		UNIT	
				MIN.	TYP.	MAX.	MIN.	MAX.	MIN.	MAX.		
V _{IH}	HIGH level input Voltage		2.0	1.5			1.5		1.5		V	
			4.5	3.15			3.15		3.15			
			6.0	4.2			4.2		4.2			
V _{IL}	LOW level input voltage		2.0			0.3		0.3		0.3	V	
			4.5			0.9		0.9		0.9		
			6.0			1.2		1.2		1.2		
V _{OH}	HIGH level output voltage	V _{IN} =V _{IH}	I _{OH} =-20μA	2.0	1.9	2.0		1.9		1.9	V	
			4.5	4.4	4.5		4.4		4.4			
		or V _{IL}	I _{OH} =-4mA	4.5	3.98	4.3		3.84		3.7		
			I _{OH} =-5.2mA	6.0	5.48	5.2		5.34		5.2		
V _{OL}	LOW level output voltage	V _{IN} =V _{IH}	I _{OL} =20μA	2.0			0.1		0.1		V	
			4.5			0.1		0.1		0.1		
		or V _{IL}	I _{OL} =4mA	4.5		0.17	0.26		0.33			0.4
			I _{OL} =5.2mA	6.0		0.15	0.26		0.33			0.4
I _{IN}	Input leakage Current	V _{IN} =V _{CC} or GND	6.0			0.1		1.0		1.0	μA	
I _{CC}	Quiescent Supply Current	V _{IN} =V _{CC} or GND I _{out} =0μA	6.0			4		40		80	μA	

DC Electrical Characteristics for HCT

SYMBOL	PARAMETER	TEST CONDITION	V _{CC} (V)	T _A =25°C			GD74HCT74		GD54HCT74		UNIT	
				MIN.	TYP.	MAX.	MIN.	MAX.	MIN.	MAX.		
V _{IH}	HIGH level input Voltage		4.5 to 5.5	2.0			2.0		2.0		V	
V _{IL}	LOW level input voltage		4.5 to 5.5			0.8		0.8		0.8	V	
V _{OH}	HIGH level output voltage	V _{IN} =V _{IH}	I _{OH} =-20μA	4.5	4.4	4.5		4.4		4.4	V	
			4.5	3.98	4.3		3.84		3.7			
		or V _{IL}	I _{OH} =-4mA	4.5	3.98	4.3		3.84		3.7		
V _{OL}	LOW level output voltage	V _{IN} =V _{IH}	I _{OL} =20μA	4.5			0.1		0.1		V	
			4.5			0.1		0.1		0.1		
		or V _{IL}	I _{OL} =4mA	4.5		0.17	0.26		0.33			0.4
I _{IN}	Input leakage Current	V _{IN} =V _{CC} or GND	5.5			0.1		1.0		1.0	μA	
I _{CC}	Quiescent Supply Current	V _{IN} =V _{CC} or GND I _{out} =0μA	5.5			4		40		80	μA	

Timing Requirements for HC: $t_r=t_f=6ns$ $C_L=50$ pF

SYMBOL	PARAMETER		V _{CC} (V)	T _A =25°C			GD74HC74		GD54HC74		UNIT
				MIN.	TYP.	MAX.	MIN.	MAX.	MIN.	MAX.	
t _w	Pulse width	PR or CLR (low)	2.0	80	30		100		120		ns
			4.5	16	10		20		25		
			6.0	14	8		18		22		
		CLK (high or low)	2.0	80	30		100		120		
			4.5	16	10		20		25		
			6.0	14	8		18		22		
t _{su}	Setup time	Data before CLK ↑	2.0	60	30		80		100		ns
			4.5	15	10		18		20		
			6.0	14	8		16		18		
t _{rec}	Recovery time	PR or CLR inactive	2.0	5	0		5		5		ns
			4.5	5	0		5		5		
			6.0	5	0		5		5		
t _h	Hold time	Data after CLK ↑	2.0	3	0		3		3		ns
			4.5	3	0		3		3		
			6.0	3	0		3		3		

AC Characteristics for HC: $t_r=t_f=6ns$ $C_L=50$ pF

SYMBOL	PARAMETER		V _{CC} (V)	T _A =25°C			GD74HC74		GD54HC74		UNIT
				MIN.	TYP.	MAX.	MIN.	MAX.	MIN.	MAX.	
f _{max}	Maximum Clock Pulse Frequency	2.0	6	20		5		4		MHz	
		4.5	30	65		25		20			
		6.0	35	75		30		25			
t _{PLH} / t _{PHL}	Propagation Delay Time nCLK to nQ, nQ̄	2.0		45	170		210		250	ns	
		4.5		15	30		40		50		
		6.0		14	28		35		45		
t _{PLH} / t _{PHL}	Propagation Delay Time nPR to nQ, nQ̄	2.0		45	180		220		260	ns	
		4.5		14	32		42		52		
		6.0		13	28		35		45		
t _{PLH} / t _{PHL}	Propagation Delay Time nCLR to nQ, nQ̄	2.0		45	180		220		260	ns	
		4.5		14	32		42		52		
		6.0		13	28		35		45		
t _{TLH} / t _{THL}	Output Transition Time	2.0		25	70		85		100	ns	
		4.5		8	15		18		22		
		6.0		7	13		16		18		

Timing Requirements for HCT : $t_r=t_f=6ns$ $C_L=50$ pF

SYMBOL	PARAMETER		V _{CC} (V)	T _A =25°C			GD74HCT74		GD54HCT74		UNIT
				MIN.	TYP.	MAX.	MIN.	MAX.	MIN.	MAX.	
t _w	Pulse width	\overline{PR} or \overline{CLR} (low)	4.5	18	10		20		25		ns
		CLK (high or low)	4.5	16	10		20		25		ns
t _{su}	Setup time	Data before CLK ↑	4.5	15	10		18		20		ns
t _{rec}	Recovery time	\overline{PR} or \overline{CLR} inactive	4.5	5	0		5		5		ns
t _h	Hold time	Data after CLK ↑	4.5	3	0		3		3		ns

AC Characteristics for HCT : $t_r=t_f=6ns$ $C_L=50$ pF

SYMBOL	PARAMETER		V _{CC} (V)	T _A =25°C			GD74HCT74		GD54HCT74		UNIT
				MIN.	TYP.	MAX.	MIN.	MAX.	MIN.	MAX.	
f _{max}	Maximum Clock Pulse Frequency		4.5	27	54		22		18		MHz
t _{PLH} / t _{PHL}	Propagation Delay Time nCLK to nQ, n \overline{Q}		4.5		18	35		44		53	ns
t _{PLH} / t _{PHL}	Propagation Delay Time n \overline{PR} to nQ, n \overline{Q}		4.5		20	35		44		53	ns
t _{PLH} / t _{PHL}	Propagation Delay Time n \overline{CLR} to nQ, n \overline{Q}		4.5		20	35		44		53	ns
t _{TLH} / t _{THL}	Output Transition Time		4.5		8	15		18		22	ns

AC Waveform

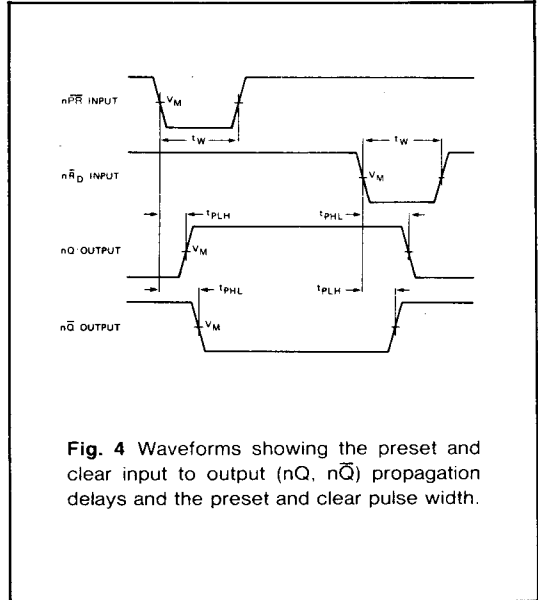
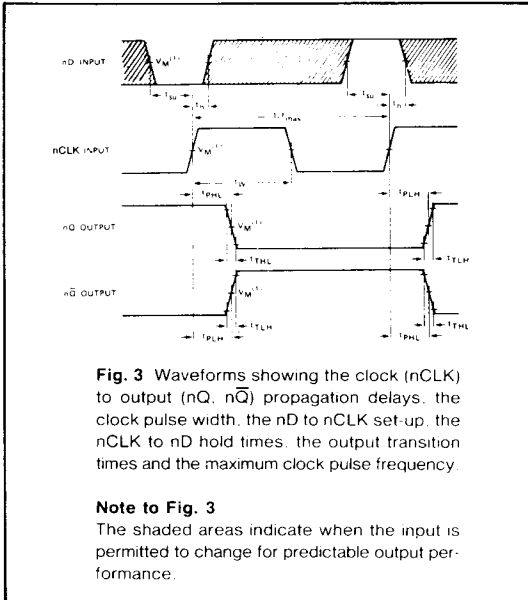

Note to AC waveforms

- (1) HC: $V_M = 50\%$, $V_i = \text{GND to } V_{CC}$.
- HCT: $V_M = 1.3V$, $V_i = \text{GND to } 3V$.