

SERVICE MANUAL FOR

8224



BY: Star Meng

Validation Tool Research Department /EDVD

Mar.2006 / R01



8224 N/B Maintenance

Contents

1. Hardware Engineering Specification	4
1.1 Introduction	4
1.2 Hardware System	8
1.3 Other Functions	38
1.4 Power Management	44
1.5 Appendix 1: Intel ICH7-M GPIO Definitions	47
1.6 Appendix 2: W83L951DG GPIO Definitions	49
2. System View and Disassembly	54
2.1 System View	54
2.2 Tools Introduction	57
2.3 System Disassembly	58
3. Definition & Location of Connectors / Switches	78
3.1 Mother Board	78
3.2 Daughter Board	81
4. Definition & Location of Major Components	82
4.1 Mother Board	82
5. Pin Description of Major Components	84
5.1 Intel 945/945P North Bridge	84
5.2 Intel ICH7-M South Bridge	90

8224 N/B Maintenance

Contents

6. System Block Diagram	101
7. Maintenance Diagnostics	102
7.1 Introduction	102
7.2 Error Codes	103
7.3 Debug Tool	105
8. Trouble Shooting	107
8.1 No Power	109
8.2 No Display	115
8.3 TV Out Test Error	118
8.4 VGA Controller Test Error LCD No Display	120
8.5 External Monitor No Display	122
8.6 Memory Test Error	125
8.7 Keyboard (K/B) Touch-Pad (T/P) Test Error	127
8.8 Hard Driver Test Error	129
8.9 CD-ROM Driver Test Error	131
8.10 USB Port Test Error	133
8.11 New Card Socket Test Error	136
8.12 Blue Tooth Test Error	138
8.13 Mini-PCI Socket Test Error	140
8.14 CardReader & IEEE1394 Socket Test Error	143
8.15 Audio Test Error	146

8224 N/B Maintenance

Contents

8.16 LAN Test Error	149
9. Spare Parts List	151
10. System Exploded Views	163
11. Reference Material	165

MiTac Secret
Confidential Document

8224 N/B Maintenance

1. Hardware Engineering Specification

1.1 Introduction

1.1.1 General Description

This document describes the brief introduction for MiTAC 8224 portable notebook computer system.

1.1.2 System Overview

The MiTAC 8224 model is designed for Intel Mobile Pentium-M Processor Yonah 533 and 667 FSB.

This system is based on PCI architecture and is fully compatible with IBM PC/AT specification, which has standard hardware peripheral interface. The power management complies with Advanced Configuration and Power Interface. It also provides easy configuration through CMOS setup, which is built in system BIOS software and can be pop-up by pressing F2 key at system start up or warm reset. System also provides icon LEDs to display system status, such as AC Power indicator, Battery Power indicator, Battery status indicator, HDD, CD-ROM, NUM LOCK, CAP LOCK, SCROLL LOCK. It also equipped with GIGA LAN, 56K Fax MODEM, 4 USB port, S-Video and audio line out, SPIDIF, and internal/external microphone function.

The memory subsystem supports DDR2 SDRAM channels (64-bits wide).

The 945GM MCH Host Memory Controller integrates a high performance host interface for Intel Yonah processor,

8224 N/B Maintenance

a high performance PCI Express interface, a high performance memory controller, Digital Video port (DVOB & DVOC) interface, and Direct Media Interface (DMI) connecting with Intel ICH7-M.

The Intel ICH7-M integrates three Universal Serial Bus 2.0 Host Controllers Interface (UHCI), the Audio Controller with Azalia interface, the Ethernet includes a 32-bit PCI controller, the IDE Master/Slave controllers, the SATA controller and Direct Media Interface technology.

Intel Graphics enhancements includes DVMT 3.0 , Zone Rendering 2.0, Quad pixel pipe rendering engine, Pixel Shader 2.0 and 4x Faster Setup Engine.

The BCM5789 is a highly integrated, cost-effective single-chip Fast Ethernet controller that provides 32-bit performance, PCI bus master capability, and full compliance with IEEE 802.3u 100Base-T specifications and IEEE 802.3x Full Duplex Flow Control. It also supports the Advanced Configuration Power management Interface (ACPI).

The Texas Instruments PCI8402 controller is an integrated single-socket IEEE 1394 open HCI host controller and one-port PHY and flash media controller. This high-performance integrated solution provides the latest in IEEE 1394, SD, MMC, Memory Stick/PRO, SmartMedia, and xD technology.

The ALC880 2-Channel High Definition Audio Codec with UAA (Universal Audio Architecture), featuring a 24-bit two-channel DAC and two stereo 20-bit ADCs, are designed for commercial Notebook PC system. The ALC880 provide 2 output channels, along with flexible mixing, mute, and fine gain control functions. Also, supporting 32-bit S/PDIF input and output functions and a sampling rate of up to 96kHz.

The W83L951D is a high performance microcontroller on-chip supporting functions optimized for embedded control. These include ROM, RAM, four types of timers, a serial communication interface, optional I²C bus

8224 N/B Maintenance

interface, host interface, A/D converter, D/A converter, I/O ports, and other functions needed in control system configurations, so that compact, high performance systems can be implemented easily.

A full set of software drivers and utilities are available to allow advanced operating systems such as Windows ME, Windows 2000 and Windows XP to take full advantage of the hardware capabilities. Features such as bus mastering IDE, Plug and Play, Advanced Power Management (APM) with application restart, software-controlled power shutdown.

Following chapters will have more detail description for each individual sub-systems and functions.

MiTac Secret
Confidential Document

8224 N/B Maintenance

1.1.3 System Parts

Item	Description
CPU	Mobile Pentium-M Processor Yonah 533 and 667 FSB Thermal spec 40 W TDP
Core Logic	Intel 945GM(PM) + ICH7-M chipset
System BIOS	SST49LF004A
Memory	DDR2 533 256 MB: Nanya NT256T64UH4A0FN-37B Micron MT4HTF3264HY-53EB3 DDR2 533 512 MB: Nanya NT512T64UH8A0FN-37B Micron MT8HTF6464HDY-53EB3
HDD	SATA: Fujitsu: MHT2060BH, 60 GB PATA: Fujitsu: MHT2060AT+, 60 GB
ODD	COMBO : Lite-On LSC-2483K or KME-UJDA 760
Display	14.1W": AUO B141XG05 CHI-MEI N14111-L02
Clock Generator	ICS 9LPR310
Video Control	Intel 945GM ATI: M56-P with 8 cells 32 MB GDDR2 memory
LAN	BCM5787
Card Reader + IEEE1394	PCI8402ZHK
Audio System	Azalia CODEC: ALC880
Modem	56 Kbps (V.90) Fax Modem(MDC(Azalia I/F)) and 10/100(Reserved for 1000) Base-TX LAN Ekron (10/100) or Vidalia (GbE)
Wireless LAN	Wireless LAN Intel Pro/Wireless 3945ABG(Mini PCI-E Interface IEEE802.11a, b, g)with RF(USB interface)
CIR	IRM-2638
USB	USB2.0 x 4 (individual) Internal USB: Blue Tooth
TV Tuner Card	Mini-PCI-E A VerMedia Hybrid TV Tuner Card
New Card	Mini-PCI-E interface

8224 N/B Maintenance

1.2 Hardware System

1.2.1 Intel Yonah Processors in Micro-FCBGA Package

Intel Yonah Processors with 478 pins Micro-FCBGA package. The Yonah processor is built on Intel's next generation 65 nanometer process technology. Yonah is Intel's first dual core processor for mobile. The following list provides some of the key features on this processor:

- First dual core processor for mobile
- Supports Intel Architecture with Dynamic Execution
- On-die, primary 32 kB instruction cache and 32 kB write-back data cache
- On-die, 2 MB second level cache with Advanced Transfer Cache Architecture
- Data Prefetch Logic
- Streaming SIMD Extensions 2 (SSE2) and Streaming SIMD Extensions 3 (SSE3)
- The Yonah Standard Voltage and Low Voltage processor are offered at 667 MHz FSB
- The Yonah Ultra Low Voltage processor is offered at 533 MHz FSB
- Advanced Power Management features including Enhanced Intel SpeedStep technology
- Digital Thermal Sensor
- Micro-FCPGA and Micro-FCBGA packaging technologies

8224 N/B Maintenance

- Execute Disable Bit support for enhanced security
- Intel Virtualization Technology

1.2.2 Clock Generator

ICS9LPR310 is a low power CK410M-compliant clock specification. This clock synthesizer provides a single chip solution for next generation P4 Intel processors and Intel chipsets. **ICS9LPR310** is driven with a 14.318MHz crystal.

❖ Output Features:

- 2 - 0.7 V differential CPU pairs
- 8 - 0.7 V differential PCIEX pairs
- 1 - 0.7 V differential SATA pair
- 1 - 0.7 V differential LCDCLK/PCIEX selectable pair
- 4 - PCI (33 MHz)
- 2 - PCICLK_F, (33 MHz) free-running
- 1 - USB, 48 MHz
- 1 - DOT 96 MHz/27 MHz selectable pair
- 2 - REF, 14.318 MHz

8224 N/B Maintenance

❖ **Key Specifications:**

- CPU outputs cycle-cycle jitter < 85ps
- PCIEX outputs cycle-cycle jitter < 125ps
- SATA outputs cycle-cycle jitter < 125ps
- PCI outputs cycle-cycle jitter < 500ps
- +/- 300ppm frequency accuracy on CPU, PCIEX and SATA clocks
- +/- 100ppm frequency accuracy on USB clocks

❖ **Features/Benefits:**

- Supports tight ppm accuracy clocks for Serial-ATA and PCIEX
- Supports programmable spread percentage and frequency
- Uses external 14.318 MHz crystal, external crystal load caps are required for frequency tuning

Mitac Secret
Confidential Document

8224 N/B Maintenance

1.2.3 The Mobile Intel 945GM Express Chipset

The Mobile Intel 945GM Express Chipset is designed for use in Intel's next generation mobile platform, code named NAPA.

The Intel 945GM Express Chipset come with the Generation 3.5 Intel Integrated Graphics Engine, and the Intel Graphics Media Accelerator (GMA) 950, providing enhanced graphics support over the previous generation (G)MCH's.

The (G)MCH manages the flow of information between the four following primary interfaces:

- FSB
- System Memory Interface
- Graphics Interface
- DMI

The (G)MCH can also be enabled to support external graphics, using the x16 PCI Express Graphics attach port. When external graphics is enabled, the internal graphics port are inactive.

Features

❖ Processor Support

- All Yonah variants

8224 N/B Maintenance

- Merom support
- 533 MHz and 667MHz Front Side Bus (FSB) support
- Source synchronous double-pumped (2x) Address
- Source synchronous quad-pumped (4x) Data
- Other key features are:
 - Support for DBI (Data Bus Inversion)
 - Support for MSI (Message Signaled Interrupt)
 - 32-bit interface to address up to 4 GB of memory
 - A 12 deep In-Order Queue to pipeline FSB commands
 - GTL+ bus driver with integrated GTL termination resistors

❖ **Memory System**

- Support Single/Dual Channel DDR2 SDRAM
- Maximum Memory supported 2 GB
- 64 bit wide per channel
- Three Memory Channel Configurations supported
 - Single Channel
 - Dual Channel Symmetric

8224 N/B Maintenance

-- Dual Channel Asymmetric

- One SO-DIMM connector per channel
- Support for DDR2 at 400MHz, 533MHz and 667MHz
- 256Mb , 512Mb and 1 Gb Memory Technologies supported
- Support for x8 and x16 devices
- Maximum Memory supported: 2 GB
- Support for DDR2 On-Die Termination (ODT)
- Supports Partial Writes to memory using Data Mask signals (DM)
- Intel Rapid Memory Power Management
- Dynamic row power-down
- No support for Fast Chip Select mode
- Support for 2N timings only

❖ **Discrete Graphics using PCI Express**

- One 16-lane (x16) PCI Express port for external PCI Express Based graphics card
- Fully compliant to the PCI Express Base Specification revision 1.0a. base PCI Express frequency of 2.5 GHz only

8224 N/B Maintenance

- Raw bit-rate on the data pins of 2.5Gb/s, resulting in a real bandwidth per pair of 250 MB/s given the 8/10 encoding used to transmit data across this interface
- Maximum theoretical realized bandwidth on interface of 4 GB/s in each direction simultaneously, for an aggregate of 8 GB/s when x16
- 100 MHz differential reference clock (shared by PCI Express Gfx and DMI)
- STP-AGP/AGP_BUSY Protocol equivalent for PCI Express based attach is via credit based PCI Express mechanism
- PCI Express power management support: L0s, L1, L2/L3 Ready, L3
- Lane# 0 only for signaling and detection of exit from L0s and L1
- Hierarchical PCI-compliant configuration mechanism for downstream devices (i.e., normal PCI 2.2 Configuration space as a PCI-to-PCI Bridge)
- PCI Express Extended Configuration Space. The first 256 bytes of configuration space aliases directly to the PCI Compatibility configuration space. The remaining portion of the fixed 4KB block of memory-mapped space above that (starting at 100h) is known as extended configuration space
- PCI Express Enhanced Addressing Mechanism. Accessing the device configuration space in a flat memory mapped fashion
- Automatic discovery, negotiation, and training of link out of reset
- Supports traditional PCI style traffic (asynchronous snooped, PCI ordering)
- Supports traditional AGP style traffic (asynchronous non-snooped, PCI-X Relaxed ordering)
- Support for peer segment destination write traffic (no peer-to-peer read traffic) in Virtual Channel 0 only

8224 N/B Maintenance

- APIC and MSI interrupt messaging support. Will send Intel-defined “End Of Interrupt” broadcast message when initiated by the CPU
- Support for Isochronous non-snooped traffic through a dedicated Virtual Channel
- Downstream Lock Cycles(including Split Locks)
- Automatic clock extraction and phase correction at the receiver

❖ Internal Graphics

- Intel Gen 3.5 Integrated Graphics Engine
- 250 MHz core render clock at 1.05V core voltage
- Supports TV-Out, LVDS, CRT and SDVO
- Intel Dual Frequency Graphics Technology
- Intel Dynamic Video Memory Technology (DVMT 3.0)
- Intel Smart 2D Display Technology
- Intel Display Power Saving Technology 2.0
- Video Capture via x1 concurrent PCIE port
- Higher Performance MPEG-2 Decoding
- Hardware Acceleration for VLD / iDCT
- 4x pixel rate HWMC

8224 N/B Maintenance

- DX 9.1
- Hardware Motion Compensation
- Intermediate Z in Classic Rendering

❖ **Analog CRT**

- Integrated 400 MHz RAMDAC
- Analog Monitor Support up to QXGA (2048 x 1536)
- Support for CRT Hot Plug

❖ **Dual Channel LVD**

- Panel support up to UXGA (1600 x 1200)
- 25-112 MHz single / dual channel
 - Single channel LVDS interface support: 1 x 18 bpp
 - Dual channels LVDS interface support: 2 x 18 bpp panel support up to UXGA (1600 x 1200)
 - TFT panel type supported
- Pixel Dithering for 18 bit TFT panel to emulate 24 bpp true color displays
- Panel Fitting, Panning, and Center Mode Supported
- CPIS 1.5 compliant

8224 N/B Maintenance

- Spread spectrum clocking supported
- Panel Power Sequencing support
- Integrated PWM interface for LCD backlight inverter control

❖ TV - OUT

- Three integrated 10 bit DACS
- Macro Vision support
- Overscaling
- NTSC / PAL
- Component, S-Video and Composite Output interfaces
- HDTV support
 - Single channel LVDS interface support: 1 x 18 bpp

❖ DMI

- Chip-to-chip interface between (G)MCH and Intel 82801GBM (ICH7M)
- Configurable as x2 or x4 DMI lanes
- 2 GB/s (1 GB/s each direction) point-to-point interface to Intel 82801GBM

8224 N/B Maintenance

- 32 bit downstream address
- Direct Media Interface asynchronously coupled to core
- Supports 3 Virtual Channels for traffic class performance differentiation
- Supports both snooped and non-snooped traffic
- Supports isochronous non-snooped traffic
- Supports legacy snooped isochronous traffic
- Supports the following traffic types to or from Intel 82801GBM
- Peer write traffic between DMI and PCI Express Graphics port
- DMI-to-DRAM
- DMI-to-CPU (FSB Interrupts or MSIs only)
- CPU-to-DMI
- Messaging in both directions, including Intel Vendor-specific messages
- Supports Power Management state change messages
- APIC and MSI interrupt messaging support
- Supports SMI, SCI and SERR error indication
- Legacy support for ISA regime protocol (PHOLD/PHOLDA) required for parallel port DMA, floppy drive, and LPC bus masters

8224 N/B Maintenance

1.2.4 I/O Controller Hub : INTEL ICH7-M

The ICH7 provides extensive I/O support. Functions and capabilities include:

- PCI Express Base Specification, Revision 1.0a support
- PCI Local Bus Specification, Revision 2.3 support for 33 MHz PCI operations (supports up to six Req/Gnt pairs)
- ACPI Power Management Logic Support
- Enhanced DMA controller, interrupt controller, and timer functions
- Integrated Serial ATA host controller with independent DMA operation on four ports and AHCI (ICH7R only) support
- USB host interface with support for eight USB ports; four UHCI host controllers; one EHCI high-speed USB 2.0 Host controller
- Integrated LAN controller
- System Management Bus (SMBus) Specification, Version 2.0 with additional support for I²C devices
- Supports Audio Codec '97, Revision 2.3 Specification (a.k.a , AC '97 Component Specification, Revision 2.3) which provides a link for Audio and Telephony codecs (up to 7 channels)
- Supports Intel High Definition Audio
- Supports Intel Matrix Storage Technology (ICH7R only)
- Supports Intel Active Management Technology

8224 N/B Maintenance

- Low Pin Count (LPC) interface
- Firmware Hub (FWH) interface support
- Serial Peripheral Interface (SPI) support

1.2.5 VGA Controller: ATI M56-P

The M52-P is based on PCI Express technology and leverages a brand new graphics architecture. Based on 90nm micron process technology, the M52-P will deliver a 16-lane PCI Express bus interface and lead-free ASIC.

Features

❖ Processor / Host Bus Support

- Support for Microsoft® DirectX® 9.0 programmable vertex and pixel shaders in hardware.
- Shader model 3.0 vertex and pixel shader support:
- Full speed 32-bit floating point processing
- High dynamic range rendering with floating point blending support
- High performance dynamic branching and flow control
- Complete feature set also supported in OpenGL® 2.0.

8224 N/B Maintenance

❖ **Anti-Aliasing and Anisotropic Filtering**

- 2x/4x/6x Anti-Aliasing modes
- Sparse multi-sample algorithm with gamma correction, programmable sample patterns, and centroid sampling
- Lossless Color Compression (up to 6:1) at all resolutions, including widescreen HDTV resolutions
- Temporal Anti-Aliasing
- 2x/4x/8x/16x Anisotropic Filtering modes
- Up to 128-tap texture filtering
- Adaptive algorithm with performance and quality options

❖ **3Dc+™ — Advanced Texture Compression**

- High quality 4:1 compression for normal maps and luminance maps
- Works with any single-channel or two-channel data format

❖ **Next-Generation HYPER Z™ Technology**

- Hierarchical Z-Buffer with Early Z Test
- Lossless Z-Buffer Compression (up to 48:1)
- Fast Z-Buffer Clear

8224 N/B Maintenance

- Z Cache optimized for real-time shadow rendering
- Optimized for performance at high display resolutions, including widescreen HDTV resolutions

❖ **High Performance Memory Support**

- Support for DDR1 and DDR2 SDRAM/SGRAM, and GDDR3 SDRAM (except M56-P)

❖ **Programmable Video Processing Engine**

- Seamless integration of pixel shaders with video in real time
- FULLSTREAM™ video de-blocking technology for Real, DivX, and WMV9 formats
- VIDEOSOAP™ noise removal filtering for captured video
- MPEG1/2/4 decode and encode acceleration
- DXVA Support
- Hardware Motion Compensation, iDCT, DCT and color space conversion
- All-format DTV/HDTV decoding
- YPrPb component output for direct drive of HDTV displays
- Adaptive Per-Pixel De-Interlacing and Frame Rate Conversion (temporal filtering)
- Dual integrated display controllers

8224 N/B Maintenance

- Dual integrated 10 bit per channel 400 MHz DACs
- Integrated 165 MHz TMDS transmitter (DVI 1.0 / HDMI compliant and HDCP ready)
- Additional external TMDS support for dual-link DVI
- Integrated TV Output support up to 1024x768 resolution

1.2.6 AZALIA AUDIO SYSTEM: ALC880

ALC880 provides 7.1 channels of outputs and multiple stereo inputs, along with flexible mixing, mute and finer gain control functions to provide a complete integrated audio solution for PCs. Also the highest 192KHz sample rate DACs and Realtek proprietary hardware content protection are applicable for DVD Audio, which only implemented in high end consumer electronics, now is achieved by PCs with ALC880 inside. ALC880 is also the one and only High Definition Audio Codec integrating three pairs of stereo ADCs which can support microphone array with AEC (Acoustic Echo Cancellation), BF (Beam Forming) and NS (Noise Suppression) technology simultaneously to significantly improve recording quality for conference call. With this unique feature (3 pairs of Stereo ADCs), ALC880 can perform the ultimate performance of HAD like using S/PDIF to output analog data or multiple recording application.

❖ Features

- High performance DACs with 95dB S/N ratio
- Meets performance requirements for audio on PC2001 systems

8224 N/B Maintenance

- 8 channels of DAC support 16/20/24-bit PCM format for 7.1 audio solution
- 3 stereo ADCs support 16/20-bit PCM format, two for microphone array, one for legacy mixer recording
- Supports 44.1K/48K/96K/192KHz DAC sample rate
- All ADCs support 44.1K/48K/96K sample rate
- Applicable for 4ch/192KHz and 6ch/96KHz DVD-Audio solution
- Up to 4 channels of microphone input are supported for AEC/BF application
- Support Power Off CD function
- Support external PCBEEP input and built in BEEP generator
- PCBEEP Pass-Through when link is in RESET state
- Software selectable 2.5V/3.75V VREFOUT
- Default 6 VREFOUTs are supported, additional 4 VREFOUTs are capable by sharing un-used analog I/O pins
- 2 jack detection pins each supports up to 4 jacks plugging can be detected
- 16/20/24-bit S/PDIF-OUT supports 44.1K/48K/96KHz sample rate
- 16/20/24-bit S/PDIF-IN supports 44.1K/48K/96KHz sample rate
- Optional EPAD (External Amplifier Power Down) is supported
- Power support: Digital: 3.3V; Analog: 3.3V/5.0V
- Power management and enhanced power saving features

8224 N/B Maintenance

- 48-pin LQFP package is compatible with AC'97
- Reserve analog mixer architecture is backward compatible with AC'97
- -64dB ~ +30dB with 1dB resolution of mixer gain to achieve finer volume control
- Impedance sensing capability for each re-tasking jack
- All analog jacks are stereo input and output re-tasking for analog plug & play
- Built in headphone amplifier for each re-tasking jack
- Support external volume knob control
- Support 2 GPIO (General Purpose Input/Output) for customized application
- Hardware content protection for DVD-Audio supporting

1.2.7 MDC: Azalia MDC Modem Card (MDC56AZS2)

❖ **Features**

- AC'97/MC'97 2.2 compliant
- MDC Modem support current sense, whenever the current on the line exceeds approximately 150mA, and should immediately go back on hook
- ITU-T V.92 PCM Upstream and V.90 data rates with auto0fallback to V.34, V.32ter V.32 bis and fallbacks

8224 N/B Maintenance

- Virtual Com port with a through put of up to 460.8Kbps
- V.42 bis/MNP 5 data compression
- FAX: Send and receive rates up to 14.4kbps, V.17, V.29, V.27ter
- Hayes AT Command set
- Supports V.42 error correction and V.44, V.42bis/MNP5 data compression
- FAX capabilities: ITU-T V.17, V.29, V.27ter, V.21 Ch2 and TIA/EIA 578 Class1 FAX
- Modem Support Wake up on Ring

1.2.8 System Flash Memory (BIOS)

- Firmware Hub for Intel® 810, 810E, 815, 815E,815EP, 820, 840, 850 Chipsets
- Flexible Erase Capability
 - Uniform 4 KByte Sectors
 - Uniform 16 KByte overlay blocks for SST49LF002A
 - Uniform 64 KByte overlay blocks for SST49LF004A
 - Top boot block protection
 - 16 KByte for SST49LF002A
 - 64 KByte for SST49LF004A

8224 N/B Maintenance

- Chip-Erase for PP Mode
- Single 3.0-3.6V Read and Write Operations
- Superior Reliability
- Firmware Hub Hardware Interface Mode
 - 5-signal communication interface supporting byte Read and Write
 - 33 MHz clock frequency operation
 - WP# and TBL# pins provide hardware write protect for entire chip and/or top Boot Block
 - Block Locking Register for all blocks
 - Standard SDP Command Set
 - Data# Polling and Toggle Bit for End-of-Write detection
 - 5 GPI pins for system design flexibility
 - 4 ID pins for multi-chip selection

1.2.9 Memory System

- ❖ **128MB, 256MB, 512MB, 1GB (x64) 200-Pin DDR2 SDRAM SODIMMs**
 - JEDEC-standard 200-pin, small-outline, dual in-line memory module (SODIMM)
 - VDD=+1.8V±0.1V, VDDQ=+1.8V±0.1V

8224 N/B Maintenance

- JEDEC standard 1.8V I/O (SSTL_18-compatible)
- Differential data strobe (DQS,DQS#) option
- Four-bit prefetch architecture
- Differential clock input (CK,CK#)
- Command entered on each rising CK edge
- DQS edge-aligned with data for Reads
- DQS center-aligned with data for Writes
- Duplicate output strobe (RDQS) option for x8 configuration
- DLL to align DQ and DQS transitions with CK
- Four internal banks for concurrent operation
- Data mask (DM) for masking write data
- Programmable CAS Latency (CL): 2,3,4 and 5
- Posted CAS additive latency (AL): 0,1,2,3 and 4
- Write latency = Read latency – 1^tCK
- Programmable burst lengths: 4 or 8
- Read burst interrupt supported by another READ
- Write burst interrupt supported by another WRITE

8224 N/B Maintenance

- Adjustable data – output drive strength
- Concurrent auto precharge option is supported
- Auto Refresh (CBS) and Self Refresh Mode
- 64ms, 8,192-cycle refresh
- Off-chip drive (OCD) impedance calibration
- On-die termination (ODT)

1.2.10 GIGALAN – BCM5787

The BCM5787 is a seventh generation 10/100/1000BASE-T Ethernet LAN controller solution for high-performance network applications. The device combines a triple-speed IEEE 802.3 compliant Media Access Controller (MAC) with a triple-speed Ethernet transceiver, 1x PCI-E bus interface, and on-chip buffer memory in a single device. The device is fabricated in a 1.2V CMOS process providing a low-power system solution.

❖ Features

- Integrated 10/100/1000BASE-T transceiver
- Automatic MDI crossover function
- PCI-E v1.0a
- 10/100/1000BASE-T full/half-duplex MAC

8224 N/B Maintenance

- Wake on LAN support meeting the ACPI requirements
- Statistics for SNMP MIB II, Ethernet-like MIB, and Ethernet MIB (802.3z, clause 30)
- Serial EEPROM or serial flash support
- JTAG support
- 196-FBGA package

1.2.11 Keyboard System: Winbond W83L951DG

The Winbond mobile keyboard and embedded controller W83L951D/F architecture consists of a Turbo-8051 core logic controller and surrounded by various components, 2K+256 bytes of RAM, 64K on-chip FLASH, LPC host interface, 13 general purpose I/O port with 24 external interrupt source, 4 timers, 1 serial port, 2 SMBus interface for master mode, 3 PS/2 port, two 8-bits and two 16-bits PWM channels, 2 D-A and 8 A-D converters, 1 Consumer Infrared Communications Receiver, 2 Fan Tachometer , 1 Real Time Clock Generator, and Matrix Interface. The part number with an affix of “G” is the Lead-free package product.

❖ Core logic

- 8-bit Turbo 8052 Microprocessor Code based, Speed up to 24MHz
- 256 bytes Internal RAM
- 64K bytes Embedded Programmable Flash Memory

8224 N/B Maintenance

- 2K bytes External SRAM

❖ **Host interface**

- Software Optional with LPC Interface
- Primary Programmable I/O Address Communication Port in LPC Mode
- Support SERIRQ in LPC Interface
- Support Hardware Fast Gate A20 and KBRST
- Support Port 92h

❖ **SMBus**

- Support 2 SMBus Interface support Master Mode

❖ **Timers**

- Support Four Timer Signal with Three Pre-scalars
- Timer 1 and 2 Share the Same Pre-scalar and are Free-Running Only
- Timer X and Y Have Individual Pre-scalar and Support up to Four Control Modes, Free Running, Pulse Output, Event Counter and Pulse Width Measurement

8224 N/B Maintenance

❖ PWM

- Support Four PWM Channels
- PWM 0 and 1 are 8-bits and Programmable Frequency from 62Hz to 7.5 KHz
- PWM 2 and 3 are 16-bits and Programmable Frequency from 6Hz to 3MHz

❖ Fan Tachometer

- Support two Fan Tachometer Inputs

❖ A/D Converter

- Firmware Programmable Optional with 10-bit or 8-bit Resolution
- Support Eight Channels

❖ D/A Converter

- 8-bit Resolution
- Support Two Channels

Mitac Secret
Confidential Document

8224 N/B Maintenance

❖ PS2

- Support Three Hardware PS2 Channels
- Optional PS2 Clock Inhibit by Hardware or Firmware

❖ Keyboard Controller

- Support 16*8 Keyboard Matrix-scan, Expanding to 18*8 and 20*8

❖ GPIO

- Support 104 Useful GPIO Pins Totally and Bit-addressable to Facility Firmware Coding

❖ FLASH

- Support External On-Board 64K Flash via Matrix Interface (GP0, 1, 3)

❖ CIR

- Support Decoding for the NEC Consumer IR Remote Control Format

Mitac Secret
Confidential Document

8224 N/B Maintenance

❖ RTC

- Real Time Clock Generator with 32.768 KHz Input

❖ ACPI

- Support ACPI Appliance
- Secondary Programmable I/O Address Communication Port in LPC Mode

❖ Package

- 128 Pin QFP and 128 Pin LQFP Package Options

1.2.12 Hard Disk Drive

8224 can support SATA or PATA HDD by equipped different HDD transition board.

❖ SATA HDD

The SATA function in the ICH7 has dual modes of operation to support different operating system conditions. In the case of Native IDE enabled operating systems, the ICH7 has separate PCI functions for serial and parallel ATA (“enhanced mode”). To support legacy operating systems, there is only one PCI function for both the serial and

8224 N/B Maintenance

parallel ATA ports if functionality from both SATA and PATA devices is desired (“combined mode”). SATA interface transfer rates are independent of UDMA mode settings. SATA interface transfer rates will operate at the bus’s maximum speed, regardless of the UDMA mode reported by the SATA device or the system BIOS.

- Up-to 150MB/sec bus speed (Serial ATA Generation 1)
- Compliant with Serial ATA 1.0a Specification and Serial ATA 2 Extensions 1.0
- Supports 48bit-LBA addressing
- Supports Native DMA Queued command (First party DMA queued)
- Also supports Legacy DMA Queued command
- Supports Staggered Spin-Up function
- Supports Hot-Plug features
- Supports Serial ATA power management (Host initiated Partial/Slumber)

❖ IDE HDD

The ICH7 IDE controller features one set of interface signals that can be enabled, tri-stated or driven low. The IDE interfaces of the ICH7 can support several types of data transfers:

- Programmed I/O (PIO): processor is in control of the data transfer
- 8237 style DMA: DMA protocol that resembles the DMA on the ISA bus, although it does not use the 8237 in the ICH7. This protocol off loads the processor from moving data. This allows higher transfer rate of up to 16MB/s
- Ultra ATA/33/66/100: DMA protocol that redefines signals on the IDE cable to allow both host and target throttling of data and transfer rates of up to 33/66/100 MB/s

8224 N/B Maintenance

1.2.13 CIR

The TSOP62.. - series are miniaturized SMD-IR Receiver Modules for infrared remote control systems. PIN diode and preamplifier are assembled on lead frame, the epoxy package is designed as IR filter. The demodulated output signal can directly be decoded by a microprocessor. TSOP62.. is the standard IR remote control SMD-Receiver series, supporting all major transmission codes.

Features

❖ **Photo detector and preamplifier in onepackage**

- Internal filter for PCM frequency
- Continuous data transmission possible
- TTL and CMOS compatibility
- Output active low
- Low power consumption
- High immunity against ambient light
- Low power consumption
- Lead (Pb)-free component
- Component in accordance to RoHS 2002/95/EC and WEEE 2002/96/EC

8224 N/B Maintenance

1.2.14 Card Reader & IEEE 1394 – PCI8402ZHK

The PCI8402 controller is a four-function PCI controller compliant with *PCI Local Bus Specification*, It is 216 ball PBGA package.

Function 0 is a dummy PC Card controller function. The PC Card socket is non-functional and the pins associated with the PC card socket may be left unconnected. The function is required for device enumeration and is provided for BIOS compatibility with existing devices. The PC Card function may be hidden from the OS by the BIOS.

Function 1 of the PCI8402 controller is compatible with IEEE Std 1394a-2000 and the latest *1394 Open Host Controller Interface Specification*. The chip provides the IEEE1394 link and 1-port PHY function and is compatible with data rates of 100, 200, and 400 Mb/s per second. Deep FIFOs are provided to buffer 1394 data and accommodate large host bus latencies. The PCI8402 controller provides physical write posting and a highly tuned physical data path for SBP-2 performance.

Function 2 of the PCI8402 controller is a PCI-based Flash Media controller that supports Memory Stick, Memory Stick-Pro, SmartMedia, xD, SD, and MMC cards. This function controls communication with these Flash Media cards through a dedicated Flash Media socket. In addition, this function includes DMA capabilities for improved Flash Media performance.

Function 3 of the PCI8402 controller is a PCI-based SD host controller that supports MMC, SD, and SDIO cards. This function controls communication with these Flash Media cards through a dedicated Flash Media socket. In addition, this function is compliant with the *SD Host Controller Standard Specification* and includes both DMA capabilities and support for SD suspend/resume.

8224 N/B Maintenance

1.3 Other Functions

1.3.1 Hot Key Function

Keys Combination	Feature	Meaning
Fn + F1	Power down	Mini PCI power down
Fn + F3	Reserve	
Fn + F4	Volume down	
Fn + F5	Volume up	
Fn + F6	LCD/external CRT switching	Rotate display mode in LCD only, CRT only, and simultaneously display
Fn + F7	Brightness down	Decreases the LCD brightness
Fn + F8	Brightness up	Increases the LCD brightness
Fn + F10	Mute	Audio Mute
Fn + F11	Panel Off/On	Toggle Panel on/off
Fn + F12	Suspend to DRAM / HDD	Force the computer into either Suspend to HDD or Suspend to DRAM mode depending on BIOS Setup

1.3.2 Power On/Off/Suspend/Resume Button

1.3.2.1 APM Mode

At APM mode, power button is on/off system power.

8224 N/B Maintenance

1.3.2.2 ACPI Mode

At ACPI mode, Windows power management control panel set power button behavior.

You could set “standby” , “power off” or “hibernate” (must enable hibernate function in power management) to power button function.

Continue pushing power button over 4 seconds will force system off at ACPI mode.

1.3.3 Cover Switch

System automatically provides power saving by monitoring Cover Switch. It will save battery power and prolong the usage time when user closes the notebook cover.

At ACPI mode there are four functions to be chosen at windows power management control panel.

1. None
2. Standby
3. Off
4. Hibernate (must enable hibernate function in power management)

8224 N/B Maintenance

1.3.4 LED Indicators

1.3.4.1 Five LED Indicators at Front Side:

From left to right that indicates POWER, Battery Status, HDD/CD-ROM, NUM LOCK, CAP LOCK, SCROLL LOCK, WLAN.

-- POWER:

This LED lights blue when the notebook was powered by AC or battery power line, Flashes orange (on 1 second, off 1 second) when entered suspend to RAM state . The LED is off when the notebook is in power off state.

-- BATTERY STATUS:

With battery operation, this LED stays off. When the battery charge drops to 10% of capacity, the LED lights red, flashes per 1 second and beeps per 2 second. When AC is connected, this indicator glows blue if the battery pack is fully charged or orange (amber) if the battery is being charged.

System has five status LED indicators at front side which to display system activity. HDD/CD-ROM, NUM LOCK, CAPS LOCK, SCROLL LOCK and WLAN.

8224 N/B Maintenance

1.3.5 Battery Status

1.3.5.1 Battery Warning

System also provides Battery capacity monitoring and gives users a warning signal to alarm them to store data before battery dead. This function also protects system from mal-function while battery capacity is low.

Battery Warning: Capacity below 10%, Battery Capacity LED flashes per second, system beeps per 2 seconds.

System will Suspend to HDD after 2 Minutes to protect users data.

1.3.5.2 Battery Low State

After Battery Warning State, and battery capacity is below 5%, system will generate beep sound for twice per second.

1.3.5.3 Battery Dead State

When the battery voltage level reaches 8.56 volts, system will shut down automatically in order to extend the battery packs' life.

8224 N/B Maintenance

1.3.6 Fan Power on/off Management

FAN is controlled by W83L951DG embedded controller-using ADM1032 to sense CPU temperature and PWM control fan speed. Fan speed is depended on CPU temperature. Higher CPU temperature faster Fan Speed.

1.3.7 CMOS Battery

CR2032 3V 220mAh lithium battery

When AC in or system main battery inside, CMOS battery will consume no power.

AC or main battery not exists, CMOS battery life at less (220mAh/5.8uA) 4 years.

1.3.8 I/O Port

- ❖ One Power Supply Jack
- ❖ One External CRT Connector For CRT Display
- ❖ Supports four USB port for all USB devices
- ❖ One MODEM RJ-11 phone jack for PSTN line
- ❖ One RJ-45 for LAN

8224 N/B Maintenance

- ❖ One IEEE1394 port
- ❖ One S/PDIF Jack.
- ❖ One Microphone Input Jack.
- ❖ One S-Video (PAL/NTSC) connector
- ❖ One Express Card Jack
- ❖ Two MINI PCI-E Jack for WLAN & TV Tuner Card

1.3.9 Battery Current Limit and Learning

Implanted H/W current limit and battery learning circuit to enhance protection of battery.

MITAC Secret
Confidential Document

8224 N/B Maintenance

1.4 Power Management

The 8224 system has built in several power saving modes to prolong the battery usage for mobile purpose. User can enable and configure different degrees of power management modes via ROM CMOS setup (booting by pressing F2 key). Following are the descriptions of the power management modes supported.

1.4.1 System Management Mode

❖ Photo detector and preamplifier in onepackage

- In this mode, each device is running with the maximal speed. CPU clock is up to its maximum.

❖ Doze Mode

- In this mode, CPU will be toggling between on & stop grant mode either. The technology is clock throttling.
- This can save battery power without loosing much computing capability.
- The CPU power consumption and temperature is lower in this mode.

❖ Standby Mode

- For more power saving, it turns of the peripheral components. In this mode, the following is the status of each device:

8224 N/B Maintenance

- CPU: Stop grant
- LCD: backlight off
- HDD: spin down

❖ Suspend to DRAM

- The most chipset of the system is entering power down mode for more power saving. In this mode, the following is the status of each device:

1. Suspend to DRAM

- CPU: off
- Intel 915GM: Partial off
- VGA: Suspend
- PCMCIA: Suspend
- Audio: off
- SDRAM: self refresh

2. Suspend to HDD

- All devices are stopped clock and power-down
- System status is saved in HDD
- All system status will be restored when powered on again

8224 N/B Maintenance

1.4.2 Other Power Management Functions

❖ HDD & Video access

System has the ability to monitor video and hard disk activity. User can enable monitoring function for video and/or hard disk individually. When there is no video and/or hard disk activity, system will enter next PMU state depending on the application. When the VGA activity monitoring is enabled, the performance of the system will have some impact.

MiTac Secret
Confidential Document

8224 N/B Maintenance

1.5 Appendix 1: Intel ICH7-M GPIO Definitions (1)

Pin Name	Current Define	Input/Output	Function	Power Well
GPIO0	PM_BMBUSY#	I/O	BM BUSY	CORE
GPIO1	MINIPCI_ACT#	I/O	MINIPCI in detect	CORE
GPIO2	PCI_INTE#	I/O	PCI interrupt for LAN	CORE
GPIO3	PCI_INTF#	I/O	PCI interrupt for MINIPCI	CORE
GPIO4	PCI_INTG#	I/O	PCI interrupt for IEEE 1394	CORE
GPIO5	PCI_INTH#	I/O	pull high for PCI	CORE
GPIO6	W_DISABLE#	I/O	Wireless LAN disable	CORE
GPIO7	SCI#	I/O	Sytem Control Interrupt	CORE
GPIO8	EXTSMI#	I/O	SMI signal for chipset	RESUME
GPIO9	X	I/O	X	RESUME
GPIO10	X	I/O	X	RESUME
GPIO11	SMBALERT#	I/O	SMBus alert	RESUME
GPIO12	X	I/O	X	RESUME
GPIO13	X	I/O	X	RESUME
GPIO14	X	I/O	X	RESUME
GPIO15	TV_DISABLE#	I/O	TV disable	RESUME
GPIO16	DPRSPLVR	I/O	Deeper Sleep	CORE
GPIO17	X	I/O	X	CORE
GPIO18	STOP_PCI#	I/O	PCI stop	CORE
GPIO19	PANEL_ID1	I/O	Panel ID	CORE
GPIO20	STOP_CPU#	I/O	CPU stop	CORE
GPIO21	PANEL_ID0	I/O	Panel ID	CORE
GPIO22	PCI_REQ4#	I/O	PCI Request	CORE
GPIO23	CRT_IN#	I/O	CRT detect	CORE
GPIO24	X	I/O	X	RESUME
GPIO25	SPK_OFF	I/O	Speak off	RESUME
GPIO26	SB_BT_ON#	I/O	Blue Tooth in detect	RESUME

8224 N/B Maintenance

1.5 Appendix 1: Intel ICH7-M GPIO Definitions (2)

Continue to the previous page

Pin Name	Current Define	Input/Output	Function	Power Well
GPIO27	X	I/O	X	RESUME
GPIO28	X	I/O	X	RESUME
GPIO29	X	I/O	X	RESUME
GPIO30	X	I/O	X	RESUME
GPIO31	X	I/O	X	RESUME
GPIO32	PCLKRUN#	I/O	Clock run	CORE
GPIO33	WIRELESS_PD#	I/O	Wireless power down	CORE
GPIO34	LAN_ENABLE#	I/O	LAN enable	CORE
GPIO35	X	I/O	X	CORE
GPIO36	PANEL_ID2	I/O	Panel ID	CORE
GPIO37	X	I/O	X	CORE
GPIO38	MB_ID0	I/O	Mother Board ID	CORE
GPIO39	MB_ID1	I/O	Mother Board ID	CORE
GPIO48	X	I/O	X	CORE
GPIO49	HPWRGD	I/O	CPU power good	V_CPU_IO

8224 N/B Maintenance

1.6 Appendix 2: W83L951DG GPIO Pins Definitions (1)

Pin Name	Pin No.	915 Pin Definitions	I/O	Hi/Low	Function
Port 0					
GP00	94	KB OUT 0	O		Key matrix scan output 0
GP01	93	KB OUT 1	O		Key matrix scan output 1
GP02	92	KB OUT 2	O		Key matrix scan output 2
GP03	91	KB OUT 3	O		Key matrix scan output 3
GP04	90	KB OUT 4	O		Key matrix scan output 4
GP05	89	KB OUT 5	O		Key matrix scan output 5
GP06	88	KB OUT 6	O		Key matrix scan output 6
GP07	87	KB OUT 7	O		Key matrix scan output 7
Port 1					
GP10	86	KB OUT 8	O		Key matrix scan output 8
GP11	85	KB OUT 9	O		Key matrix scan output 9
GP12	84	KB OUT 10	O		Key matrix scan output 10
GP13	83	KB OUT 11	O		Key matrix scan output 11
GP14	82	KB OUT 12	O		Key matrix scan output 12
GP15	81	KB OUT 13	O		Key matrix scan output 13
GP16	80	KB OUT 14	O		Key matrix scan output 14
GP17	79	KB OUT 15	O		Key matrix scan output 15
Port 2					
GP20	77	MALL_KEY	I		MALL quick key
GP21	76	IE_KEY	I		IE quick key
GP22	75		I		
GP23	74		I		
GP24/PWM0	73	KBC_BEEP			KBC beep
GP25/PWM1	72				
GP26/PWM2	71	FAN#	O		Fan power PWM control

8224 N/B Maintenance

1.6 Appendix 2: W83L951DG GPIO Pins Definitions (2)

Continue to the previous page

Pin Name	Pin No.	915 Pin Definitions	I/O	Hi/Low	Function
GP27/PWM3	70		O		
Port 3					
GP30	102	KEY IN 0	I	Pull High	Key matrix input 0
GP31	101	KEY IN 1	I	Pull High	Key matrix input 1
GP32	100	KEY IN 2	I	Pull High	Key matrix input 2
GP33	99	KEY IN 3	I	Pull High	Key matrix input 3
GP34	98	KEY IN 4	I	Pull High	Key matrix input 4
GP35	97	KEY IN 5	I	Pull High	Key matrix input 5
GP36	96	KEY IN 6	I	Pull High	Key matrix input 6
GP37	95	KEY IN 7	I	Pull High	Key matrix input 7
Port 4					
GP40/FAN_TACH0	68	FAN_SPEED	I		Fan speed input
GP41/FAN_TACH1	67				
GP42/RXD	66	KBC_RX	I		For firmware debug (请留焊点)
GP43/TXD	65	KBC_TX	O		For firmware debug (请留焊点)
GP44/KBRST#	64	HRCIN#	O		CPU Reset
GP45/GATE_A20	63	A20GATE	O		System A20 Gate
GP46/CLKRUN#	62	PCLKRUN#			LPC Clock Run
GP47/LPCPD#	61	LPCPD			LPC Power-Down
Port 5					
GP50	121	EXTSMI#	O		External SMI#
GP51	120	H8_SCI			Need invert to SCI# sending to SouthBridge
GP52	119	H8_WAKE_IP#	O		Wake-up SouthBridge at ACPI mode
GP53	118	H8_THRM#	O		Thermal throttling control to SouthBridge
GP54	117		O		

8224 N/B Maintenance

1.6 Appendix 2: W83L951DG GPIO Pins Definitions (3)

Continue to the previous page

Pin Name	Pin No.	915 Pin Definitions	I/O	Hi/Low	Function
GP55	116				
GP56/DA0	114	BLADJ	O		Backlight inverter brightness adjust
GP57/DA1	113	I_CTRL	O		Charging current adjust
Port 6					
GP60/AD0	111	BAT_VOLT	I		Battery voltage measure
GP61/AD1	110	I_LIMIT	I		I-Limit function
GP62/AD2	109	PWRGD	I		Monitor system on/off state
GP63/AD3	108	Vtt	I		System Vtt voltage
GP64/AD4	107	BAT_TEMP	I		Battery thermister temperature
GP65/AD5	106		I		
GP66/AD6	105		I		
GP67/AD7	104		I		
Port 7					
GP70/PS2_1CLK	48	T_CLK	I/O	Pull High +5V	TouchPAD Clock
GP71/PS2_1DAT	47	T_DATA	I/O	Pull High +5V	TouchPAD Data
GP72/PS2_2CLK	46				
GP73/PS2_2DAT	45	PWROK	O		Power OK
GP74/PS2_3CLK	44	SUSB_VGA_C	O		SUSB VGA Power
GP75/PS2_3DAT	43	SUSB0.9V	O		SUSC 0.9V
GP76/SDA0	42	BAT_DATA	I/O	Pull High +5V	SMBus Data
GP77/SCL0	41	BAT_CLK	I/O	Pull High +5V	SMBus Clock
Port 8					
GP80/SDA1	40	H8_THRM_DATA			Reserve for SMBus Data
GP81/SCL1	39	H9_THRM_CLK			Reserve for SMBus Clock
GP82/CNTR0	38				Reserve for Fan0 Speed detect

8224 N/B Maintenance

1.6 Appendix 2: W83L951DG GPIO Pins Definitions (4)

Continue to the previous page

Pin Name	Pin No.	915 Pin Definitions	I/O	Hi/Low	Function
GP83/CNTR1	37				Reserve for Fan1 Speed detect
GP84/CIR_RX	36	CIR_RX	I		CIR Receiver
GP85	35	LEARNING	O		Auto-Learning
GP86	34	CHARGING	O		Battery charge control
GP87	33	H8_ENABKL	O		Enable Backlight
Port 9					
GP90	31	KBC_PWRON_VDD3S	O		Turn on VDD3.3 and VDD1.5
GP91	30	H8_RSMRST	O		SouthBridge RSMRST#
GP92	29	ICH_PWRBTN#	O		SouthBridge power button
GP93	28	SUSB1.5V	O		SUSB 1.5V
GP94	27	SUSB1.8V	O		SUSC 1.8V
GP95	26	SW_VDD3	O		VDD3 power source switch
GP96	25	SUSB_VCC_CORE	O		SUSB VCC CORE
GP97	24	SUSB1.8V	O		SUSB 1.8V
Port A					
GPA0/EXTINT10	22	DCON5V	O		DC ON 5V
GPA1/EXTINT11	21	DCON3V	O		DC ON 3V
GPA2/EXTINT12	20	SUSB2.5V	O		SUSB 2.5V
GPA3/EXTINT13	19	SUSB_VCCP	O		SUSB 1.05V
GPA4/EXTINT14	18	SUSB3V	O		SUSB 3V
GPA5/EXTINT15	17	SUSB5V	O		SUSB 5V
GPA6/EXTINT16	16	SUSC1.2V	O		SUSC 1.2V
GPA7/EXTINT17	15	SUSB1.2V	O		SUSB 1.2V
Port B					
GPB0/EXTINT20	14	CAP#	O		Capitals Lock LED indicator

8224 N/B Maintenance

1.6 Appendix 2: W83L951DG GPIO Pins Definitions (5)

Continue to the previous page

Pin Name	Pin No.	915 Pin Definitions	I/O	Hi/Low	Function
GPB1/EXTINT21	13	NUM#	O		Numeral Lock LED indicator
GPB2/EXTINT22	12	SCROLL#	O		Scroll Lock LED indicator
GPB3/EXTINT23	11	BATT_R#	O		Battery Charger Red LED indicator
GPB4/EXTINT24	10	BATT_G#	O		Battery Charger Green LED indicator
GPB5/EXTINT25	9				
GPB6/EXTINT26	8	AC_BATT_POWER#	O		Power LED indicator
GPB7/EXTINT27	7				
Port C					
GPC0/EXTINT30	6	PWRBTN#	I	Pull High	Power Button
GPC1/EXTINT31	5	H8_SUSB#	I		Invert from SUSA# to wake up KBC when system resumed by MDC modem and internal LAN. Inform system power management status.
GPC2/EXTINT32	4	SUSC#	I		System to S4 (soft off) or S5
GPC3/EXTINT33	3	ADEN#	I		AC adapter in detect
GPC4/EXTINT34	2	BATT_DEAD#	I		Battery low detect
GPC5/EXTINT35	1	H8_LIDSW#	I		Cover switch
GPC6/EXTINT36	128	INSTAND_KEY	I		INSTAND quick key
GPC7/EXTINT37	127	CIR_RX	I		CIR RX

8224 N/B Maintenance

2. System View and Disassembly

2.1 System View

2.1.1 Front View

- ❶ Microphone Jack
- ❷ Line In Jack
- ❸ SPDIF Jack
- ❹ Blue Tooth

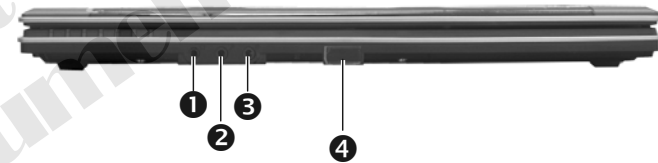

2.1.2 Left-side View

- ❶ CRT Connector
- ❷ IEEE1394 Port
- ❸ Ventilation Openings
- ❹ BTWIRE Switch
- ❺ TV-out Connector
- ❻ RJ45/RJ11 Connector
- ❼ USB Port
- ❽ CardReader Socket
- ❾ New Card Socket

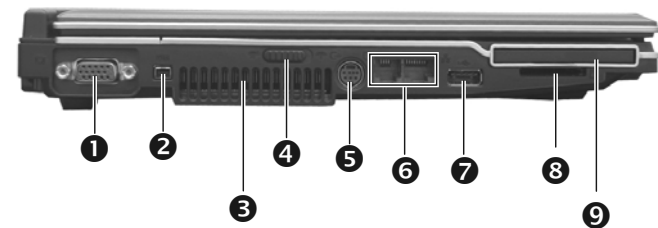

8224 N/B Maintenance

2.1.3 Right-side View

- ❶ DVD-ROM Drive
- ❷ USB Port
- ❸ Power Connector



2.1.4 Rear View

- ❶ TV antenna Connector
- ❷ USB Ports *2
- ❸ Kensington Lock
- ❹ DVI Connector



MiTac Secret
Confidential Document

8224 N/B Maintenance

2.1.5 Bottom View

- ❶ Hard Disk Drive
- ❷ DDR/CPU/Wireless LAN Card/TV Card
- ❸ Battery Park

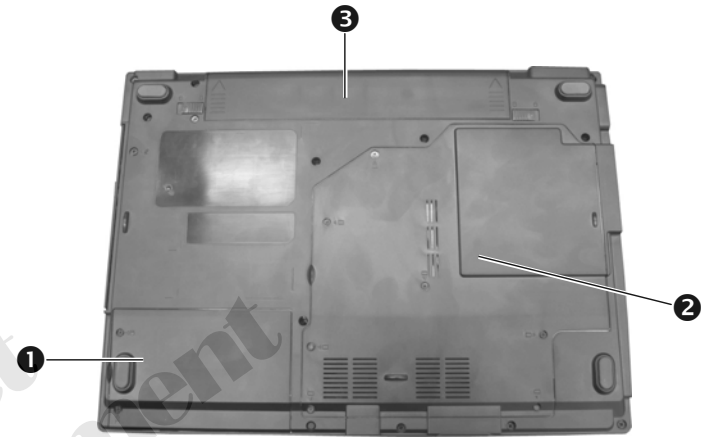

2.1.6 Top-open View

- ❶ LCD Screen
- ❷ Speaker Set
- ❸ Instand/Mail/P1 Key
- ❹ Keyboard
- ❺ Device LED Indicators
- ❻ Touch Pad
- ❼ Power Button

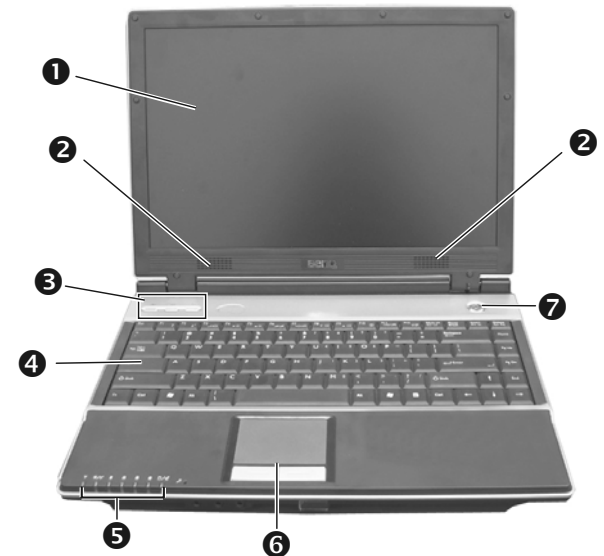

8224 N/B Maintenance

2.2 Tools Introduction

1. Minus screw driver with bit size 2 mm and 1.5 mm for notebook assembly & disassembly.

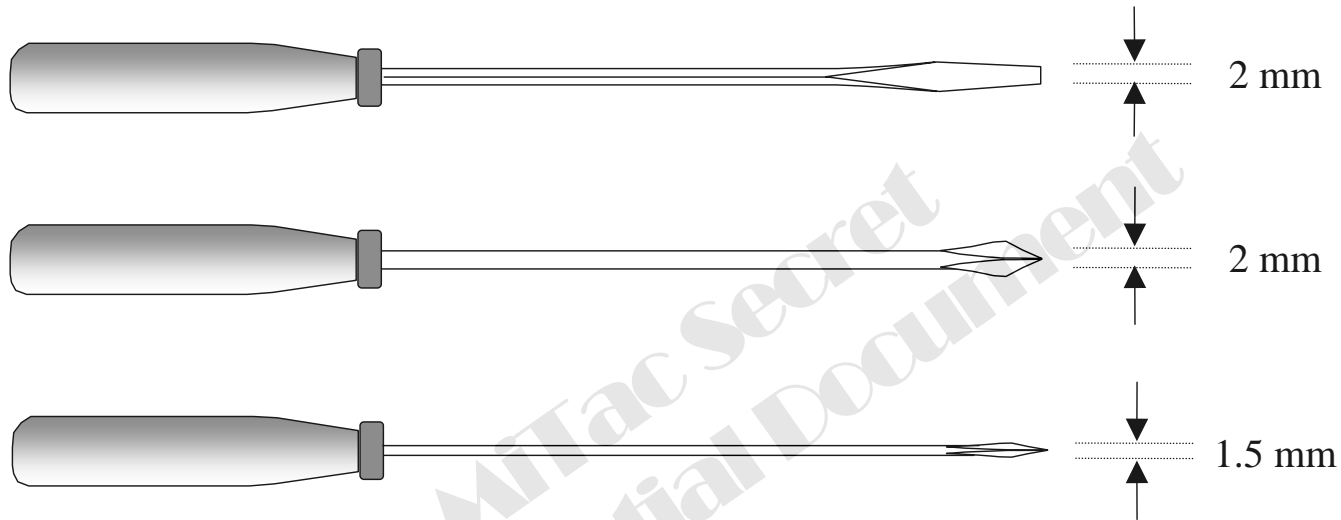

2. Auto screw driver for notebook assembly & disassembly.

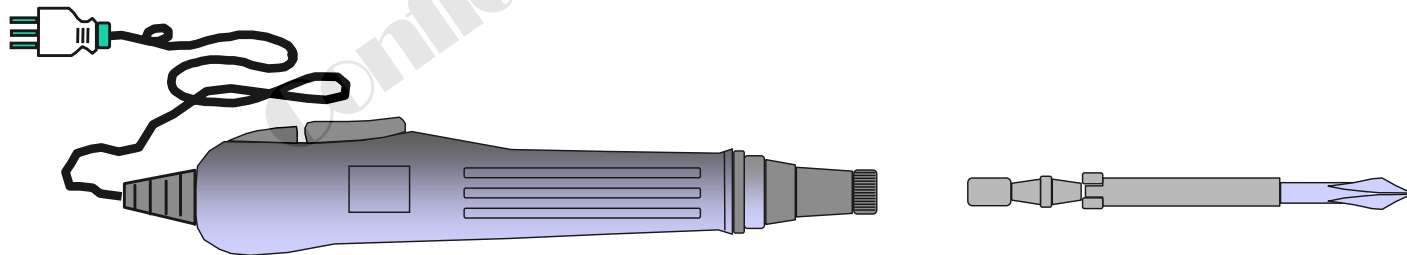

Bit Size

#0

Screw Size	Tooling	Tor.	Bit Size
1. M2.0	Auto-Screw driver	2.0-2.5 kg/cm ²	#0

8224 N/B Maintenance

2.3 System Disassembly

The section discusses at length each major component for disassembly/reassembly and show corresponding illustrations. Use the chart below to determine the disassembly sequence for removing components from the notebook.

***NOTE:** Before you start to install/replace these modules, disconnect all peripheral devices and make sure the notebook is not turned on or connected to AC power.*

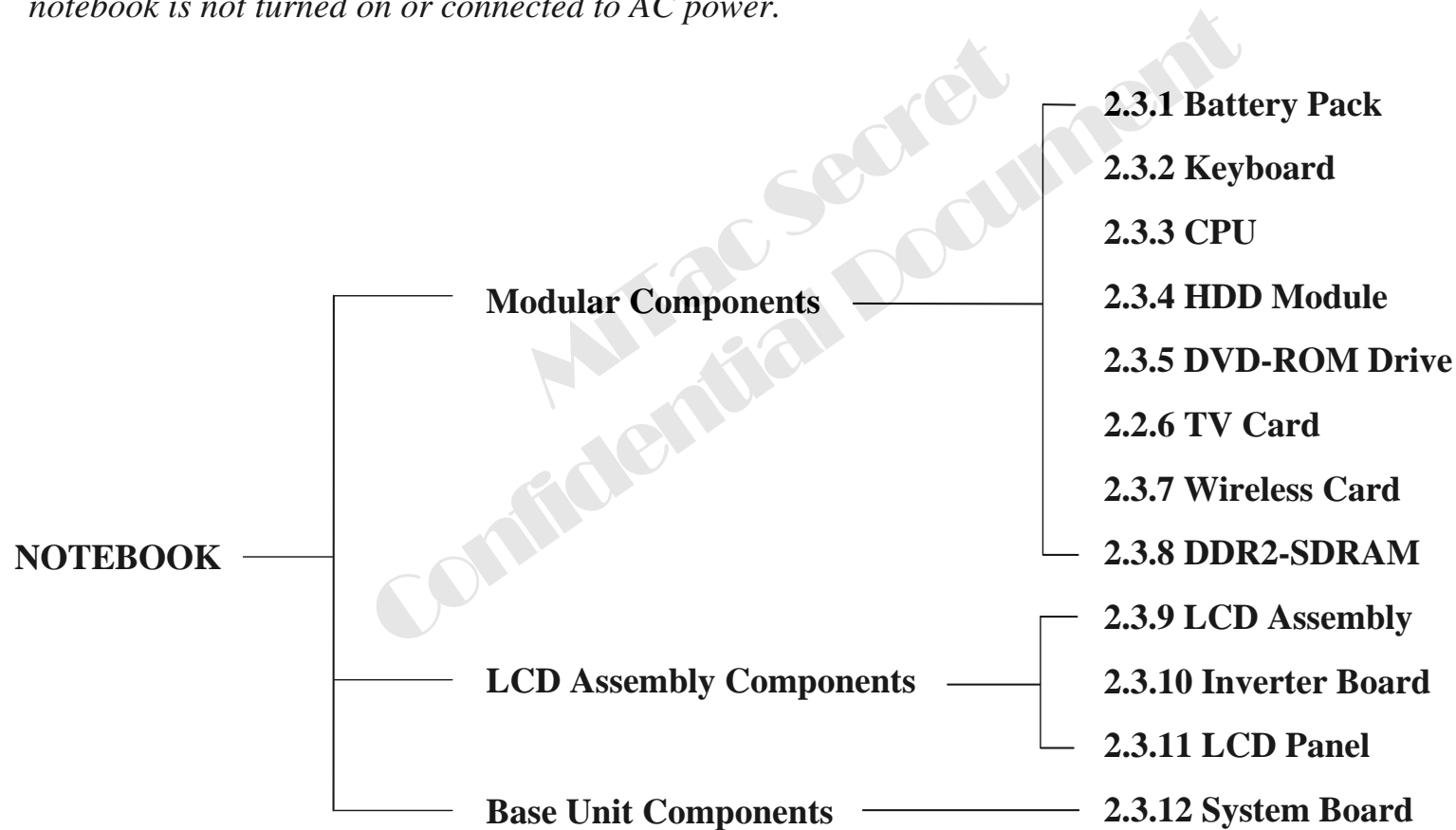

8224 N/B Maintenance

2.3.1 Battery Pack

Disassembly

1. Carefully put the notebook upside down.
2. Slide the two release lever outwards to the “unlock” (☐) position (❶), while take the battery pack out of the compartment (❷). (Figure 2-1)

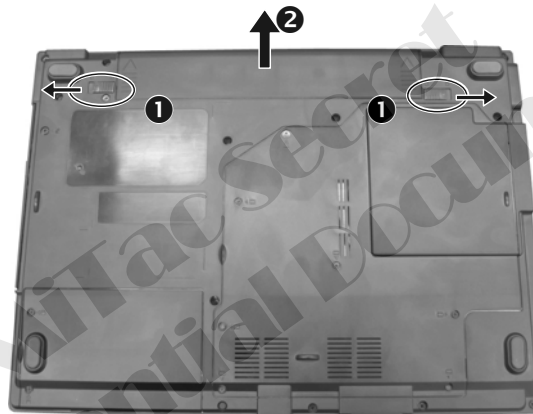

Figure 2-1 Remove the battery pack

Reassembly

1. Replace the battery pack into the compartment. The battery pack should be correctly connected when you hear a clicking sound.
2. Slide the release lever to the “lock” (☒) position.

8224 N/B Maintenance

2.3.2 Keyboard

Disassembly

1. Remove the battery pack. (Refer to section 2.3.1 Disassembly)
2. Remove the eight screws fastening the keyboard cover. (Figure 2-2)
3. Lift the keyboard cover up. (Figure 2-3)

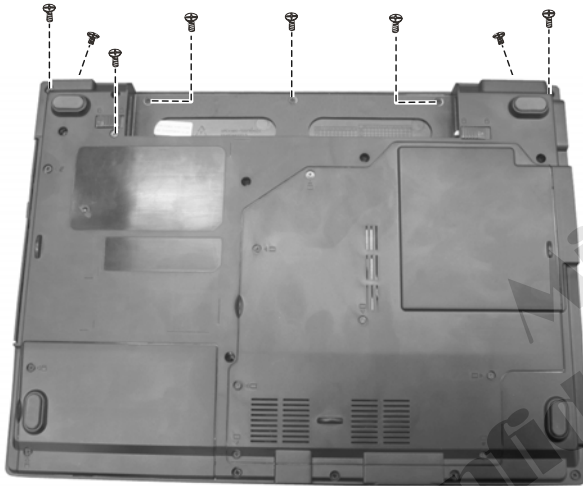

Figure 2-2 Remove the eight screws



Figure 2-3 Lift the keyboard cover

8224 N/B Maintenance

4. Slightly lift up the keyboard, then disconnect the cable from the system board, then separate the keyboard.
(Figure 2-4)



Figure 2-4 Lift the keyboard

Reassembly

1. Reconnect the keyboard cable and fit the keyboard back into place.
2. Replace the keyboard cover and secure with nine screws.
3. Replace the battery pack. (Refer to section 2.3.1 Reassembly)

8224 N/B Maintenance

2.3.3 CPU

Disassembly

1. Remove the battery pack. (Refer to section 2.3.1 Disassembly)
2. Remove the seven screws fastening the CPU cover. (Figure 2-5)
3. Remove the six spring screws that secure the heatsink upon the CPU and disconnect the fan's power cord from system board. (Figure 2-6)

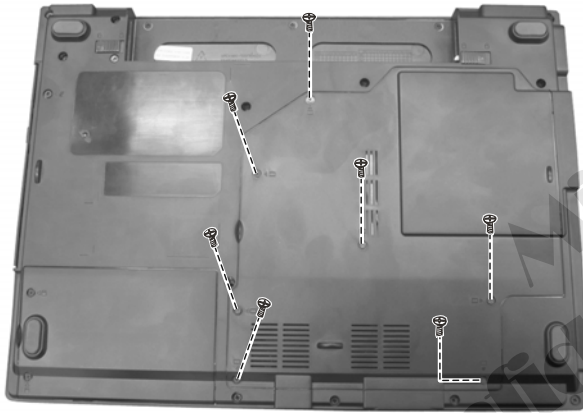

Figure 2-5 Remove the seven screws

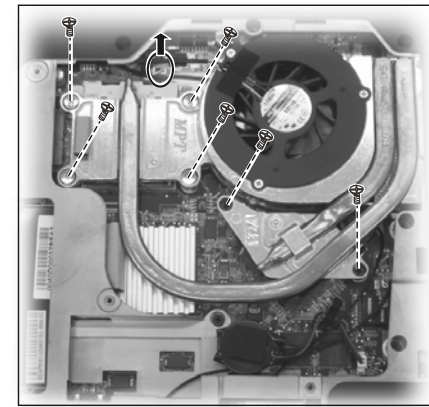

Figure 2-6 Free the heatsink

8224 N/B Maintenance

4. To remove the existing CPU, loosen the screw by a flat screwdriver, upraise the CPU socket to unlock the CPU. (Figure 2-7)

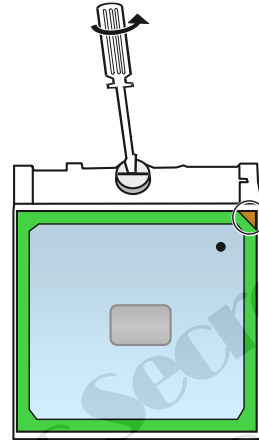

Figure 2-7 Remove the CPU

Reassembly

1. Carefully, align the arrowhead corner of the CPU with the beveled corner of the socket, then insert CPU pins into the holes. Tighten the screw by a flat screwdriver to locking the CPU.
2. Connect the fan's power cord to the system board, fit the heatsink upon the CPU and secure with six spring screws.
3. Replace the CPU cover and secure with seven screws.
4. Replace the battery pack. (Refer to section 2.3.1 Reassembly)

8224 N/B Maintenance

2.3.4 HDD Module

Disassembly

1. Carefully put the notebook upside down. Remove the battery pack. (Refer to section 2.3.1 Disassembly)
2. Remove the two screws fastening the HDD compartment cover. (Figure 2-8)
3. Remove one screw and slide the HDD module out of the compartment. (Figure 2-9)

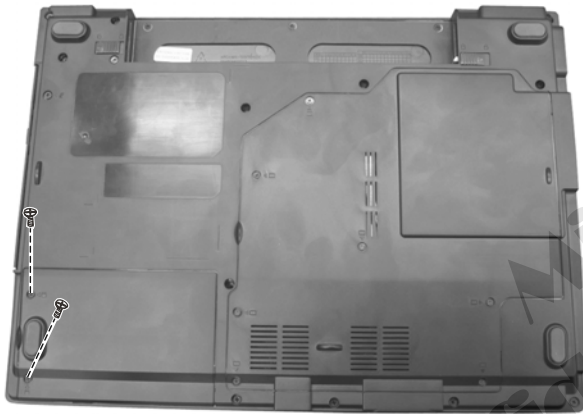

Figure 2-8 Remove the HDD compartment cover

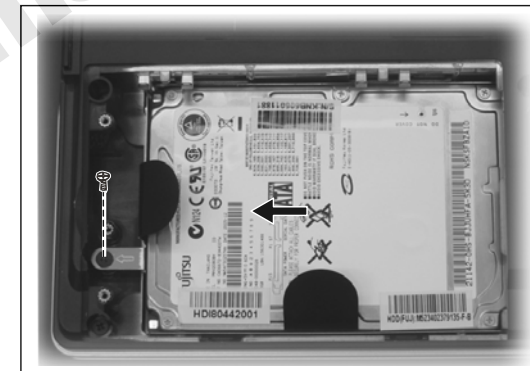

Figure 2-9 Remove HDD module

8224 N/B Maintenance

4. Remove the four screws to separate the hard disk drive from the bracket, remove the hard disk drive. (Figure 2-10)



Figure 2-10 Remove hard disk drive

Reassembly

1. Attach the bracket to hard disk drive and secure with four screws.
2. Slide the HDD module into the compartment and secure with one screw.
3. Replace the HDD compartment cover and secure with two screws.
4. Replace the battery pack. (Refer to section 2.3.1 Reassembly)

8224 N/B Maintenance

2.3.5 DVD-ROM Drive

Disassembly

1. Carefully put the notebook upside down. Remove the battery pack. (Refer to section 2.3.1 Disassembly)
2. Remove the one screw fastening the DVD-ROM drive. (Figure 2-11)
3. Insert a small rod, such as a straightened paper clip, into DVD-ROM drive's manual eject hole (❶) and push firmly to release the tray. Then gently pull out the DVD-ROM drive by holding the tray that pops out (❷). (Figure 2-11)

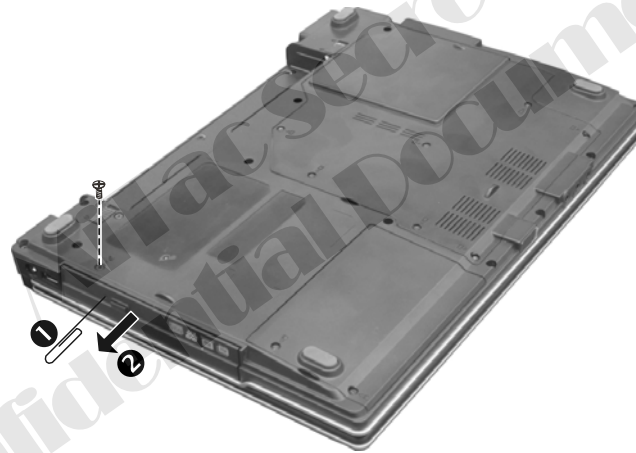

Figure 2-11 Remove the CD/DVD-ROM drive

Reassembly

1. Push the DVD-ROM drive into the compartment and secure with one screw.
2. Replace the battery pack. (Refer to section 2.3.1 Reassembly)

8224 N/B Maintenance

2.3.6 TV Card

Disassembly

1. Carefully put the notebook upside down. Remove the battery pack. (Refer to section 2.3.1 Disassembly)
2. Remove seven screws fastening the CPU cover. (Refer to step 2 of section 2.3.3 Disassembly)
3. Disconnect the TV card's antennae first (❶). Then pull up the TV card (❷) and remove the TV card (❸). (Figure 2-12)

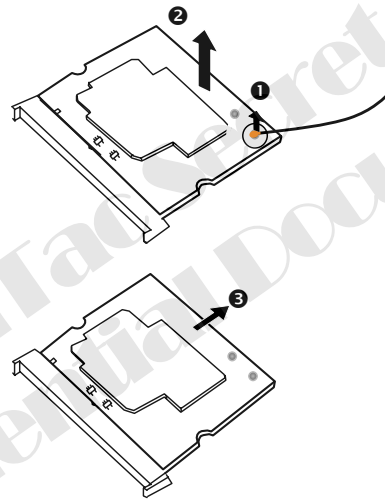

Figure 2-12 Remove the TV card

Reassembly

1. To install the TV card, match the TV card's notched part with the socket's projected part and firmly insert it into the socket. Then push down the TV card into position. Then make sure the antennae fully populated.
2. Replace seven screws to fasten the CPU cover. (Refer to step 3 of section 2.3.3 Reassembly)
3. Replace the battery pack. (Refer to section 2.3.1 Reassembly)

8224 N/B Maintenance

2.3.7 Wireless Card

Disassembly

1. Carefully put the notebook upside down. Remove the battery pack. (Refer to section 2.3.1 Disassembly)
2. Remove seven screws fastening the CPU cover. (Refer to step 2 of section 2.3.3 Disassembly)
3. Disconnect the wireless card's antennae first (❶). Then pull up the wireless card (❷) and remove the wireless card (❸). (Figure 2-13)

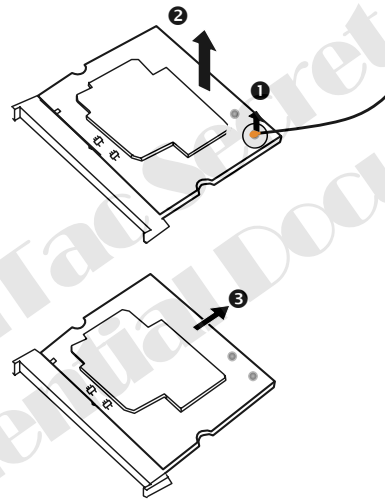

Figure 2-13 Remove the wireless card

Reassembly

1. To install the wireless card, match the wireless card's notched part with the socket's projected part and firmly insert it into the socket. Then push down the wireless card into position. Then make sure the antennae are fully populated.
2. Replace seven screws to fasten the CPU cover. (Refer to step 3 of section 2.3.3 Reassembly)
3. Replace the battery pack. (Refer to section 2.3.1 Reassembly)

8224 N/B Maintenance

2.3.8 DDR2-SDRAM

Disassembly

1. Carefully put the notebook upside down. Remove the battery pack. (See section 2.3.1 Disassembly)
2. Remove seven screws fastening the CPU cover. (Refer to step 2 of section 2.3.3 Disassembly)
3. Pull the retaining clips outwards (❶) and remove two SO-DIMM (❷). (Figure 2-14)

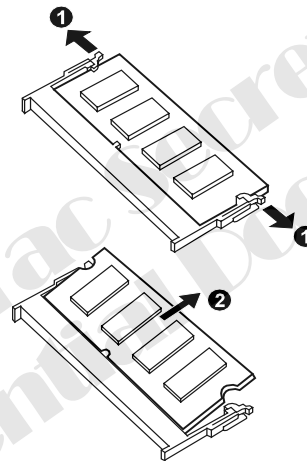

Figure 2-14 Remove the SO-DIMM

Reassembly

1. To install the DDR2, match the DDR2's notched part with the socket's projected part and firmly insert the SO-DIMM into the socket at 20-degree angle. Then push down until the retaining clips lock the DDR2 into position.
2. Replace seven screws to fasten the CPU cover. (Refer to step 3 of section 2.3.3 Reassembly)
3. Replace the battery pack. (See section 2.3.1 Reassembly)

8224 N/B Maintenance

2.3.9 LCD Assembly

Disassembly

1. Remove the battery pack, keyboard, wireless card. (See sections 2.3.1, 2.3.2, and 2.3.7 Disassembly)
2. Remove five screws that secure the hinge and disconnect three cables. (Figure 2-15)
3. Carefully pull the antenna out. Now you can lift up the LCD assembly from base unit.

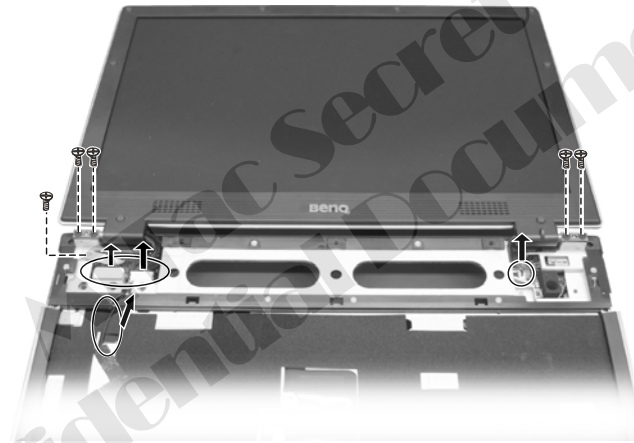

Figure 2-15 Free the LCD ASSY

Reassembly

1. Attach the LCD assembly to the base unit and secure with five screws.
2. Reconnect the three cables to the system board.
3. Replace the wireless card, keyboard and battery pack. (Refer to sections 2.3.7, 2.3.2 and 2.3.1 Reassembly)

8224 N/B Maintenance

2.3.10 Inverter Board

Disassembly

1. Remove the battery, keyboard, wireless card, LCD assembly. (Refer to section 2.3.1, 2.3.2, 2.3.7 and 2.3.9 Disassembly)
2. Remove the two rubber pads and two screws on the corners of the panel. (Figure 2-16)
3. Insert a flat screwdriver to the lower part of the LCD cover and gently pry the frame out. Repeat the process until the cover is completely separated from the housing.
4. Remove the two screws and disconnect the two cables to free the inverter board. (Figure 2-17)

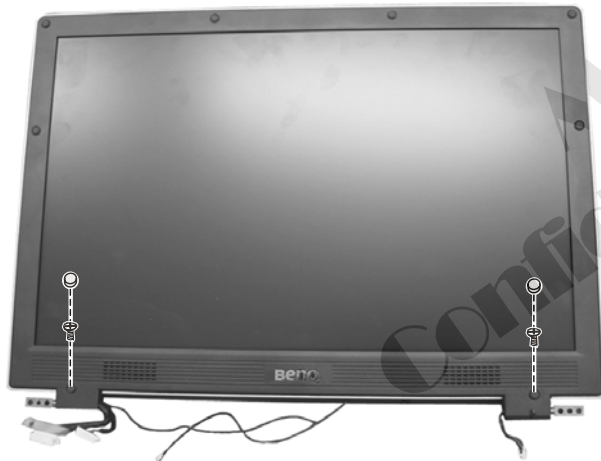

Figure 2-16 Remove LCD cover

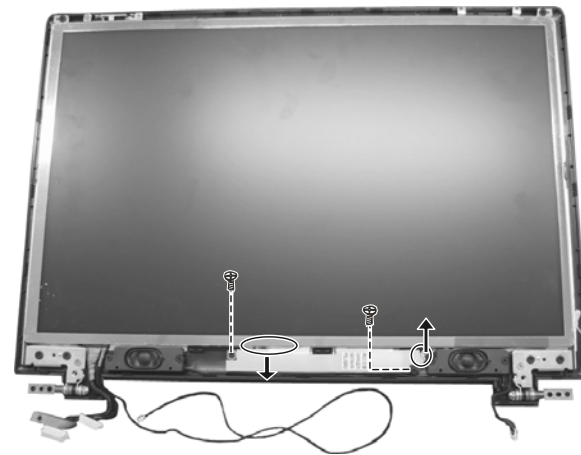

Figure 2-17 Remove the two screws and disconnect the two cables

8224 N/B Maintenance

Reassembly

1. Reconnect two cables. Fit the inverter board back into place and secure with two screws.
2. Fit the LCD cover and secure with two screws and rubber pads.
3. Replace the LCD assembly, wireless card, keyboard and battery pack. (Refer to sections 2.3.9, 2.3.7, 2.3.2 and 2.3.1 Reassembly)

MiTac Secret
Confidential Document

8224 N/B Maintenance

2.3.11 LCD Panel

Disassembly

1. Remove the battery, keyboard, wireless card, LCD assembly and inverter board. (Refer to section 2.3.1, 2.3.2, 2.3.7, 2.3.9 and 2.3.10 Disassembly)
2. Remove six screws. (Figure 2-18)
3. Remove eight screws that secure the LCD bracket. (Figure 2-19)



Figure 2-18 Remove six screws



Figure 2-19 Remove eight screws

8224 N/B Maintenance

4. Disconnect the cable to free the LCD panel. (Figure 2-20)

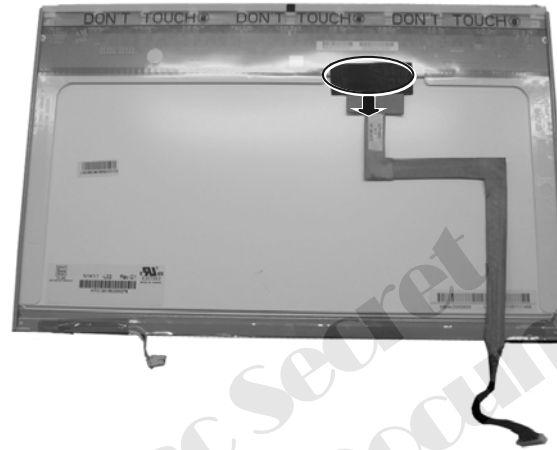

Figure 2-20 Disconnect the cable

Reassembly

1. Replace the cable to the LCD.
2. Attach the LCD panel's bracket back to LCD panel and secure with eight screws.
3. Replace the LCD panel into LCD housing, fasten the LCD panel by six screws.
4. Replace the inverter board, LCD assembly, wireless card, keyboard, battery pack. (See sections 2.3.10, 2.3.9, 2.3.7, 2.3.2 and 2.3.1 Reassembly)

8224 N/B Maintenance

2.3.12 System Board

Disassembly

1. Remove the battery pack, keyboard, CPU, HDD, DVD-ROM, TV card, wireless card, DDR2 and LCD assembly. (Refer to sections 2.3.1 ~ 2.3.9 Disassembly)
2. Disconnect the cable. (Figure 2-21)
3. Carefully put the notebook upside down, remove the sixteen screws fastening the housing and four hex nuts fastening the housing. (Figure 2-22)

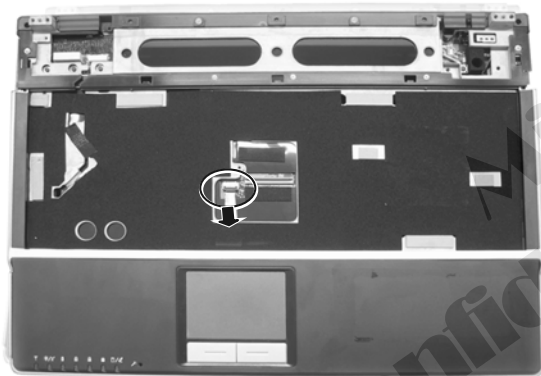

Figure 2-21 disconnect the cable

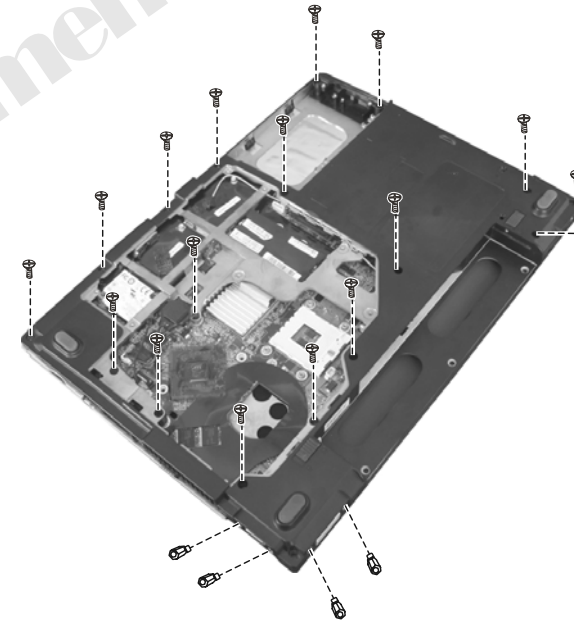

Figure 2-22 Remove the sixteen screws and four hex nuts

8224 N/B Maintenance

4. Remove the two screws and free the top cover. (Figure 2-23)
5. Carefully put the system board upside down and remove one screw. Then separate the bracket, now you can separate the daughter board from system board. (Figure 2-24)

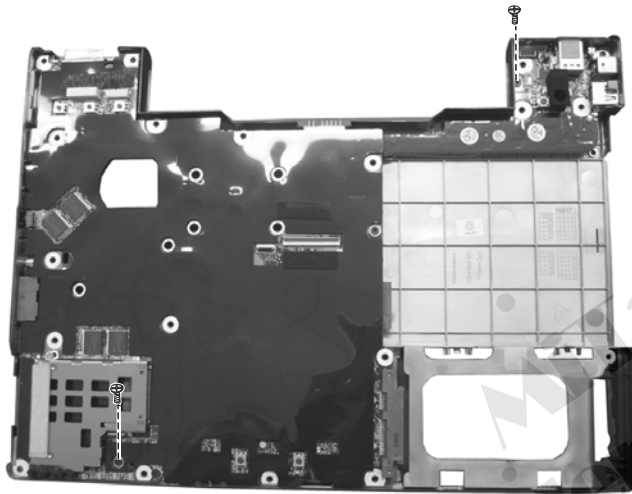

Figure 2-23 Remove the two screws

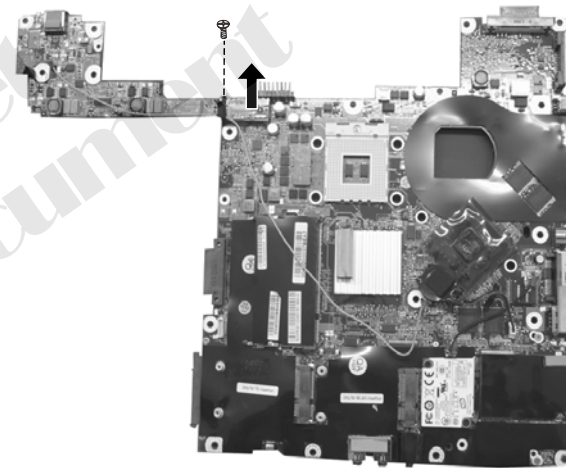

Figure 2-24 Free the daughter board

8224 N/B Maintenance

6. Remove two screws and disconnect the cable, now you can separate the modem board from system board and free the system board. (Figure 2-25)

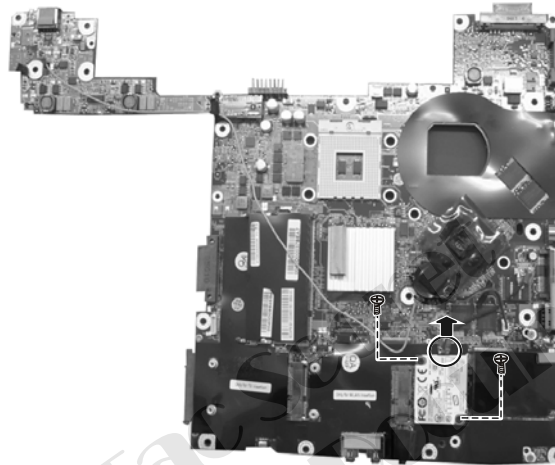

Figure 2-25 Free the system board

Reassembly

1. Replace the modem board to the system board.
2. Replace the daughter board to the system board.
3. Replace the system board back into the housing and secure with two screws.
4. Replace the top cover into the housing and reconnect the touch pad's cable.
5. Secure with sixteen screws and four hex nuts fasten the housing.
6. Replace the LCD assembly, DDR2, Wireless Card, TV card, DVD-ROM, HDD, CPU, keyboard and battery pack. (Refer to previous section reassembly)

8224 N/B Maintenance

3. Definition & Location of Connectors/Switches

3.1 Mother Board-A (1)

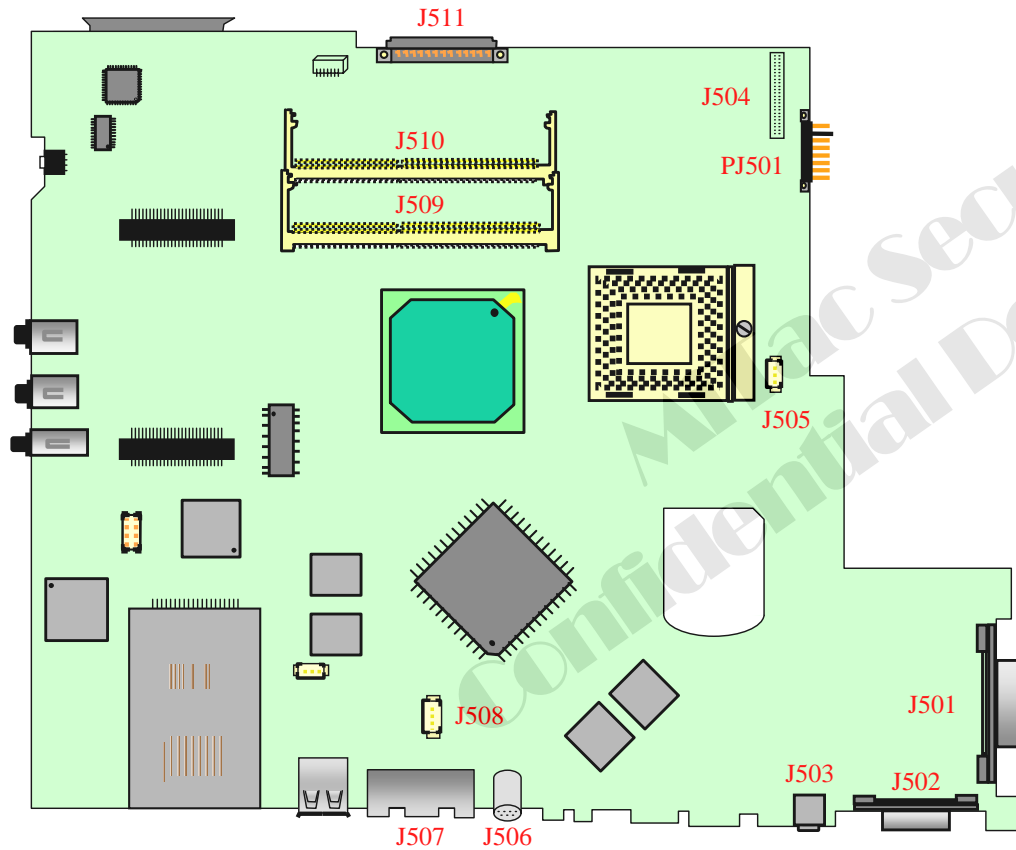

- ✦ PJ501: Battery Connector
- ✦ J501: CRT Connector
- ✦ J502: DVI Connector
- ✦ J503: IEEE 1394 Connector
- ✦ J504: Board to Board Connector
- ✦ J505: CPU Fan Connector
- ✦ J506: TV-Out Connector
- ✦ J507: RJ45/RJ11 Connector
- ✦ J508: RJ45 Jump Wire Connector
- ✦ J509, J510: Extend DDR2 SDRAM Socket
- ✦ J511: Secondary IDE Connector

----- To next page -----

8224 N/B Maintenance

3. Definition & Location of Connectors/Switches

3.1 Mother Board-A (2)

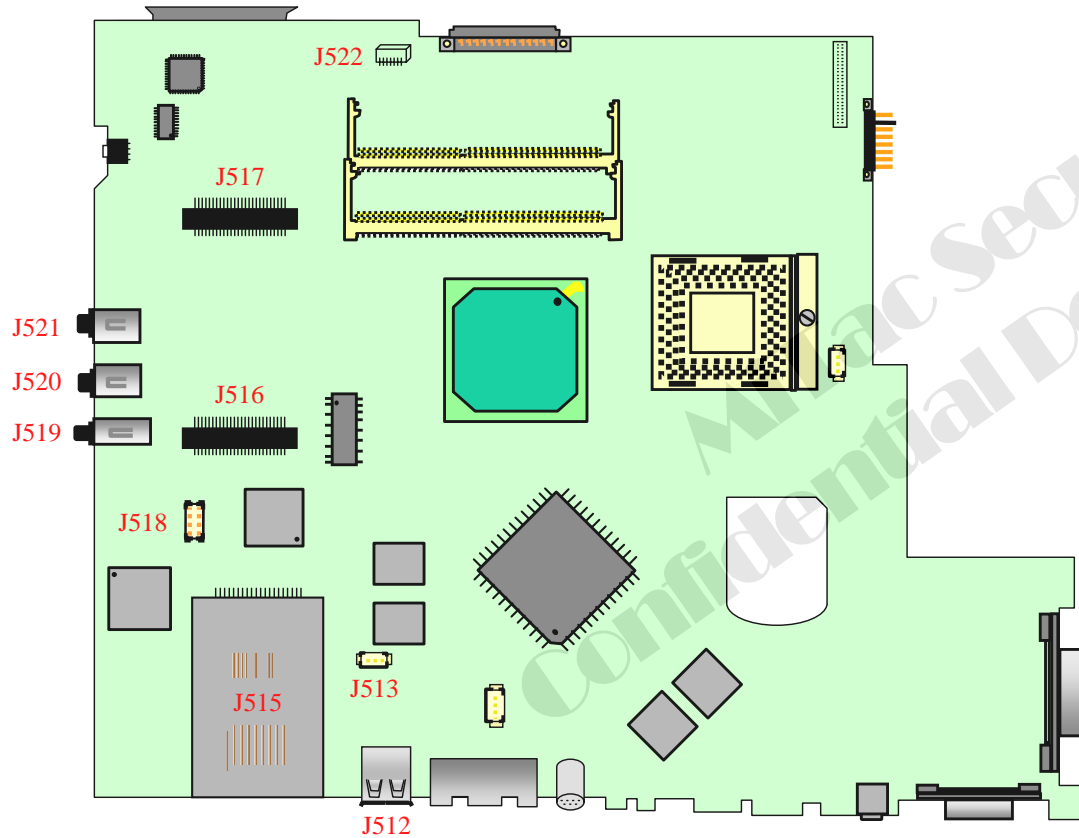

----- Continued to previous page -----

- ⊕ J512: USB Port
- ⊕ J513: RTC Connector
- ⊕ J515: CardReader Slot
- ⊕ J516: Wireless LAN Connector
- ⊕ J517: TV Card Connector
- ⊕ J518: MDC Board Connector
- ⊕ J519: SPDIF Jack
- ⊕ J520: Microphone Jack
- ⊕ J521: Line In Jack
- ⊕ J522: Blue Tooth Connector

8224 N/B Maintenance

3. Definition & Location of Connectors/Switches

3.1 Mother Board-B

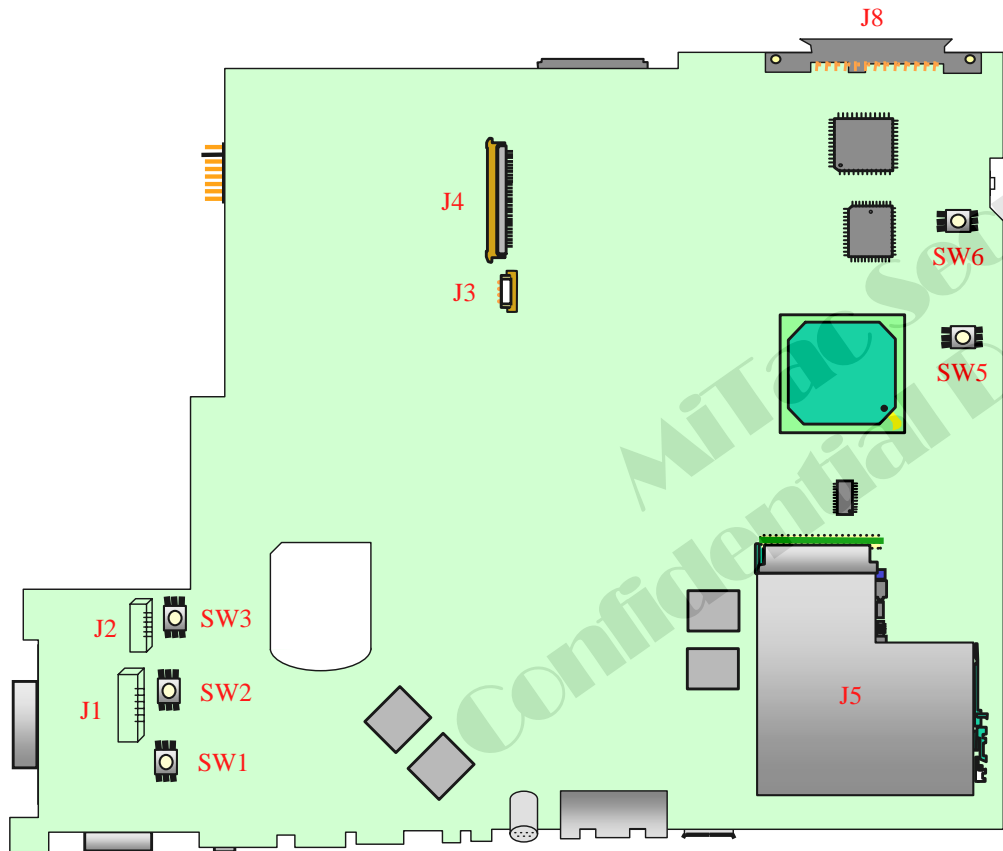

- ⊕ J1: LCD Inverter Connector
- ⊕ J2: LCD Connector
- ⊕ J3: Touch Pad Connector
- ⊕ J4: Internal Keyboard Connector
- ⊕ J5: New Card Socket
- ⊕ J8: HDD Connector

- ⊕ SW1: Instand Key
- ⊕ SW2: Mail Key
- ⊕ SW3: P1 Key
- ⊕ SW5: Touch-Pad Left Button
- ⊕ SW6: Touch-Pad Right Button

8224 N/B Maintenance

3. Definition & Location of Connectors/Switches

3.2 Daughter Board-A

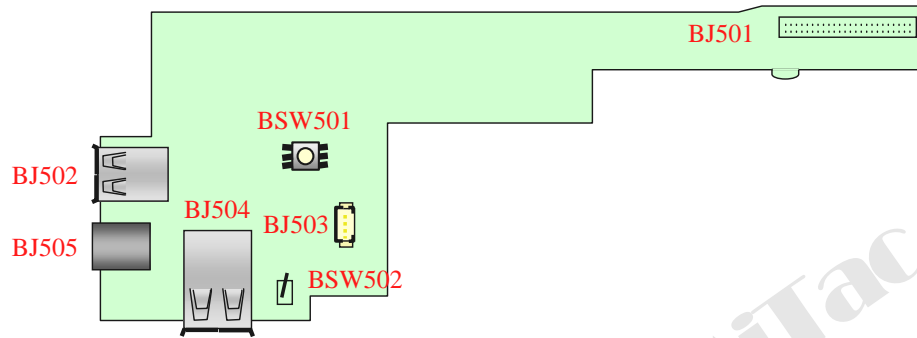

⊕ BJ501: Board to Board Connector

⊕ BJ502/BJ504: USB Port

⊕ BJ503: Speaker Jack

⊕ BJ505: Power Jack

⊕ BSW501: Power Button

⊕ BSW502: Cover Switch

MiTac Secret
Confidential Document

8224 N/B Maintenance

4. Definition & Location of Major Components

4.1 Mother Board-A

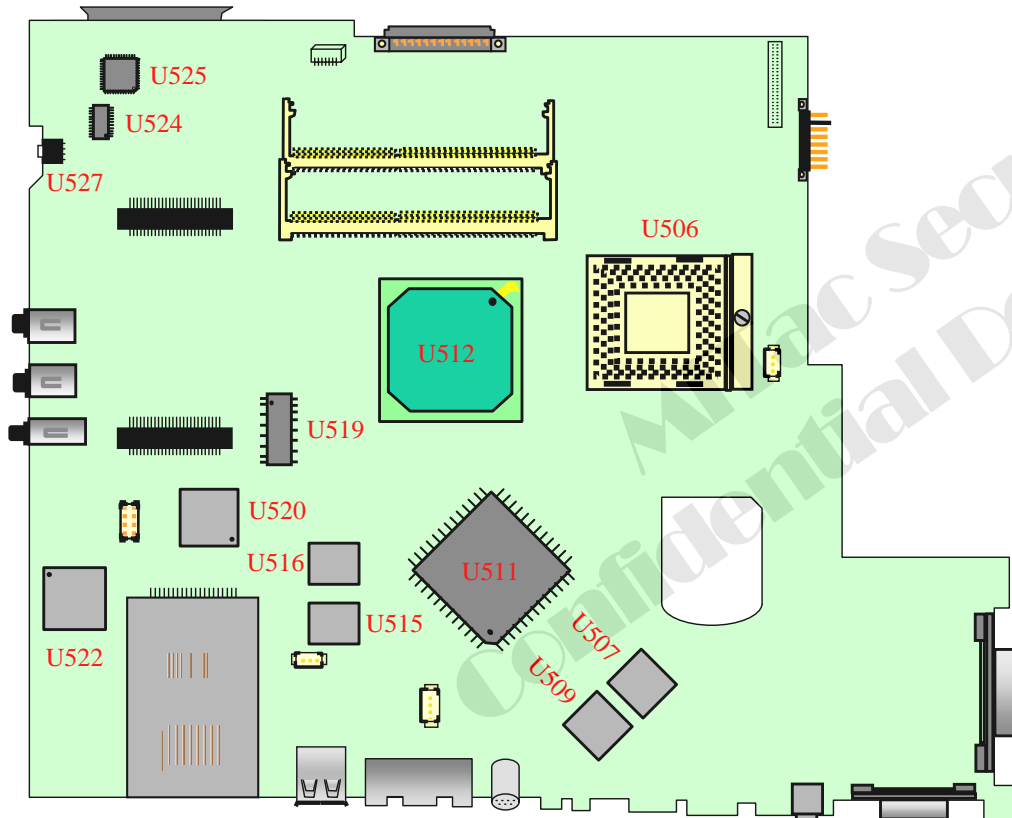

- ✦ U506: CPU (Intel Yonah) Socket
- ✦ U507, U509, U515, U516: GDDR2 VRAM
- ✦ U511: ATI M56-P
- ✦ U512: North Bridge (Intel 945GM)
- ✦ U519: ICS9LR310 Clock Generator
- ✦ U520: CardReader & IEEE1394 (PCI8402)
- ✦ U522: GIGA LAN (BCM5789)
- ✦ U524: TPA0212 Audio AMP
- ✦ U525: ALC880 Audio Codec
- ✦ U527: CIR

8224 N/B Maintenance

4. Definition & Location of Major Components

4.1 Mother Board-B

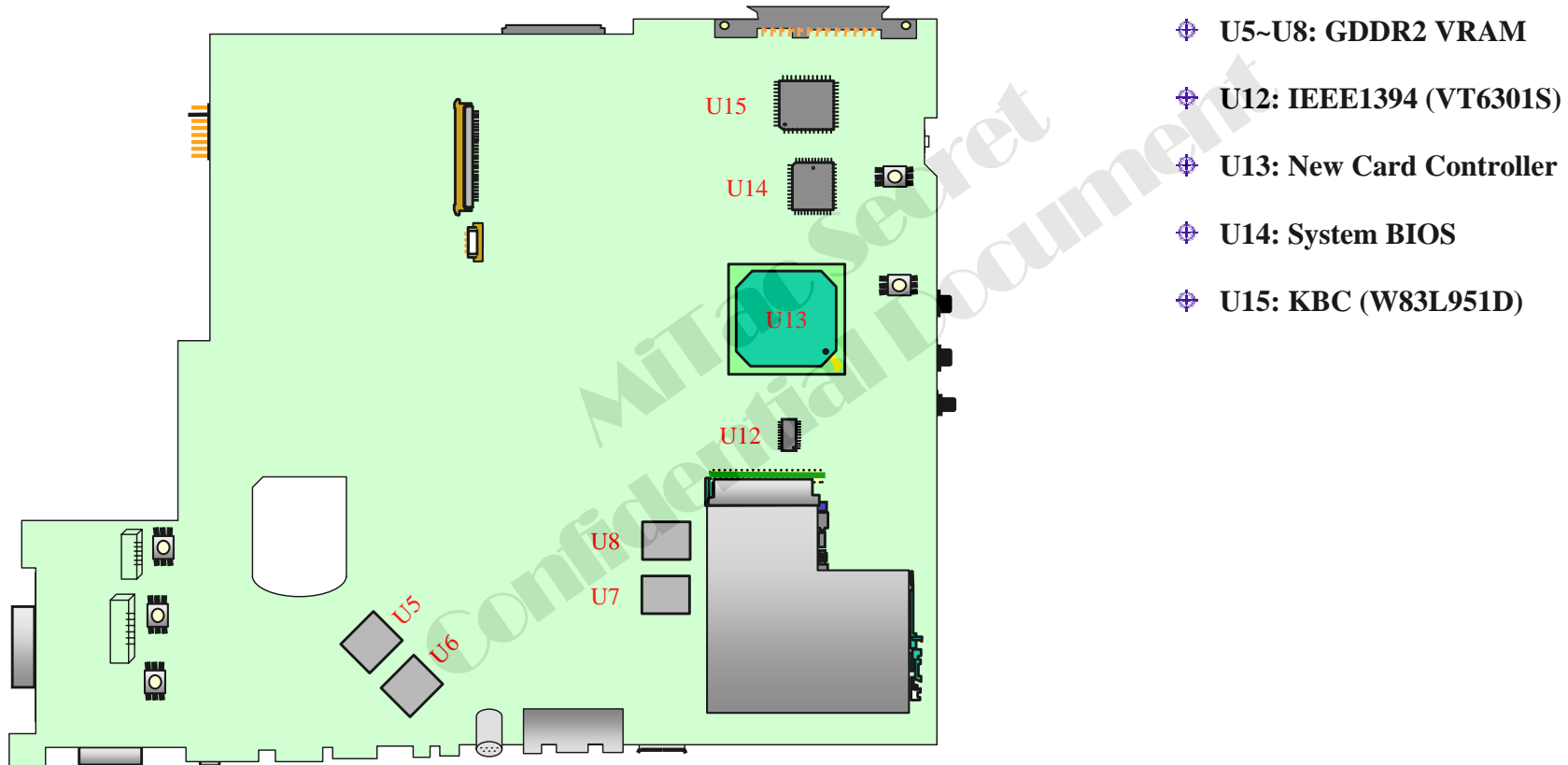

8224 N/B Maintenance

5. Pin Descriptions of Major Components

5.1 Intel 945G/945P North Bridge (1)

Host Interface Signals

Signal Name	Type	Description
HADS#	I/O GTL+	Address Strobe: The processor bus owner asserts HADS# to indicate the first of two cycles of a request phase. The (G)MCH can assert this signal for snoop cycles and interrupt messages.
HBNR#	I/O GTL+	Block Next Request: HBNR# is used to block the current request bus owner from issuing new requests. This signal is used to dynamically control the processor bus pipeline depth.
HBPRI#	O GTL+	Priority Agent Bus Request: The (G)MCH is the only Priority Agent on the processor bus. It asserts this signal to obtain the ownership of the address bus. This signal has priority over symmetric bus requests and will cause the current symmetric owner to stop issuing new transactions unless the HLOCK# signal was asserted.
HBREQ0#	I/O GTL+	Bus Request 0: The (G)MCH pulls the processor's bus HBREQ0# signal low during HCPURST#. The processor samples this signal on the active-to-inactive transition of HCPURST#. The minimum setup time for this signal is 4 HCLKs. The minimum hold time is 2 HCLKs and the maximum hold time is 20 HCLKs. HBREQ0# should be tristated after the hold time requirement has been satisfied.
HCPURST#	O GTL+	CPU Reset: The HCPURST# pin is an output from the (G)MCH. The (G)MCH asserts HCPURST# while RSTIN# is asserted and for approximately 1 ms after RSTIN# is de-asserted. The HCPURST# allows the processors to begin execution in a known state. Note that the Intel® ICH7 must provide processor frequency select strap setup and hold times around HCPURST#. This requires strict synchronization between (G)MCH HCPURST# de-assertion and the ICH7 driving the straps.
HDBSY#	I/O GTL+	Data Bus Busy: This signal is used by the data bus owner to hold the data bus for transfers requiring more than one cycle.
HDEFER#	O GTL+	Defer: HDEFER# indicates that the (G)MCH will terminate the transaction currently being snooped with either a deferred response or with a retry response.

Host Interface Signals (Continued)

Signal Name	Type	Description										
HDRDY#	I/O GTL+	Data Ready: This signal is asserted for each cycle that data is transferred.										
HEDRDY#	O GTL+	Early Data Ready: This signal indicates that the data phase of a read transaction will start on the bus exactly one common clock after assertion.										
HDINV[3:0]#	I/O GTL+	Dynamic Bus Inversion: These signals are driven along with the HD[63:0] signals. They indicate if the associated signals are inverted or not. HDINV[3:0]# are asserted such that the number of data bits driven electrically low (low voltage) within the corresponding 16 bit group never exceeds 8.. <table border="0"> <tr> <td>HDINV[x]#</td> <td>Data Bits</td> </tr> <tr> <td>HDINV3#</td> <td>HD[63:48]</td> </tr> <tr> <td>HDINV2#</td> <td>HD[47:32]</td> </tr> <tr> <td>HDINV1#</td> <td>HD[31:16]</td> </tr> <tr> <td>HDINV0#</td> <td>HD[15:0]</td> </tr> </table>	HDINV[x]#	Data Bits	HDINV3#	HD[63:48]	HDINV2#	HD[47:32]	HDINV1#	HD[31:16]	HDINV0#	HD[15:0]
HDINV[x]#	Data Bits											
HDINV3#	HD[63:48]											
HDINV2#	HD[47:32]											
HDINV1#	HD[31:16]											
HDINV0#	HD[15:0]											
HA[31:3]#	I/O GTL+	Host Address Bus: HA[31:3]# connect to the processor address bus. During processor cycles, the HA[31:3]# are inputs. The (G)MCH drives HA[31:3]# during snoop cycles on behalf of DMI and PCI Express* initiators. HA[31:3]# are transferred at 2x rate.										
HADSTB[1:0]#	I/O GTL+	Host Address Strobe: These signals are the source synchronous strobes used to transfer HA[31:3]# and HREQ[4:0] at the 2x transfer rate.										
HD[63:0]#	I/O GTL+	Host Data: These signals are connected to the processor data bus. Data on HD[63:0] is transferred at 4x rate. Note that the data signals may be inverted on the processor bus, depending on the HDINV[3:0]# signals.										
HHIT#	I/O GTL+	Hit: This signal indicates that a caching agent holds an unmodified version of the requested line. In addition, HHIT# is driven in conjunction with HHITM# by the target to extend the snoop window.										

8224 N/B Maintenance

5.1 Intel 945G/945P North Bridge (2)

Host Interface Signals (Continued)

Signal Name	Type	Description															
HDSTBP[3:0]# HDSTBN[3:0]#	I/O GTL+	Differential Host Data Strobes: These signals are the differential source synchronous strobes used to transfer HD[63:0]# and HDINV[3:0]# at 4x transfer rate. These signals are named this way because they are not level sensitive. Data is captured on the falling edge of both strobes. Hence they are pseudo-differential, and not true differential. <table border="1"> <thead> <tr> <th>Strobe</th> <th>Data</th> <th>Bits</th> </tr> </thead> <tbody> <tr> <td>HDSTBP3#, HDSTBN3#</td> <td>HD[63:48]</td> <td>HDINV3#</td> </tr> <tr> <td>HDSTBP2#, HDSTBN2#</td> <td>HD[47:32]</td> <td>HDINV2#</td> </tr> <tr> <td>HDSTBP1#, HDSTBN1#</td> <td>HD[31:16]</td> <td>HDINV1#</td> </tr> <tr> <td>HDSTBP0#, HDSTBN0#</td> <td>HD[15:00]</td> <td>HDINV0#</td> </tr> </tbody> </table>	Strobe	Data	Bits	HDSTBP3#, HDSTBN3#	HD[63:48]	HDINV3#	HDSTBP2#, HDSTBN2#	HD[47:32]	HDINV2#	HDSTBP1#, HDSTBN1#	HD[31:16]	HDINV1#	HDSTBP0#, HDSTBN0#	HD[15:00]	HDINV0#
Strobe	Data	Bits															
HDSTBP3#, HDSTBN3#	HD[63:48]	HDINV3#															
HDSTBP2#, HDSTBN2#	HD[47:32]	HDINV2#															
HDSTBP1#, HDSTBN1#	HD[31:16]	HDINV1#															
HDSTBP0#, HDSTBN0#	HD[15:00]	HDINV0#															
HHITM#	I/O GTL+	Hit Modified: This signal indicates that a caching agent holds a modified version of the requested line and that this agent assumes responsibility for providing the line. In addition, HHITM# is driven in conjunction with HHIT# to extend the snoop window.															
HLOCK#	I/O GTL+	Host Lock: All processor bus cycles sampled with the assertion of HLOCK# and HADS#, until the negation of HLOCK# must be atomic (i.e., no DMI or PCI Express accesses to DRAM are allowed when HLOCK# is asserted by the processor).															
HPCREQ#	I GTL+ 2X	Precharge Request: The processor provides a “hint” to the (G)MCH that it is OK to close the DRAM page of the memory read request with which the hint is associated. The (G)MCH uses this information to schedule the read request to memory using the special “AutoPrecharge” attribute. This causes the DRAM to immediately close (Precharge) the page after the read data has been returned. This allows subsequent processor requests to more quickly access information on other DRAM pages, since it will no longer be necessary to close an open page prior to opening the proper page. HPCREQ# is asserted by the requesting agent during both halves of Request Phase. The same information is provided in both halves of the request phase.															
HREQ[4:0]#	I/O GTL+ 2X	Host Request Command: These signals define the attributes of the request. HREQ[4:0]# are transferred at 2x rate. They are asserted by the requesting agent during both halves of Request Phase. In the first half, the signals define the transaction type to a level of detail that is sufficient to begin a snoop request. In the second half, the signals carry additional information to define the complete transaction type.															

Host Interface Signals (Continued)

Signal Name	Type	Description
HTRDY#	O GTL+	Host Target Ready: This signal indicates that the target of the processor transaction is able to enter the data transfer phase.
HRS[2:0]#	O GTL+	Host Response Status: These signals indicate the type of response as shown below: 000 = Idle state 001 = Retry response 010 = Deferred response 011 = Reserved (not driven by (G)MCH) 100 = Hard Failure (not driven by (G)MCH) 101 = No data response 110 = Implicit Write back 111 = Normal data response
BSEL[2:0]	I COMS	Bus Speed Select: At the de-assertion of RSTIN#, the value sampled on these pins determines the expected frequency of the bus.
HRCOMP	I/O COMS	Host RCOMP: This signal is used to calibrate the Host GTL+ I/O buffers. This signal is powered by the Host Interface termination rail (V _{TT}).
HSCOMP	I/O COMS	Slew Rate Compensation: This is the compensation signal for the Host Interface.
HSWING	I A	Host Voltage Swing: This signal provides the reference voltage used by FSB RCOMP circuits. HSWING is used for the signals handled by HRCOMP.
HDVREF	I A	Host Reference Voltage: Voltage input for the data, address, and common clock signals of the Host GTL interface.
HACCVREF	I A	Host Reference Voltage: Reference voltage input for the Address, and Common clock signals of the Host GTL interface.

Note: Unless otherwise noted, the voltage level for all signals in this interface is tied to the termination voltage of the Host Bus (V_{TT}).

8224 N/B Maintenance

5.1 Intel 945G/945P North Bridge (3)

DDR2 DRAM Channel A Interface

Signal Name	Type	Description
SCLK_A[5:0]	O SSTL-1.8	SDRAM Differential Clock: (3 per DIMM). SCLK_Ax and its complement SCLK_Ax# signal make a differential clock pair output. The crossing of the positive edge of SCLK_Ax and the negative edge of its complement SCLK_Ax# are used to sample the command and control signals on the SDRAM.
SCLK_A[5:0]#	O SSTL-1.8	SDRAM Complementary Differential Clock: (3 per DIMM). These are the complementary Differential DDR2 Clock signals.
SCS_A[3:0]#	O SSTL-1.8	Chip Select: (1 per Rank). These signals select particular SDRAM components during the active state. There is one chip select for each SDRAM rank.
SMA_A[13:0]	O SSTL-1.8	Memory Address: These signals are used to provide the multiplexed row and column address to the SDRAM.
SBS_A[2:0]	O SSTL-1.8	Bank Select: These signals define which banks are selected within each SDRAM rank. DDR2: 1-Gb technology is 8 banks.
SRAS_A#	O SSTL-1.8	Row Address Strobe: This signal is used with SCAS_A# and SWE_A# (along with SCS_A#) to define the SDRAM commands.
SCAS_A#	O SSTL-1.8	Column Address Strobe: This signal is used with SRAS_A# and SWE_A# (along with SCS_A#) to define the SDRAM commands.
SWE_A#	O SSTL-1.8	Write Enable: This signal is used with SCAS_A# and SRAS_A# (along with SCS_A#) to define the SDRAM commands.
SDQ_A[63:0]	I/O SSTL-1.8 2X	Data Lines: The SDQ_A[63:0] signals interface to the SDRAM data bus.
SDM_A[7:0]	O SSTL-1.8 2X	Data Mask: When activated during writes, the corresponding data groups in the SDRAM are masked. There is one SDM_Ax bit for every data byte lane.
SDQS_A[7:0]	I/O SSTL-1.8 2X	Data Strobes: For DDR2, SDQS_Ax and its complement SDQS_Ax# signal make up a differential strobe pair. The data is captured at the crossing point of SDQS_Ax and its complement SDQS_Ax# during read and write transactions.

DDR2 DRAM Channel A Interface (Continued)

Signal Name	Type	Description
SDQS_A[7:0]#	I/O SSTL-1.8 2X	Data Strobe Complements: These are the complementary DDR2 strobe signals.
SCKE_A[3:0]	O SSTL-1.8	Clock Enable: (1 per Rank). SCKE_Ax is used to initialize the SDRAMs during power-up, to power-down SDRAM ranks, and to place all SDRAM ranks into and out of self-refresh during Suspend-to-RAM.
SODT_A[3:0]	O SSTL-1.8	On Die Termination: Active On-die Termination Control signals for DDR2 devices.

DDR2 DRAM Channel B Interface

Signal Name	Type	Description
SCLK_B[5:0]	O SSTL-1.8	SDRAM Differential Clock: (3 per DIMM). SCLK_Bx and its complement SCLK_Bx# signal make a differential clock pair output. The crossing of the positive edge of SCLK_Bx and the negative edge of its complement SCLK_Bx# are used to sample the command and control signals on the SDRAM.
SCLK_B[5:0]#	O SSTL-1.8	SDRAM Complementary Differential Clock: (3 per DIMM). These are the complementary Differential DDR2 Clock signals.
SCS_B[3:0]#	O SSTL-1.8	Chip Select: (1 per Rank). These signals select particular SDRAM components during the active state. There is one chip select for each SDRAM rank.
SMA_B[13:0]	O SSTL-1.8	Memory Address: These signals are used to provide the multiplexed row and column address to the SDRAM.
SBS_B[2:0]	O SSTL-1.8	Bank Select: These signals define which banks are selected within each SDRAM rank. DDR2: 1-Gb technology is 8 banks.
SRAS_B#	O SSTL-1.8	Row Address Strobe: This signal is used with SCAS_B# and SWE_B# (along with SCS_B#) to define the SDRAM commands.

8224 N/B Maintenance

5.1 Intel 945G/945P North Bridge (4)

DDR2 DRAM Channel B Interface (Continued)

Signal Name	Type	Description
SCAS_B#	O SSTL-1.8	Column Address Strobe: This signal is used with SRAS_B# and SWE_B# (along with SCS_B#) to define the SDRAM commands.
SWE_B#	O SSTL-1.8	Write Enable: This signal is used with SCAS_B# and SRAS_B# (along with SCS_B#) to define the SDRAM commands.
SDQ_B[63:0]	I/O SSTL-1.8 2X	Data Lines: The SDQ_B[63:0] signals interface to the SDRAM data bus.
SDM_B[7:0]	O SSTL-1.8 2X	Data Mask: When activated during writes, the corresponding data groups in the SDRAM are masked. There is one SDM_Bx bit for every data byte lane.
SDQS_B[7:0]	I/O SSTL-1.8 2X	Data Strobes: For DDR2, SDQS_Bx and its complement SDQS_Bx# signal make up a differential strobe pair. The data is captured at the crossing point of SDQS_Bx and its complement SDQS_Bx# during read and write transactions.
SDQS_B[7:0]#	I/O SSTL-1.8 2X	Data Strobe Complements: These are the complementary DDR2 strobe signals.
SCKE_B[3:0]	O SSTL-1.8	Clock Enable: (1 per Rank). SCKE_Bx is used to initialize the SDRAMs during power-up, to power-down SDRAM ranks, and to place all SDRAM ranks into and out of self-refresh during Suspend-to-RAM.
SODT_B[3:0]	O SSTL-1.8	On Die Termination: Active On-die Termination Control signals for DDR2 devices.

PCI Express* Interface Signals

Signal Name	Type	Description
EXP_RXN[15:0] EXP_RXP[15:0]	I/O PCIE	PCI Express* Receive Differential Pair
EXP_TXN[15:0] EXP_TXP[15:0]	O PCIE	PCI Express* Transmit Differential Pair
EXP_ICOMPO	I A	PCI Express* Output Current and Resistance Compensation
EXP_COMPI	I A	PCI Express* Input Current Compensation

Unless otherwise specified, PCI Express signals are AC coupled, so the only voltage specified is a maximum 1.2 V differential swing.

Analog Display Signals (Intel® 82945G GMCH Only)

Signal Name	Type	Description
RED	O A	RED Analog Video Output: This signal is a CRT Analog video output from the internal color palette DAC. The DAC is designed for a 37.5 routing impedance; however, the terminating resistor to ground will be 75 (e.g., 75 resistor on the board, in parallel with a 75 CRT load).
RED#	O A	REDB Analog Output: This signal is an analog video output from the internal color palette DAC. It should be shorted to the ground plane.
GREEN	O A	GREEN Analog Video Output: This signal is a CRT Analog video output from the internal color palette DAC. The DAC is designed for a 37.5 routing impedance; however, the terminating resistor to ground will be 75 (e.g., 75 resistor on the board, in parallel with a 75 CRT load).
GREEN#	O A	GREENB Analog Output: This signal is an analog video output from the internal color palette DAC. It should be shorted to the ground plane.
BLUE	O A	BLUE Analog Video Output: This signal is a CRT Analog video output from the internal color palette DAC. The DAC is designed for a 37.5 routing impedance; however, the terminating resistor to ground will be 75 (e.g., 75 resistor on the board, in parallel with a 75 CRT load).
BLUE#	O A	BLUEB Analog Output: This signal is an analog video output from the internal color palette DAC. It should be shorted to the ground plane.
REFSET	O A	Resistor Set: Set point resistor for the internal color palette DAC. A 255 1% resistor is required between REFSET and motherboard ground.
HSYNC	O 2.5V CMOS	CRT Horizontal Synchronization: This signal is used as the horizontal sync (polarity is programmable) or "sync interval". 2.5 V output.
VSYNC	O 2.5V CMOS	CRT Vertical Synchronization: This signal is used as the vertical sync (polarity is programmable). 2.5 V output.
DDC_CLK	I/O 2.5V CMOS	Monitor Control Clock: This signal may be used as the DDC_CLK for a secondary multiplexed digital display connector.
DDC_DATA	I/O 2.5V CMOS	Monitor Control Data: This signal may be used as the DDC_Data for a secondary multiplexed digital display connector.

8224 N/B Maintenance

5.1 Intel 945G/945P North Bridge (5)

Clock, Reset, and Miscellaneous

Signal Name	Type	Description
HCLKP HCLKN	I HCSL	Differential Host Clock In: These pins receive a differential host clock from the external clock synthesizer. This clock is used by all of the (G)MCH logic that is in the Host clock domain. Memory domain clocks are also derived from this source.
GCLKP GCLKN	I HCSL	Differential PCI Express* Clock In: These pins receive a differential 100 MHz Serial Reference clock from the external clock synthesizer. This clock is used to generate the clocks necessary for the support of PCI Express.
DREFCLKN DREFCLKP	I HCSL	Display PLL Differential Clock In
RSTIN#	I HVIN	Reset In: When asserted, this signal will asynchronously reset the (G)MCH logic. This signal is connected to the PCIRST# output of the Intel® ICH7. All PCI Express graphics attach output signals will also tri-state compliant to <i>PCI Express* Specification, Revision 1.0a</i> . This input should have a Schmitt trigger to avoid spurious resets. This signal is required to be 3.3 V tolerant.
PWROK	I HVIN	Power OK: When asserted, PWROK is an indication to the (G)MCH that core power has been stable for at least 10 us.
EXTTS#	I CMOS	External Thermal Sensor Input: This signal may connect to a precision thermal sensor located on or near the DIMMs. If the system temperature reaches a dangerously high value, then this signal can be used to trigger the start of system thermal management. This signal is activated when an increase in temperature causes a voltage to cross some threshold in the sensor.
EXP_EN	I CMOS	PCI Express SDVO Concurrent Select: 0 = Only SDVO or PCI Express operational 1 = SDVO and PCI Express operating simultaneously via PCI Express port NOTES: For the 82945P MCH, this signal should be pulled low.
EXP_SLR	I CMOS	PCI Express* Lane Reversal/Form Factor Selection: (G)MCH's PCI Express lane numbers are reversed to differentiate Balanced Technology Extended (BTX) or ATX form factors. 0 = (G)MCH's PCI Express lane numbers are reversed (BTX Platforms) 1 = Normal operation (ATX Platforms)
ICH_SYNC#	O HVCMOS	ICH Sync: This signal is connected to the MCH_SYNCH# signal on the ICH7.

Clock, Reset, and Miscellaneous (Continued)

Signal Name	Type	Description
XORTEST	I/O GTL+	XOR Test: This signal is used for Bed of Nails testing by OEMs to execute XOR Chain test.
LLZTEST	I/O GTL+	All Z Test: As an input this signal is used for Bed of Nails testing by OEMs to execute XOR Chain test. It is used as an output for XOR chain testing.

DDR2 DRAM Reference and Compensation

Signal Name	Type	Description
SRCOMP[1:0]	I/O	System Memory RCOMP
SOCOMP[1:0]	I/O A	DDR2 On-Die DRAM Over Current Detection (OCD) Driver Compensation
SMVREF[1:0]	I A	SDRAM Reference Voltage: These signals are reference voltage inputs for each SDQ_x, SDM_x, SDQS_x, and SDQS_x# input signals.

Direct Media Interface (DMI)

Signal Name	Type	Description
DMI_RXP[3:0]	I/O	Direct Media Interface: These signals are receive differential pairs (Rx).
DMI_RXN[3:0]	DMI	
DMI_TXP[3:0]	O	Direct Media Interface: These signals are transmit differential pairs (Tx).
DMI_TXN[3:0]	DMI	

8224 N/B Maintenance

5.1 Intel 945G/945P North Bridge (6)

Intel® Serial DVO (SDVO) Interface (Intel® 82945G GMCH Only)

Signal Name	Type	Description
SDVOB_CLK-	O PCIE	Serial Digital Video Channel B Clock Complement: This signal is multiplexed with EXP_TXN12.
SDVOB_CLK+	O PCIE	Serial Digital Video Channel B Clock Clock: This signal is multiplexed with EXP_TXP12.
SDVOB_RED-	O PCIE	Serial Digital Video Channel C Red Complement: This signal is multiplexed with EXP_TXN15.
SDVOB_RED+	O PCIE	Serial Digital Video Channel C Red: This signal is multiplexed with EXP_TXP15.
SDVOB_GREEN-	O PCIE	Serial Digital Video Channel B Green Complement: This signal is multiplexed with EXP_TXN14.
SDVOB_GREEN+	O PCIE	Serial Digital Video Channel B Green: This signal is multiplexed with EXP_TXP14.
SDVOB_BLUE-	O PCIE	Serial Digital Video Channel B Blue Complement: This signal is multiplexed with EXP_TXN13.
SDVOB_BLUE+	O PCIE	Serial Digital Video Channel B Blue: This signal is multiplexed with EXP_TXP13.
SDVOC_RED-/SDVOB_ALPHA-	O PCIE	Serial Digital Video Channel C Red Complement Channel B Alpha Complement: This signal is multiplexed with EXP_TXN11.
SDVOC_RED+/SDVOB_ALPHA+	O PCIE	Serial Digital Video Channel C Red Complement Channel B Alpha: This signal is multiplexed with EXP_TXP11.
SDVOC_GREEN-	O PCIE	Serial Digital Video Channel C Green Complement: This signal is multiplexed with EXP_TXN10.
SDVOC_GREEN+	O PCIE	Serial Digital Video Channel C Green: This signal is multiplexed with EXP_TXP10.
SDVOC_BLUE-	O PCIE	Serial Digital Video Channel C Blue Complement: This signal is multiplexed with EXP_TXN9.
SDVOC_BLUE+	O PCIE	Serial Digital Video Channel C Blue: This signal is multiplexed with EXP_TXP9.
SDVOC_CLK-	O PCIE	Serial Digital Video Channel C Clock Complement: This signal is multiplexed with EXP_TXN8.
SDVOC_CLK+	O PCIE	Serial Digital Video Channel C Clock: This signal is multiplexed with EXP_TXP8.
SDVO_TVCLKIN-	I PCIE	Serial Digital Video TV-OUT Synchronization Clock Complement: This signal is multiplexed with EXP_RXN15.
SDVO_TVCLKIN+	I PCIE	Serial Digital Video TV-OUT Synchronization Clock: This signal is multiplexed with EXP_RXP15.
SDVOB_INT-	I PCIE	Serial Digital Video Input Interrupt Complement: This signal is multiplexed with EXP_RXN14.

Intel® Serial DVO (SDVO) Interface (Intel® 82945G GMCH Only) (Continued)

Signal Name	Voltage	Description
SDVOB_INT+	I PCIE	Serial Digital Video Input Interrupt: This signal is multiplexed with EXP_RXP14.
SDVOC_INT-	I PCIE	Serial Digital Video Input Interrupt Complement: This signal is multiplexed with EXP_RXN10.
SDVOC_INT+	I PCIE	Serial Digital Video Input Interrupt: This signal is multiplexed with EXP_RXP10.
SDVO_STALL-	I PCIE	Serial Digital Video Filed Stall Complement: This signal is multiplexed with EXP_RXN13.
SDVO_STALL+	I PCIE	Serial Digital Video Filed Stall: This signal is multiplexed with EXP_RXP13.
SDVO_CTRLCLK	I/O COD	Serial Digital Video Device Control Clock.
SDVO_CTRLDATA	I/O COD	Serial Digital Video Device Control Data.

Power and Ground

Name	Voltage	Description
VCC	1.5V	Core Power
VT	1.2V	Processor System Bus Power
VCC_EXP	1.5V	PCI Express* and DMI Power
VCCSM	1.8V	System Memory Power
VCC2	2.5V	2.5V COMS Power
VCCA_EXPPLL	1.5V	PCI Express PLL Analog Power
VCCA_DPLLA (GMCH ONLY)	1.5V	Display PLL A Analog Power
VCCA_DPLLB (GMCH ONLY)	1.5V	Display PLL B Analog Power
VCCA_HPLL	1.5V	Host PLL Analog Power
VCCA_SMPPLL	1.5V	System Memory PLL Analog Power
VCCA_DAC	2.5V	Display DAC Analog Power
VSS	0V	Ground
VSSA_DAC	0V	Ground

8224 N/B Maintenance

5.2 Intel ICH7-M South Bridge (1)

PCI Interface Signals

Signal Name	Type	Description
IRDY#	I/O	Initiator Ready: IRDY# indicates the ICH7's ability, as an initiator, to complete the current data phase of the transaction. It is used in conjunction with TRDY#. A data phase is completed on any clock both IRDY# and TRDY# are sampled asserted. During a write, IRDY# indicates the ICH7 has valid data present on AD[31:0]. During a read, it indicates the ICH7 is prepared to latch data. IRDY# is an input to the ICH7 when the ICH7 is the target and an output from the ICH7 when the ICH7 is an initiator. IRDY# remains tri-stated by the ICH7 until driven by an initiator.
TRDY#	I/O	Target Ready: TRDY# indicates the Intel® ICH7's ability as a target to complete the current data phase of the transaction. TRDY# is used in conjunction with IRDY#. A data phase is completed when both TRDY# and IRDY# are sampled asserted. During a read, TRDY# indicates that the ICH7, as a target, has placed valid data on AD[31:0]. During a write, TRDY# indicates the ICH7, as a target is prepared to latch data. TRDY# is an input to the ICH7 when the ICH7 is the initiator and an output from the ICH7 when the ICH7 is a target. TRDY# is tri-stated from the leading edge of PLTRST#. TRDY# remains tri-stated by the ICH7 until driven by a target.
STOP#	I/O	Stop: STOP# indicates that the ICH7, as a target, is requesting the initiator to stop the current transaction. STOP# causes the ICH7, as an initiator, to stop the current transaction. STOP# is an output when the ICH7 is a target and an input when the ICH7 is an initiator.
PAR	I/O	Calculated/Checked Parity: PAR uses "even" parity calculated on 36 bits, AD[31:0] plus C/BE[3:0]#. "Even" parity means that the ICH7 counts the number of one within the 36 bits plus PAR and the sum is always even. The ICH7 always calculates PAR on 36 bits regardless of the valid byte enables. The ICH7 generates PAR for address and data phases and only guarantees PAR to be valid one PCI clock after the corresponding address or data phase. The ICH7 drives and tristates PAR identically to the AD[31:0] lines except that the ICH7 delays PAR by exactly one PCI clock. PAR is an output during the address phase (delayed one clock) for all ICH7 initiated transactions. PAR is an output during the data phase (delayed one clock) when the ICH7 is the initiator of a PCI write transaction, and when it is the target of a read transaction. ICH7 checks parity when it is the target of a PCI write transaction. If a parity error is detected, the ICH7 will set the appropriate internal status bits, and has the option to generate an NMI# or SMI#.

PCI Interface Signals (Continued)

Name	Type	Description																						
AD[31:0]	I/O	PCI Address/Data: AD[31:0] is a multiplexed address and data bus. During the first clock of a transaction, AD[31:0] contain a physical address (32 bits). During subsequent clocks, AD[31:0] contain data. The Intel® ICH7 will drive all 0s on AD[31:0] during the address phase of all PCI Special Cycles.																						
C/BE[3:0]#	I/O	Bus Command and Byte Enables: The command and byte enable signals are multiplexed on the same PCI pins. During the address phase of a transaction, C/BE[3:0]# define the bus command. During the data phase C/BE[3:0]# define the Byte Enables. C/BE[3:0]# Command Type <table border="0"> <tr> <td>0000b</td> <td>Interrupt Acknowledge</td> </tr> <tr> <td>0001b</td> <td>Special Cycle</td> </tr> <tr> <td>0010b</td> <td>I/O Read</td> </tr> <tr> <td>0011b</td> <td>I/O Write</td> </tr> <tr> <td>0110b</td> <td>Memory Read</td> </tr> <tr> <td>0111b</td> <td>Memory Write</td> </tr> <tr> <td>1010b</td> <td>Configuration Read</td> </tr> <tr> <td>1011b</td> <td>Configuration Write</td> </tr> <tr> <td>1100b</td> <td>Memory Read Multiple</td> </tr> <tr> <td>1110b</td> <td>Memory Read Line</td> </tr> <tr> <td>1111b</td> <td>Memory Write and Invalidate</td> </tr> </table> All command encodings not shown are reserved. The ICH7 does not decode reserved values, and therefore will not respond if a PCI master generates a cycle using one of the reserved values.	0000b	Interrupt Acknowledge	0001b	Special Cycle	0010b	I/O Read	0011b	I/O Write	0110b	Memory Read	0111b	Memory Write	1010b	Configuration Read	1011b	Configuration Write	1100b	Memory Read Multiple	1110b	Memory Read Line	1111b	Memory Write and Invalidate
0000b	Interrupt Acknowledge																							
0001b	Special Cycle																							
0010b	I/O Read																							
0011b	I/O Write																							
0110b	Memory Read																							
0111b	Memory Write																							
1010b	Configuration Read																							
1011b	Configuration Write																							
1100b	Memory Read Multiple																							
1110b	Memory Read Line																							
1111b	Memory Write and Invalidate																							
DEVSEL#	I/O	Device Select: The ICH7 asserts DEVSEL# to claim a PCI transaction. As an output, the ICH7 asserts DEVSEL# when a PCI master peripheral attempts an access to an internal ICH7 address or an address destined DMI (main memory or graphics). As an input, DEVSEL# indicates the response to an ICH7-initiated transaction on the PCI bus. DEVSEL# is tri-stated from the leading edge of PLTRST#. DEVSEL# remains tri-stated by the ICH7 until driven by a target device.																						
FRAME#	I/O	Cycle Frame: The current initiator drives FRAME# to indicate the beginning and duration of a PCI transaction. While the initiator asserts FRAME#, data transfers continue. When the initiator negates FRAME#, the transaction is in the final data phase. FRAME# is an input to the ICH7 when the ICH7 is the target, and FRAME# is an output from the ICH7 when the ICH7 is the initiator. FRAME# remains tristated by the ICH7 until driven by an initiator.																						

8224 N/B Maintenance

5.2 Intel ICH7-M South Bridge (2)

PCI Interface Signals (Continued)

Signal Name	Type	Description
PERR#	I/O	Parity Error: An external PCI device drives PERR# when it receives data that has a parity error. The ICH7 drives PERR# when it detects a parity error. The ICH7 can either generate an NMI# or SMI# upon detecting a parity error (either detected internally or reported via the PERR# signal).
REQ[0:3]# REQ[4]#/ GPIO22 REQ[5]#/GPIO1	I	PCI Requests: The ICH7 supports up to 6 masters on the PCI bus. The REQ[4]# and REQ5# pins can instead be used as a GPIO.
GNT[0:3]# GNT[4]#/ GPIO48 GNT[5]#/ GPIO17#	O	PCI Grants: The ICH7 supports up to 6 masters on the PCI bus. The GNT4# and GNT5# pins can instead be used as a GPIO. Pull-up resistors are not required on these signals. If pull-ups are used, they should be tied to the Vcc3_3 power rail. GNT5#/GPIO17 has an internal pull-up.
PCICLK	I	NOTE: PCI Clock: This is a 33 MHz clock. PCICLK provides timing for all transactions on the PCI Bus.
PCIRST#	O	PCI Reset: This is the Secondary PCI Bus reset signal. It is a logical OR of the primary interface PLTRST# signal and the state of the Secondary Bus Reset bit of the Bridge Control register (D30:F0:3Eh, bit 6).
PLOCK#	I/O	PCI Lock: This signal indicates an exclusive bus operation and may require multiple transactions to complete. The ICH7 asserts PLOCK# when it performs non-exclusive transactions on the PCI bus. PLOCK# is ignored when PCI masters are granted the bus in desktop configurations.
SERR#	I/OD	System Error: SERR# can be pulsed active by any PCI device that detects a system error condition. Upon sampling SERR# active, the ICH7 has the ability to generate an NMI, SMI#, or interrupt.
PME#	I/OD	PCI Power Management Event: PCI peripherals drive PME# to wake the system from low-power states S1–S5. PME# assertion can also be enabled to generate an SCI from the S0 state. In some cases the ICH7 may drive PME# active due to an internal wake event. The ICH7 will not drive PME# high, but it will be pulled up to VccSus3_3 by an internal pull-up resistor.

Serial ATA Interface Signals

Name	Type	Description
SATA0TXP SATA0TXN	O	Serial ATA 0 Differential Transmit Pair: These are outbound high-speed differential signals to Port 0.
SATA0RXP SATA0RXN	I	Serial ATA 0 Differential Receive Pair: These are inbound high-speed differential signals from Port 0.
SATA1TXP SATA1TXN	O	Serial ATA 1 Differential Transmit Pair: These are outbound high-speed differential signals to Port 1.
SATA1RXP SATA1RXN	I	Serial ATA 1 Differential Receive Pair: These are inbound high-speed differential signals from Port 1.
SATA2TXP SATA2TXN	O	Serial ATA 2 Differential Transmit Pair: These are outbound high-speed differential signals to Port 2.
SATA2RXP SATA2RXN	I	Serial ATA 2 Differential Receive Pair: These are inbound high-speed differential signals from Port 2.
SATA3TXP SATA3TXN	O	Serial ATA 3 Differential Transmit Pair: These are outbound high-speed differential signals to Port 3.
SATA3RXP SATA3RXN	I	Serial ATA 3 Differential Receive Pair: These are inbound high-speed differential signals from Port 3.
SATARBIAS	O	Serial ATA Resistor Bias: These are analog connection points for an external resistor to ground.
SATARBIAS#	I	Serial ATA Resistor Bias Complement: These are analog connection points for an external resistor to ground.
SATA0GP/ GPIO21	I	Serial ATA 0 General Purpose: This is an input pin which can be configured as an interlock switch corresponding to SATA Port 0. When used as an interlock switch status indication, this signal should be drive to '0' to indicate that the switch is closed and to '1' to indicate that the switch is open. If interlock switches are not required, this pin can be configured as GPIO21.
SATA1GP/ GPIO19	I	Serial ATA 1 General Purpose: Same function as SATA0GP, except for SATA Port 1. If interlock switches are not required, this pin can be configured as GPIO19.
SATA2GP/ GPIO36	I	Serial ATA 2 General Purpose: Same function as SATA0GP, except for SATA Port 2. If interlock switches are not required, this pin can be configured as GPIO36.

8224 N/B Maintenance

5.2 Intel ICH7-M South Bridge (3)

Serial ATA Interface Signals (Continued)

Name	Type	Description
SATA3GP/ GPIO37	I	Serial ATA 3 General Purpose: Same function as SATA0GP, except for SATA Port 3. If interlock switches are not required, this pin can be configured as GPIO37.
SATALED#	OC	Serial ATA LED: This is an open-collector output pin driven during SATA command activity. It is to be connected to external circuitry that can provide the current to drive a platform LED. When active, the LED is on. When tri-stated, the LED is off. An external pull-up resistor to Vcc3_3 is required. NOTE: An internal pull-up is enabled only during PLTRST# assertion.
SATACLKREQ #/GPIO35	OD (Native)/ I/O (GP)	Serial ATA Clock Request: This is an open-drain output pin when configured as SATACLKREQ#. It is to connect to the system clock chip. When active, request for SATA Clock running is asserted. When tri-stated, it tells the Clock Chip that SATA Clock can be stopped. An external pull-up resistor is required.

Serial Peripheral Interface (SPI) Signals

Name	Type	Description
SPI_CS#	I/O	SPI Chip Select: Also used as the SPI bus request signal.
SPI_MISO	I	SPI Master IN Slave OUT: Data input pin for Intel® ICH7.
SPI_MOSI	O	SPI Master OUT Slave IN: Data output pin for ICH7.
SPI_ARB	I	SPI Arbitration: SPI arbitration signal is used to arbitrate the SPI bus with Intel PRO 82573E Gigabit Ethernet Controller when Shared Flash is implemented.
SPI_CLK	O	SPI Clock: SPI clock signal, during idle the bus owner will drive the clock signal low. 17.86 MHz.

Platform LAN Connect Interface Signals

Name	Type	Description
LAN_CLK	I	LAN I/F Clock: This signal is driven by the Platform LAN Connect component. The frequency range is 5 MHz to 50 MHz.
LAN_RXD[2:0]	I	Received Data: The Platform LAN Connect component uses these signals to transfer data and control information to the integrated LAN controller. These signals have integrated weak pull-up resistors.
LAN_TXD[2:0]	O	Transmit Data: The integrated LAN controller uses these signals to transfer data and control information to the Platform LAN Connect component.
LAN_RSTSYNC	O	LAN Reset/Sync: The Platform LAN Connect component's Reset and Sync signals are multiplexed onto this pin.

Other Clock

Name	Type	Description
CLK14	I	Oscillator Clock: This clock is used for 8254 timers. It runs at 14.31818 MHz. This clock is permitted to stop during S3 (or lower) states.
CLK48	I	48 MHz Clock: This clock is used to run the USB controller. Runs at 48.000 MHz. This clock is permitted to stop during S3 (or lower) states.
SATA_CLKP SATA_CLKN	I	100 MHz Differential Clock: These signals are used to run the SATA controller at 100 MHz. This clock is permitted to stop during S3/S4/S5 states.
DMI_CLKP, DMI_CLKN	I	100 MHz Differential Clock: These signals are used to run the Direct Media Interface. Runs at 100 MHz.

8224 N/B Maintenance

5.2 Intel ICH7-M South Bridge (4)

IDE Interface Signals

Name	Type	Description
DCS1#	O	IDE Device Chip Selects for 100 Range: For ATA command register block. This output signal is connected to the corresponding signal on the IDE connector.
DCS3#	O	IDE Device Chip Select for 300 Range: For ATA control register block. This output signal is connected to the corresponding signal on the IDE connector.
DA[2:0]	O	IDE Device Address: These output signals are connected to the corresponding signals on the IDE connector. They are used to indicate which byte in either the ATA command block or control block is being addressed.
DD[15:0]	I/O	IDE Device Data: These signals directly drive the corresponding signals on the IDE connector. There is a weak internal pull-down resistor on DD7.
DDREQ	I	IDE Device DMA Request: This input signal is directly driven from the DRQ signal on the IDE connector. It is asserted by the IDE device to request a data transfer, and used in conjunction with the PCI bus master IDE function and are not associated with any AT compatible DMA channel. There is a weak internal pulldown resistor on this signal.
DDACK#	O	IDE Device DMA Acknowledge: This signal directly drives the DAK# signal on the IDE connector. DDACK# is asserted by the Intel® ICH7 to indicate to IDE DMA slave devices that a given data transfer cycle (assertion of DIOR# or DIOW#) is a DMA data transfer cycle. This signal is used in conjunction with the PCI bus master IDE function and are not associated with any AT-compatible DMA channel.
DIOR#/ (DWSTB/ RDMARDY#)	O	DIOR# /Disk I/O Read (PIO and Non-Ultra DMA): This is the command to the IDE device that it may drive data onto the DD lines. Data is latched by the ICH7 on the deassertion edge of DIOR#. The IDE device is selected either by the ATA register file chip selects (DCS1# or DCS3#) and the DA lines, or the IDE DMA acknowledge (DDAK#). Disk Write Strobe (Ultra DMA Writes to Disk): This is the data write strobe for writes to disk. When writing to disk, ICH7 drives valid data on rising and falling edges of DWSTB. Disk DMA Ready (Ultra DMA Reads from Disk): This is the DMA ready for reads from disk. When reading from disk, ICH7 deasserts RDMARDY# to pause burst data transfers.

IDE Interface Signals (Continued)

Name	Type	Description
DIOW#/ (DSTOP)	O	Disk I/O Write (PIO and Non-Ultra DMA): This is the command to the IDE device that it may latch data from the DD lines. Data is latched by the IDE device on the deassertion edge of DIOW#. The IDE device is selected either by the ATA register file chip selects (DCS1# or DCS3#) and the DA lines, or the IDE DMA acknowledge (DDAK#). Disk Stop (Ultra DMA): ICH7 asserts this signal to terminate a burst.
IORDY/ (DRSTB/ WDMARDY#)	I	I/O Channel Ready (PIO): This signal will keep the strobe active (DIOR# on reads, DIOW# on writes) longer than the minimum width. It adds wait-states to PIO transfers. Disk Read Strobe (Ultra DMA Reads from Disk): When reading from disk, ICH7 latches data on rising and falling edges of this signal from the disk. Disk DMA Ready (Ultra DMA Writes to Disk): When writing to disk, this is deasserted by the disk to pause burst data transfers.

System Management Interface Signals

Name	Type	Description
INTRUDER#	I	Intruder Detect: This signal can be set to disable system if box detected open. This signal's status is readable, so it can be used like a GPIO if the Intruder Detection is not needed.
SMLINK[1:0]	I/OD	System Management Link: SMBus link to optional external system management ASIC or LAN controller. External pull-ups are required. Note that SMLINK0 corresponds to an SMBus Clock signal, and SMLINK1 corresponds to an SMBus Data signal.
LINKALERT#	I/OD	SMLink Alert: Output of the integrated LAN and input to either the integrated ASF or an external management controller in order for the LAN's SMLINK slave to be serviced.

8224 N/B Maintenance

5.2 Intel ICH7-M South Bridge (5)

USB Interface Signals

Name	Type	Description
USBP0P, USBP0N, USBP1P, USBP1N	I/O	Universal Serial Bus Port [1:0] Differential: These differential pairs are used to transmit Data/Address/Command signals for ports 0 and 1. These ports can be routed to UHCI controller #1 or the EHCI controller. NOTE: No external resistors are required on these signals. The Intel® ICH7 integrates 15 k Ω pull-downs and provides an output driver impedance of 45 Ω which requires no external series resistor.
USBP2P, USBP2N, USBP3P, USBP3N	I/O	Universal Serial Bus Port [3:2] Differential: These differential pairs are used to transmit data/address/command signals for ports 2 and 3. These ports can be routed to UHCI controller #2 or the EHCI controller. NOTE: No external resistors are required on these signals. The ICH7 integrates 15 K Ω pull-downs and provides an output driver impedance of 45 Ω which requires no external series resistor.
USBP4P, USBP4N, USBP5P, USBP5N	I/O	Universal Serial Bus Port [5:4] Differential: These differential pairs are used to transmit Data/Address/Command signals for ports 4 and 5. These ports can be routed to UHCI controller #3 or the EHCI controller. NOTE: No external resistors are required on these signals. The ICH7 integrates 15 K Ω pull-downs and provides an output driver impedance of 45 Ω which requires no external series resistor.
USBP6P, USBP6N, USBP7P, USBP7N	I/O	Universal Serial Bus Port [7:6] Differential: These differential pairs are used to transmit Data/Address/Command signals for ports 6 and 7. These ports can be routed to UHCI controller #4 or the EHCI controller. NOTE: No external resistors are required on these signals. The ICH7 integrates 15 K Ω pull-downs and provides an output driver impedance of 45 Ω which requires no external series resistor.
OC[4:0]# OC5#/GPIO29 OC6#/GPIO30 OC7#/GPIO31	I	Overcurrent Indicators: These signals set corresponding bits in the USB controllers to indicate that an overcurrent condition has occurred. OC[7:4]# may optionally be used as GPIOs. NOTE: OC[7:0]# are not 5 V tolerant.
USBRBIAS	O	USB Resistor Bias: Analog connection point for an external resistor. Used to set transmit currents and internal load resistors.
USBRBIAS#	I	USB Resistor Bias Complement: Analog connection point for an external resistor. Used to set transmit currents and internal load resistors.

EEPROM Interface Signals

Name	Type	Description
EE_SHCLK	O	EEPROM Shift Clock: Serial shift clock output to the EEPROM.
EE_DIN	I	EEPROM Data In: Transfers data from the EEPROM to the Intel® ICH7. This signal has an integrated pull-up resistor.
EE_DOUT	O	EEPROM Data Out: Transfers data from the ICH7 to the EEPROM.
EE_CS	O	EEPROM Chip Select: Chip select signal to the EEPROM.

Interrupt Signals

Name	Type	Description
SERIRQ	I/O	Serial Interrupt Request: This pin implements the serial interrupt protocol.
PIRQ[D:A]#	I/OD	PCI Interrupt Requests: In non-APIC mode the PIRQx# signals can be routed to interrupts 3, 4, 5, 6, 7, 9, 10, 11, 12, 14 or 15 as described in the Interrupt Steering section. Each PIRQx# line has a separate Route Control register. In APIC mode, these signals are connected to the internal I/O APIC in the following fashion: PIRQA# is connected to IRQ16, PIRQB# to IRQ17, PIRQC# to IRQ18, and PIRQD# to IRQ19. This frees the legacy interrupts.
PIRQ[H:E]#/ GPIO[5:2]	I/OD	PCI Interrupt Requests: In non-APIC mode the PIRQx# signals can be routed to interrupts 3, 4, 5, 6, 7, 9, 10, 11, 12, 14 or 15 as described in the <i>Interrupt Steering</i> section. Each PIRQx# line has a separate Route Control register. In APIC mode, these signals are connected to the internal I/O APIC in the following fashion: PIRQE# is connected to IRQ20, PIRQF# to IRQ21, PIRQG# to IRQ22, and PIRQH# to IRQ23. This frees the legacy interrupts. If not needed for interrupts, these signals can be used as GPIO.
IDEIRQ	I	IDE Interrupt Request: This interrupt input is connected to the IDE drive.

8224 N/B Maintenance

5.2 Intel ICH7-M South Bridge (6)

Power Management Interface Signals

Name	Type	Description
PWRBTN#	I	Power Button: The Power Button will cause SMI# or SCI to indicate a system request to go to a sleep state. If the system is already in a sleep state, this signal will cause a wake event. If PWRBTN# is pressed for more than 4 seconds, this will cause an unconditional transition (power button override) to the S5 state. Override will occur even if the system is in the S1-S4 states. This signal has an internal pullup resistor and has an internal 16 ms de-bounce on the input.
RI#	I	Ring Indicate: This signal is an input from a modem. It can be enabled as a wake event, and this is preserved across power failures.
SYS_RESET#	I	System Reset: This pin forces an internal reset after being debounced. The ICH7 will reset immediately if the SMBus is idle; otherwise, it will wait up to 25 ms ± 2 ms for the SMBus to idle before forcing a reset on the system.
LAN_RST#	I	LAN Reset: When asserted, the internal LAN controller will be put into reset. This signal must be asserted for at least 10 ms after the resume well power (VccSus3_3 and VccSus1_5) is valid. When de-asserted, this signal is an indication that the resume well power is stable. NOTE: LAN_RST# should be tied to RSMEST#.
WAKE#	I	PCI Express* Wake Event: Sideband wake signal on PCI Express asserted by components requesting wakeup.
MCH_SYNC#	I	MCH SYNC: This input is internally ANDed with the PWROK input. Connected to the ICH_SYNC# output of (G)MCH.
THRM#	I	Thermal Alarm: Active low signal generated by external hardware to generate an SMI# or SCI.
THRMTRIP#	I	Thermal Trip: When low, this signal indicates that a thermal trip from the processor occurred, and the ICH7 will immediately transition to a S5 state. The ICH7 will not wait for the processor stop grant cycle since the processor has overheated.
SUS_STAT#/ LPCPD#	O	Suspend Status: This signal is asserted by the ICH7 to indicate that the system will be entering a low power state soon. This can be monitored by devices with memory that need to switch from normal refresh to suspend refresh mode. It can also be used by other peripherals as an indication that they should isolate their outputs that may be going to powered-off planes. This signal is called LPCPD# on the LPC I/F.

Power Management Interface Signals (Continued)

Name	Type	Description
SUSCLK	O	Suspend Clock: This clock is an output of the RTC generator circuit to use by other chips for refresh clock.
RSMRST#	I	Resume Well Reset: This signal is used for resetting the resume power plane logic.
VRMPWRGD	I	VRM Power Good: This should be connected to be the processor's VRM Power Good signifying the VRM is stable. This signal is internally ANDed with the PWROK input.
PLTRST#	O	Platform Reset: The Intel® ICH7 asserts PLTRST# to reset devices on the platform (e.g., SIO, FWH, LAN, (G)MCH, IDE, TPM, etc.). The ICH7 asserts PLTRST# during power-up and when S/W initiates a hard reset sequence through the Reset Control register (I/O Register CF9h). The ICH7 drives PLTRST# inactive a minimum of 1 ms after both PWROK and VRMPWRGD are driven high. The ICH7 drives PLTRST# active a minimum of 1 ms when initiated through the Reset Control register (I/O Register CF9h). NOTE: PLTRST# is in the VccSus3_3 well.
SLP_S3#	O	S3 Sleep Control: SLP_S3# is for power plane control. This signal shuts off power to all non-critical systems when in S3 (Suspend To RAM), S4 (Suspend to Disk), or S5 (Soft Off) states.
SLP_S4#	O	S4 Sleep Control: SLP_S4# is for power plane control. This signal shuts power to all non-critical systems when in the S4 (Suspend to Disk) or S5 (Soft Off) state. NOTE: This pin must be used to control the DRAM power to use the ICH7's DRAM power-cycling feature. Refer to Chapter 5.14.10.2 for details.
SLP_S5#	O	S5 Sleep Control: SLP_S5# is for power plane control. This signal is used to shut power off to all non-critical systems when in the S5 (Soft Off) states.
PWROK	I	Power OK: When asserted, PWROK is an indication to the ICH7 that core power has been stable for 99 ms and that PCICLK has been stable for 1 ms. An exception to this rule is if the system is in S3HOT, in which PWROK may or may not stay asserted even though PCICLK may be inactive. PWROK can be driven asynchronously. When PWROK is negated, the ICH7 asserts PLTRST#. NOTE: PWROK must deassert for a minimum of three RTC clock periods for the ICH7 to fully reset the power and properly generate the PLTRST# output.

8224 N/B Maintenance

5.2 Intel ICH7-M South Bridge (7)

Processor Interface Signals

Name	Type	Description
A20M#	O	Mask A20: A20M# will go active based on either setting the appropriate bit in the Port 92h register, or based on the A20GATE input being active.
CPUSLP#	O	CPU Sleep: This signal puts the processor into a state that saves substantial power compared to Stop-Grant state. However, during that time, no snoops occur. The Intel® ICH7 can optionally assert the CPUSLP# signal when going to the S1 state.
FERR#	I	Numeric Coprocessor Error: This signal is tied to the coprocessor error signal on the processor. FERR# is only used if the ICH7 coprocessor error reporting function is enabled in the OIC.CEN register (Chipset Config Registers:Offset 31FFh: bit 1). If FERR# is asserted, the ICH7 generates an internal IRQ13 to its interrupt controller unit. It is also used to gate the IGNNE# signal to ensure that IGNNE# is not asserted to the processor unless FERR# is active. FERR# requires an external weak pull-up to ensure a high level when the coprocessor error function is disabled. NOTE: FERR# can be used in some states for notification by the processor of pending interrupt events. This functionality is independent of the OIC register bit setting.
IGNNE#	O	Ignore Numeric Error: This signal is connected to the ignore error pin on the processor. IGNNE# is only used if the ICH7 coprocessor error reporting function is enabled in the OIC.CEN register (Chipset Config Registers:Offset 31FFh: bit 1). If FERR# is active, indicating a coprocessor error, a write to the Coprocessor Error register (I/O register F0h) causes the IGNNE# to be asserted. IGNNE# remains asserted until FERR# is negated. If FERR# is not asserted when the Coprocessor Error register is written, the IGNNE# signal is not asserted.
INIT#	O	Initialization: INIT# is asserted by the ICH7 for 16 PCI clocks to reset the processor. ICH7 can be configured to support processor Built In Self Test (BIST).
INIT3_3V#	O	Initialization 3.3 V: This is the identical 3.3 V copy of INIT# intended for Firmware Hub.
INTR	O	Processor Interrupt: INTR is asserted by the ICH7 to signal the processor that an interrupt request is pending and needs to be serviced. It is an asynchronous output and normally driven low.

Processor Interface Signals (Continued)

Name	Type	Description
NMI	O	Non-Maskable Interrupt: NMI is used to force a non-Maskable interrupt to the processor. The ICH7 can generate an NMI when either SERR# is asserted or IOCHK# goes active via the SERIRQ# stream. The processor detects an NMI when it detects a rising edge on NMI. NMI is reset by setting the corresponding NMI source enable/disable bit in the NMI Status and Control register (I/O Register 61h).
SMI#	O	System Management Interrupt: SMI# is an active low output synchronous to PCICLK. It is asserted by the ICH7 in response to one of many enabled hardware or software events.
STPCLK#	O	Stop Clock Request: STPCLK# is an active low output synchronous to PCICLK. It is asserted by the ICH7 in response to one of many hardware or software events. When the processor samples STPCLK# asserted, it responds by stopping its internal clock.
RCIN#	I	Keyboard Controller Reset CPU: The keyboard controller can generate INIT# to the processor. This saves the external OR gate with the ICH7's other sources of INIT#. When the ICH7 detects the assertion of this signal, INIT# is generated for 16 PCI clocks. NOTE: The ICH7 will ignore RCIN# assertion during transitions to the S3, S4, and S5 states.
A20GATE	I	A20 Gate: A20GATE is from the keyboard controller. The signal acts as an alternative method to force the A20M# signal active. It saves the external OR gate needed with various other chipsets.
CPUPWRGD/ GPIO49	O	CPU Power Good: This signal should be connected to the processor's PWRGOOD input to indicate when the CPU power is valid. This is an output signal that represents a logical AND of the ICH7's PWROK and VRMPWRGD signals. This signal may optionally be configured as a GPIO.

Firmware Hub Interface Signals

Name	Type	Description
FWH[3:0]/ LAD[3:0]	I/O	Firmware Hub Signals: These signals are multiplexed with the LPC address signals.
FWH4/ LFRAME#	O	Firmware Hub Signals: This signal is multiplexed with the LPC LFRAME# signal.

8224 N/B Maintenance

5.2 Intel ICH7-M South Bridge (8)

General Purpose I/O Signals

Name	Type	Tolerance	Power Well	Description
GPIO49	I/O	V_CPU_IO	V_CPU_IO	Multiplexed with CPUPWRGD
GPIO48	I/O	3.3 V	Core	Multiplexed with GNT4#
GPIO[47:40]	N/A	3.3 V	N/A	Not implemented.
GPIO[39:38]	I/O	3.3 V	Core	Unmultiplexed.
GPIO37	I/O	3.3 V	Core	Multiplexed with SATA3GP.
GPIO36	I/O	3.3 V	Core	Multiplexed with SATA2GP.
GPIO35	I/O	3.3 V	Core	Multiplexed with SATACLKREQ#.
GPIO34	I/O	3.3 V	Core	Unmultiplexed.
GPIO33	I/O	3.3 V	Core	Unmultiplexed.
GPIO32	I/O	3.3 V	Core	Unmultiplexed.
GPIO31	I/O	3.3 V	Resume	Multiplexed with OC7#
GPIO30	I/O	3.3 V	Resume	Multiplexed with OC6#
GPIO29	I/O	3.3 V	Resume	Multiplexed with OC5#
GPIO28	I/O	3.3 V	Resume	Unmultiplexed.
GPIO27	I/O	3.3 V	Resume	Unmultiplexed.
GPIO26	I/O	3.3 V	Resume	Unmultiplexed.
GPIO25	I/O	3.3 V	Resume	Unmultiplexed.
GPIO24	I/O	3.3 V	Resume	Unmultiplexed. Not cleared by CF9h reset event.
GPIO23	I/O	3.3 V	Core	Multiplexed with LDRQ1#
GPIO22	I/O	3.3 V	Core	Multiplexed with REQ4#
GPIO21	I/O	3.3 V	Core	Multiplexed with SATA0GP.
GPIO20	I/O	3.3 V	Core	Unmultiplexed.
GPIO19	I/O	3.3 V	Core	Multiplexed with SATA1GP.
GPIO18	I/O	3.3 V	Core	Unmultiplexed.
GPIO17	I/O	3.3 V	Core	Multiplexed with GNT5#.
GPIO16	I/O	3.3 V	Core	Unmultiplexed.
GPIO[15:12]	I/O	3.3 V	Resume	Unmultiplexed.
GPIO11	I/O	3.3 V	Resume	Multiplexed with SMBALERT#
GPIO[10:8]	I/O	3.3 V	Resume	Unmultiplexed.
GPIO[7:6]	I/O	3.3 V	Core	Unmultiplexed.
GPIO[5:2]	I/OD	5 V	Core	Multiplexed with PIRQ[H:E]#.

General Purpose I/O Signals (Continued)

Name	Type	Tolerance	Power Well	Description
GPIO1	I/O	5 V	Core	Multiplexed with REQ5#.
GPIO0	I/O	3.3 V	Core	Unmultiplexed.

NOTES:

1. GPI[15:0] can be configured to cause a SMI# or SCI. Note that a GPI can be routed to either an SMI# or an SCI, but not both.
2. Some GPIOs exist in the VccSus3_3 power plane. Care must be taken to make sure GPIO signals are not driven high into powered-down planes. Some ICH7 GPIOs may be connected to pins on devices that exist in the core well. If these GPIOs are outputs, there is a danger that a loss of core power (PWROK low) or a Power Button Override event will result in the Intel ICH7 driving a pin to a logic 1 to another device that is powered down..

PCI Express* Signals

Name	Type	Description
PETp[1:4], PETn[1:4]	O	PCI Express* Differential Transmit Pair 1:4
PERp[1:4], PERn[1:4]	I	PCI Express Differential Receive Pair 1:4
PETp[5:6], PETn[5:6] (Intel® ICH7R Only)	O	PCI Express* Differential Transmit Pair 5:6 Reserved: ICH7
PERp[1:4], PERn[5:6] (ICH7R Only)	I	PCI Express Differential Receive Pair 5:6 Reserved: ICH7

SM Bus Interface Signals

Name	Type	Description
SMBDATA	I/OD	SMBus Data: External pull-up resistor is required.
SMBCLK	I/OD	SMBus Clock: External pull-up resistor is required.
SMBALERT#/ GPIO11	I	SMBus Alert: This signal is used to wake the system or generate SMI#. If not used for SMBALERT#, it can be used as a GPIO.

8224 N/B Maintenance

5.2 Intel ICH7-M South Bridge (9)

AC'97/Intel® High Definition Auto Link Signals

Name	Type	Description
ACZ_RST#	O	AC'97/Intel® High Definition Audio Reset: Master hardware reset to external codec(s).
ACZ_SYNC	O	AC '97/Intel High Definition Audio Sync: 48 kHz fixed rate sample sync to the codec(s). Also used to encode the stream number.
ACZ_BIT_CLK	I/O	AC '97 Bit Clock Input: 12.288 MHz serial data clock generated by the external codec(s). This signal has an integrated pull-down resistor (see Note below). Intel High Definition Audio Bit Clock Output: 24.000 MHz serial data clock generated by the Intel High Definition Audio controller (the Intel® ICH7). This signal has an integrated pull-down resistor so that ACZ_BIT_CLK doesn't float when an Intel High Definition Audio codec (or no codec) is connected but the signals are temporarily configured as AC '97.
ACZ_SDOUT	O	AC '97/Intel High Definition Audio Serial Data Out: Serial TDM data output to the codec(s). This serial output is double-pumped for a bit rate of 48 Mb/s for Intel High Definition Audio. NOTE: ACZ_SDOUT is sampled at the rising edge of PWROK as a functional strap. See Function Straps for more details. There is a weak integrated pull-down resistor on the ACZ_SDOUT pin.
ACZ_SDIN[2:0]	I	AC '97/Intel High Definition Audio Serial Data In [2:0]: Serial TDM data inputs from the three codecs. The serial input is single-pumped for a bit rate of 24 Mb/s for Intel® High Definition Audio. These signals have integrated pulldown resistors, which are always enabled.

LPC Interface Signals

Name	Type	Description
LAD[3:0]/FWH[3:0]	I/O	LPC Multiplexed Command, Address, Data: For LAD[3:0], internal pull-ups are provided.
LFRAME#/FWH4	O	LPC Frame: LFRAME# indicates the start of an LPC cycle, or an abort.
LDRQ[0]#/LDRQ[1]#/GPIO23	I	LPC Serial DMA/Master Request Inputs: LDRQ[1:0]# are used to request DMA or bus master access. These signals are typically connected to external Super I/O device. An internal pull-up resistor is provided on these signals. LDRQ1# may optionally be used as GPIO.

Power and Ground Signals

Name	Description
Vcc3_3	3.3 V supply for core well I/O buffers (22 pins). This power may be shut off in S3, S4, S5 or G3 states.
Vcc1_05	1.05 V supply for core well logic (20 pins). This power may be shut off in S3, S4, S5 or G3 states.
Vcc1_5_A	1.5 V supply for Logic and I/O (30 pins). This power may be shut off in S3, S4, S5 or G3 states.
Vcc1_5_B	1.5 V supply for Logic and I/O (53 pins). This power may be shut off in S3, S4, S5 or G3 states.
V5REF	Reference for 5 V tolerance on core well inputs (2 pins). This power may be shut off in S3, S4, S5 or G3 states.
VccSus3_3	3.3 V supply for resume well I/O buffers (24 pins). This power is not expected to be shut off unless the system is unplugged in desktop configurations.
VccSus1_05	1.05 V supply for resume well logic (5 pins). This power is not expected to be shut off unless the system is unplugged in desktop configurations. This voltage may be generated internally (see Function Straps for strapping option). If generated internally, these pins should not be connected to an external supply.
V5REF_Sus	Reference for 5 V tolerance on resume well inputs (1 pin). This power is not expected to be shut off unless the system is unplugged in desktop configurations.
VccRTC	3.3 V (can drop to 2.0 V min. in G3 state) supply for the RTC well (1 pin). This power is not expected to be shut off unless the RTC battery is removed or completely drained. Note: Implementations should not attempt to clear CMOS by using a jumper to pull VccRTC low. Clearing CMOS in an Intel® ICH7-based platform can be done by using a jumper on RTCRST# or GPI.
VccUSBPLL	1.5 V supply for core well logic (1 pin). This signal is used for the USB PLL. This power may be shut off in S3, S4, S5 or G3 states. Must be powered even if USB not used.
VccDMIPLL	1.5 V supply for core well logic (1 pins). This signal is used for the DMI PLL. This power may be shut off in S3, S4, S5 or G3 states.
VccSATAPLL	1.5 V supply for core well logic (1 pins). This signal is used for the SATA PLL. This power may be shut off in S3, S4, S5 or G3 states. Must be powered even if SATA not used.
V_CPU_IO	Powered by the same supply as the processor I/O voltage (3 pins). This supply is used to drive the processor interface signals listed in Process Interface Signals .
Vss	Grounds (194 pins).

8224 N/B Maintenance

5.2 Intel ICH7-M South Bridge (10)

Functional Strap Definitions

Signal	Usage	When Sampled	Description
GNT3#	Top-Block Swap Override	Rising Edge of PWROK	The signal has a weak internal pull-up. If the signal is sampled low, this indicates that the system is strapped to the “top-block swap” mode (Intel® ICH7 inverts A16 for all cycles targeting FWH BIOS space). The status of this strap is readable via the Top Swap bit (Chipset Config Registers:Offset 3414h:bit 0). Note that software will not be able to clear the Top-Swap bit until the system is rebooted without GNT3# being pulled down.
GNT2#	Reserved		This signal has a weak internal pull-up. NOTE: This signal should not be pulled low.
REQ[4:1]#	XOR Chain Selection	Rising Edge of PWROK	See Chapter 25 for functionality information.
LINKALERT#	Reserved		This signal requires an external pull-up resistor.
SPKR	No Reboot	Rising Edge of PWROK	The signal has a weak internal pull-down. If the signal is sampled high, this indicates that the system is strapped to the “No Reboot” mode (ICH7 will disable the TCO Timer system reboot feature). The status of this strap is readable via the NO REBOOT bit (Chipset Config Registers:Offset 3410h:bit 5).
INTVRMEN	Integrated VccSus1_05 VRM Enable/Disable	Always	Enables integrated VccSus1_05 VRM when sampled high.
EE_CS	Reserved		This signal has a weak internal pull-down. NOTE: This signal should not be pulled high.
EE_DOUT	Reserved		This signal has a weak internal pull-up. NOTE: This signal should not be pulled low.
GNT5#/ GPIO17#, GNT4#/ GPIO48	Boot BIOS Destination Selection	Rising Edge of PWROK	This field determines the destination of accesses to the BIOS memory range. Signals have weak internal pull-ups. Also controllable via Boot BIOS Destination bit (Chipset Config Registers:Offset 3410h:bit 11:10) (GNT5# is MSB) 01-SPI 10-PCI 11-LPC

Functional Strap Definitions (Continued)

Signal	Usage	When Sampled	Description
ACZ_SDOU T	XOR Chain Entrance/PCI Express* Port Config bit 1	Rising Edge of PWROK	Allows entrance to XOR Chain testing when TP3 pulled low at rising edge of PWROK. See Chapter 25 for XOR Chain functionality information. When TP3 not pulled low at rising edge of PWROK, sets bit 1 of RPC.PC (Chipset Config Registers:Offset 224h). See Section 7.1.34 for details. This signal has a weak internal pull-down.
ACZ_SYNC	PCI Express Port Config bit 0	Rising Edge of PWROK	This signal has a weak internal pull-down. Sets bit 0 of RPC.PC (Chipset Config Registers:Offset 224h). See Section 7.1.34 for details.
GPIO25	Reserved	Rising Edge of RSMRST#	This signal has a weak internal pull-up. NOTE: This signal should not be pulled low.
GPIO16	Reserved		This signal has a weak internal pull-down. NOTE: This signal should not be pulled high.
SATALED#	Reserved		This signal has a weak internal pull-up enabled only when PLTRST# is asserted. NOTE: This signal should not be pulled low.
TP3	XOR Chain Entrance	Rising Edge of PWROK	See Chapter 25 for functionality information. This signal has a weak internal pull-up. NOTE: This signal should not be pulled low unless using XOR Chain testing.

Direct Media Interface Signals

Name	Type	Description
DMI[0:3]TXP, DMI[0:3]TXN	O	Direct Media Interface Differential Transmit Pair 0:3
DMI[0:3]RXP, DMI[0:3]RXN	I	Direct Media Interface Differential Receive Pair 0:3
DMI_ZCOMP	O	Impedance Compensation Input: Determines DMI input impedance.
DMI_IRCOMP	I	Impedance/Compensation Compensation Output: Determines DMI output impedance and bias current.

8224 N/B Maintenance

5.2 Intel ICH7-M South Bridge (11)

Miscellaneous Signals

Name	Type	Description
INTVRMEN	I	Internal Voltage Regulator Enable: This signal enables the internal 1.05 V Suspend regulator when connected to VccRTC. When connected to Vss, the internal regulator is disabled.
SPKR	O	Speaker: The SPKR signal is the output of counter 2 and is internally “ANDed” with Port 61h bit 1 to provide Speaker Data Enable. This signal drives an external speaker driver device, which in turn drives the system speaker. Upon PLTRST#, its output state is 0. NOTE: SPKR is sampled at the rising edge of PWROK as a functional strap. See Function Straps for more details. There is a weak integrated pull-down resistor on SPKR pin.
RTCRST#	I	RTC Reset: When asserted, this signal resets register bits in the RTC well. NOTES: 1. Unless CMOS is being cleared (only to be done in the G3 power state), the RTCRST# input must always be high when all other RTC power planes are on. 2. In the case where the RTC battery is dead or missing on the platform, the RTCRST# pin must rise before the RSMRST# pin.
TP0	I	Test Point 0: This signal must have an external pull-up to VccSus3_3.
TP1	O	Test Point 1: Route signal to a test point.
TP2	O	Test Point 2: Route signal to a test point.
TP3	I/O	Test Point 3: Route signal to a test point.

Real Time Clock Interface

Name	Type	Description
RTCX1	Special	Crystal Input 1: This signal is connected to the 32.768 KHz crystal. If no external crystal is used, then RTCX1 can be driven with the desired clock rate.
RTCX2	Special	Crystal Input 2: This signal is connected to the 32.768 KHz crystal. If no external crystal is used, then RTCX2 should be left floating.

8224 N/B Maintenance

6. System Block Diagram

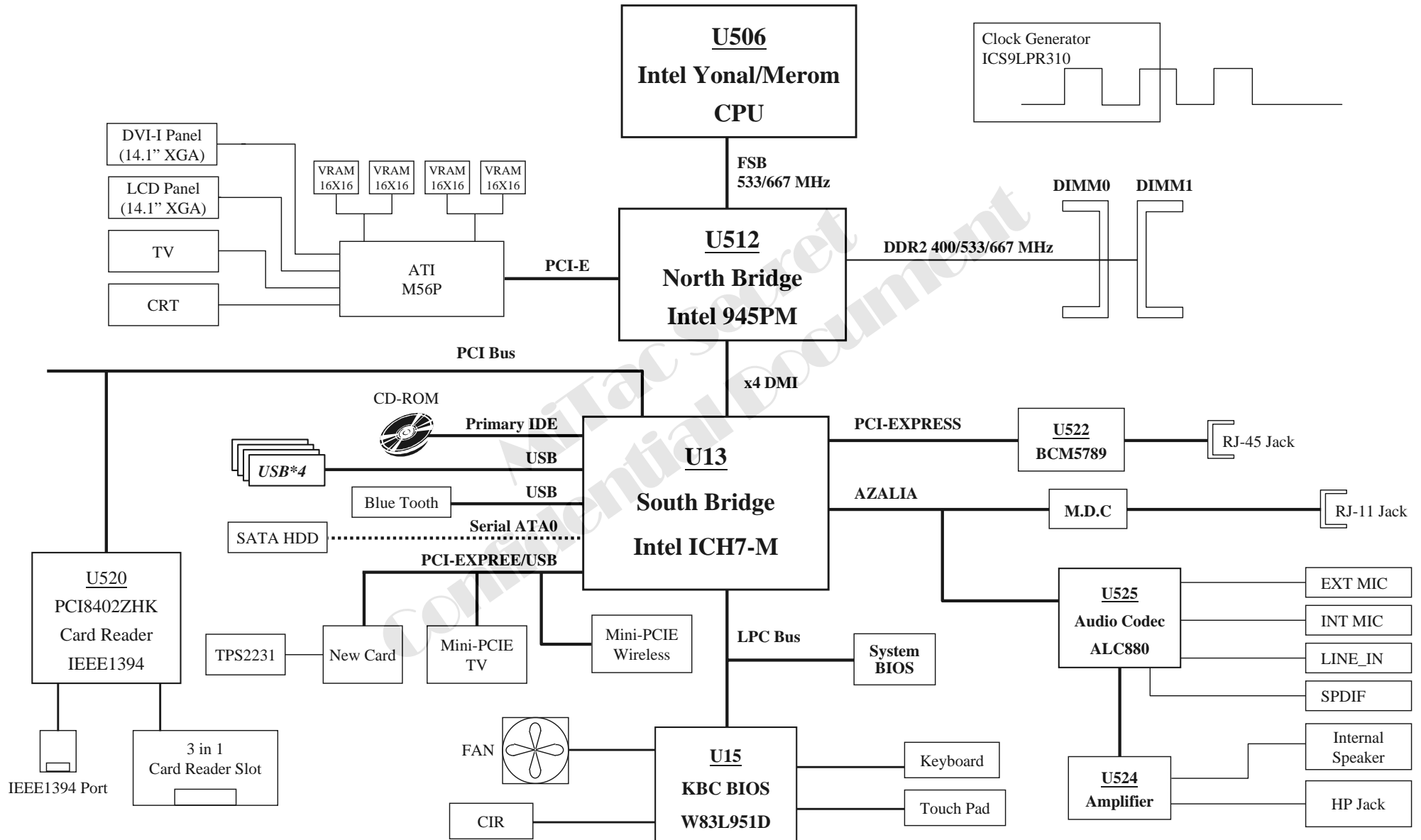

8224 N/B Maintenance

7. Maintenance Diagnostics

7.1 Introduction

Each time the computer is turned on, the system bios runs a series of internal checks on the hardware. This power-on self test (post) allows the computer to detect problems as early as the power-on stage. Error messages of post can alert you to the problems of your computer.

If an error is detected during these tests, you will see an error message displayed on the screen. If the error occurs before the display is initialized, then the screen cannot display the error message. Error codes or system beeps are used to identify a post error that occurs when the screen is not available.

The value for the diagnostic port is written at the beginning of the test. Therefore, if the test failed, the user can determine where the problem occurred by reading the last value written to port by the debug card.

Confidential Document

8224 N/B Maintenance

7.2 Error Codes (1)

Following is a list of error codes in sequent display on the debug card.

Code	POST Routine Description
0x21	EFI_COMPUTING_UNIT_CHIPSET EFI_CU_PC_INIT_BEGIN
0x22	EFI_COMPUTING_UNIT_MEMORY EFI_CU_MEMORY_PC_SPD_READ
0x23	EFI_COMPUTING_UNIT_MEMORY EFI_CU_MEMORY_PC_PRESENCE_DETECT
0x24	EFI_COMPUTING_UNIT_MEMORY EFI_CU_MEMORY_PC_TIMING
0x25	EFI_COMPUTING_UNIT_MEMORY EFI_CU_MEMORY_PC_CONFIGURING
0x26	EFI_COMPUTING_UNIT_MEMORY EFI_CU_MEMORY_PC_OPTIMIZING
0x27	EFI_COMPUTING_UNIT_MEMORY EFI_CU_MEMORY_PC_INIT
0x28	EFI_COMPUTING_UNIT_MEMORY EFI_CU_MEMORY_PC_TEST
0x30	EFI_SOFTWARE_PEI_MODULE EFI_SW_PEIM_PC_RECOVERY_BEGIN
0x31	EFI_SOFTWARE_PEI_MODULE EFI_SW_PEIM_PC_RECOVERY_AUTO
0x34	EFI_SOFTWARE_PEI_MODULE EFI_SW_PEIM_PC_CAPSULE_LOAD
0x35	EFI_SOFTWARE_PEI_MODULE EFI_SW_PEIM_PC_CAPSULE_START
0x3F	EFI_SOFTWARE_PEI_MODULE EFI_SW_PEIM_EC_NO_RECOVERY_CAPSULE
0x10	EFI_COMPUTING_UNIT_HOST_PROCESSOR EFI_CU_HP_PC_POWER_ON_INIT
0x11	EFI_COMPUTING_UNIT_HOST_PROCESSOR EFI_CU_HP_PC_CACHE_INIT
0x12	EFI_COMPUTING_UNIT_HOST_PROCESSOR EFI_CU_HP_PC_AP_INIT
0x13	EFI_COMPUTING_UNIT_HOST_PROCESSOR EFI_CU_HP_PC_SMM_INIT
0x50	EFI_IO_BUS_PCI EFI_IOB_PCI_PC_BUS_ENUM
0x51	EFI_IO_BUS_PCI EFI_IOB_PCI_PC_RES_ALLOC
0x52	EFI_IO_BUS_PCI EFI_IOB_PCI_PC_HPC_INIT
0x58	EFI_IO_BUS_USB EFI_IOB_PC_RESET
0x5A	EFI_IO_BUS_ATA_ATAPI EFI_IOB_PC_RESET
0x5C	EFI_IO_BUS_SMBUS EFI_IOB_PC_RESET

8224 N/B Maintenance

7.2 Error Codes (2)

Following is a list of error codes in sequent display on the debug card.

Code	POST Routine Description
0x70	EFI_PERIPHERAL_LOCAL_CONSOLE EFI_P_PC_RESET
0x71	EFI_PERIPHERAL_LOCAL_CONSOLE EFI_P_PC_DISABLE
0x72	EFI_PERIPHERAL_LOCAL_CONSOLE EFI_P_PC_ENABLE
0x78	EFI_PERIPHERAL_REMOTE_CONSOLE EFI_P_PC_RESET
0x79	EFI_PERIPHERAL_REMOTE_CONSOLE EFI_P_PC_DISABLE
0x7A	EFI_PERIPHERAL_REMOTE_CONSOLE EFI_P_PC_ENABLE
0x90	EFI_PERIPHERAL_KEYBOARD EFI_P_PC_RESET
0x91	EFI_PERIPHERAL_KEYBOARD EFI_P_PC_DISABLE
0x92	EFI_PERIPHERAL_KEYBOARD EFI_P_PC_PRESENCE_DETECT
0x93	EFI_PERIPHERAL_KEYBOARD EFI_P_PC_ENABLE
0x94	EFI_PERIPHERAL_KEYBOARD EFI_P_KEYBOARD_PC_CLEAR_BUFFER
0x95	EFI_PERIPHERAL_KEYBOARD EFI_P_KEYBOARD_PC_SELF_TEST
0x98	EFI_PERIPHERAL_MOUSE EFI_P_PC_RESET
0x99	EFI_PERIPHERAL_MOUSE EFI_P_PC_DISABLE
0x9A	EFI_PERIPHERAL_MOUSE EFI_P_PC_PRESENCE_DETECT
0x9B	EFI_PERIPHERAL_MOUSE EFI_P_PC_ENABLE
0xB0	EFI_PERIPHERAL_FIXED_MEDIA EFI_P_PC_RESET
0xB1	EFI_PERIPHERAL_FIXED_MEDIA EFI_P_PC_DISABLE
0xB2	EFI_PERIPHERAL_FIXED_MEDIA EFI_P_PC_PRESENCE_DETECT
0xB3	EFI_PERIPHERAL_FIXED_MEDIA EFI_P_PC_ENABLE
0xB8	EFI_PERIPHERAL_REMOVABLE_MEDIA EFI_P_PC_RESET
0xB9	EFI_PERIPHERAL_REMOVABLE_MEDIA EFI_P_PC_DISABLE
0xBA	EFI_PERIPHERAL_REMOVABLE_MEDIA EFI_P_PC_PRESENCE_DETECT

8224 N/B Maintenance

7.2 Error Codes (3)

Following is a list of error codes in sequent display on the debug card.

Code	POST Routine Description
0xBB	EFI_PERIPHERAL_REMOVABLE_MEDIA EFI_P_PC_ENABLE
0xE0	EFI_SOFTWARE_PEI_CORE EFI_SW_PC_INIT_BEGIN
0x00	EFI_SOFTWARE_PEI_CORE EFI_SW_PC_INIT_END
0xE4	EFI_SOFTWARE_DXE_CORE EFI_SW_DXE_CORE_PC_ENTRY_POINT
0xE5	EFI_SOFTWARE_DXE_CORE EFI_SW_PC_INIT_BEGIN
0xE6	EFI_SOFTWARE_DXE_CORE EFI_SW_DXE_CORE_PC_START_DRIVER
0xE7	EFI_SOFTWARE_DXE_BS_DRIVER EFI_SW_PC_INPUT_WAIT
0xE9	EFI_SOFTWARE_DXE_BS_DRIVER EFI_SW_PC_USER_SETUP
0xEB	EFI_SOFTWARE_DXE_BS_DRIVER EFI_SW_DXE_BS_PC_LEGACY_OPROM_INIT
0xF8	EFI_SOFTWARE_EFI_BOOT_SERVICE EFI_SW_BS_PC_EXIT_BOOT_SERVICES
0xF9	EFI_SOFTWARE_EFI_BOOT_SERVICE EFI_SW_RS_PC_SET_VIRTUAL_ADDRESS_MAP
0xFA	EFI_SOFTWARE_EFI_BOOT_SERVICE EFI_SW_RS_PC_RESET_SYSTEM

Confidential

8224 N/B Maintenance

7.3 Debug Tool



8224 N/B Maintenance

8. Trouble Shooting

- 8.1 No Power (*1)
- 8.2 No Display (*2)
- 8.3 TV Out Test Error
- 8.4 VGA Controller Test Error LCD No Display
- 8.5 External Monitor No Display
- 8.6 Memory Test Error
- 8.7 Keyboard (K/B) or Touch-Pad (T/P) Test Error
- 8.8 Hard Drive Test Error
- 8.9 CD-ROM Drive Test Error
- 8.10 USB Port Test Error
- 8.11 New Card Test Error
- 8.12 Blue Tooth Test Error
- 8.13 Mini-PCI Socket Test Error
- 8.14 CardReader & IEEE1394 Socket Test Error
- 8.15 Audio Test Error
- 8.16 LAN Test Error

8224 N/B Maintenance

***1: No Power Definition**

Base on ACPI Spec. We define the no power as while we press the power button, the system can't leave S5 status or none the PG signal send out from power supply.

Judge condition:

- Check whether there are any voltage feedback control to turn off the power
- Check whether no CPU power will cause system can't leave S5 status

If there are not any diagram match these condition, we should stop analyzing the schematic in power supply sending out the PG signal. If yes, we should add the effected analysis into no power chapter.

***2: No Display Definition**

Base on the digital IC three basic working conditions: working power, reset, Clock. We define the no display as while system leave S5 status but can't get into S0 status.

Judge condition:

- Check which power will cause no display
- Check which reset signal will cause no display
- Check which Clock signal will cause no display

Base on these three conditions to analyze the schematic and edit the no display chapter.

Keyword:

- S5: *Soft Off*
- S0: *Working*

For detail please refer the ACPI specification.

8224 N/B Maintenance

8.1 No Power-1

When the power button is pressed, nothing happens, no fan activity is heard and power indicator is not light up.

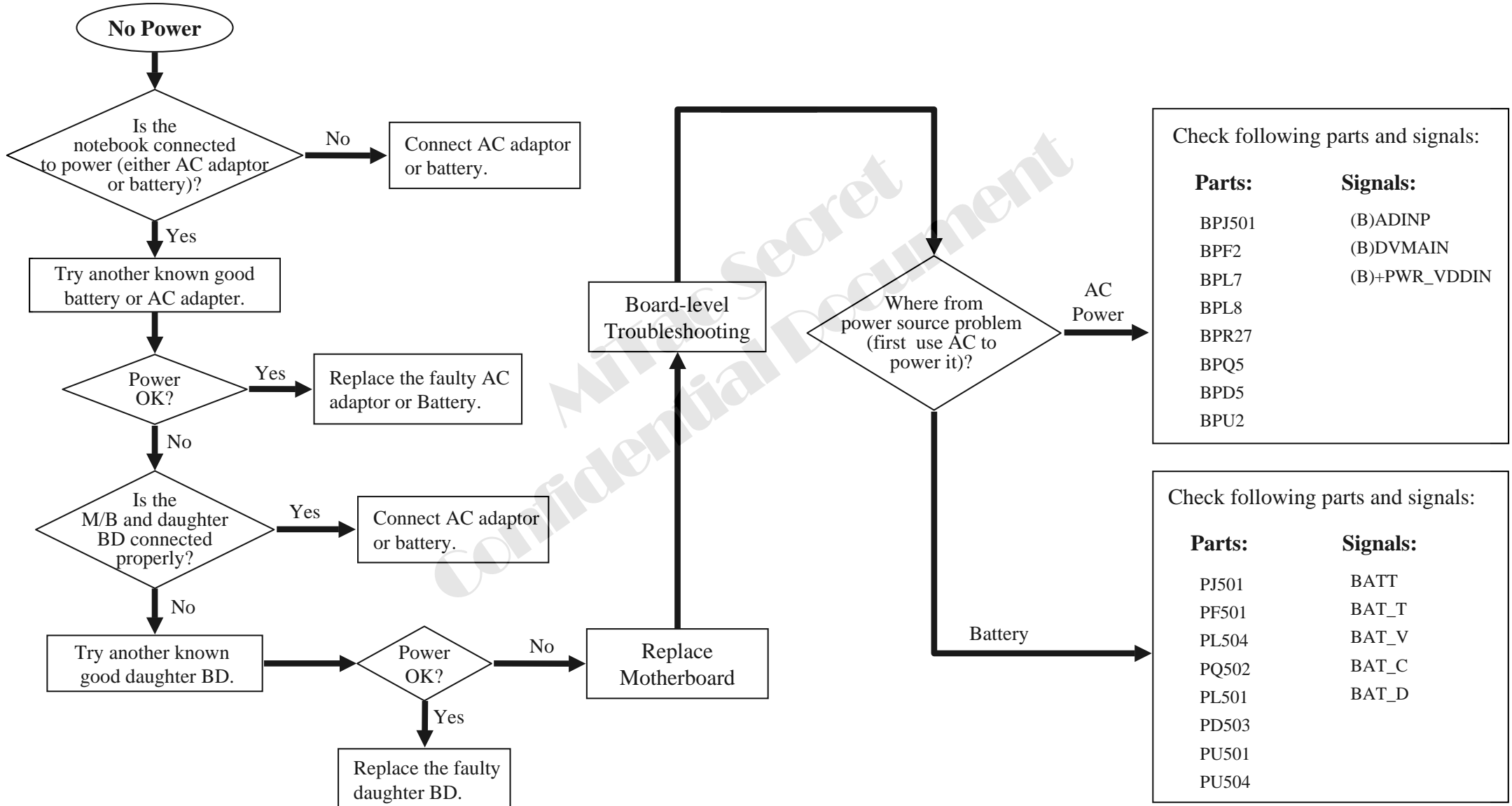

8224 N/B Maintenance

8.1 No Power-2

When the power button is pressed, nothing happens, no fan activity is heard and power indicator is not light up.

Main Voltage Map

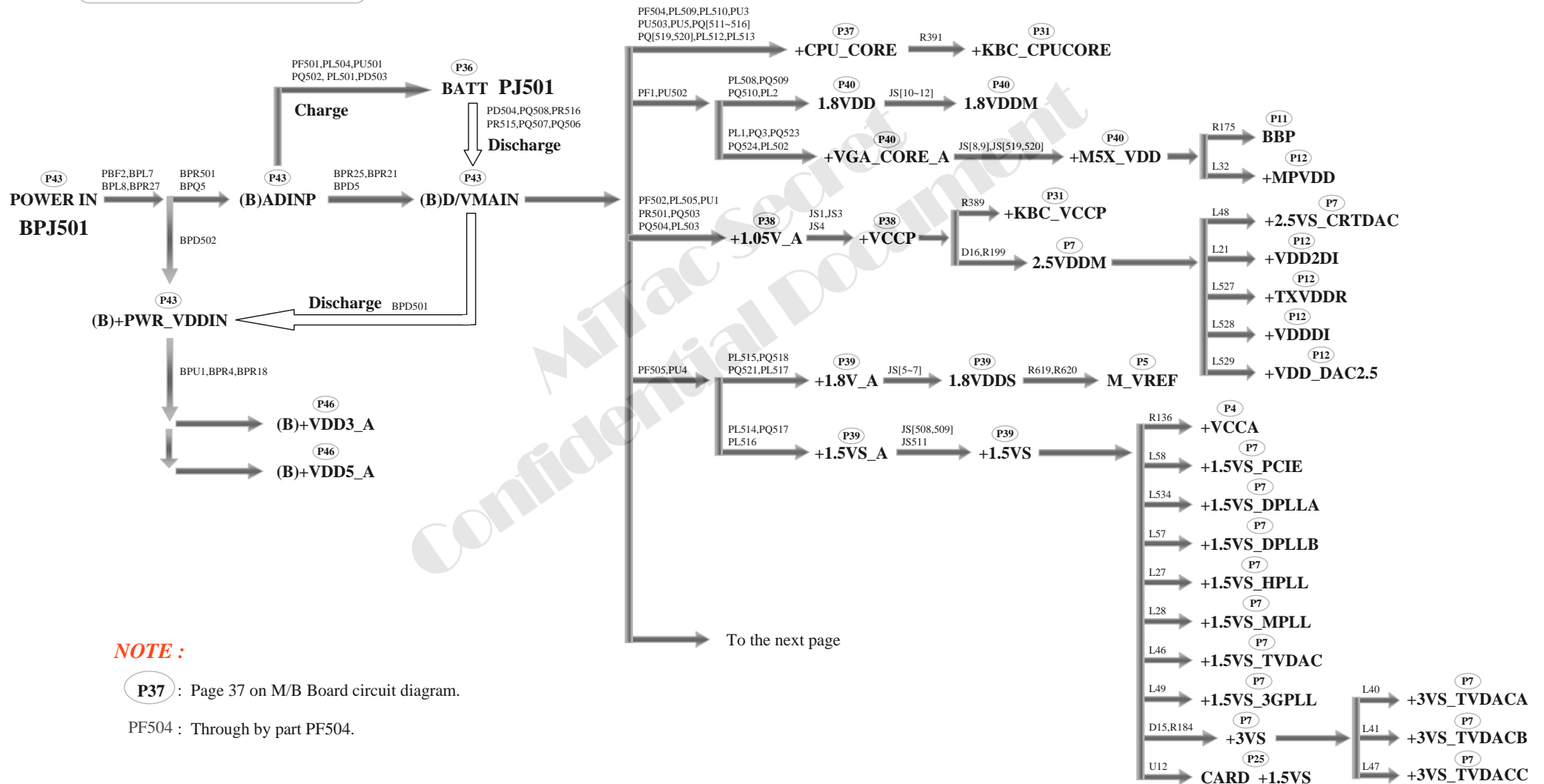

NOTE :

P37 : Page 37 on M/B Board circuit diagram.

PF504 : Through by part PF504.

8224 N/B Maintenance

8.1 No Power-3

When the power button is pressed, nothing happens, no fan activity is heard and power indicator is not light up.

Continue to the previous page

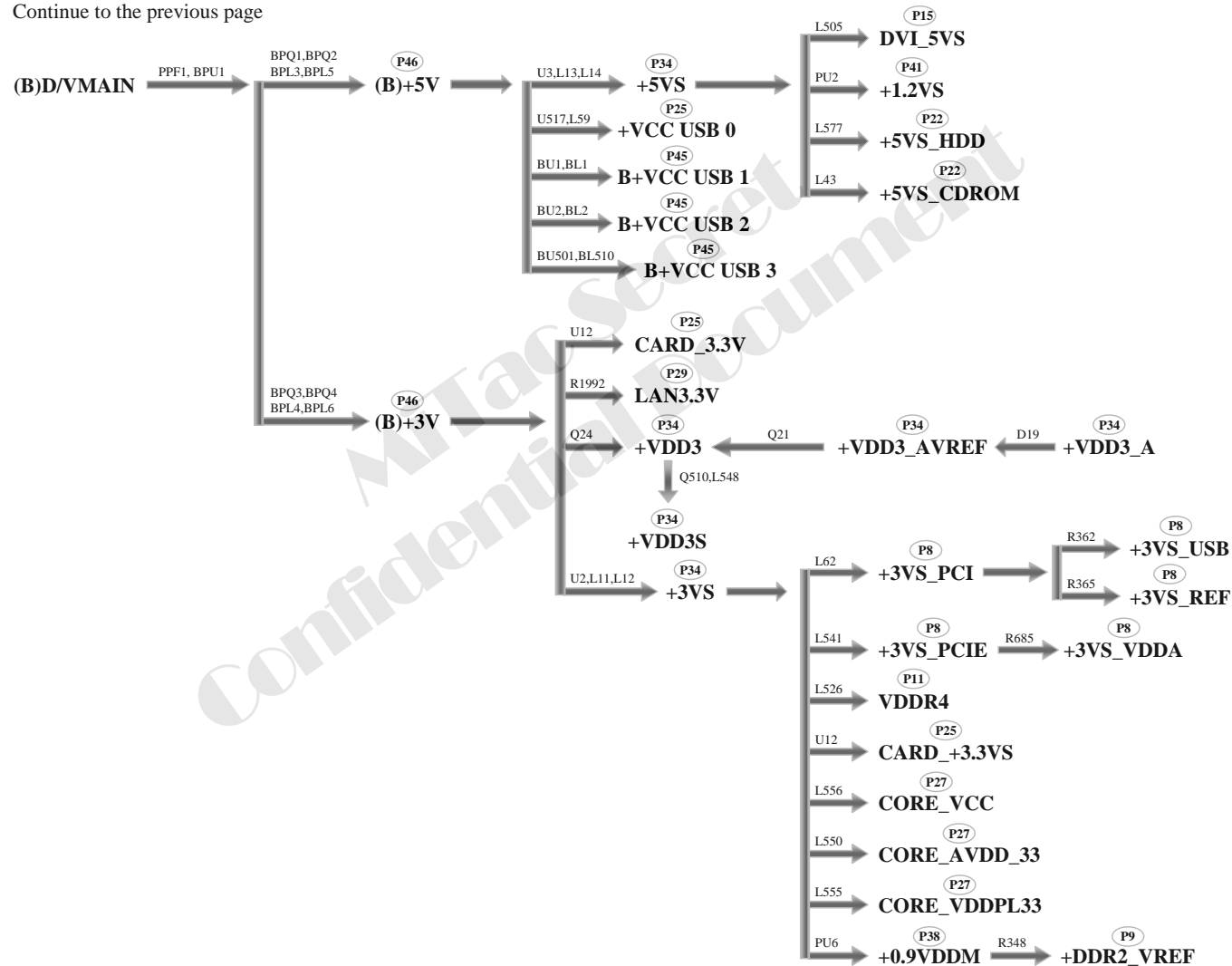

8224 N/B Maintenance

8.1 No Power-4

When the power button is pressed, nothing happens, no fan activity is heard and power indicator is not light up.

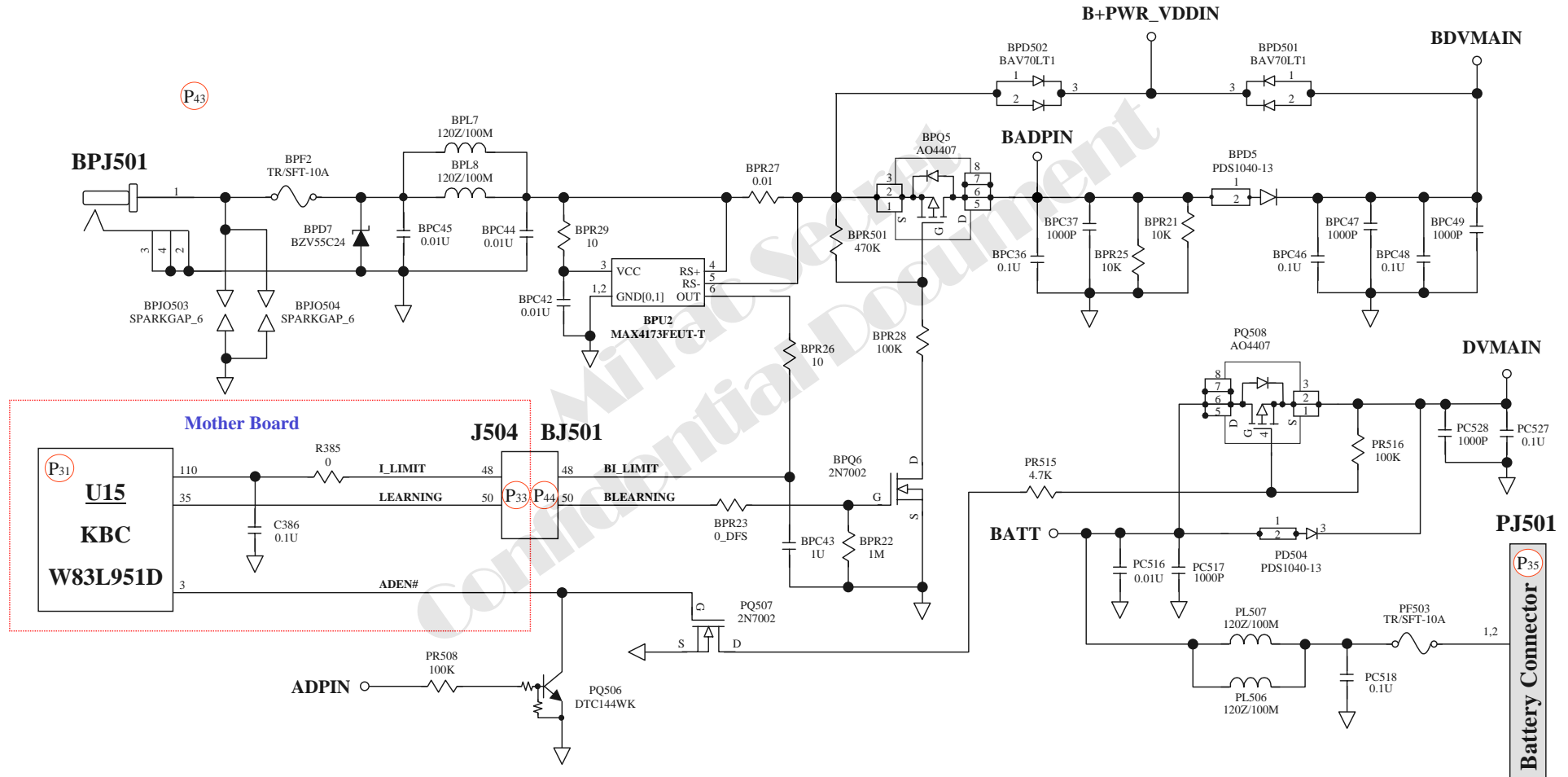

8224 N/B Maintenance

8.1 No Power-5

When the power button is pressed, nothing happens, no fan activity is heard and power indicator is not light up.

Charge

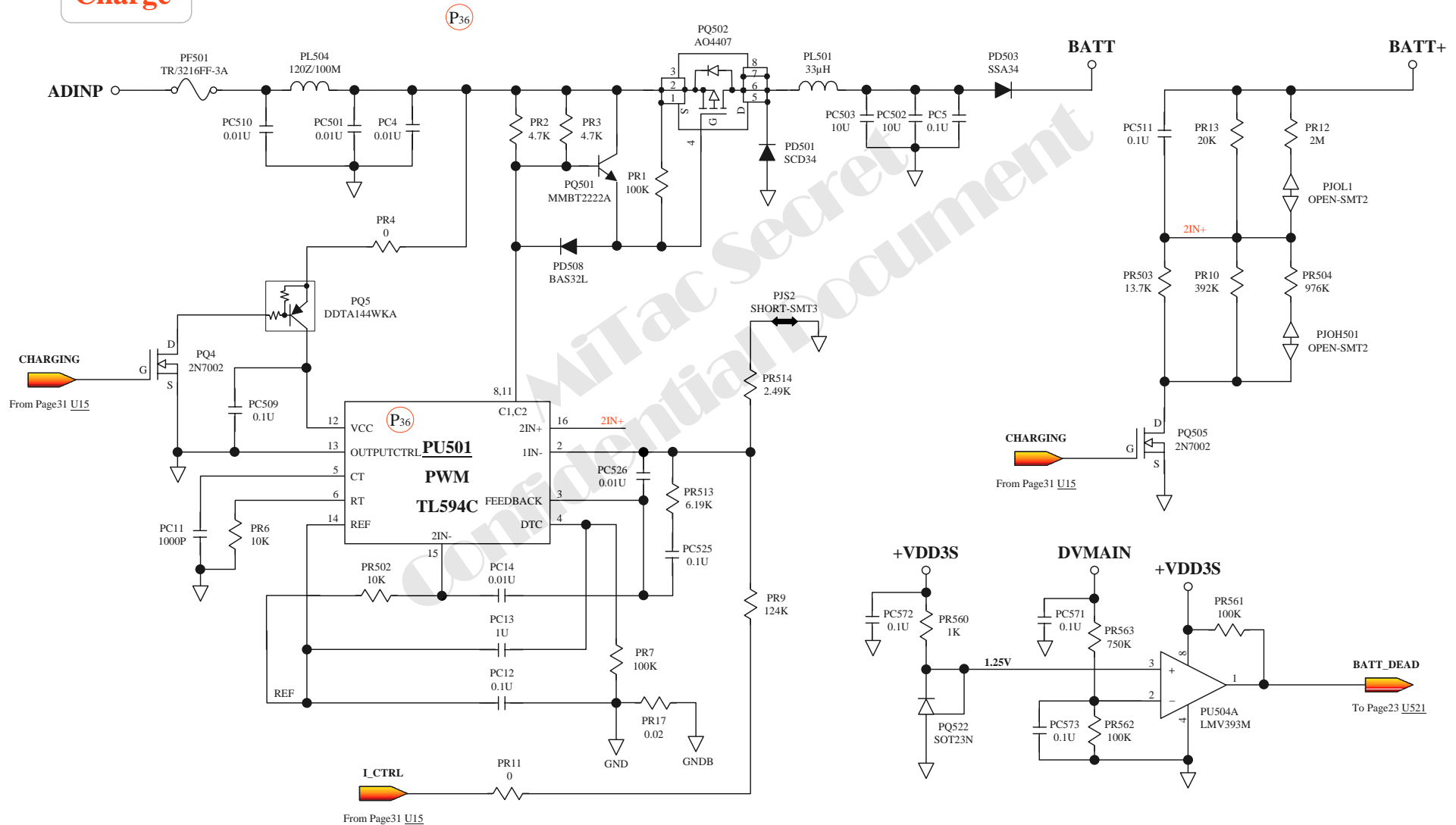

8224 N/B Maintenance

8.1 No Power-6

When the power button is pressed, nothing happens, no fan activity is heard and power indicator is not light up.

Discharge

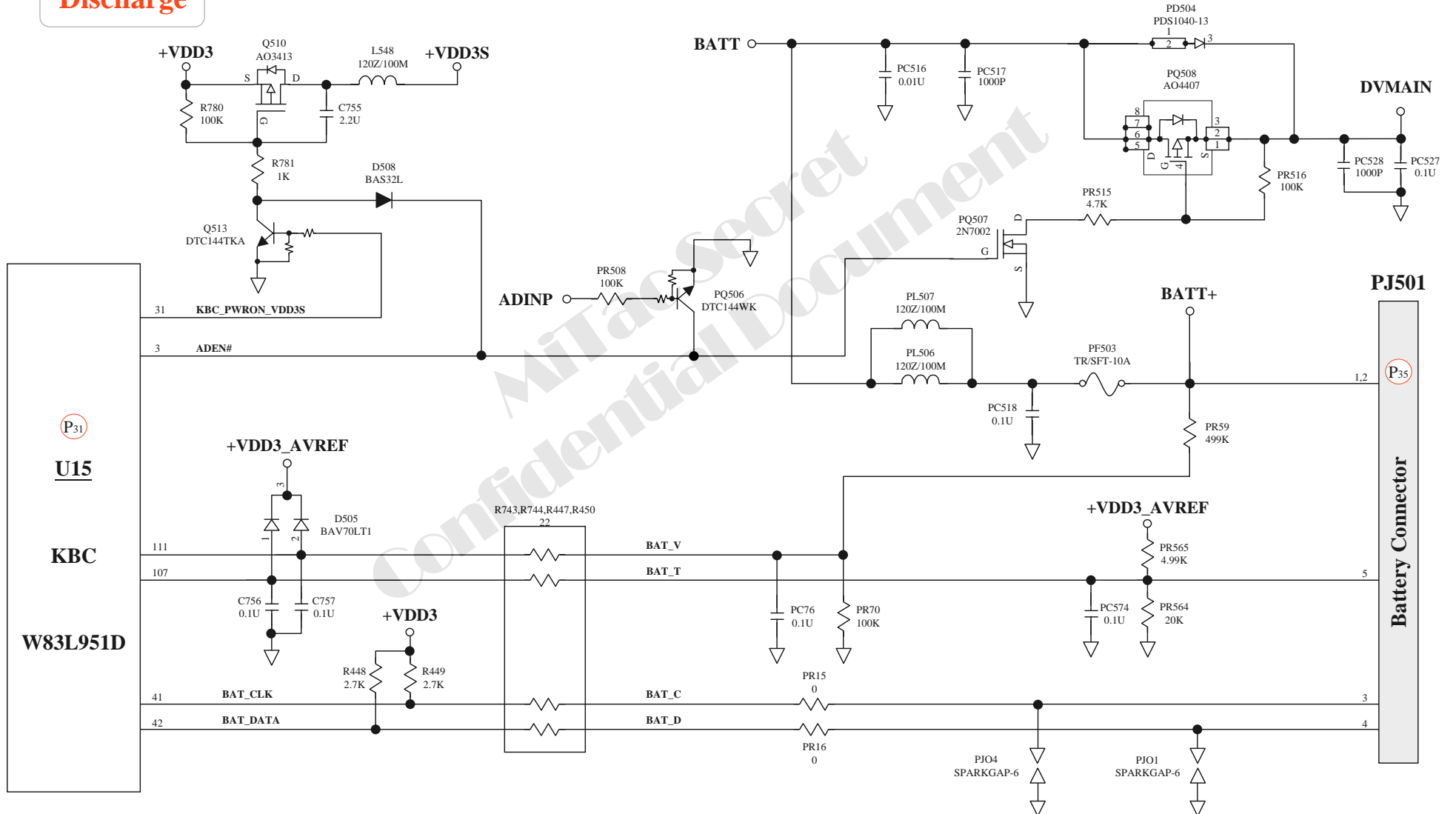

8224 N/B Maintenance

8.2 No Display-1

There is no display on both LCD and VGA monitor after power on although the LCD and monitor is known-good.

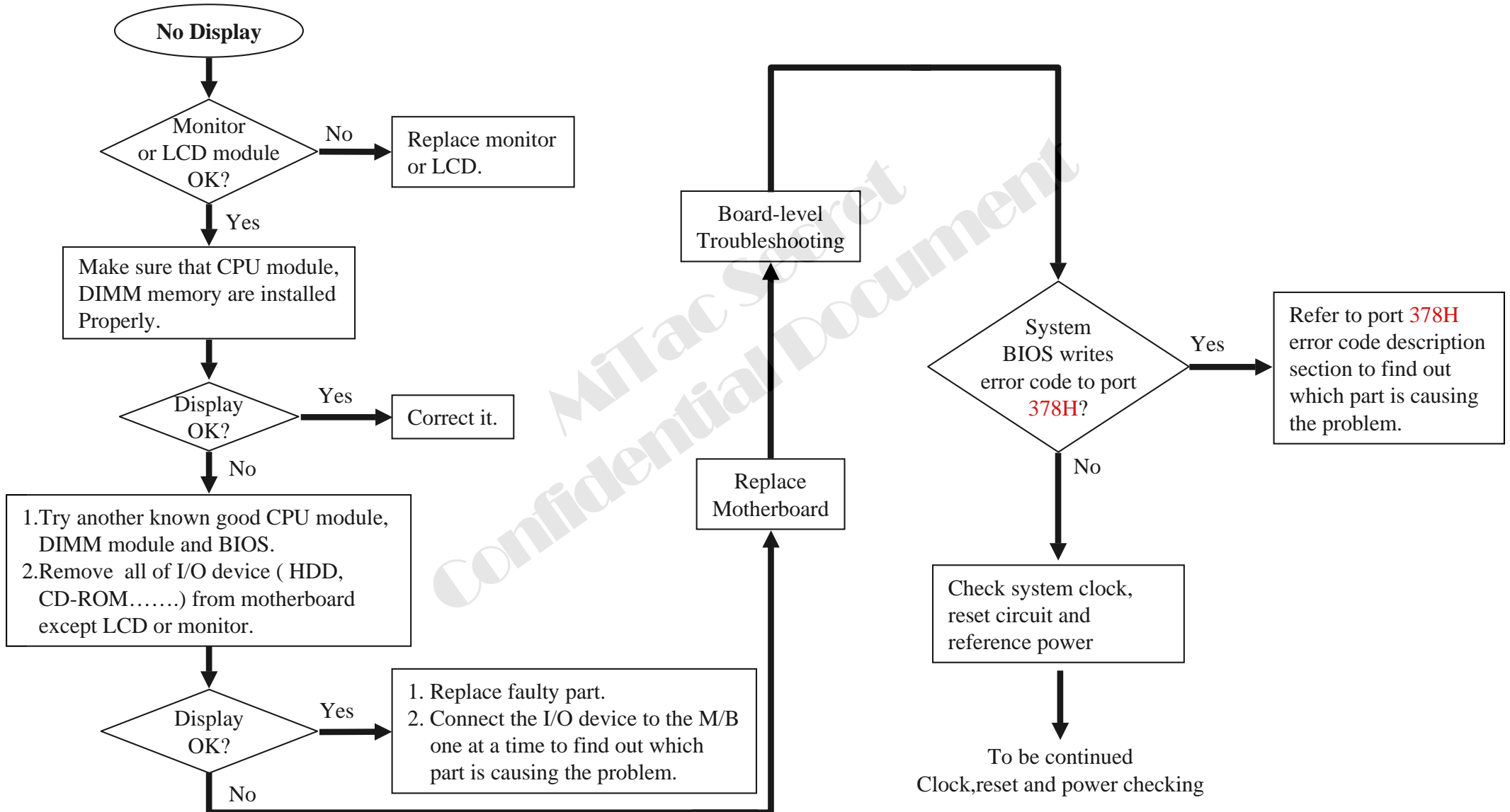

8224 N/B Maintenance

8.2 No Display-2

***** System Clock Check *****

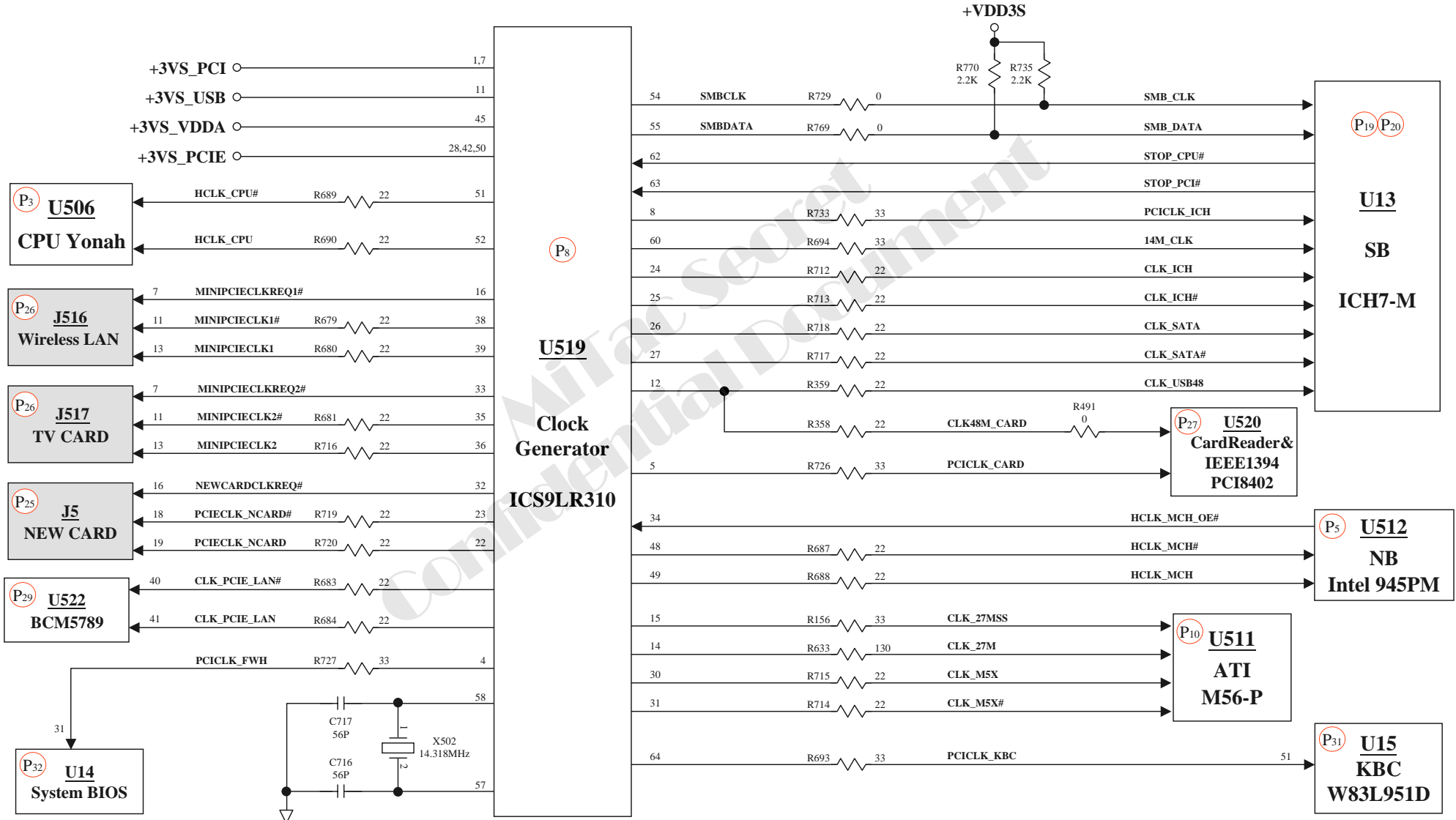

8224 N/B Maintenance

8.2 No Display-3

***** Power Good & Reset Circuit Check *****

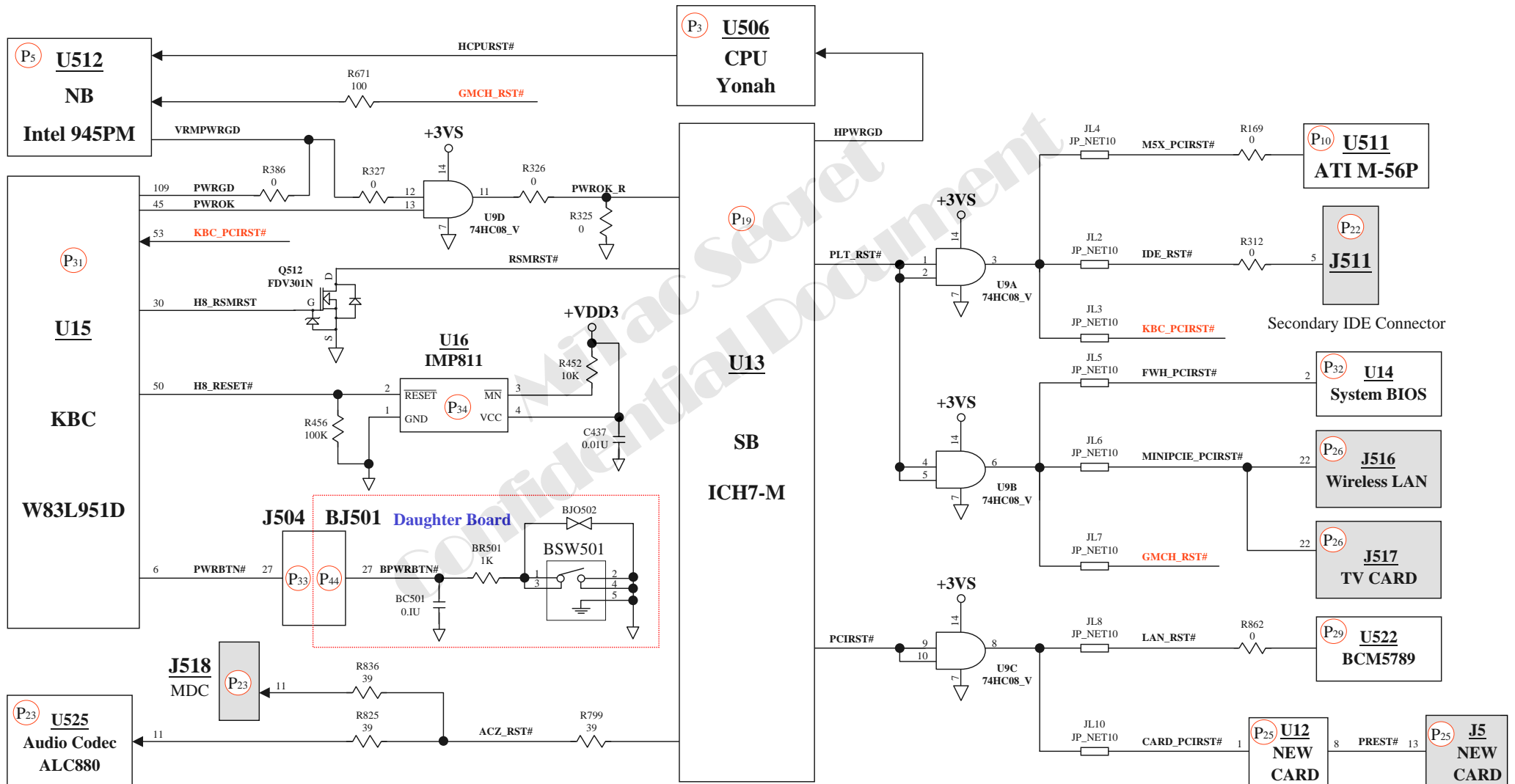

8224 N/B Maintenance

8.3 TV Out Test Error-1

There is no display or picture abnormal on TV.

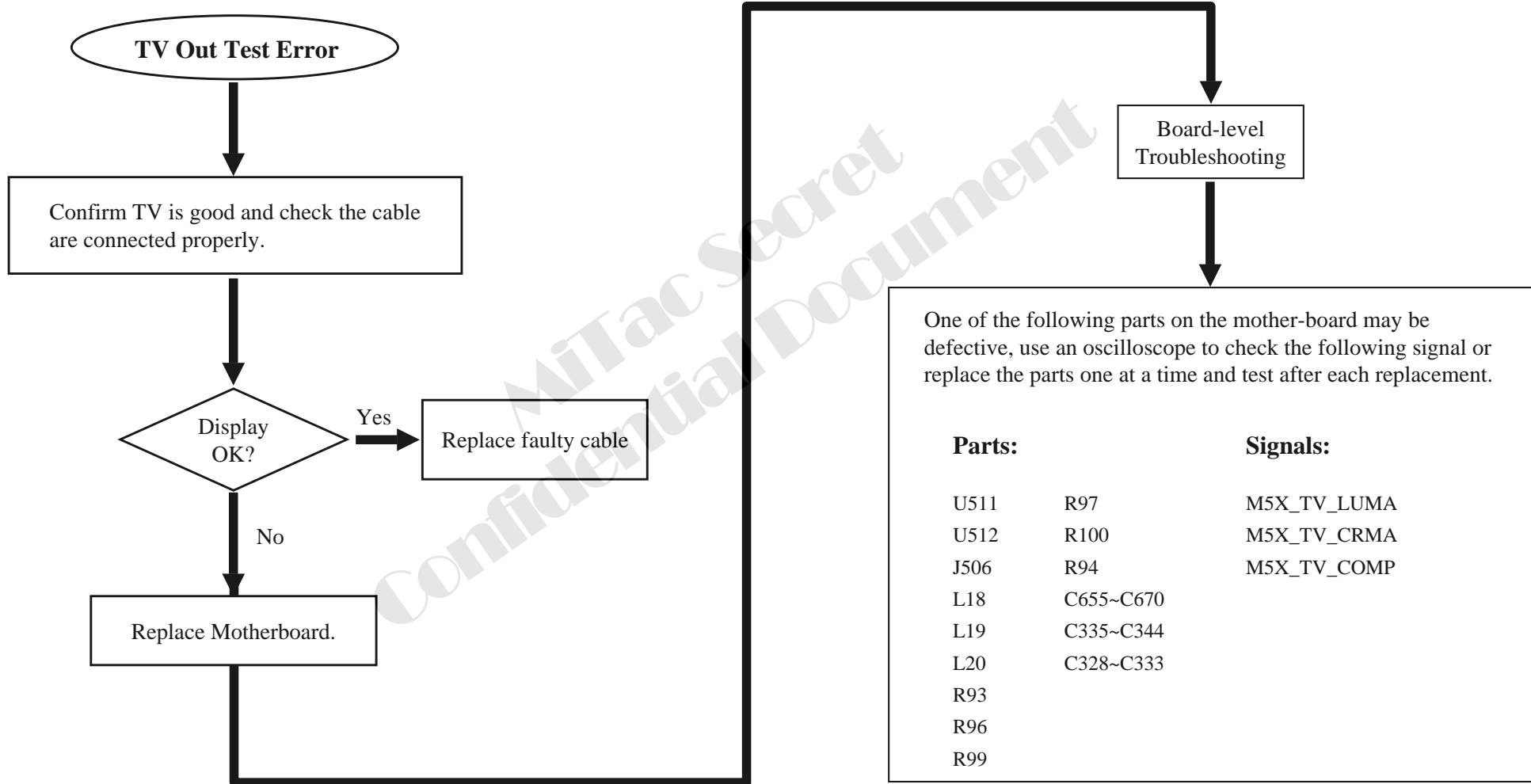

8224 N/B Maintenance

8.3 TV Out Test Error-2

There is no display or picture abnormal on TV.

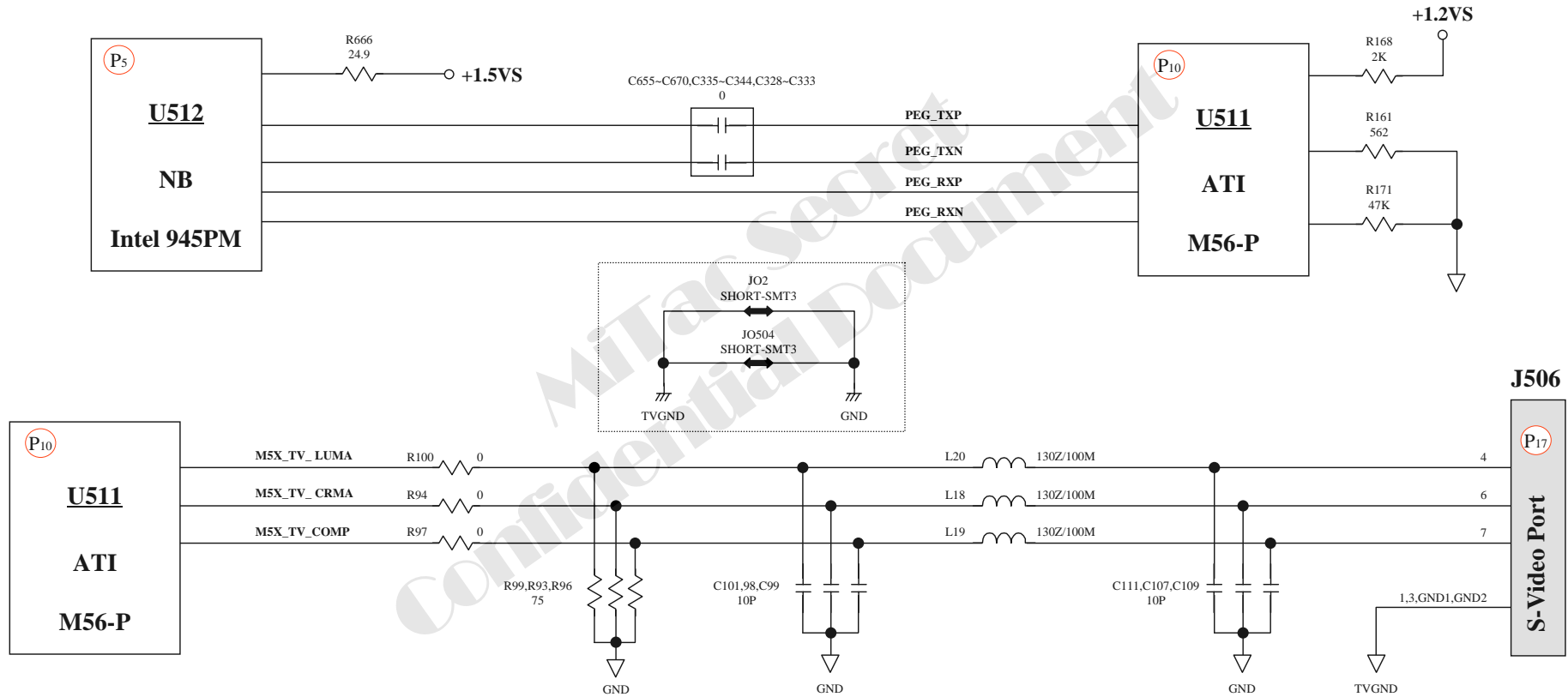

8224 N/B Maintenance

8.4 VGA Controller Test Error LCD No Display-1

There is no display or picture abnormal on LCD although power-on-self-test is passed.

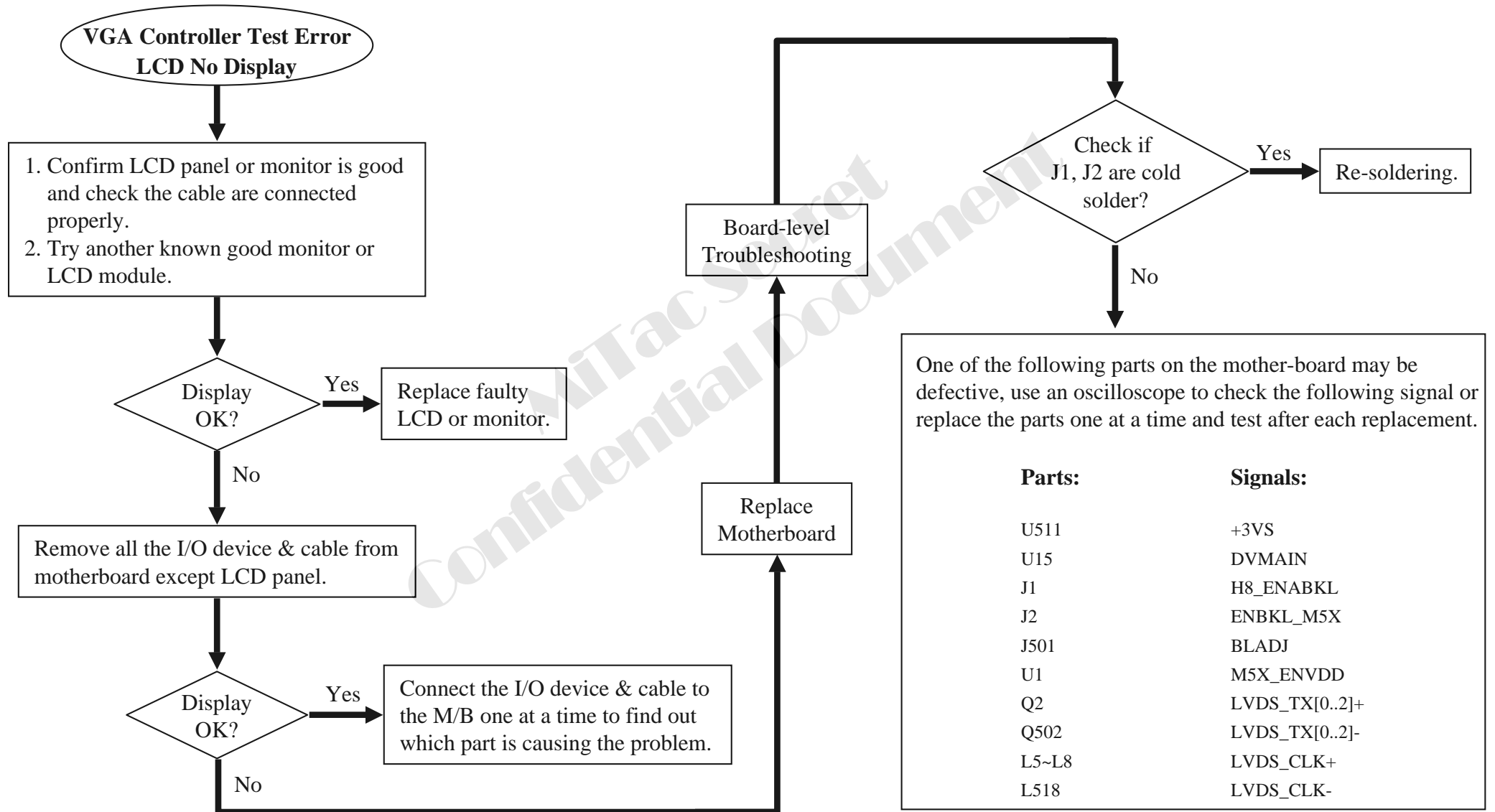

8224 N/B Maintenance

8.4 VGA Controller Test Error LCD No Display-2

There is no display or picture abnormal on LCD although power-on-self-test is passed.

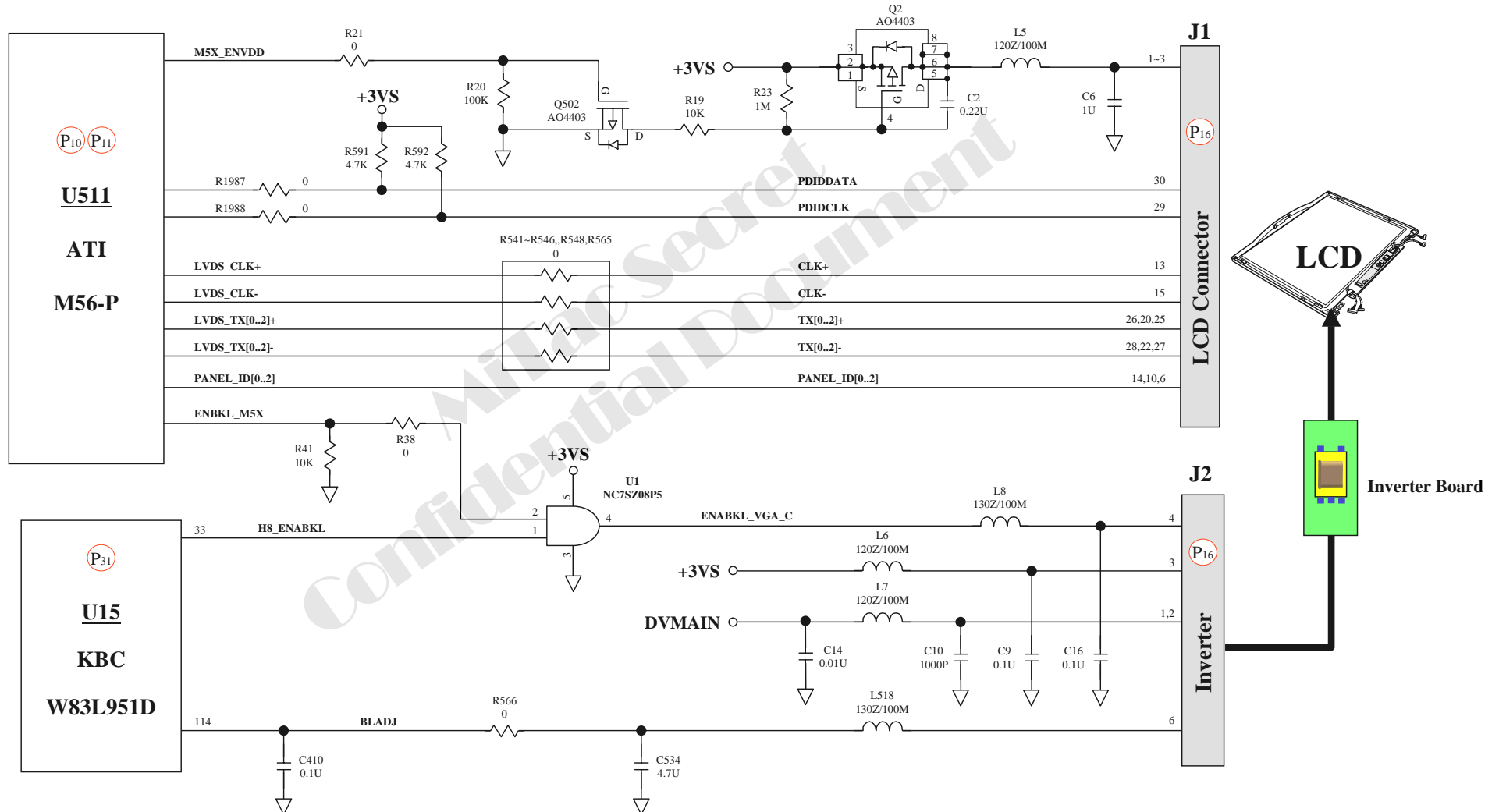

8224 N/B Maintenance

8.5 External Monitor No Display-1

There is no display or picture abnormal on CRT/DVI monitor, but it is OK for LCD.

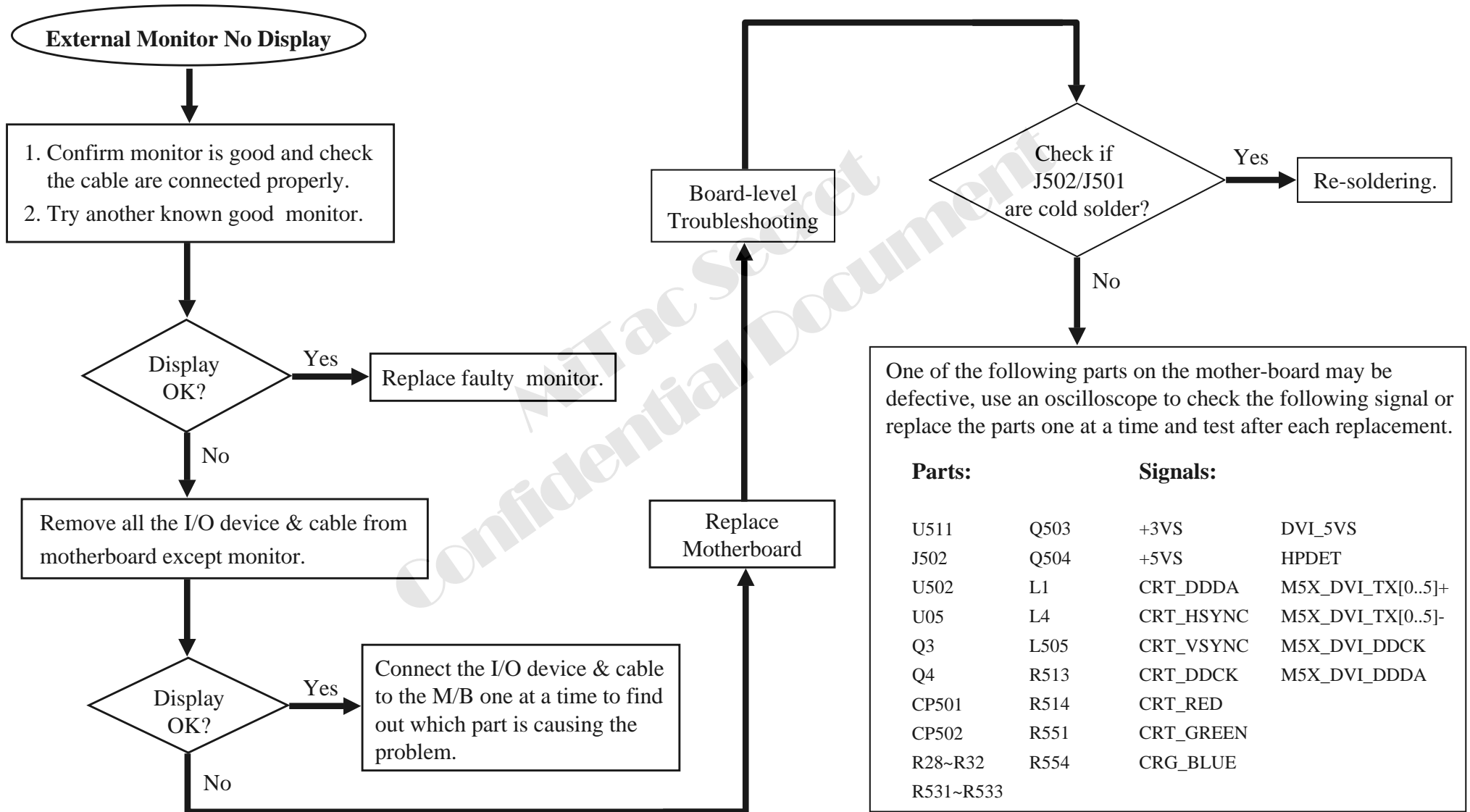

8224 N/B Maintenance

8.5 External Monitor No Display-2 (CRT Monitor)

There is no display or picture abnormal on CRT monitor, but it is OK for LCD.

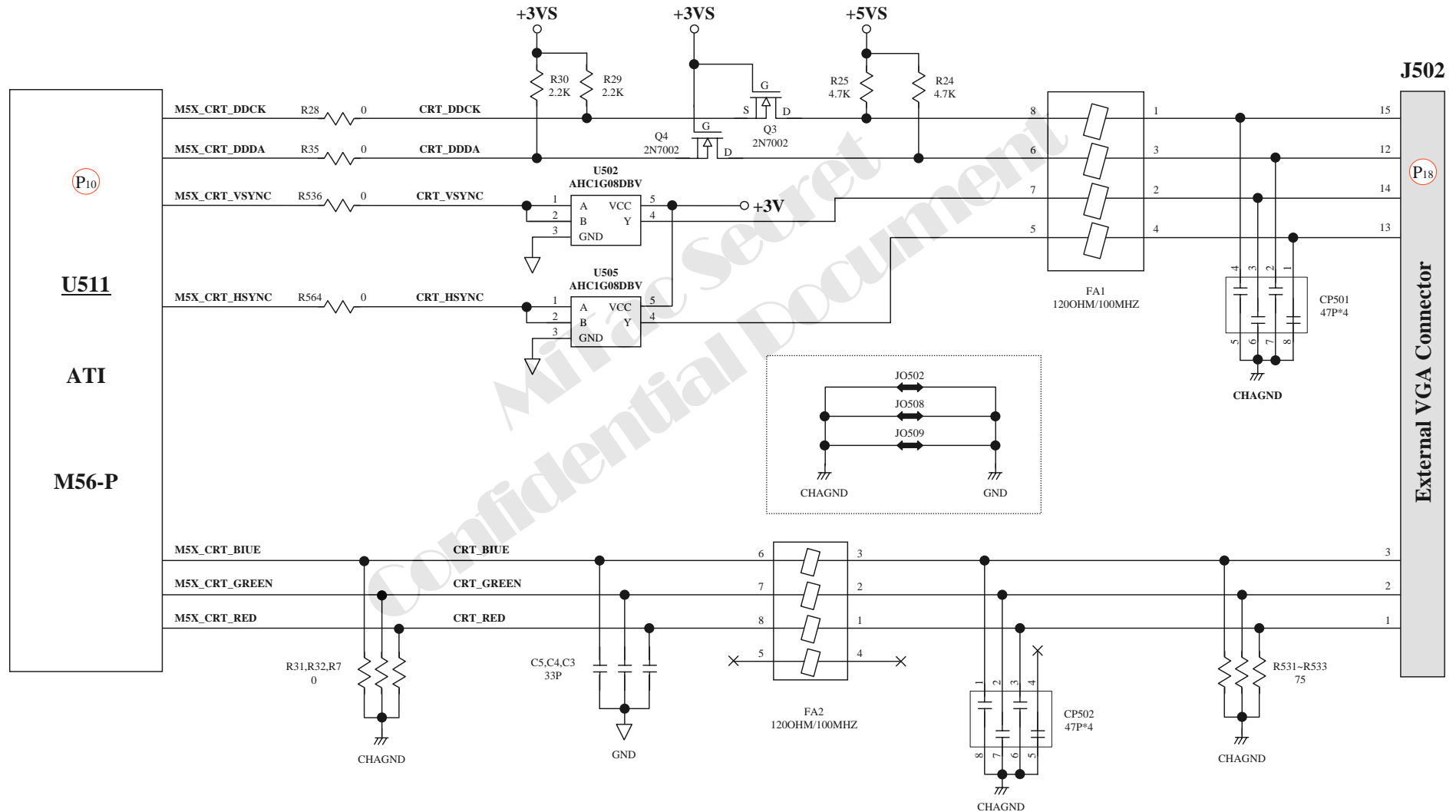

8224 N/B Maintenance

8.5 External Monitor No Display-3 (DVI Monitor)

There is no display or picture abnormal on DVI monitor, but it is OK for LCD.

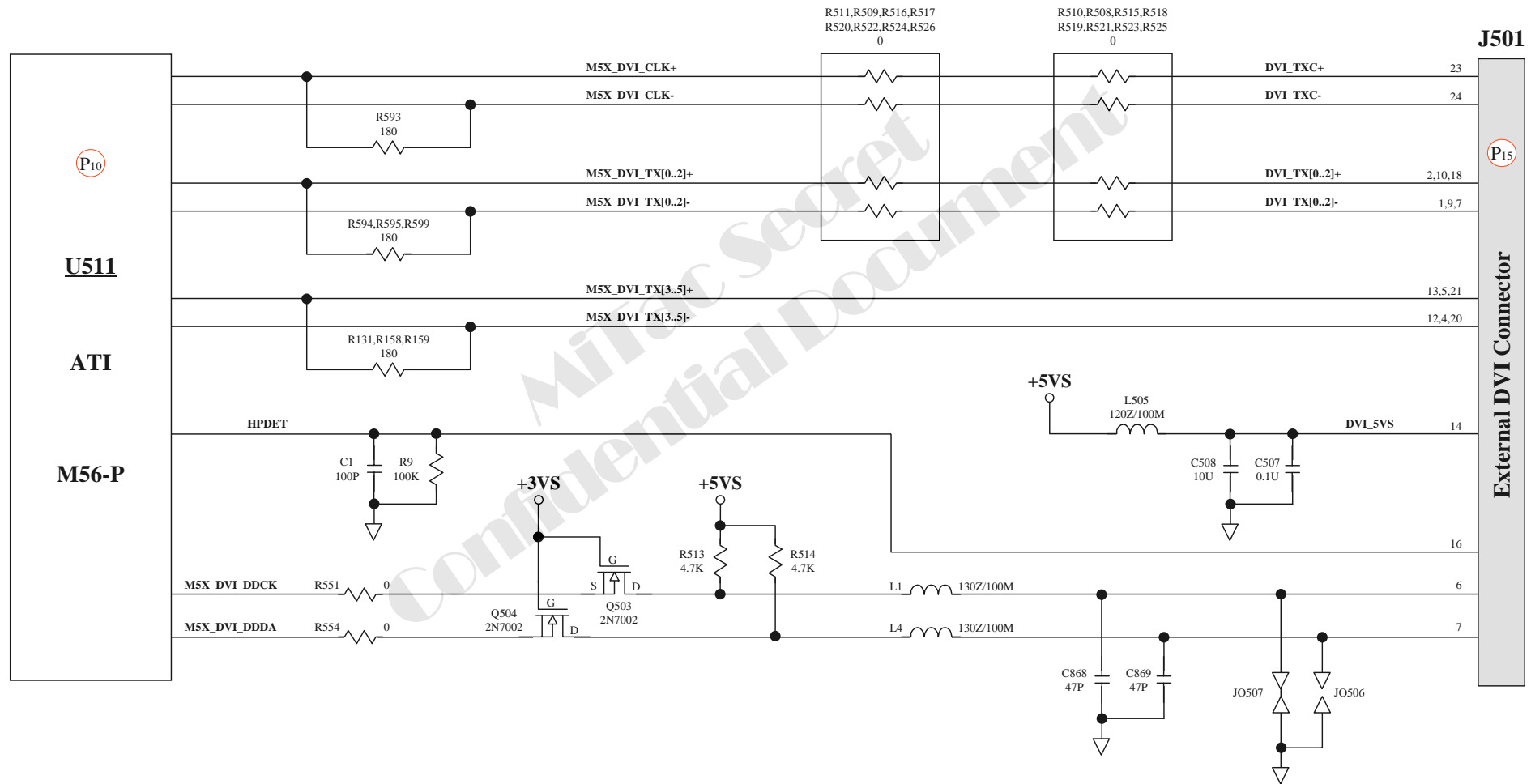

8224 N/B Maintenance

8.6 Memory Test Error-1

Extend DDR2-DIMM is failure or system hangs up.

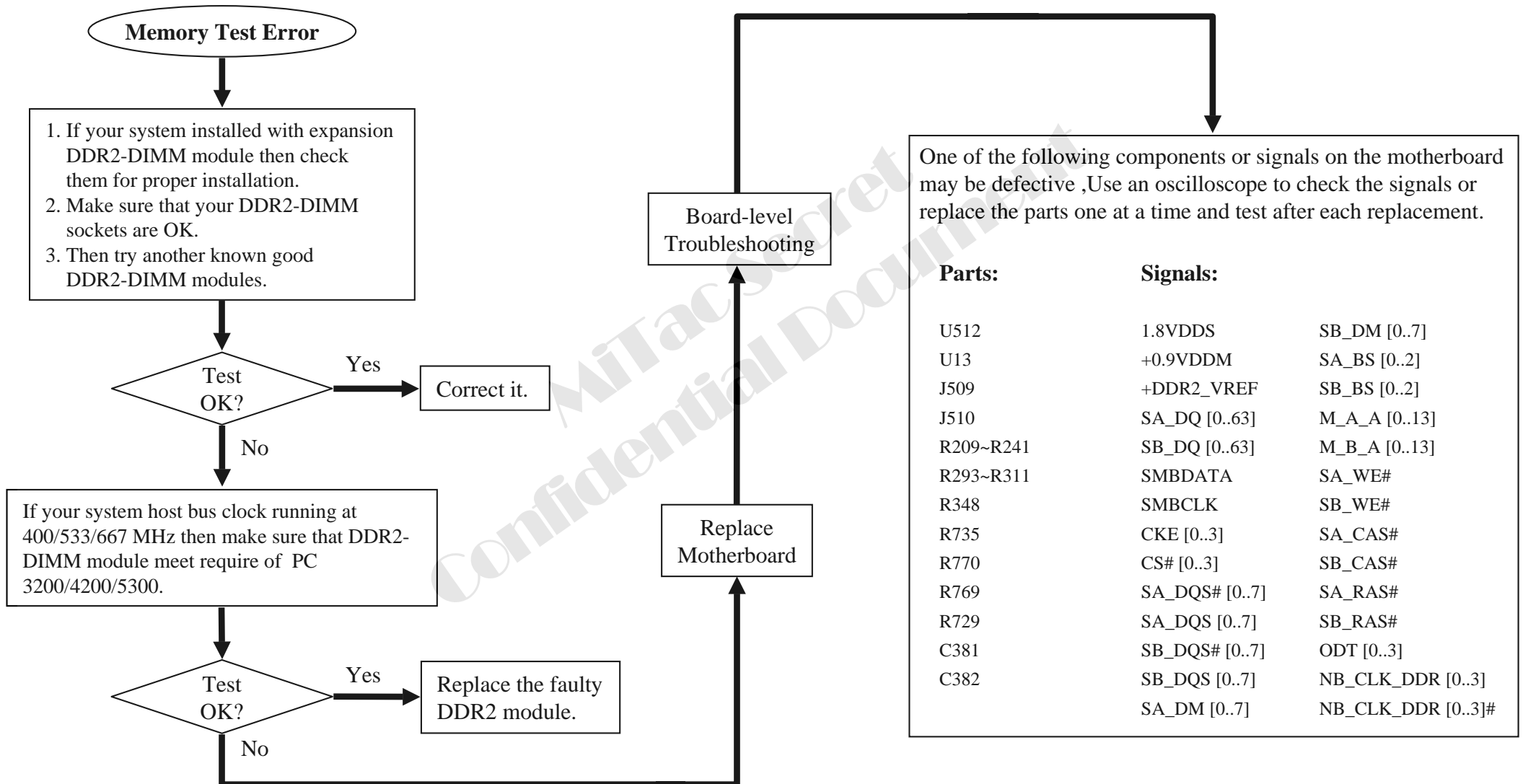

8224 N/B Maintenance

8.6 Memory Test Error-2

Extend DDR2-DIMM is failure or system hangs up.

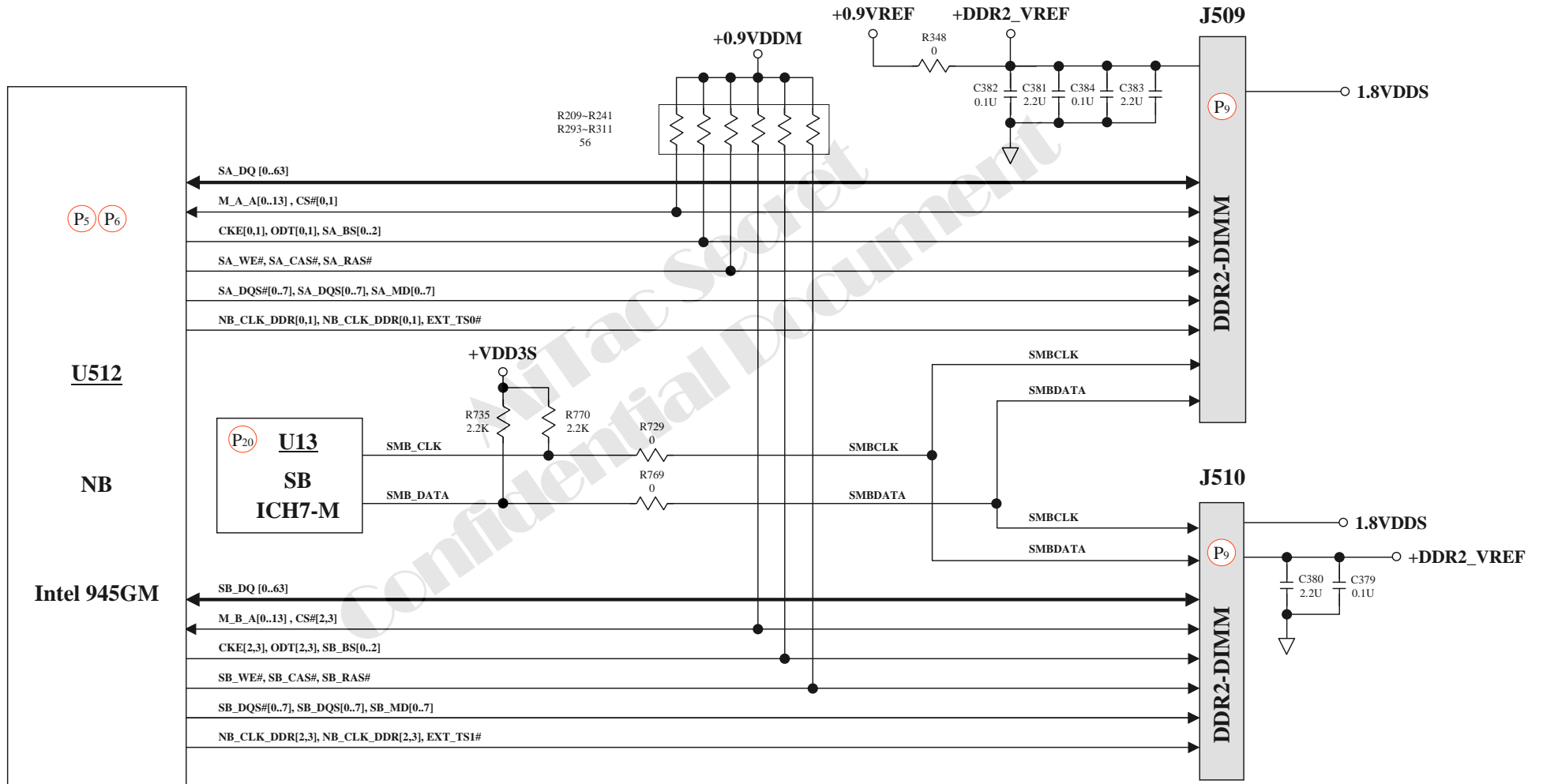

8224 N/B Maintenance

8.7 Keyboard (K/B) or Touch-Pad (T/P) Test Error-1

Error message of keyboard or touch-pad failure is shown or any key does not work.

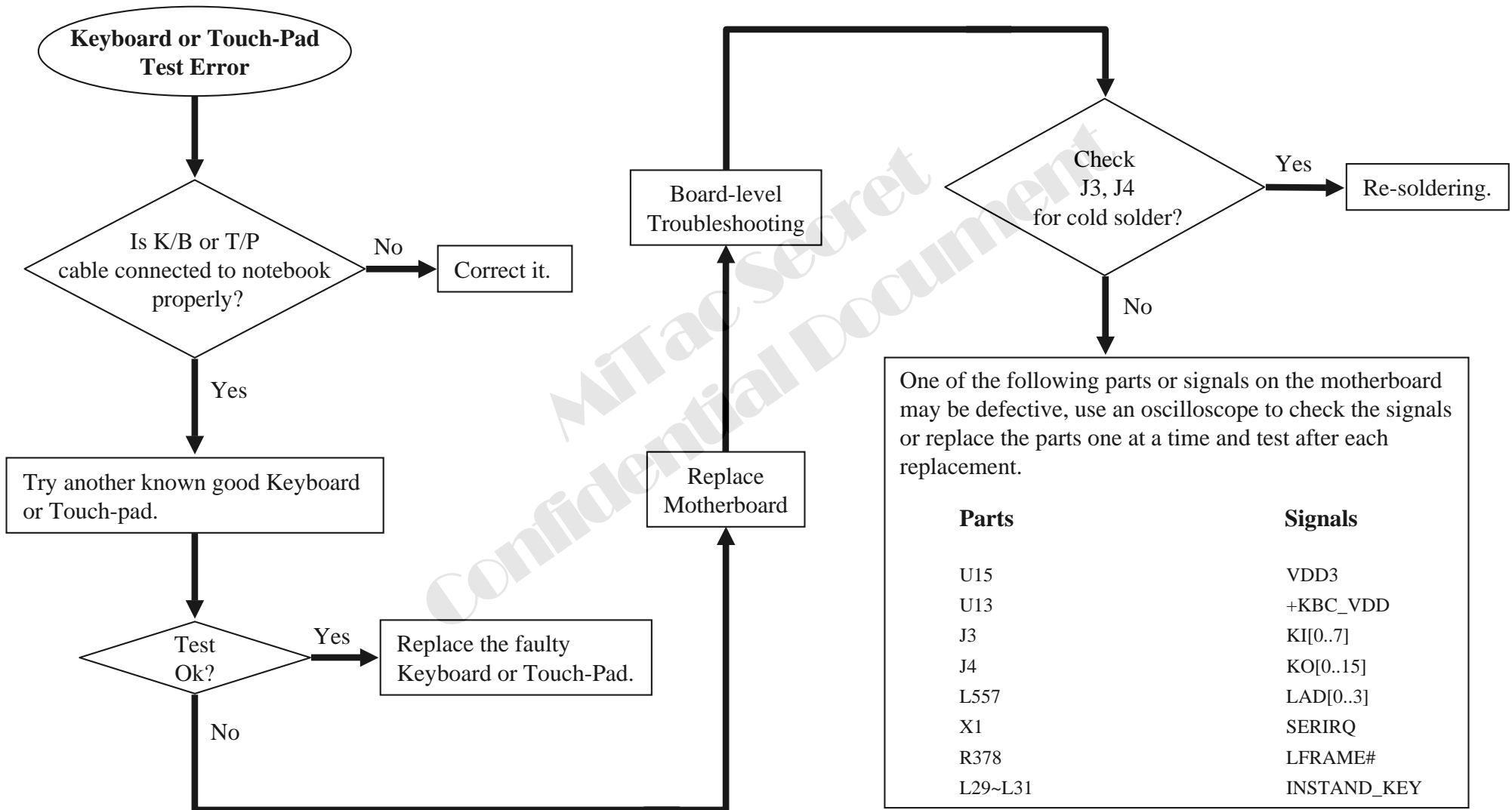

8224 N/B Maintenance

8.7 Keyboard (K/B) or Touch-Pad (T/P) Test Error-2

Error message of keyboard or touch-pad failure is shown or any key does not work.

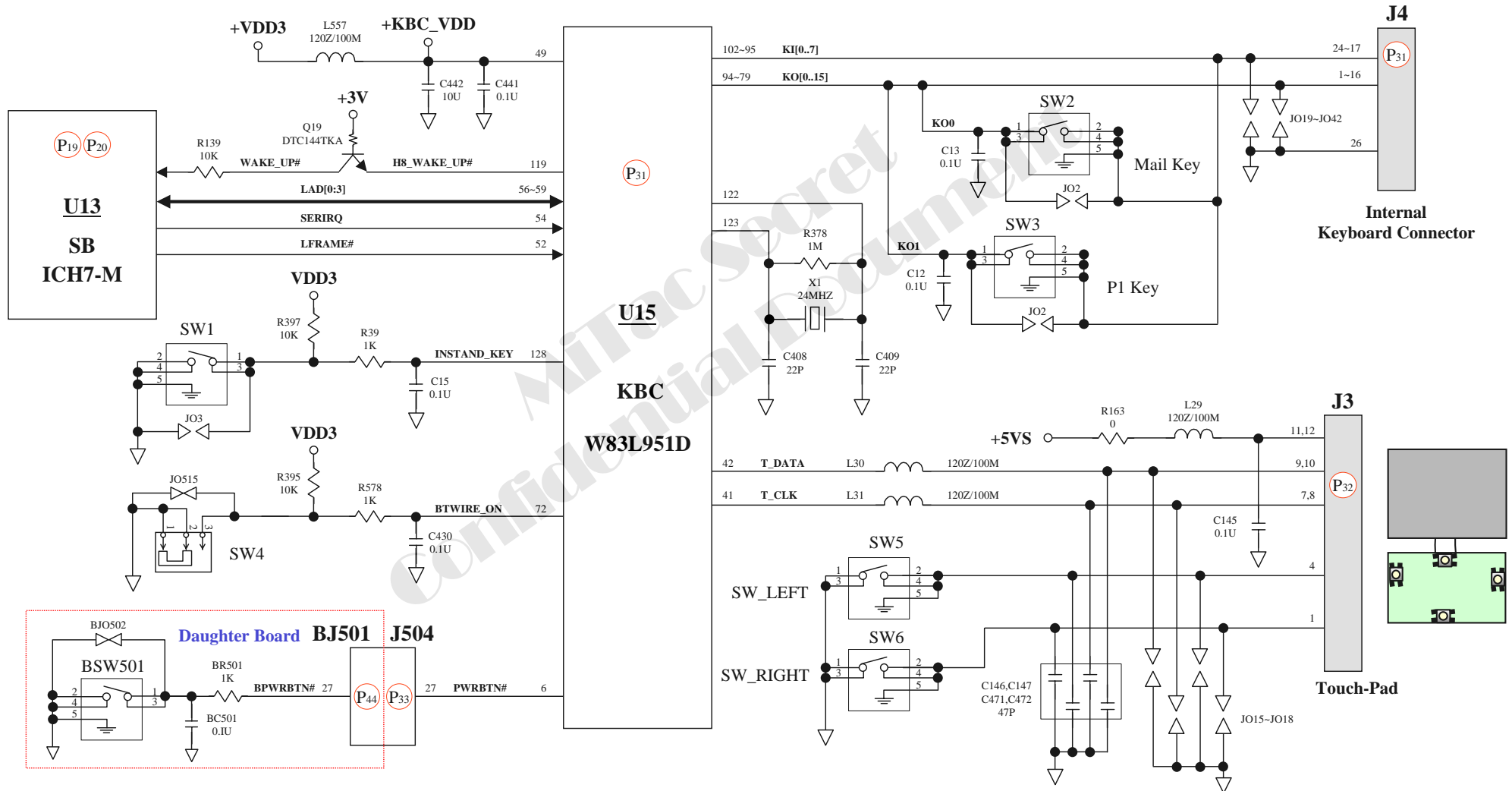

8224 N/B Maintenance

8.8 Hard Drive Test Error-1

Either an error message is shown, or the drive motor spins non-stop, while reading data from or writing data to hard disk.

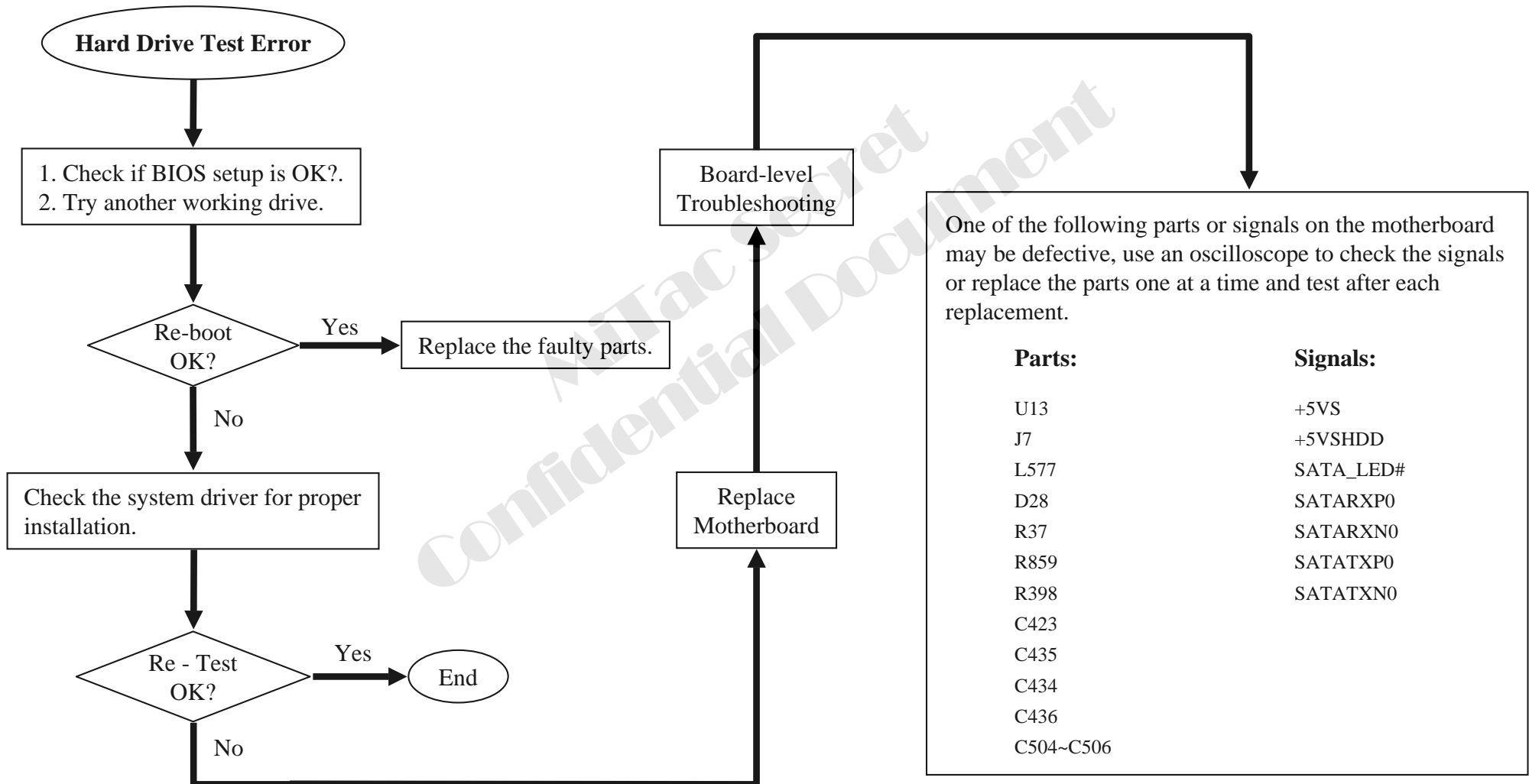

8224 N/B Maintenance

8.8 Hard Drive Test Error-2

Either an error message is shown, or the drive motor spins non-stop, while reading data from or writing data to hard disk.

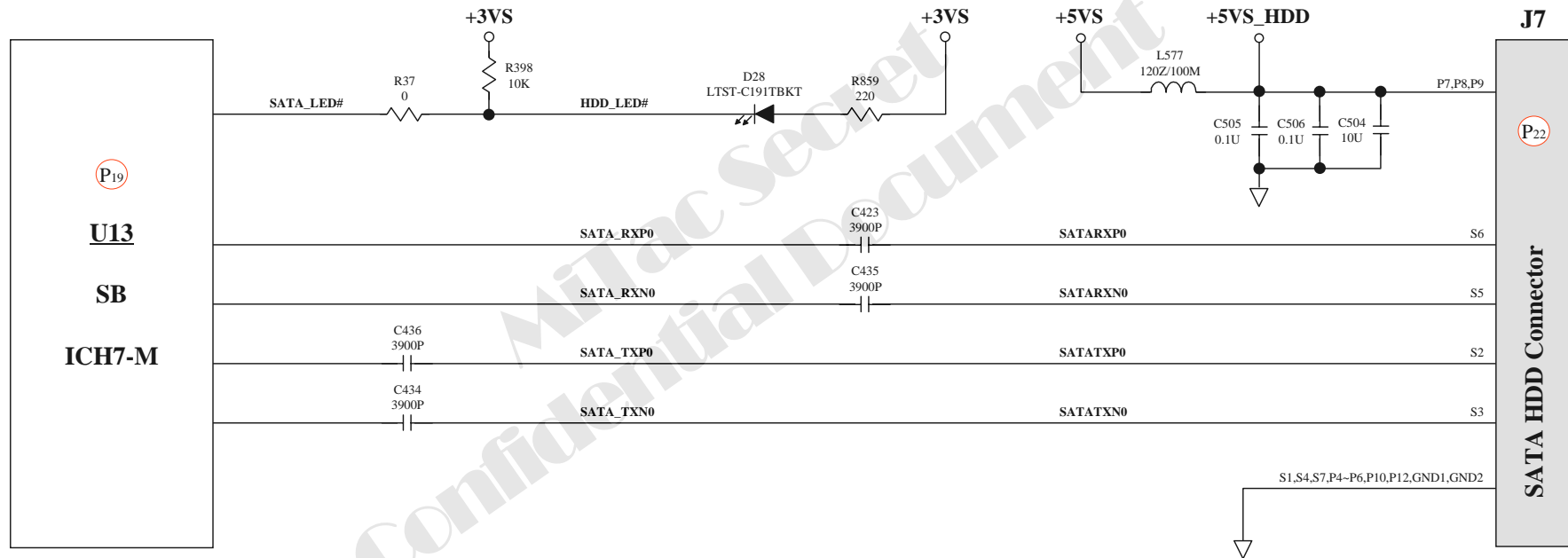

8224 N/B Maintenance

8.9 CD-ROM Drive Test Error-1

An error message is shown when reading data from CD-ROM drive.

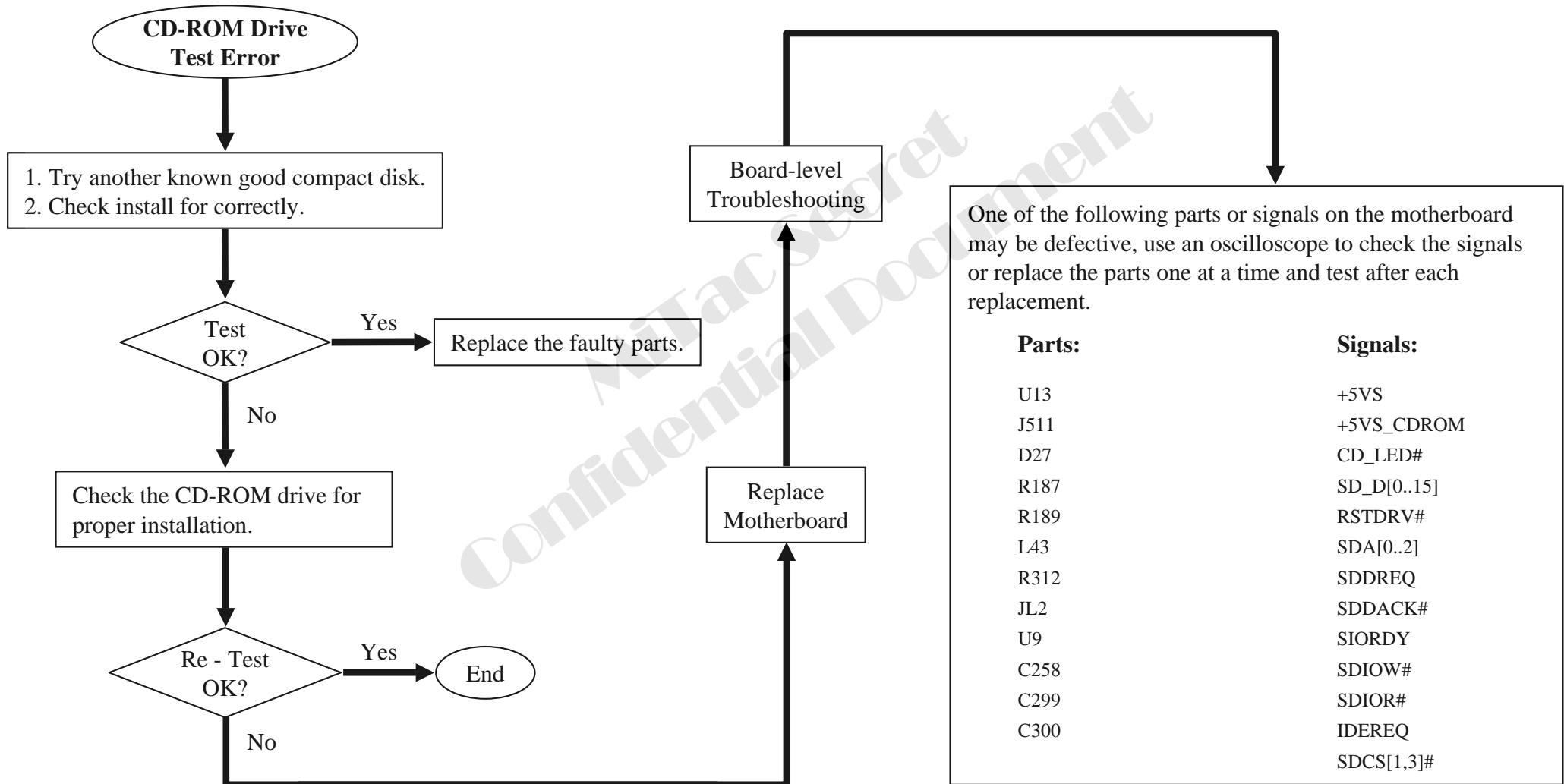

8224 N/B Maintenance

8.9 CD-ROM Drive Test Error-2

An error message is shown when reading data from CD-ROM drive.

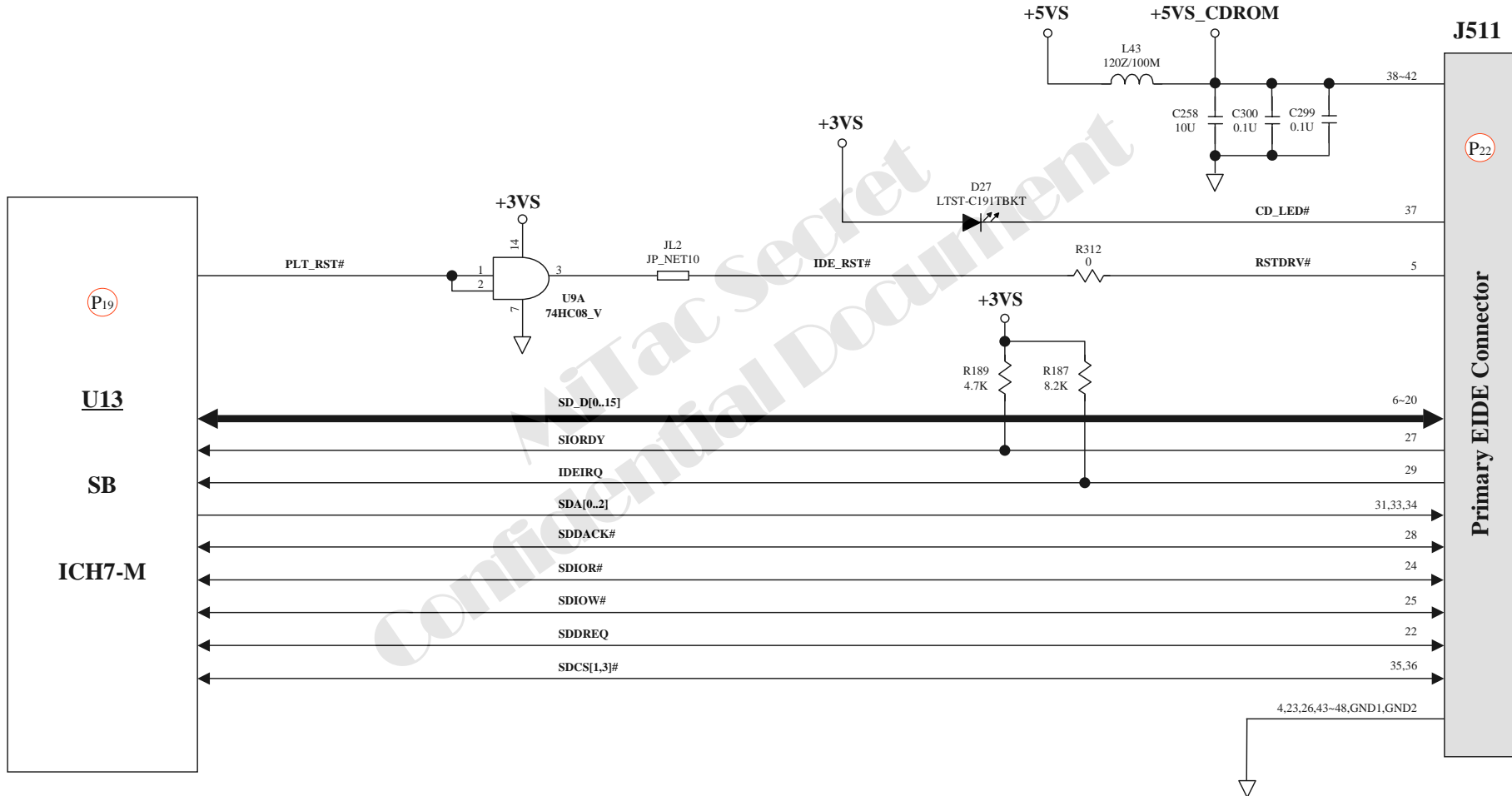

8224 N/B Maintenance

8.10 USB Port Test Error-1

An error occurs when a USB I/O device is installed.

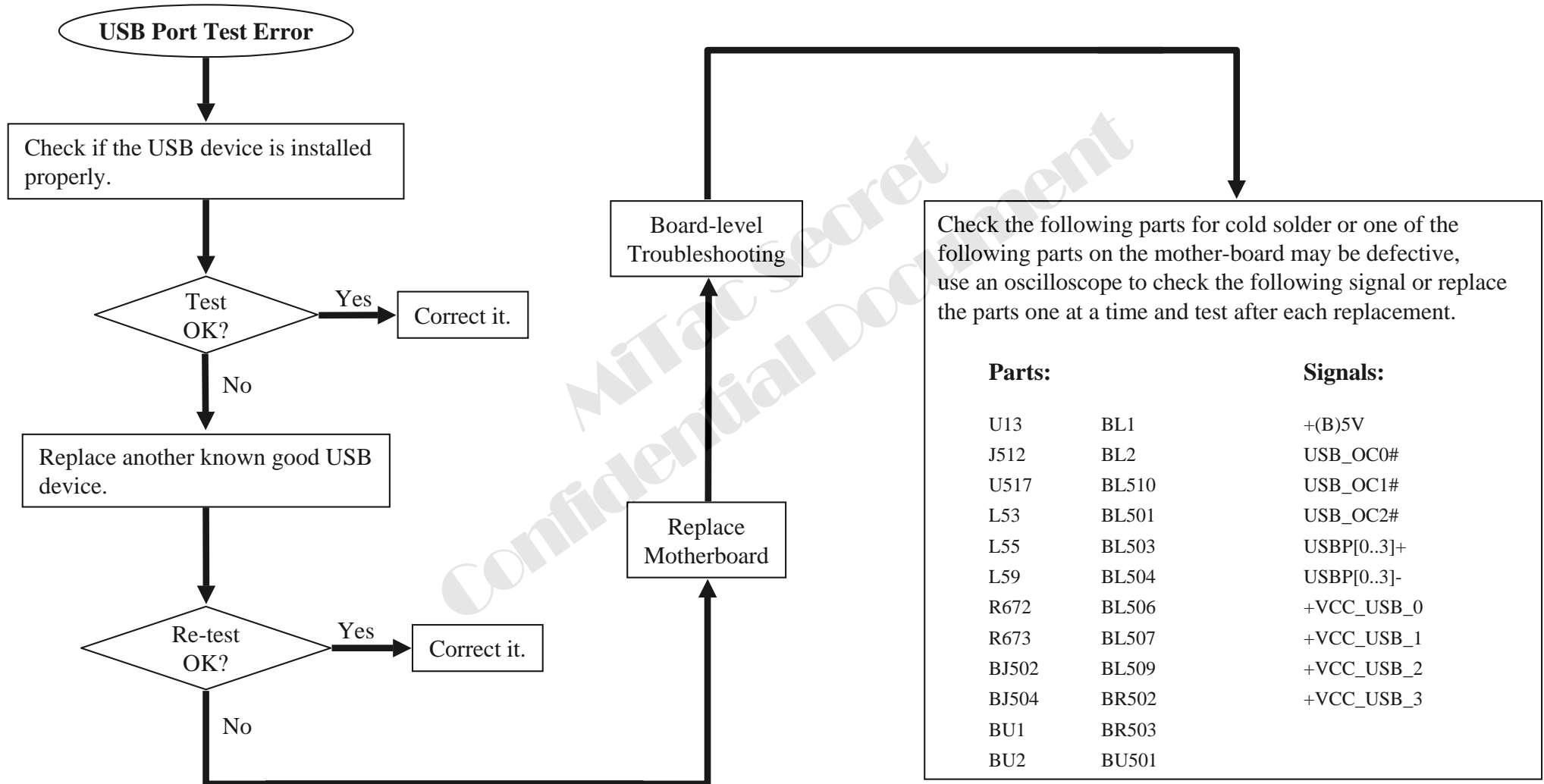

8224 N/B Maintenance

8.10 USB Port Test Error-2

An error occurs when a USB I/O device is installed.

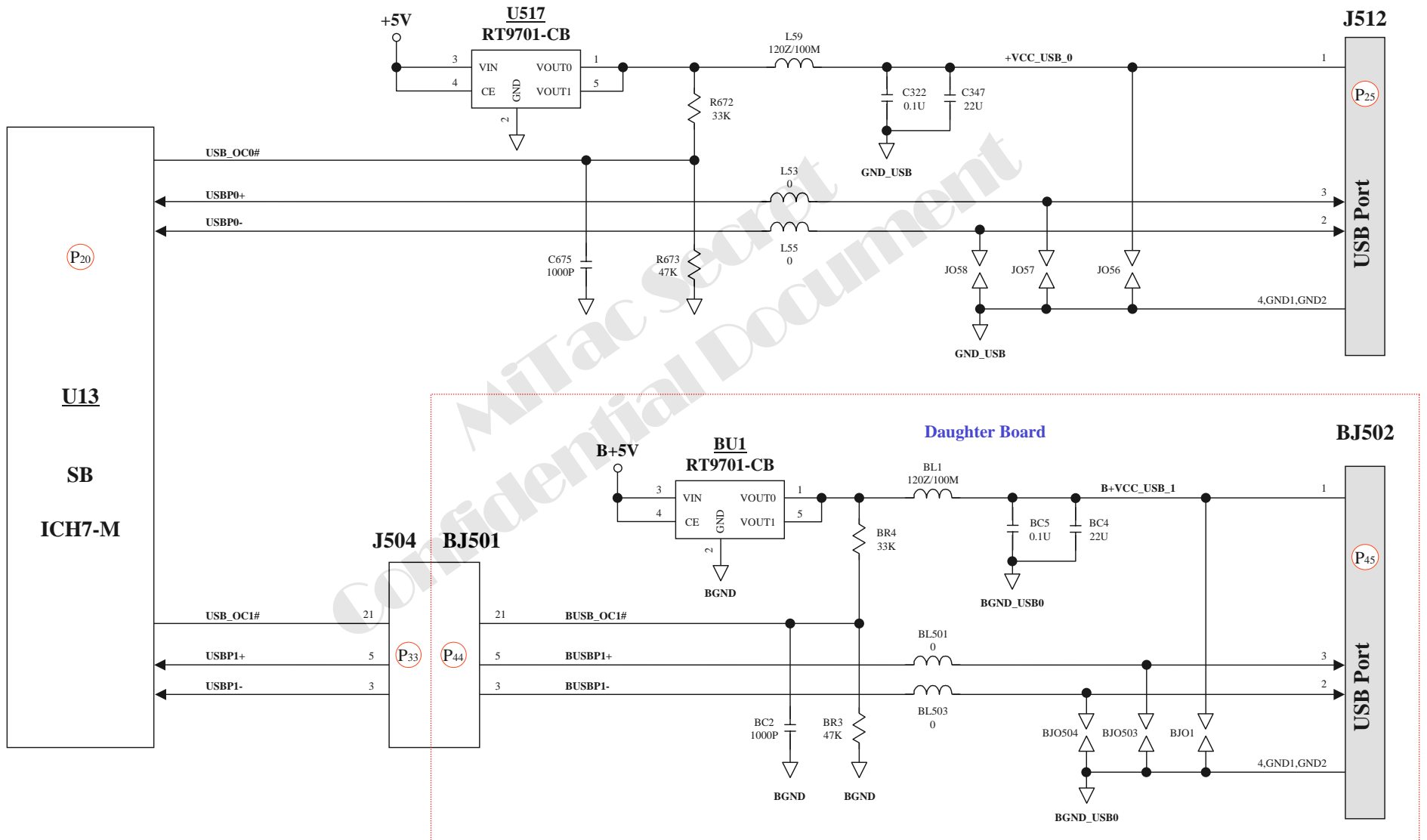

8224 N/B Maintenance

8.10 USB Port Test Error-3

An error occurs when a USB I/O device is installed.

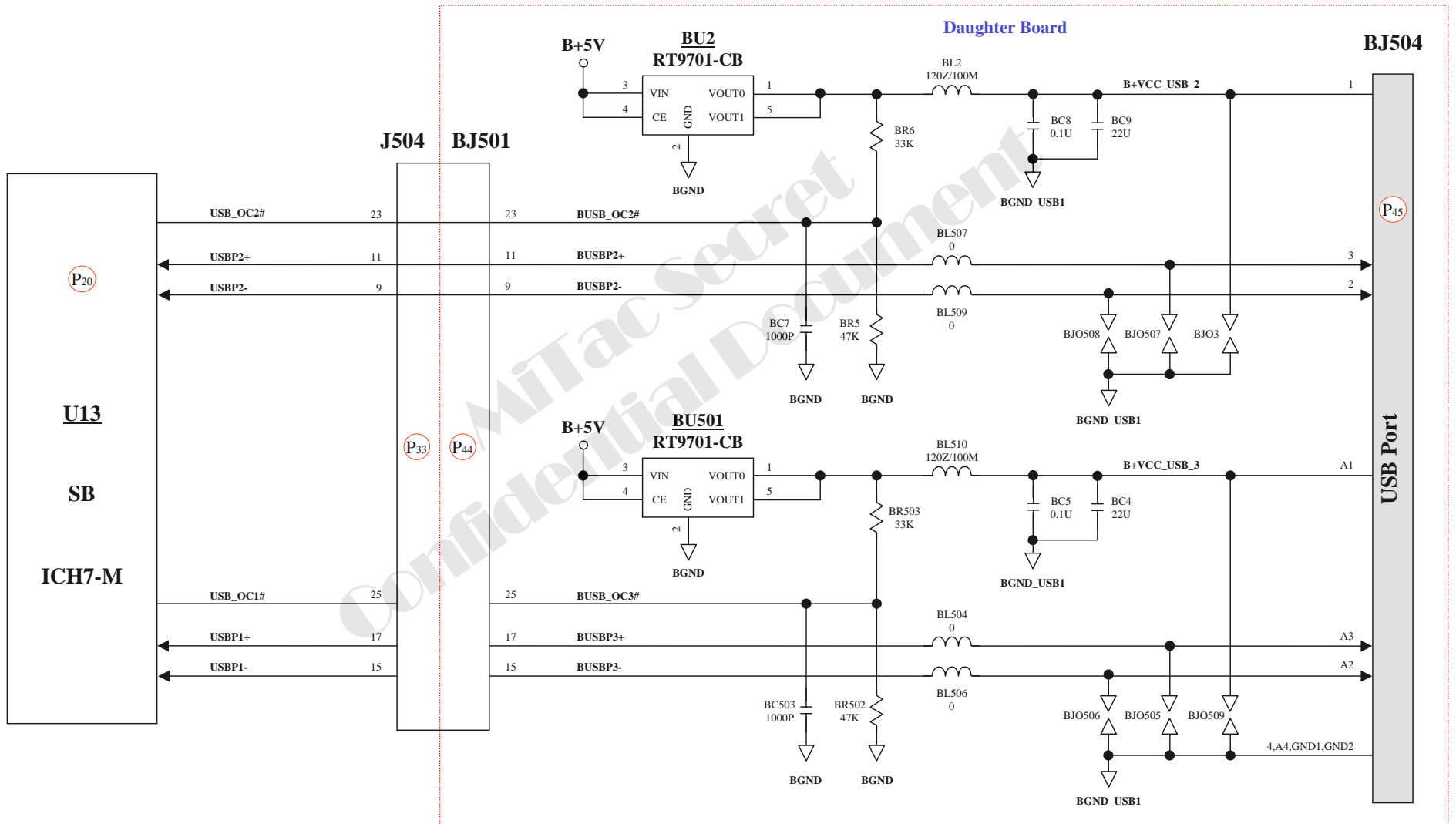

8224 N/B Maintenance

8.11 New Card Socket Test Error-1

An error occurs when a New Card device is installed.

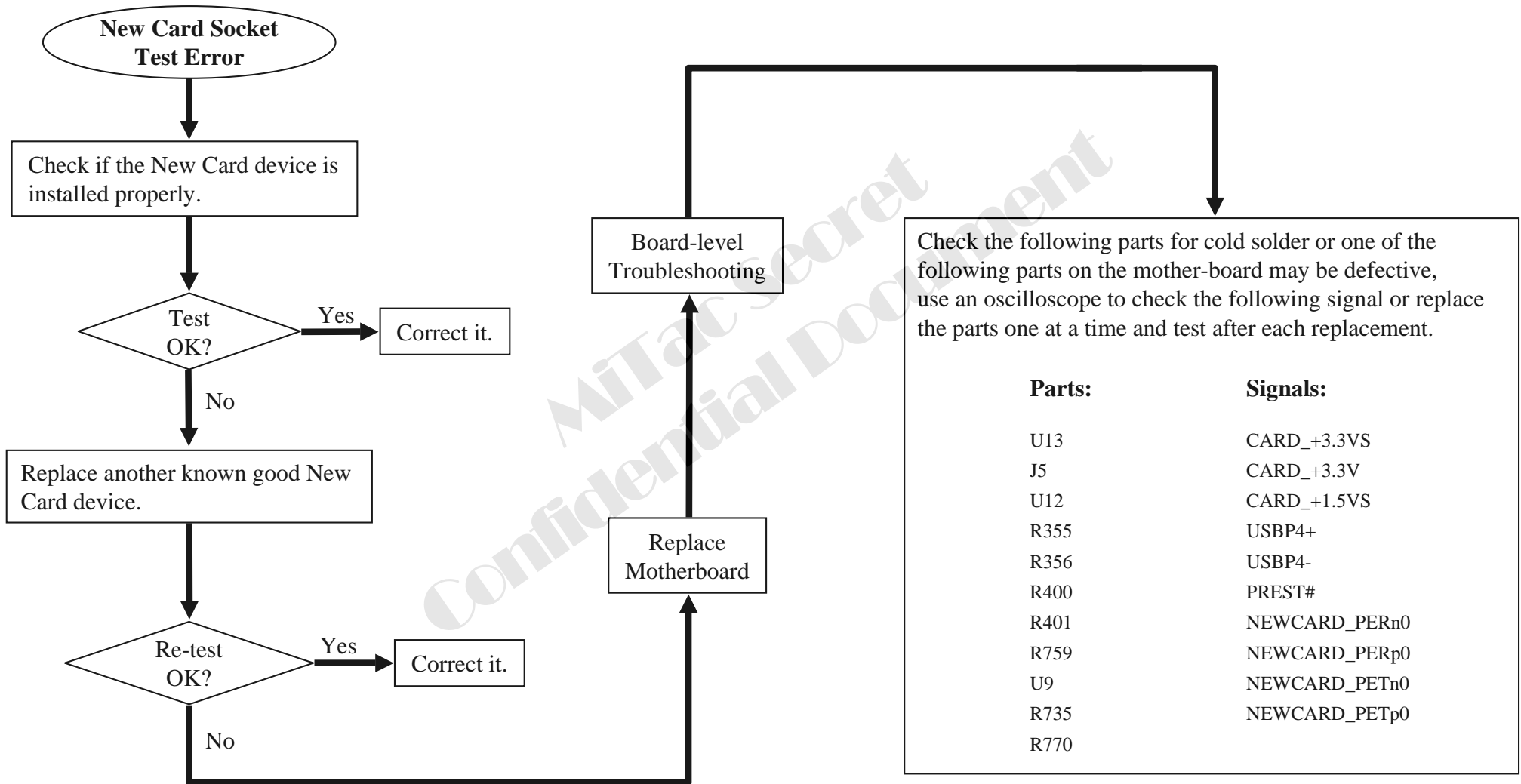

8224 N/B Maintenance

8.11 New Card Socket Test Error-2

An error occurs when a New Card device is installed.

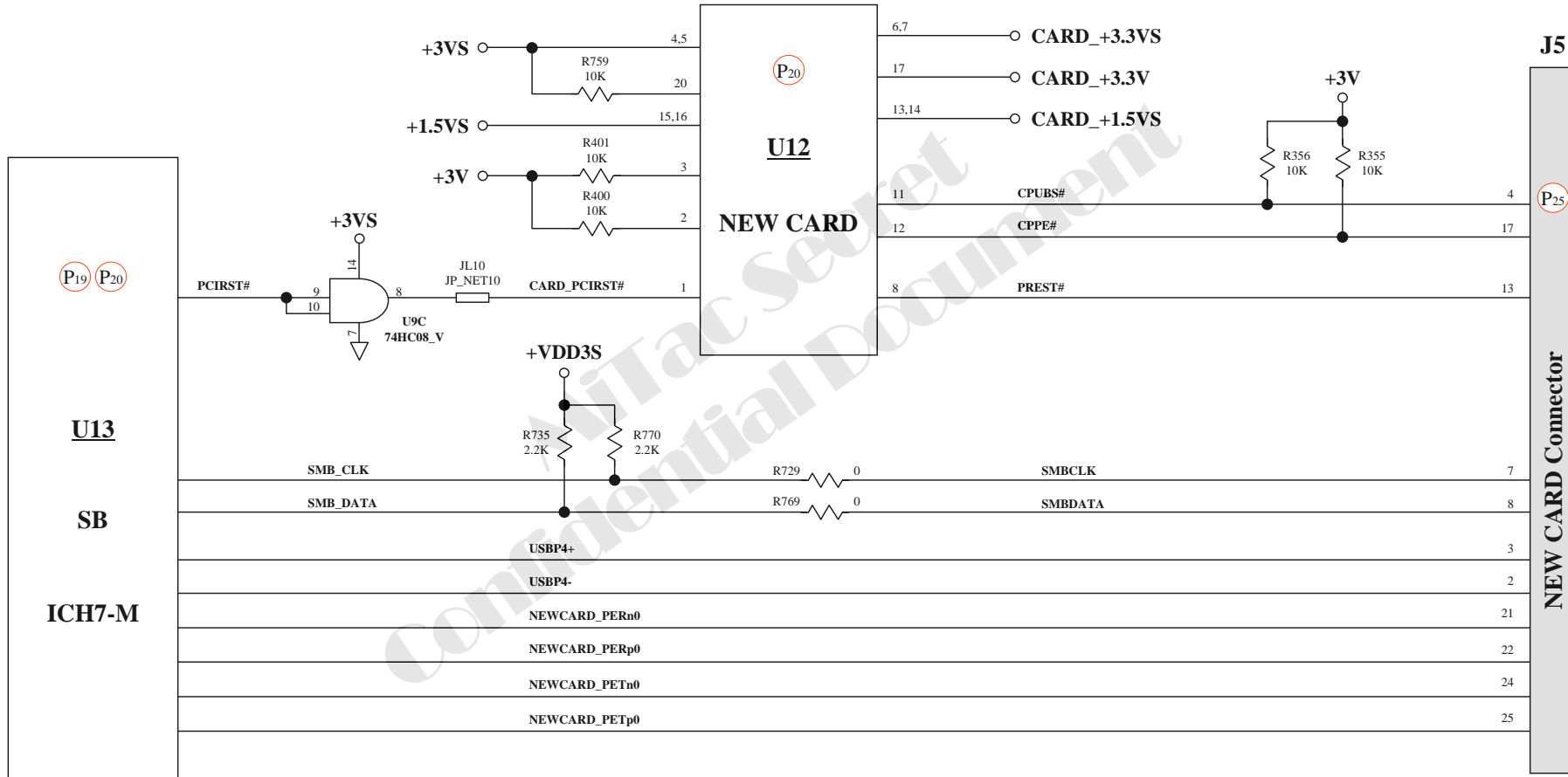

8224 N/B Maintenance

8.12 Blue Tooth Test Error-1

An error occurs when a Blue Tooth device is installed.

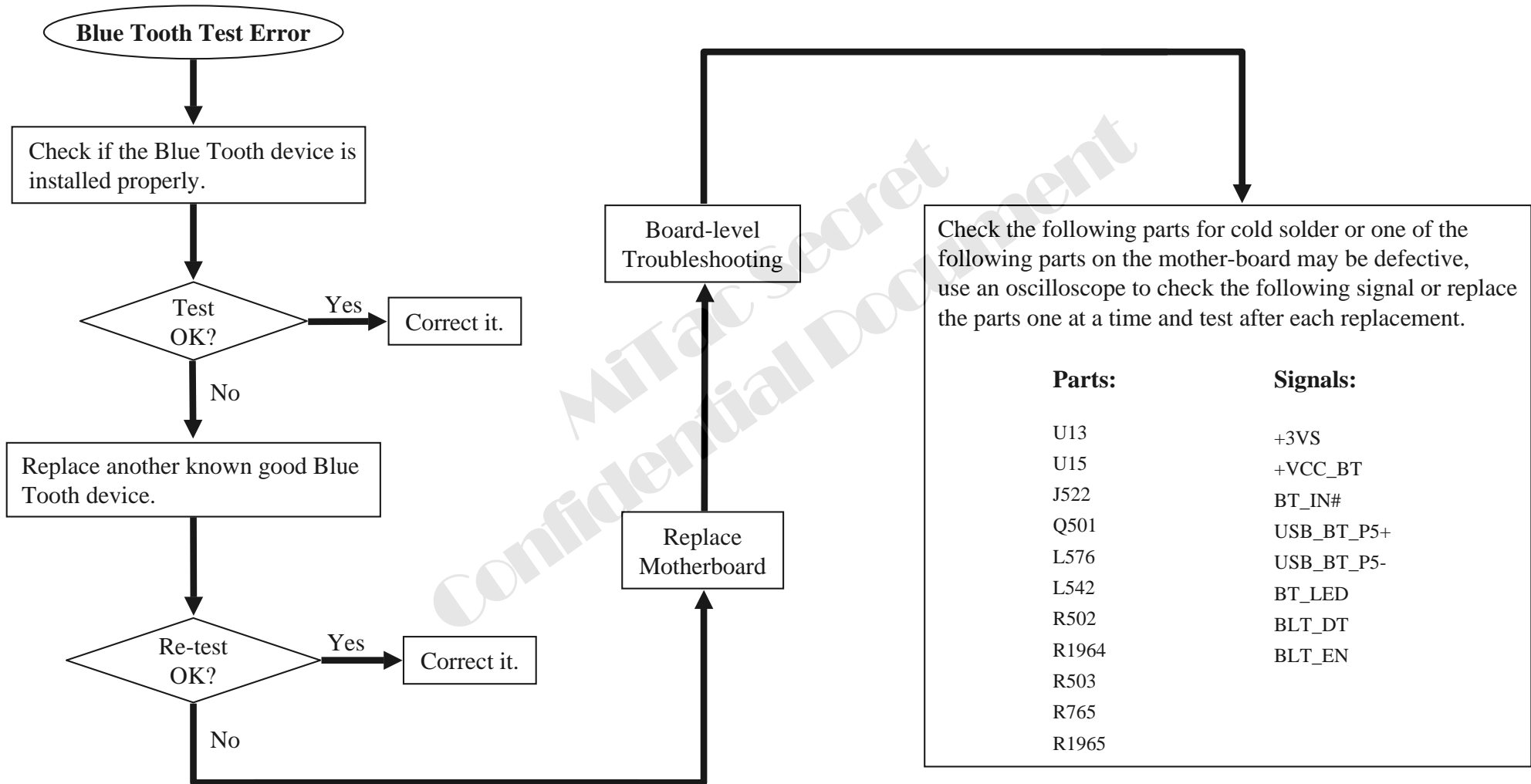

8224 N/B Maintenance

8.12 Blue Tooth Test Error-2

An error occurs when a Blue Tooth device is installed.

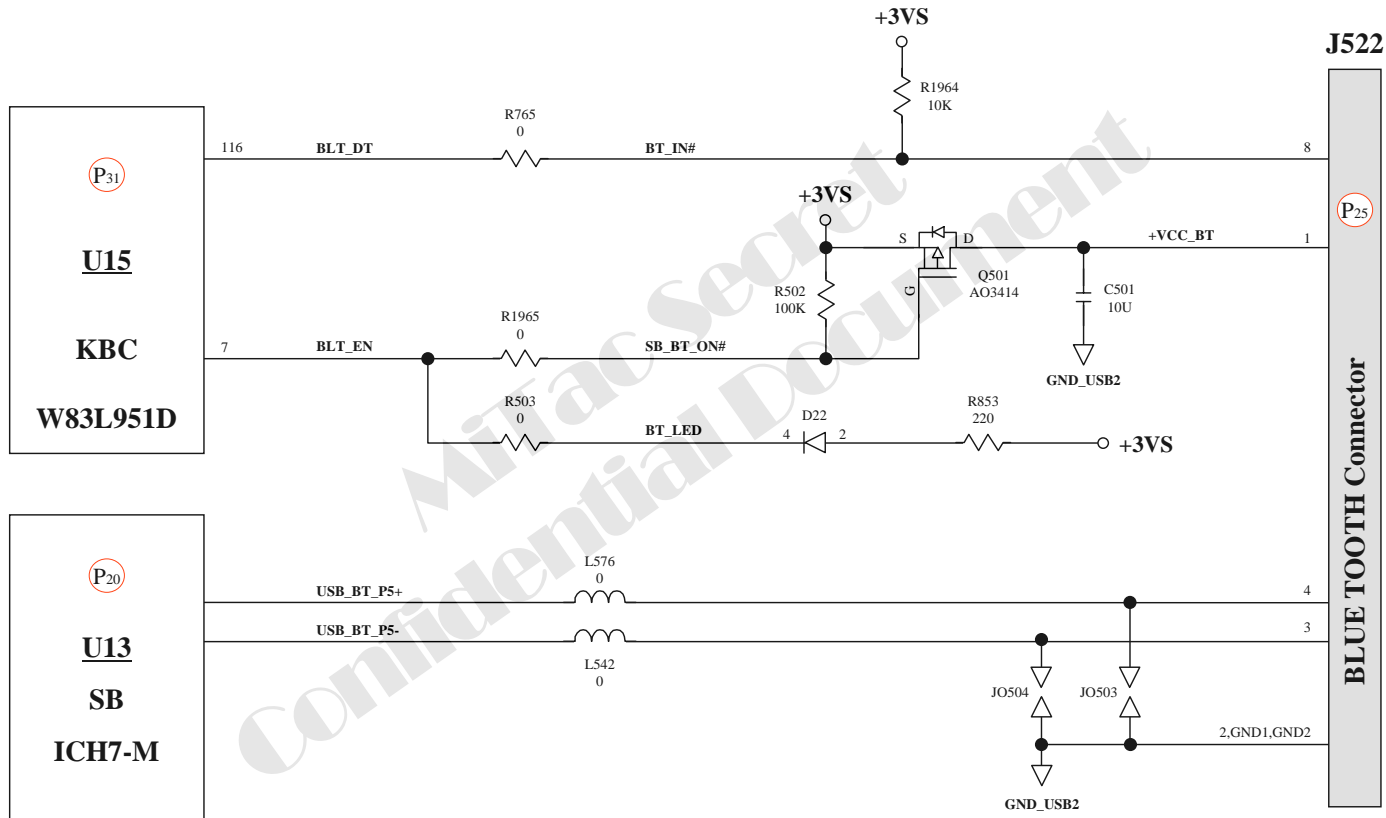

8224 N/B Maintenance

8.13 Mini-PCI Socket Test Error-1

An error occurs when a Mini-PCI Card device is installed.

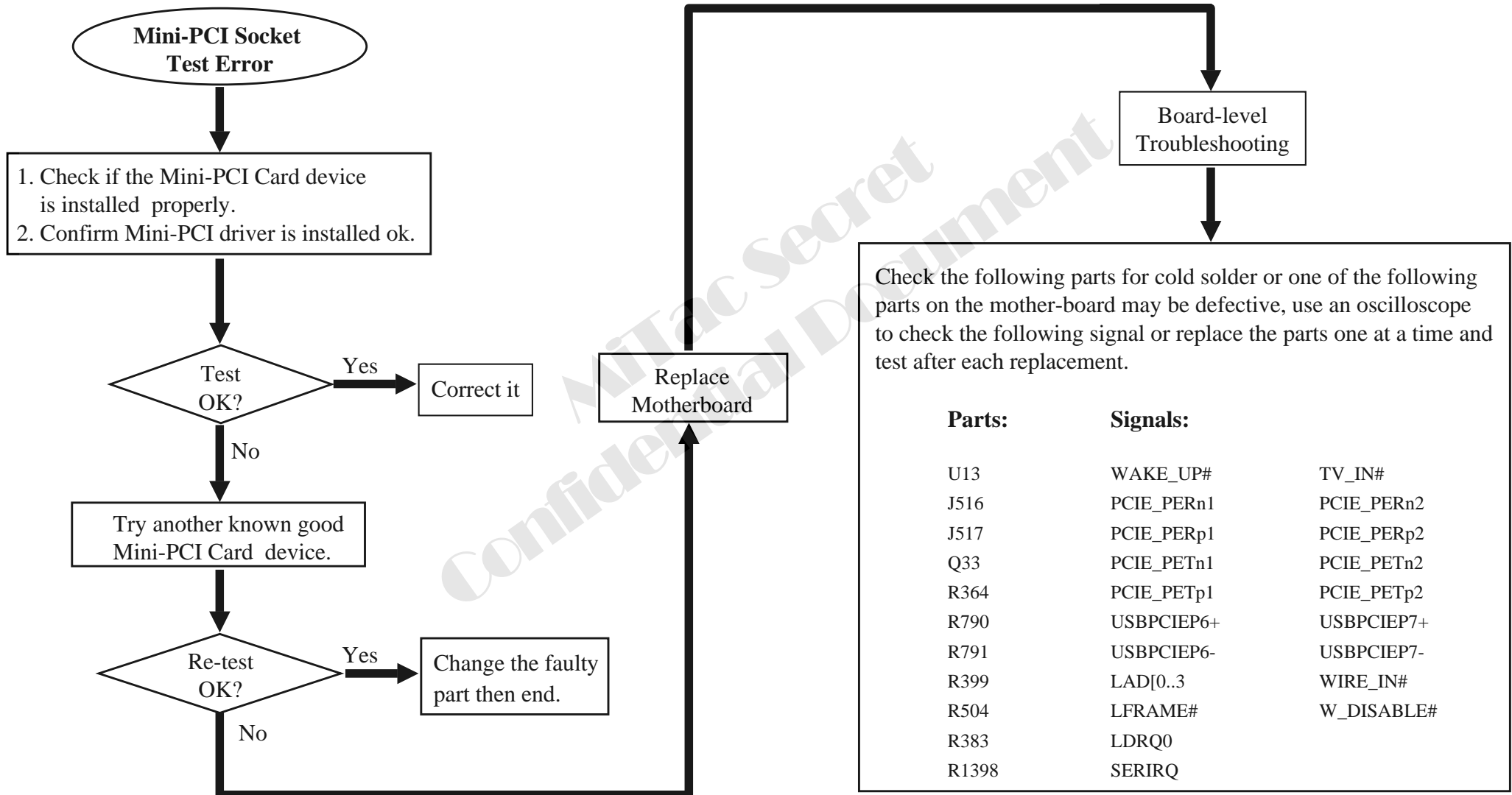

8224 N/B Maintenance

8.13 Mini-PCI Socket Test Error-2

An error occurs when a Wireless LAN Card device is installed.

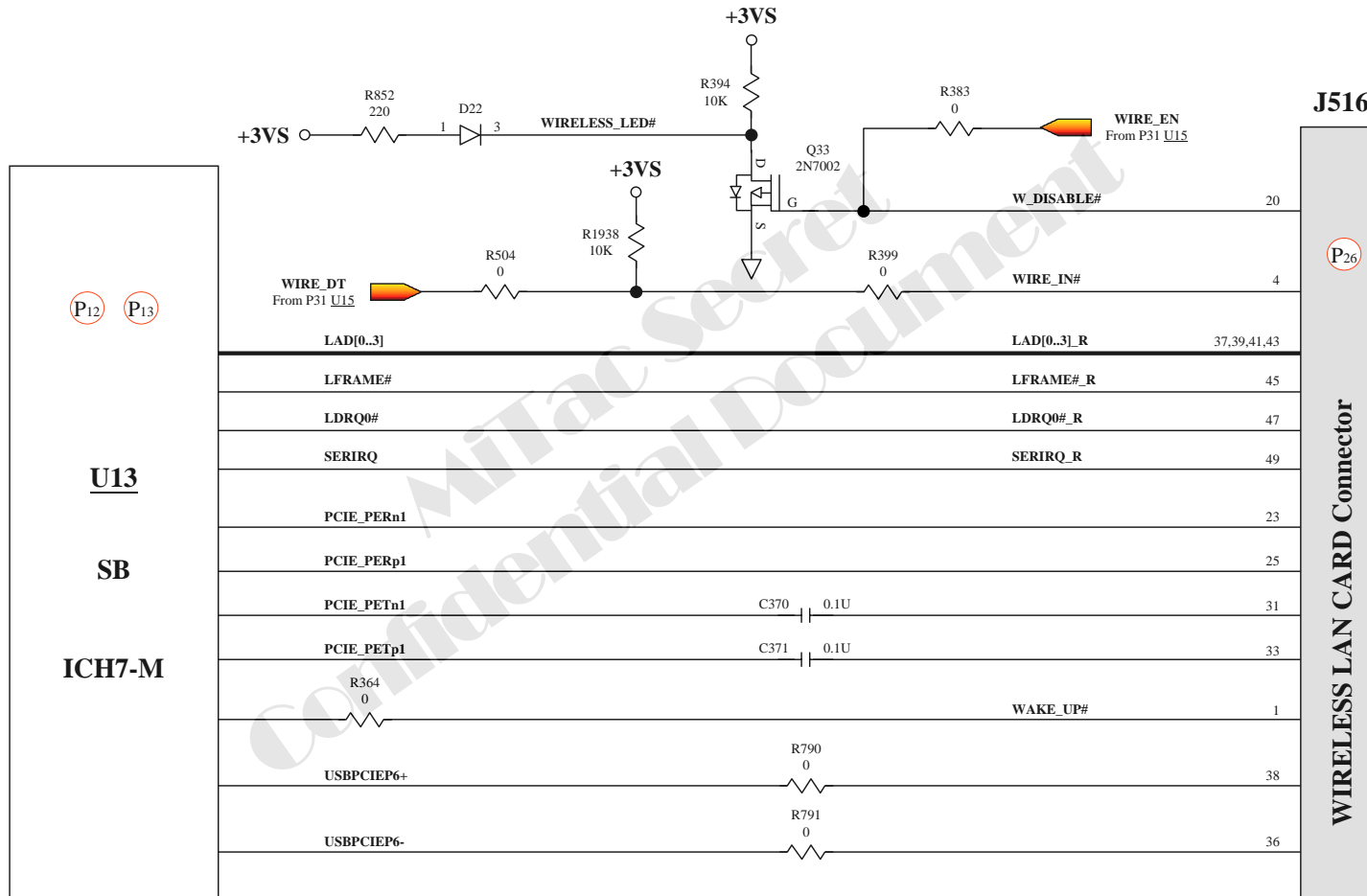

8224 N/B Maintenance

8.13 Mini-PCI Socket Test Error-3

An error occurs when a TV Card device is installed.

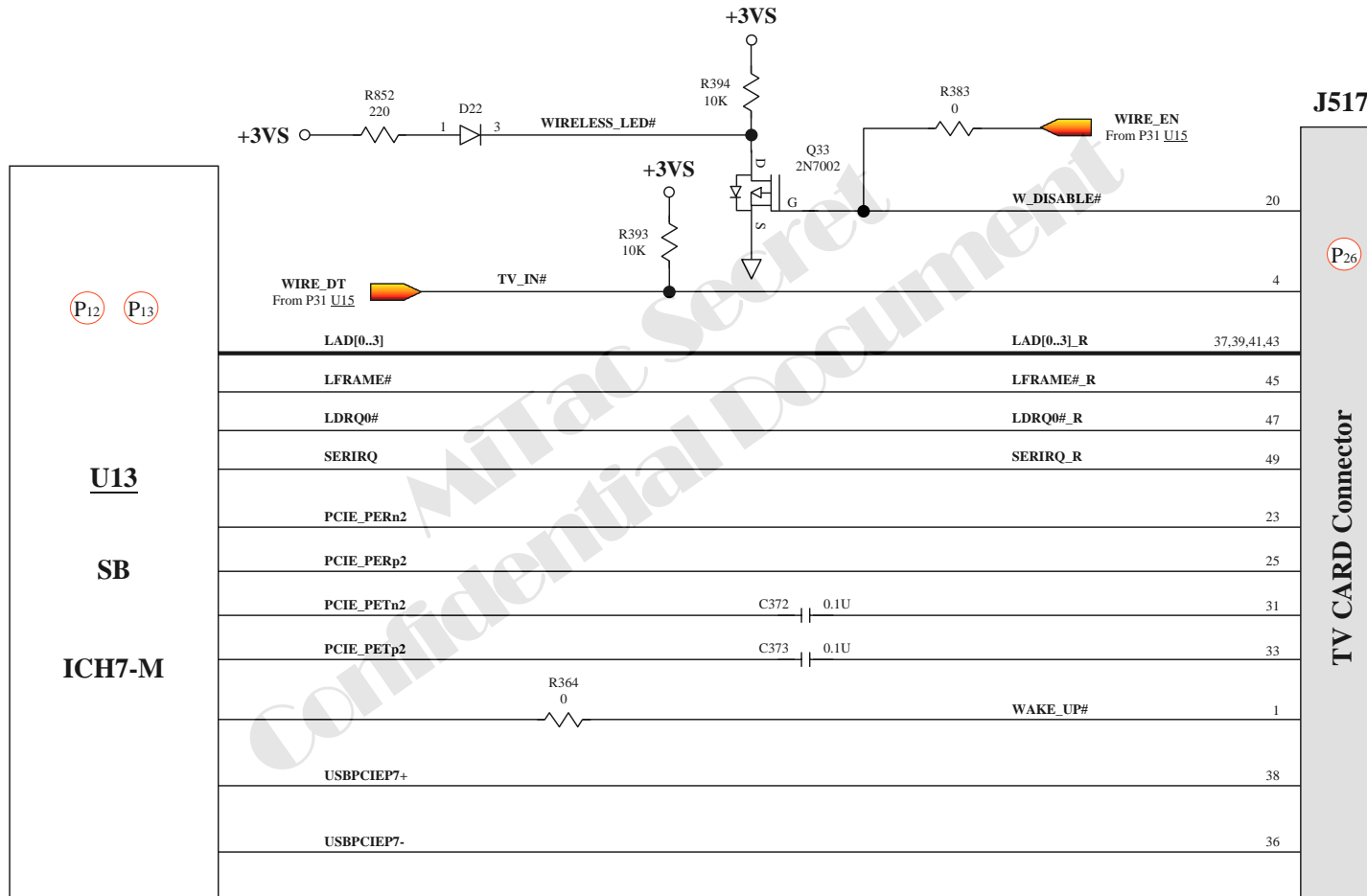

8224 N/B Maintenance

8.14 CardReader & IEEE1394 Socket Test Error-1

An error occurs when the CardReader & IEEE1394 device is installed.

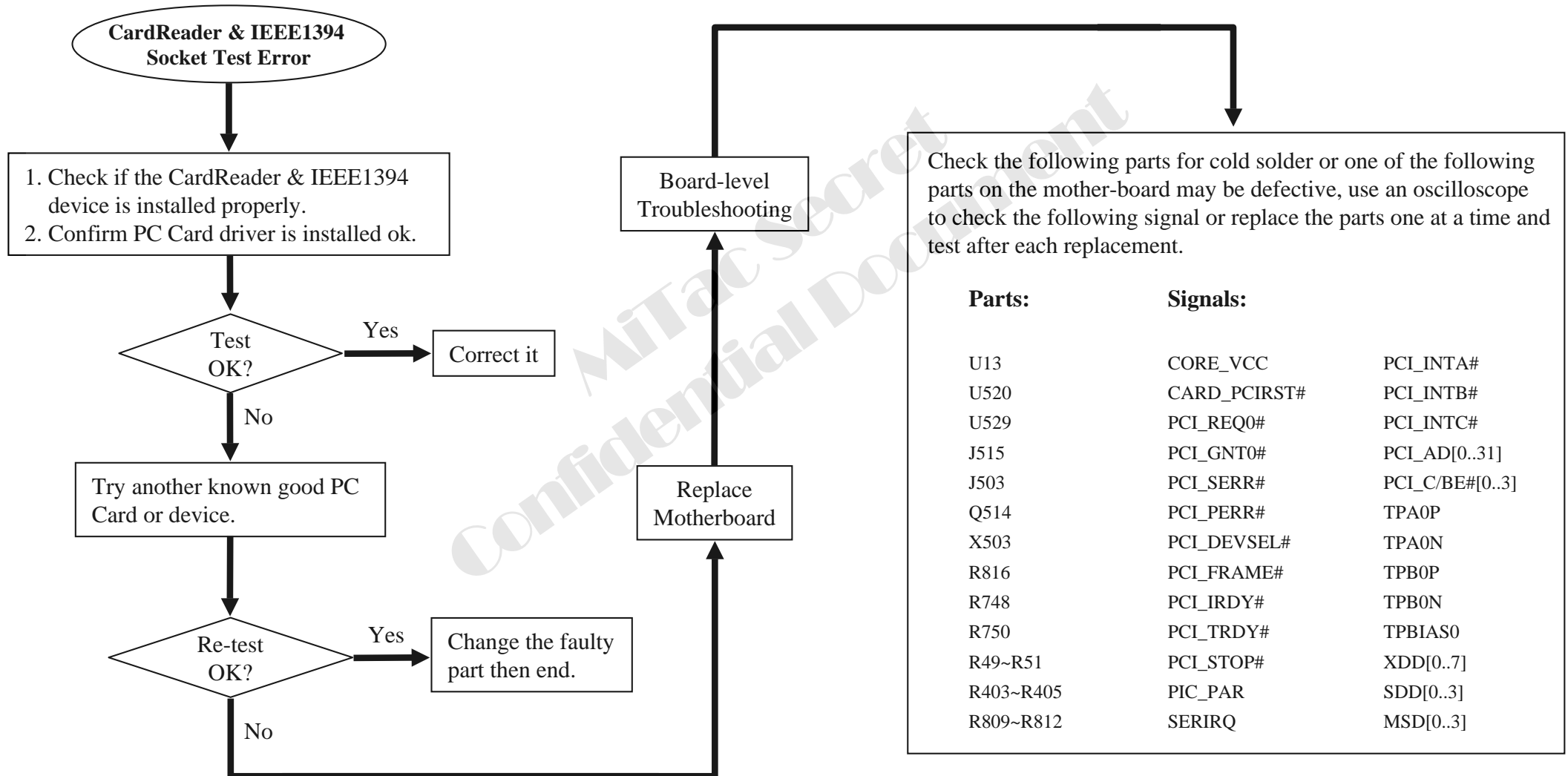

8224 N/B Maintenance

8.14 CardReader & IEEE1394 Socket Test Error-2

An error occurs when the CardReader & IEEE1394 device is installed.

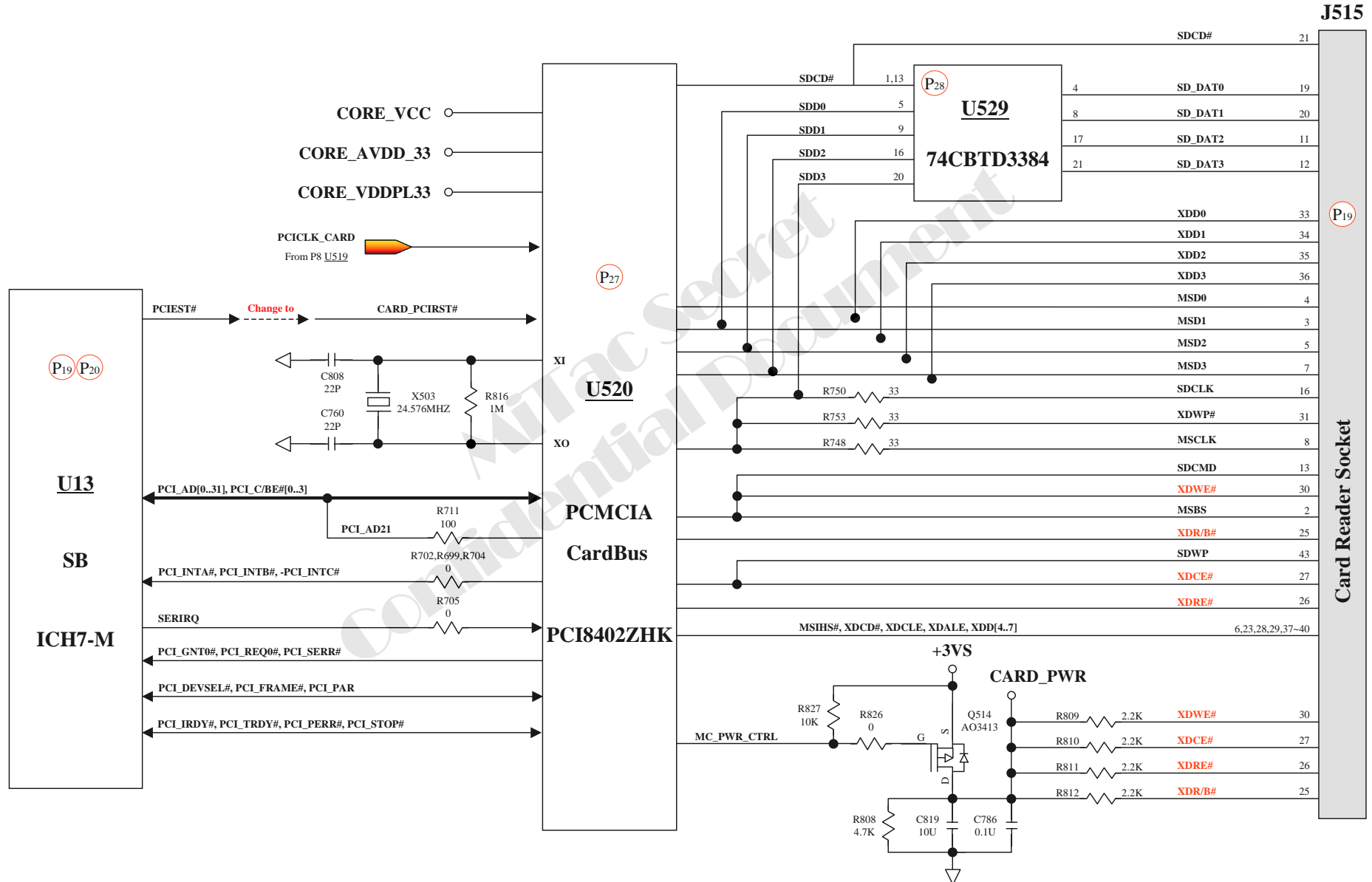

8224 N/B Maintenance

8.14 CardReader & IEEE1394 Socket Test Error-3

An error occurs when the CardReader & IEEE1394 device is installed.

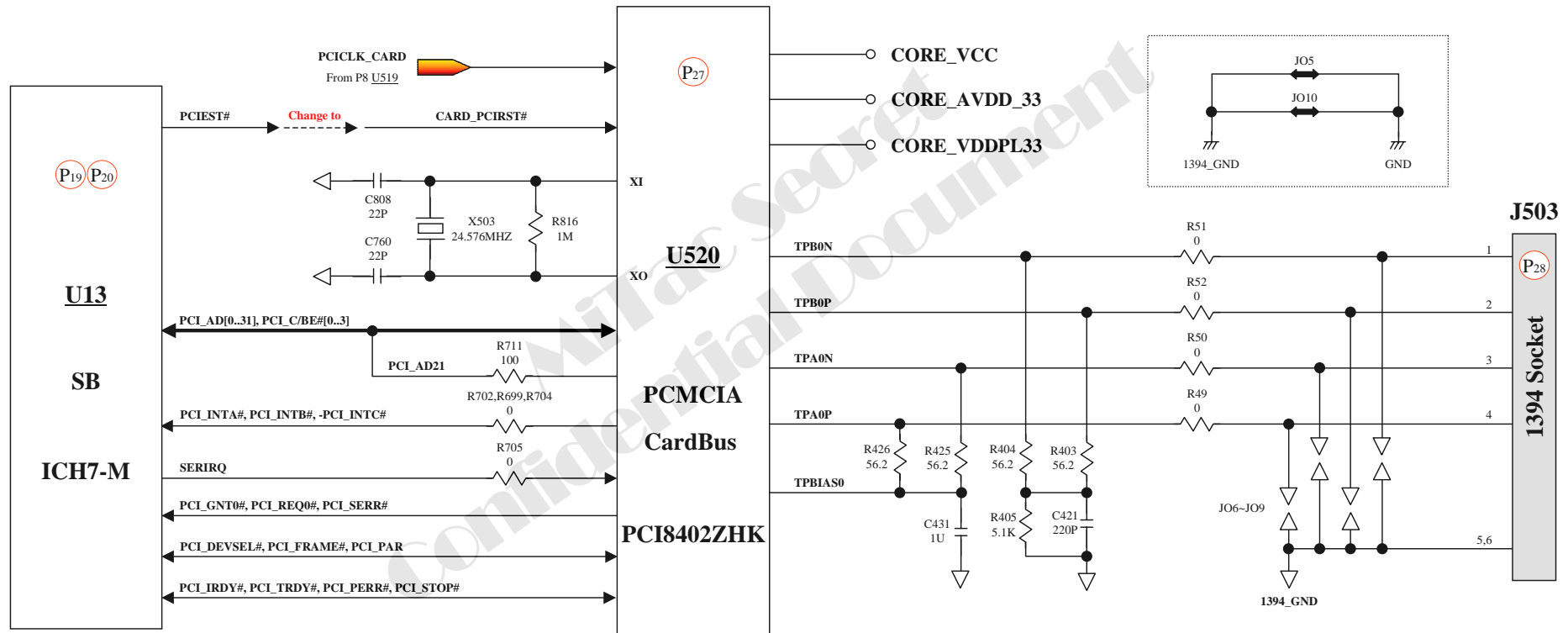

8224 N/B Maintenance

8.15 Audio Test Error-1

No sound from speaker after audio driver is installed.

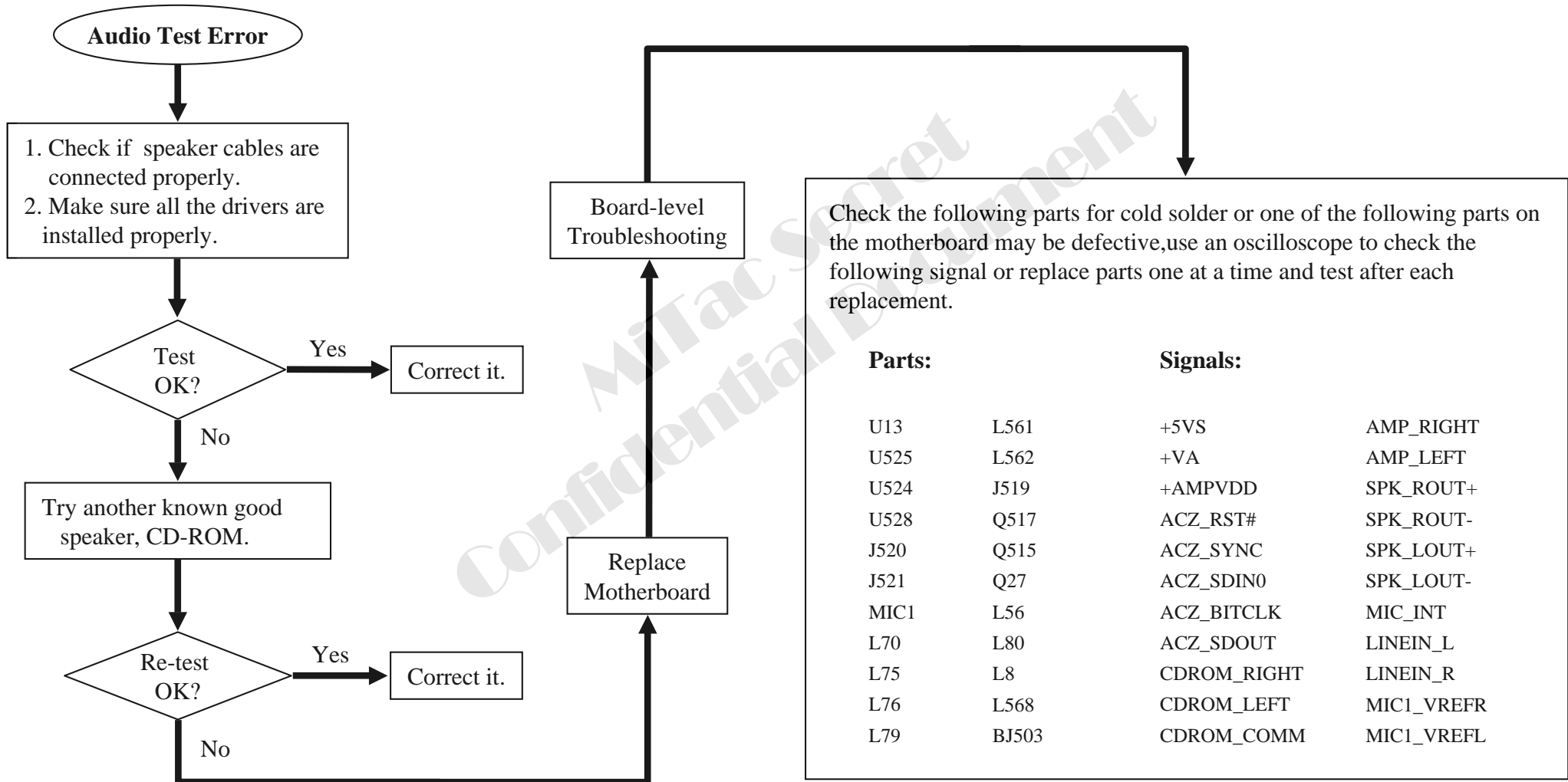

8224 N/B Maintenance

8.15 Audio Test Error-2 (Audio In)

No sound from speaker after audio driver is installed.

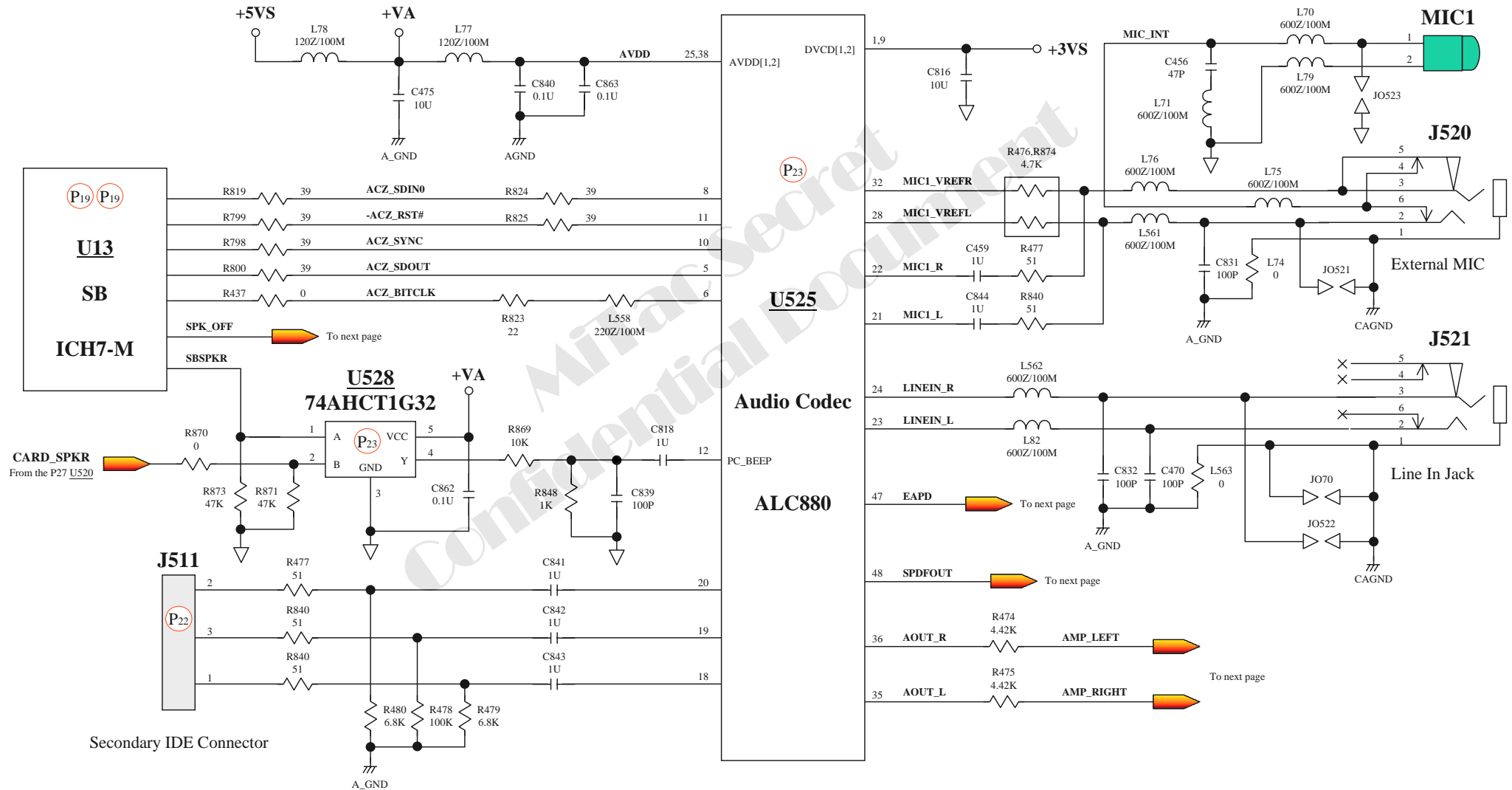

8224 N/B Maintenance

8.15 Audio Test Error-3 (Audio Out)

No sound from speaker after audio driver is installed.

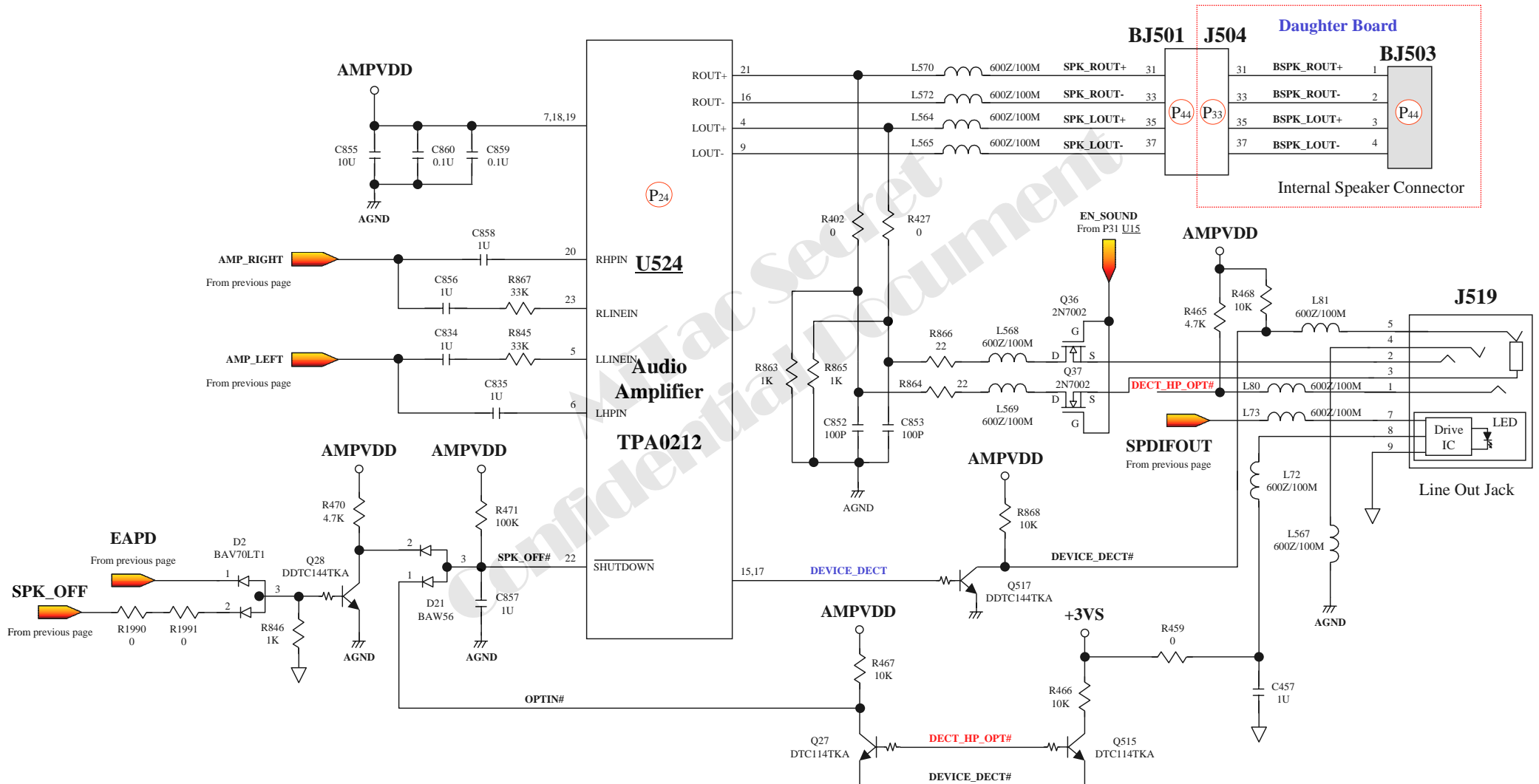

8224 N/B Maintenance

8.16 LAN Test Error-1

An error occurs when a LAN device is installed.

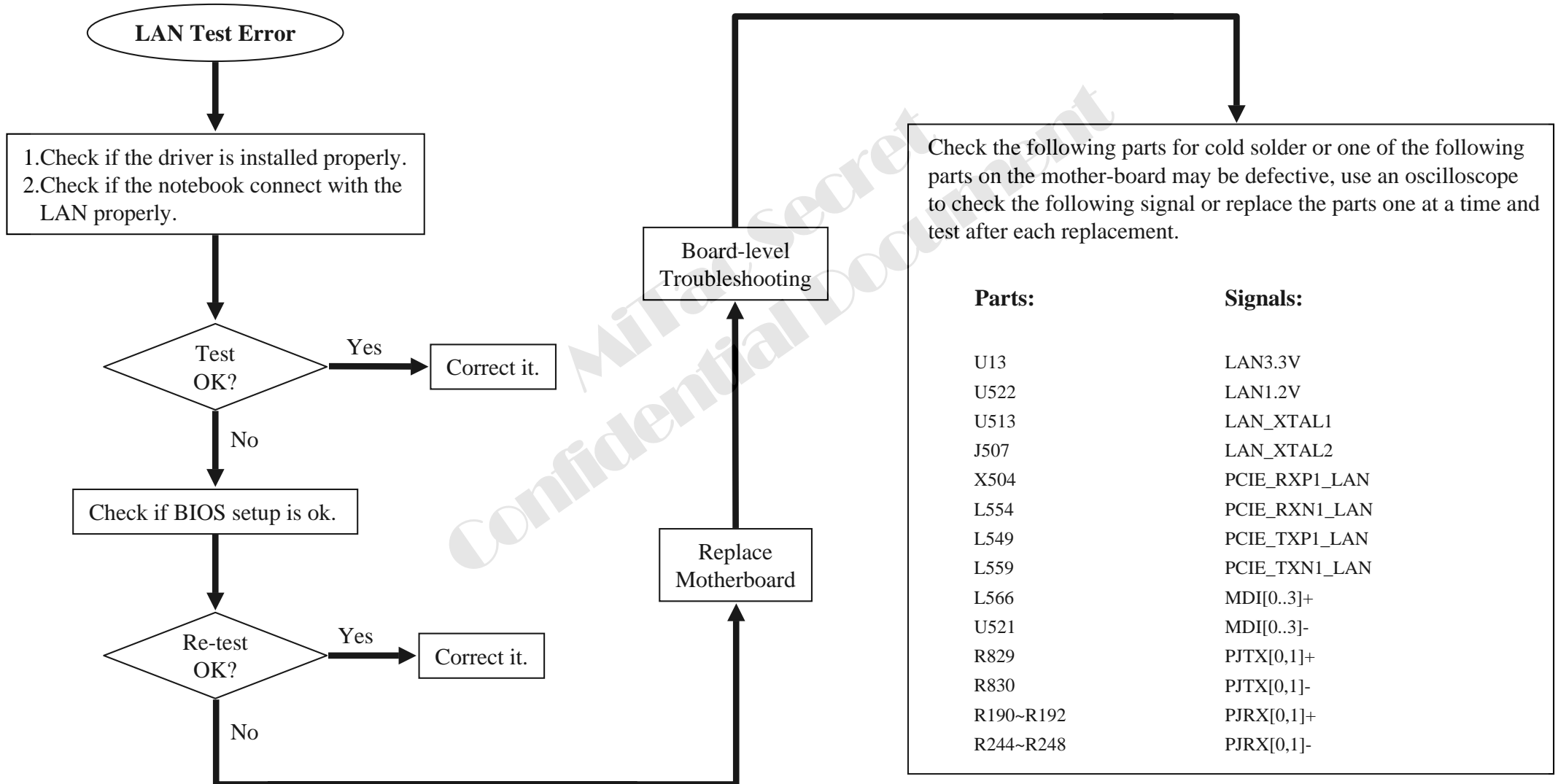

8224 N/B Maintenance

8.16 LAN Test Error-2

An error occurs when a LAN device is installed.

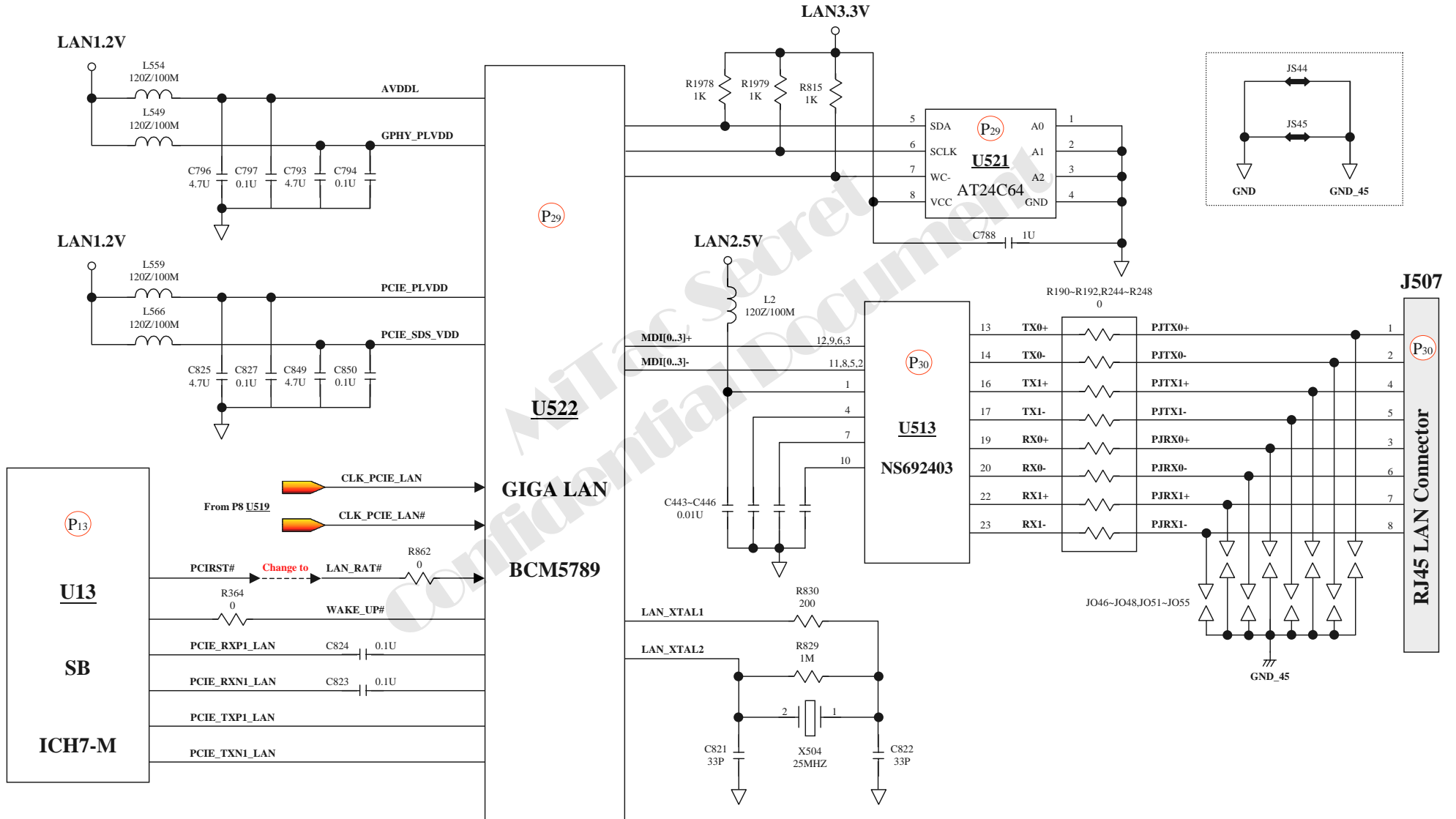

8224 N/B Maintenance

9. Spare Parts List - 1

Part Number	Decription	Location(S)
526280442004	LT AVIO;8224D1BenQY / G5 A1 /0F08	
323780440002	TF041-DDR2 SO-DIMM;NT512T64UH8A1	
324180787343	BFM BENQ IC,CPU;DUAL-CORE,YONAH	
346804400034	TF041-INSULATOR;HOUSING,DTV,8224	
412804400005	TF041-BFM-BENQ; PCB ASSY, WLAN C	
242802200010	TF041-LABEL,SKYPE,CARTON,45.K560	
561880220014	TF041-SINGLE PAGE;BENQ SKYPE RED	
412600000048	TF041-PCB ASSY;BLUETOOTH,GUBTCR4	
242804400033	TF041-LABEL;BLUE TOOTH,BENQ,8224	
370102030304	TF041-SPC-SCREW;M2L3,K-HD(+1)D3.	
422804400006	TF041-WIRE ASSY;BLUETOOTH,ISMT,8	
413000021302	TF041-BFM-BenQ;TFT LCD;B141EW01	
340804400007	TF041-COVER ASSY;LCD,8224	
340804400008	TF041-HOUSING ASSY;LCD,8224	
340804400009	TF041-SPEAKER ASSY;VECO,8224	
342804400006	TF041-HINGE;R,SINHER,8224	
342804400007	TF041-HINGE;L,SINHER,8224	
346804400011	TF041-INSULATOR;INVERTER,8224	
370102030304	TF041-SPC-SCREW;M2L3,K-HD(+1)D3.	
370102610409	TF041-SPC-SCREW;M2.6L4,K-HD,T0.8	
370102610604	TF041-SPC-SCREW;M2.6L6,K-HD(+1)D	
371102010263	TF041-SCREW;M2L2.5,K-HD(+1),D4.0	
422804400007	TF041-WLAN ASSY,LCD HOUSING,8224	
242664800093	TF041-LABEL;CAUTION,INVERT BD,PI	
422804400012	TF041-WIRE ASSY,LCD AUB141EW01,I	

Part Number	Decription	Location(S)
422804400011	TF041-WIRE ASSY;INVERTER,ISMT,82	
345803700003	TF041-RUBBER;COVER,LCD,8090	
412804400001	TF041-PCB ASSY;D/A BD,8224,GPU,P	
365350000009	LF-SOLDER WIRE;SN96.5/AG3.0/CU0.	
411804400017	TF041-PWA;D/A BD,8224,DA-1A08-N0	
271071102313	TF041-TH-RES;1K ,1/16W,5% ,060	R11
271071104310	TF041-TH-RES;100K ,1/16W,5% ,060	R7
271071131103	TF041-TH-RES;130 ,1/16W,1% ,060	R14A
271071202304	TF041-TH-RES;2K ,1/16W,5% ,060	R12
271071304103	TF041-TH-RES;301K ,1/16W,1% ,060	R13,R3
271071333305	TF041-TH-RES;33K ,1/16W,5% ,060	R2
271071470103	TF041-TH-RES;4.32K,1/16W,1% ,060	R10
271071563102	TF041-TH-RES;56K ,1/16W,1% ,060	R6
271071753302	TF041-TH-RES;75K ,1/16W,5% ,060	R8
271072433101	TF041-TH-RES;43.2K,1/10W,1% ,060	R1
271072474102	TF041-TH-RES;470K ,1/10W,1% ,060	R4,R5,R9
272012016401	TF041-TH-CAP;1U,CR,16V,10%,1206,	C14A,C14B
272023475402	TF041-TH-CAP;4.7U ,25V ,10%,1210	C1
272030680404	TF041-TH-CAP;68P ,3KV,10%,1808,	C20
272071105411	TF041-TH-CAP;1U ,10V ,10%,0603,X	C10,C4
272071334404	TF041-TH-CAP;0.33U ,10V ,10%,060	C2
272072105403	TF041-TH-CAP;0.1U ,CR,16V,10%,0	C12,C17
272072683408	TF041-TH-CAP;0.068U ,16V ,10%,06	C16
272073104712	TF041-TH-CAP;0.1U,25V,10%,0603,X	C7
272073105404	TF041-TH-CAP;1UF ,25V,10%,0603,	C6

8224 N/B Maintenance

9. Spare Parts List - 2

Part Number	Decription	Location(S)
272073223408	TF041-TH-CAP;0.022U,CR,25V ,10%,	C9
272075103415	TF041-TH-CAP;0.01U ,50V,10%,060	C11,C13,C3,C8
272075222407	TF041-TH-CAP;2200P,50V ,10%,0603	C5
272075472503	TF041-TH-CAP;4700P,50V ,+ -20%,0	C15A
272990100302	TF041-TH-CAP;10P,3000V,+ 5%,NPO	C19
273001050217	TF041-TH-XFMR;CI8.5,25T/2150T,29	T1
281101010003	TF041-TH-IC;MP1010BEM-LF,CCFL CT	U1
291000020229	TF041-TH-CON;HDR,MA,2P*1,3.5MM,R	J2
295000010216	TF041-TH-FUSE;FAST,1.25A,63V,120	F1
316686500004	TF041-PCB;PWA-GHARIAL/INVERTER B	R0B
361200003064	TF041-SOLDER PASTE;SN96.5/AG3.0/	
291000000717	TF041-TH-CON;1.25mm R/A WTB,7P,S	J1
242804400009	TF041-TH-LABEL;BAR CODE,20*10,BL	
340804400001	TF041-COVER ASSY;8224	
340804400010	TF041-COVER ASSU;KB,8224	
342803700011	TF041-ST ANDOFF;IO DVI,8090	
344804400004	TF041-DUMMY CARD;NEW CARD,8224	
370102030304	TF041-SPC-SCREW;M2L3,K-HD(+1)D3.	
370102610409	TF041-SPC-SCREW;M2.6L4,K-HD,T0.8	
370102610604	TF041-SPC-SCREW;M2.6L6,K-HD(+1)D	
370102611804	TF041-SPC-SCREW;M2.6L18,k-HD(+1)	
371102010263	TF041-SCREW;M2L2.5,K-HD(+1),D4.0	
422804400002	TF041-FFC;TP,8224	
340804400020	Housing ASSY;SPUTTER,8224	
340804400022	COVER ASSY;HDD,SPUTTER,8224	

Part Number	Decription	Location(S)
340804400021	COVER ASSY;CPU,SPUTTER,8224	
346804400036	TF041-INSULATOR;COVER,8224	
346804400032	TF041-INSULATOR;SCREW,KB,8224	
422804400005	TF041-WIRE ASSY;MDC,ISMT,8224	
242682800106	LABEL;SCREW,HDD COVER,BEN Q,8089	
411804400018	TF041-PWA;PWA-8224,HYNIX,945PM+	
411804400020	TF041-PWA;PWA-8224,HYNIX,945PM+	
270110000011	TF041-TL-THERMISTOR;10K,1%,0603,	PR571
270110000017	TF041-TH-THERMISTOR;470K,5%,0603	PR48
271002000312	TF041-TH-RES;0 ,1/10W,5% ,080	R163
271012000308	TF041-TH-RES;0 ,1/8W,5% ,1206	D19,PR4
271045029102	TF041-TH-RES;.02 ,1W,1%,2512,SMT	PR17
271061000003	TF041-TH-RES;0 ,1/16W,0402,SM	PR31,PR34,PR36,PR37,PR38,PR39
271061100103	TF041-TH-RES;10,1/16W,1%,0402,SM	PR519,PR524,PR525,PR541,PR58,PR59
271061101109	TF041-TH-RES;100 ,1/16W,1% ,040	R186,R387,R598,R611,R615,R628,PR572
271061102113	TF041-TH-RES;1K ,1/16W,1% ,040	R123,R139,R166,R167,R1978,R1979
271061103114	TF041-TH-RES;10K ,1/16W,1% ,040	PR33,PR522,PR523,PR533,PR536,PR537
271061104108	TF041-TH-RES;100K ,1/16W,1% ,040	PR508,R1964,R20,R2019,R2035,R400
271061106308	TF041-TH-RES;10M ,1/16W,5% ,040	R378,R441
271061201107	TF041-TH-RES;200 ,1/16W, 1%,040	R185,R2068,R830
271061202104	TF041-TH-RES;2K ,1/16W,1% ,040	R140,R168
271061220308	TF041-TH-RES;22 ,1/16W,5% ,040	R2057,R447,R450,R679,R680,R681
271061221318	TF041-TH-RES;220 ,1/16W, 5%,040	R1943,R1944,R487,R493,R495,R85
271061222104	TF041-TH-RES;2.2K,1/16W,1%,0402,	R29,R30,R691,R696,R725,R735,R77
271061240102	TF041-TH-RES;24.9,1/16W,1% ,0402	R330,R422,R609,R616,R666,R772

8224 N/B Maintenance

9. Spare Parts List - 3

Part Number	Decription	Location(S)
271071103117	TF041-TH-RES;10.2K,1/16W,1%,0603	PR567
271071104108	TF041-TH-RES;100K ,1/16W,1% ,060	PR1,PR516,PR561,PR562,PR7,PR7
271071113115	TF041-TH-RES;11.8K ,1/16W,1% ,06	PR539
271071122105	TF041-TH-RES;1.2K ,1/16W,1% ,060	PR14,PR25,PR551,PR568,PR62,PR
271071124117	TF041-TH-RES;124K ,1/16W,1% ,060	PR9
271071124118	TF041-TH-RES;1.24K,1/16W,1% ,060	R833
271071133114	TF041-TH-RES;13.7K,1/16W,.,1%,060	PR503
271071141104	TF041-TH-RES;1.47K,1/16W,1% ,060	R171
271071152107	TF041-TH-RES;1.5K ,1/16W,1% ,060	R288
271071154115	TF041-TH-RES;150K ,1/16W,1% ,060	PR23,PR537
271071178112	TF041-TH-RES;1.78K,1/16W,1% ,060	PR507
271071181103	TF041-TH-RES;180 ,1/16W,1% ,060	PR548
271071203106	TF041-TH-RES;20K ,1/16W,1% ,060	PR564,R674
271071203107	TF041-TH-RES;20K ,1/16W,.,1%,060	PR13
271071205313	TF041-TH-RES;2M ,1/16W,5% ,060	PR12
271071213104	TF041-TH-RES;21.5K,1/16W,1% ,060	PR49,PR64
271071220308	TF041-TH-RES;22 ,1/16W,5% ,060	R389,R391,R435,R743,R744
271071221103	TF041-TH-RES;221 ,1/16W,1% ,060	R612,R614
271071228306	TF041-TH-RES;2.2 ,1/16W,5% ,060	PR50,PR67,R362,R685
271071241105	TF041-TH-RES;243,1/16W,1%,0603,S	R152
271071242104	TF041-TH-RES;2.49K,1/16W,1% ,060	PR514
271071251101	TF041-TH-RES;255 ,1/16W,1% ,0603	R202
271071292101	TF041-TH-RES;2.94K ,1/16W,1% ,06	PR542
271071301114	TF041-TH-RES;300 ,1/16W,1% ,0603	PR35
271071332102	TF041-TH-RES;3.3K ,1/16W,1% ,060	PR26

Part Number	Decription	Location(S)
271071332313	TF041-TH-RES;332K ,1/16W,1% ,060	R821
271071391103	TF041-TH-RES;390,1/16W,1% ,0603,	R784
271071432113	TF041-TH-RES;4.3K ,1/16W,1% ,060	PR517,R686
271071452101	TF041-TH-RES;4.53K ,1/16W,1% ,06	PR545
271071472309	TF041-TH-RES;4.7K ,1/16W,5% ,060	PR2,PR3,PR515
271071490103	TF041-TH-RES;499 ,1/16W,1% ,060	R128,R130,R162
271071492102	TF041-TH-RES;4.99K,1/16W,1% ,060	PR565
271071494101	TF041-TH-RES;499K ,1/16W,1% ,060	PR69
271071512103	TF041-TH-RES;5.1K ,1/16W,1% ,060	PR44,PR543,PR544
271071561104	TF041-TH-RES;560 ,1/16W,1% ,060	PR28
271071562815	TF041-TH-RES;56.2 ,1/16W,1% ,060	R403,R404,R425,R426
271071612101	TF041-TH-RES;6.19K,1/16W,1% ,060	PR513
271071682103	TF041-TH-RES;6.8K ,1/16W,1% ,060	PR538,PR553
271071683103	TF041-TH-RES;68.1K ,1/16W,1% ,06	PR552
271071711101	TF041-TH-RES;715 ,1/16W,1% ,0603	R597
271071754102	TF041-TH-RES;750K,1/16W,1% ,0603	PR563
271071800101	TF041-TH-RES;80.6 ,1/16W,1% ,060	R621,R622
271071974102	TF041-TH-RES;976K ,1/16W,1% ,060	PR504
271072394102	TF041-TH-RES;392K ,1/10W,1% ,060	PR10
271072562101	TF041-TH-RES;56.2K ,1/10W,1% ,06	PR554
271611103305	TF041-TH-RP;10K*4 ,8P ,1/16W,5%	RP2
271621103306	TF041-TH-RP;10K*8 ,10P,1/32W,5%	RP502
271621472306	TF041-TH-RP;4.7K*8,10P,1/32W,5%	RP501
272001105410	TF041-TH-CAP;1U ,10%,10V ,0805	PC537,PC56
272001106514	TF041-TH-CAP;10U,6.3V,+ -20%,080	C104,C1465,C258,C26,C271,C277,C

8224 N/B Maintenance

9. Spare Parts List - 4

Part Number	Decription	Location(S)
272001475704	TF041-TH-CAP;4.7U ,CR,10V ,+80-2	PC15
272002105709	TF041-TH-CAP;1U ,CR,16V , -20+80	PC13
272002224405	TF041-TH-CAP;0.22U,16V,0805,10%,	PC41,PC68
272002225705	TF041-TH-CAP;2.2U ,CR,16V ,+80-2	PC29,PC67
272005105402	TF041-TH-CAP;0.1U,CR,50V,10%,X7R	PC33,PC524,PC557,PC559
272011106417	TF041-TH-CAP;10U,10V,+/-10%,1206	PC536,PC66
272013106504	TF041-TH-CAP;10U,25V,+/-20%,1206	PC1,PC2,PC30,PC31,PC37,PC49,PC
272030102411	TF041-TH-CAP;1000P,2KV,10%,1808,	C301,C447,C448
272071106503	TF041-TH-CAP;10UF,+20%,6.3V,060	C624,C848
272071225406	TF041-TH-CAP;2.2U ,CR,6.3V ,10%,	C25,C256,C27,C273,C28,C380,C38
272071475403	TF041-TH-CAP;4.7U,6.3V,10%,0603,	C274,C391,C396,C415,C453,C465,C
272072105403	TF041-TH-CAP;0.1U ,CR,16V,10%,0	PC525
272072153405	TF041-TH-CAP;0.015U ,CR,16V,10%,	PC545
272072224405	TF041-TH-CAP;0.22U ,16V ,10%,060	PC538,PC539,PC551
272073104713	TF041-TH-CAP;0.1U ,25V,+80-20%,	PC51,PC511
272073105404	TF041-TH-CAP;1UF ,25V,10%,0603,	PC24,PC514,PC550
272073223408	TF041-TH-CAP;0.022U,CR,25V ,10%,	PC54
272075102419	TF041-TH-CAP;1000P,CR,50V,10%,06	PC11,PC16,PC3,PC517,PC528,PC5
272075103414	TF041-TH-CAP;0.01U ,CR,50V ,10%,	CI05,PC14,PC4,PC510,PC513,PC5
272075104710	TF041-TH-CAP;0.1U ,50V,+80-20%,	CI6,C873,PC12,PC17,PC34,PC5,PC
272075222704	TF041-TH-CAP;2200P,50V ,+/-20%,0	PC53
272101016401	TF041-TH-CAP;.1U ,CR,10V,10%,04	C328,C329,C330,C331,C332,C333
272101105705	TF041-TH-CAP;1U ,CR,6.3V ,80-2	CI15,CI16,CI18,CI19,CI20,CI21,C
272101224702	TF041-TH-CAP;0.22U ,10V ,+80-20%	C2,C252,C253,C254,C270,C588
272101473407	TF041-TH-CAP;0.047U,10V,10%,0402	C378,C399,C707,C708,C709,C711,C

Part Number	Decription	Location(S)
272101474703	TF041-TH-CAP; 0.47U ,CR,10V,+80-	C257,C281,C591,C592,C594,C602,C
272102223409	TF041-TH-CAP;0.022U,16V ,+/-10%,0	C243,C245,C246,C249,C265,C266,C
272103330403	TF041-TH-CAP;33P ,25V ,+/-10%,0	C3,C4,C5,C821,C822
272105100307	TF041-TH-CAP;10P ,CR,50V ,5%,04	C101,C107,C109,C111,C398,C403,C
272105101404	TF041-TH-CAP;100P ,50V ,+ -10%,0	C1,C470,C530,C831,C832,C839,C85
272105102421	TF041-TH-CAP;1000P,CR,50V,10%,04	C10,C359,C367,C44,C543,C547,C67
272105103704	TF041-TH-CAP;0.01U ,50V,+80-20%,	C100,C14,C259,C302,C303,C304,C5
272105180308	TF041-TH-CAP;18P ,50V ,+/-5%,04	C432,C433
272105220404	TF041-TH-CAP;22P ,50V ,+ -10%,0	C408,C409,C760,C808,C817
272105221410	TF041-TH-CAP;220P ,CR,50V ,10%,0	C421,PC541
272105222503	TF041-TH-CAP;2200P,50V ,+/-20%,0	C568,C587
272105331303	TF041-TH-CAP;330P,CR,50V,5%,0402	PC554
272105392502	TF041-TH-CAP;3900P,50V,+/-20%,04	C423,C434,C435,C436
272105470403	TF041-TH-CAP;47P ,50V ,+ -10%,0	C146,C147,C471,C472,C868,C869
272105471408	TF041-TH-CAP;470P ,50V,10%,0402,	C113,C305,C307,C78
272105561302	TF041-TH-CAP;56P ,50V ,5%,0402,N	C716,C717
272431227404	TF041-TH-CAP;220U,2V,-35/+10%,H1	PC45,PC46,PC48,PC58
272431477003	TF041-TH-CAP;470U,2.5V,2R5TPE470	C308,C609
272625470405	TF041-TH-CP;47P*4 ,8P,50V ,10%,1	CP501,CP502
273000500184	TF041-TH-FERRITE CHIP;600OHM/100	L10,L3,L561,L562,L564,L565,L570
273000500267	TF041-TH-CHOKE COIL;400uH MIN,12	L532
273000500291	TF041-TH-CHOKE COIL;0.36UH,1.1mo	PL512,PL513
273000500315	TF041-TH-CHOKE COIL;1UH,+20%,3.	PL502
273000610041	TF041-TH.FERRITE CHIP;120OHM/100	L13,L14,L27,L28,L29,L38,L40,L41
273000994009	TF041-TH-INDUCTOR;PCMC063T -4R7MN	PL2,PL503,PL516,PL517

8224 N/B Maintenance

9. Spare Parts List - 5

Part Number	Decription	Location(S)
273001050278	TF041-TH-XSFORMER;10/100/1000BAS	U513
274011431454	TF041-TH-XTAL;14.318MHZ,32PF,50P	X502
274013275401	TF041-TH-XTAL;32.768KHZ,20PPM,12	X3
281307085005	TF041-TH-IC;NC7SZ08P5,2-INPUT &	U1
282574008013	TF041-TH-IC;74AHC08,QUAD 2-I/P A	U9
282574108008	TF041-TH-IC;74AHC1G08,SINGLE AND	U502,U505
282574132012	TF041-TH-IC;74AHCT1G32,SINGLE OR	U528
283480440007	TF041-TH-IC;EEPROM,AT24C64,64K,S	U521
283780430003	TF041-TH-IC;HY5PS561621AFP-25,HY	U5,U507,U509,U515,U516,U6,U7,U
284500056001	TF041-TL-IC;ATI-M56P,33X33MM,BGA	U511
284501032008	TF041-TH-IC;ADM1032ARMZ-2;MSOP;8	U508
284508402001	TF041-TH-IC;PCI8402ZHK SINGLE SO	U520
284509310001	TF041-TH-IC;ICS9LPR310, LOW POWE	U519
284510321002	TF041-TH-IC;ADM1032ARZ-1,TEMPERA	U510
481804400010	TF041-F/W ASSY;GAZELLE,945PM+ DI	U15
286100393013	TF041-TH-IC;LMV393,DUAL COMPARTO	PU504
286206238004	TF041-TH-IC;TSOP6238,IR,4P,SMT	U527
286300594004	TF041-TH-IC;TL594C,PWM CONTROL,S	PU501
286300692001	TF041-TH-IC;G692L293T Cuf,RESET C	U16
286302231002	TF041-TH-IC;TPS2231,POWER INTERF	U12
286302996002	TF041-TH-IC;G2996P1U,DDR,GMT,SOP	PU6
286304315001	TF041-TH-IC;SC431LCSK-.5,5%,ADJ	PQ522
286306208002	TF041-TH-IC;ISL6208CBZ-T,PWM DRI	PU3,PU5
286306227003	TF041-TH-IC;ISL6227CAZ, PWM CONT	PU4,PU502
286306260002	TF041-TH-IC;ISL6260,IMVP-VI,QFN4	PU503

Part Number	Decription	Location(S)
286309701004	TF041-TH-IC;RT9701PB,POWER DISTR	U517
286396625001	TF041-TH-IC;G966-25ADJF1U,LDO,GM	PU2
288100032014	TF041-TH-DIODE;BAS32L,VRRM75V,ME	D3,D508,PD508
288100034010	TF041-TH-DIODE;SCD34,40V,3A,2010	PD1,PD10,PD13,PD501,PD503
288100054034	TF041-TH-DIODE;BAT54,30V,200mA,S	D506,D507
288100054035	TF041-TH-DIODE;BAT54C,SCHOTTKY D	D15,D16
288100056022	TF041-TH-DIODE;BAW56,70V,215mA,S	D21,PD12,PD505
288100140012	TF041-TH-DIODE;SCSI40PL,40V,1A,S	PD5
288100530009	TF041-TH-DIODE;B0530WS-7-F,0.5A,	PD16
288100541004	TF041-TH-DIODE;BAT54ALT1,COM. AN	D504
288100701003	TF041-TH-DIODE;BAV70LT1,70V,225M	D2,D503,D505
288104148020	TF041-TH-DIODE;RLS4148,200MA,500	D1,D7
288105524005	TF041-TH-DIODE;BZV55-C2V4,ZENER,	PD11,PD14,PD506,PD509,PD510,F
288200069011	TF041-TH-TRANS;BCP69,NPN,SOT-223	Q516
288200114010	TF041-TH-TRANS;DTC114TKA,10K,N-M	Q27,Q515
288200144027	TF041-TH-TRANS;DDTC144WCA,NPN,SO	Q23,Q35
288200144028	TF041-TH-TRANS;DDTC144TCA,NPN,SO	Q1,Q13,Q14,Q17,Q41,Q509,Q511,Q
288200144029	TF041-TH-TRANS;DT C144WK,NPN,SOT-	PQ506
288200144030	TF041-TH-TRANS;DDTC144TKA,N-MOSF	Q15,Q18,Q19,Q20,Q22,Q28,Q39,Q4
288200144034	TF041-TH-TRANS;DDTA144WKA,NPN,SM	PQ5
288200301017	TF041-TH-TRANS;FDV301N_NL,N-CHAN	Q502,Q512
288202222021	TF041-TH-TRANS;PMBT2222A,NPN,SOT	PQ501
288203413002	TF041-TH-TRANS;AO3413,P-MOSFET,S	Q21,Q24,Q40,Q45,Q5,Q501,Q505,C
288203414002	TF041-TH-IC;TRANS;AO3414,N-CHANN	Q534,Q6,Q8
288204403011	TF041-TH-TRANS;AO4403,P-MOSFET,4	Q2,U2,U3

8224 N/B Maintenance

9. Spare Parts List - 6

Part Number	Decription	Location(S)
288204407002	TF041-TH-TRANS;AO4407,P-MOS,.010	PQ502,PQ508
288204702004	TF041-TH-TRANS;AO4702, N-MOSFET,	PQ504,PQ510,PQ521
288209003005	TF041-TH-TRANS;RSS090N03,N-MOSFE	PQ503,PQ509,PQ518
288213003005	TF041-TH-TRANS;RQA130N03,N-MOSFE	PQ3,PQ513,PQ514,PQ515,PQ516
288218003001	TF041-TH-TRANS;RQA180N03,N-MOSFE	PQ511,PQ512,PQ519,PQ520,PQ52
291000000071	TF041-TH-CON;EXPRESS CARD,EXP-26	J5
291000000713	TF041-TH-CON;MINI DIN,7P,R/A,C10	J506
291000001256	TF041-TH-CON;6P*2,0.8MM,BD/BD,88	J518
291000010229	TF041-TH-CON;HDR,MA,2P*1,1.25MM,	J513
291000010318	TF041-TH-CON;HDR,MA,3P*1,1.25MM,	J505
291000010440	TF041-TH-CON;HDR,MA,4P,1.25MM,H3	J508
291000013044	TF041-TH-CON;HDR,MA,15P*2,88107-	J1
291000021109	TF041-TH-CON;HDR,MA,11P*1,ACES,8	J2
291000250006	TF041-TH-CON;MEMORY CARD,4 IN 1,	J515
291000614798	TF041-TH-IC SOCKET;UPGA479M,479P	U506
291000622025	TF041-TH-DIMM SOCKET;DDR2,200P,0	J509
291000622026	TF041-TH-DIMM SOCKET;DDR2,200P,0	J510
291000810003	TF041-TH-CON;PHONE JACK,2 IN 1,7	J507
294011200514	TF041-TH-LED;BLUE,H0.55,LT ST-C19	D26,D27,D28,D29
294011200538	TF041-TH-LED;BLUE/ORG,19-22UYOSU	D22,D23,D24
295000010205	TF041-TH-FUSE;NORMAL,5A/24VDC,32	PF505
295000010207	TF041-TH-FUSE;FAST,3A,32V,1206,S	PF2,PF501,PF502
295000010210	TF041-TH-FUSE;2A,NORMAL,1206,SMT	PF3
295000010243	TF041-TH-FUSE;NANO,10A/125V,R451	PF503
297040100033	TF041-TH-SW;PUSH BUTTOM,5P,SPST,	SW1,SW2,SW3,SW5,SW6

Part Number	Decription	Location(S)
331000004081	TF041-TH-CON;IEEE1394,MA,4P*1,0.	J503
331000007073	TF041-TH-CON;BATT,C103A1-107A1-B	PJ501
331000008124	TF041-TH-CON;STEREO JACK,W/SPDIF	J519
331000024012	TF041-TH-CON;VGA-DVI-D,C16207-32	J501
331040004036	TF041-TH-CON;HDR,MA,4P*1,R/A,USB	J512
3310400050029	TF041-TH-CON;CDROM,C1240T-250A1-	J511
331720015093	TF041-TH-CON;D,FM,15P/3R,R/A,070	J502
291000000819	TF041-TH-CON;BLUE TOOTH CONNECTO	J522
342686000023	TF041-SMT SCREW;A40M20-50AS,HOOK	MTG501,MTG502
242600000565	TF041-LABEL;BLANK,11*5MM,COMMON	
242600000562	TF041-LABEL;6*6MM,GAL,BLANK,COMM	
242600000632	TF041-LABEL;27*7MM,XF-5811;POLYI	
242600000560	TF041-LABEL;PAL,20*5MM,COMMON	
242600000566	TF041-LABEL;BLANK,7MM*7MM,PRC	
361200001024	TF041-CLEANNER;YC-336,LIQUID,STE	
361200003064	TF041-SOLDER PASTE;SN96.5/AG3.0/	
316804400004	TF041-TH-PCB;PWA-8224/M+Daughter	R01
273000610042	TF041-TH,FERRITE CHIP;220OHM/100	L35,L558
273000500185	TF041-TH-FERRITE CHIP;130OHM/100	L1,L18,L19,L20,L4,L518,L8
273000130192	TF041-TH,FERRITE CHIP; 120OHM/10	L15,L16,L17,L2,L21,L22,L23,L24,
273000610048	TF041-TH,FERRITE ARRAY;120OHM/10	FA1,FA2
274012457449	TF041-TH-XTAL;24.576MHZ,16PF,30p	X503
274012500452	TF041-TH-XTAL;25MHZ,20PF,30PPM,8	X504
272431227014	TF041-TH-CAP;220uF,4V,+10/-30%,2	PC32,PC35,PC70
272603276503	TF041-TH-EC;27uF,25V,+/-20%,H5.7	PC505,PC534,PC561

8224 N/B Maintenance

9. Spare Parts List - 7

Part Number	Decription	Location(S)
273000996273	TF041-TH-INDUCTOR;33uH,2.3A,93mO	PL501
273000500187	TF041-TH-FERRITE CHIP;120OHM/100	PL1
284505789002	TF041-TH-IC;BCM5789KFBG;GIGA BIT	U522
286301117133	TF041-TH-IC;APL1117-25V,2.5V,1A,	U514
286305234006	TF041-TH-IC;FANS5234MTCX_NL,PWM C	PU1
288101040012	TF041-TH-DIODE;PDSI040,10A SCHOT	PD504
288204912002	TF041-TH-TRANS;AO4912,24mOHM ,SM	PQ517
291000001261	TF041-TH-CON;FPC/FFC,12P,88501-1	J3
291000150006	TF041-TH-CON;1.0mm FPC EASY ON C	J4
481804400009	TF041-F/W ASSY;GAZELLE,945PM+ DI	U14
272431227565	TF041-TH-CAP;220uF,2V, 20%,25m	C139,C346,C750,PC18,PC507,PC51
282074338003	TF041-TH-IC;74CBTD3384,10 BIT BU	U529
288227002044	TF041-TH-TRANS;AP2N7002K,N-CHANN	PQ1,PQ4,PQ505,PQ507,PQ6,Q3,Q
291000012207	TF041-TH-CON;HDR-SATA,H2.94MM,C1	J7
271061103307	TF041-TH-RES;10K ,1/16W,5% ,040	R395,R397,R583
342804400009	TF041-SMT NUT;M2.0,B40M20-301230	MTG503,MTG504,MTG505,MTG50
271061181105	TF041-TH-RES;180,1/16W,1%,0402,S	R131,R158,R159,R593,R594,R595,F
271071683102	TF041-TH-RES;68K ,1/16W,1% ,060	PR21,PR506,PR557
272421107515	TF041-TH-CAP;100U,6.3V,+/-20%,H1	C454,C477
271061105307	TF041-TH-RES;1M ,1/16W,5% ,040	R2,R23,R676,R816,R829
271071471103	TF041-TH-RES;470 ,1/16W,1% ,060	PR27,PR569
272102104708	TF041-TH-CAP;0.1U ,16V,+80-20%,	C102,C127,C128,C131,C136,C141,C
272430337501	TF041-TH-CAP;330uF,2V, 20%,15mo	C749
271061121120	TF041-TH-RES;121,1/16W,1%,0402,S	R2058
342808100001	TF041-SMT-NUT;A40M20-45AS-8824	MTG1

Part Number	Decription	Location(S)
271061490102	TF041-TH-RES;49.9 ,1/16W,1% ,040	R193,R194,R249,R250,R251,R252,F
271071390306	TF041-TH-RES;39 ,1/16W,5% ,060	R2027,R437
272001226518	TF041-TH-CAP;22U,10V,+ 20%,0805	C347,C489
272003107501	TF041-TH-EC;100U,25V,20%,D6.3,L8	PC582,PC583,PC584
274012700434	TF041-TH-XTAL;27MHZ,20PF,30PPM,8	X505
284501819006	TF041-TH-IC;P1819B,EMI REDUCTION	U532
271061223105	TF041-TH-RES;22K,1/16W,1% ,0402,	R812
271061750303	TF041-TH-RES;75 ,1/16W,5% ,040	R637
271071470103	TF041-TH-RES;4.32K,1/16W,1% ,060	PR547
272001106550	TF041-TH-CAP;10U,6.3V,+20%,0805	C103,C122,C125,C130,C134,C137,C
272001106549	TF041-TH-CAP;10U,10V,+20%,0805,	C541,C819
272011226509	TF041-TH-CAP;22U,6.3V,+20%,1206	PC74
272101104442	TF041-TH-CAP;0.1U,CR,10V,10%,040	C219,C220,C221,C222,C223,C224,C
272431337548	TF041-TH-CAP;330uF,2V, 20%,6m	PC47,PC548,PC549
284500007024	TF041-TH-BFM-BENQ-IC;ICH7M,SOUTH	U13
284500883002	TF041-TH-IC,ALC883-GR,AUDIO CODE	U525
284500945008	TF041-TH-BFM-BENQ-IC;945PM,NORTH	U512
286102030002	TF041-TH-IC;APA2030RI-T RL,AMPLIF	U524
288203415002	TF041-TH-TRANS;AO3415,P-MOSFET ,4	Q29
291000920610	TF041-TH-CON;STEREO JACK,6P,W9.5	J520,J521
291000615202	TF041-TH-CON;MINIPCI EXPRESS SOC	J516,J517
291000615001	TF041-TH-CON;BTB-SOCKET,FEMALE,5	J504
272101334702	TF041-TH-CAP;0.33U ,CR,10V ,+80-	C456
295000010247	TF041-TH-FUSE;FAST,7A/24V,1206,S	PF1
274011200427	TF041-TH-XTAL;12MHZ,16PF,30PPM,	X1

8224 N/B Maintenance

9. Spare Parts List - 8

Part Number	Decription	Location(S)
273000500309	TF041-TH-CHOKE COIL;90OHM/100MHZ	L504,L506,L507,L508,L511,L512,I
365350000004	SOLDER WIRE;LEAD_FREE,ECO,RMA98S	
297150200023	TF041-TH-SW;SLIDE SWITCH,NSS504-	SW4
339115000074	TF041-MICROPHONE;-62dB+-2dB,D6.0	MIC1
342804400003	TF041-SHIELDING;EXPRESS CARD,EXP	J5
242600000566	TF041-LABEL;BLANK,7MM*7MM,PRC	
242600000567	TF041-LABEL;32*7MM,POLYESTER FIL	
242600000564	TF041-LABEL;25*6,HI-TEMP,COMMON	
346804400001	TF041-INSULATOR;MB,8224	
346804400002	TF041-INSULATOR;NEW CARD,8224	
346804400008	TF041-INSULATOR;DDR,PCI,8224	
346804400006	TF041-INSULATOR;PCI,MODEM,8224	
346804400007	TF041-INSULATOR;HEAT SINK,MB,8224	
370102010509	TF041-SPC-SCREW;M2L5,K-HD(+1),NI	
345803700005	TF041-SPONGE;RTC BATTERY,8090	
422802800003	TF041-WIRE ASSY;BATT TO MB,MOLEX	
343803700001	TF041-HEAT SINK;NORTHBRIDGE,8090	
348208020020	TF041-GASKET;2,08,020,020	
348105040015	TF041-GASKET;1,05,040,015	
348206020006	TF041-GASKET;2,6,020,006	
348206035024	TF041-GASKET;2,06,035,024	
346804300013	TF041-INSULATOR;CHP,SABLE GT	
346804400026	TF041-INSULATOR;DDR,8224	
348208080025	TF041-GASKET;2,08,080,025	
345804400007	TF041-SPONGE;LENS,MB,8224	

Part Number	Decription	Location(S)
371102010263	TF041-SCREW;M2L2.5,K-HD(+1),D4.0	
346804400022	TF041-INSULATOR;CARDREADER,8224	
348203020050	TF041-GASKET;2,03,020,050	
442686800007	TF041-TOUCHPAD;TM61PDZG391	
340804400006	TF041-HEAT SINK ASSY;8224	
341800200007	TF041-SPRING-SCREW-HEAT SINK-LYNX	
370102610409	TF041-SPC-SCREW;M2.6L4,K-HD,T0.8	
411804400035	TF041-PWA;PWA-8224,DAUGHTER BD-B	
411804400037	TF041-PWA;PWA-8224,DAUGHTER BD,S	
271009103101	TF041-TH-RES;10K ,1/10W,1% ,080	BPR21,BPR25
271045107104	TF041-TH-RES;01 ,1W ,1% ,2512	BPR27
271061000003	TF041-TH-RES;0 ,1/16W,0402,SM	BR504
271061102113	TF041-TH-RES;1K ,1/16W,1% ,040	BR1,BR501
271061104108	TF041-TH-RES;100K ,1/16W,1% ,040	BPR2
271061105307	TF041-TH-RES;1M ,1/16W,5% ,040	BPR22
271061221318	TF041-TH-RES;220 ,1/16W, 5% ,040	BR505,BR506
271061333304	TF041-TH-RES;33K ,1/16W,5% ,0402	BR4,BR503,BR6
271061473502	TF041-TH-RES;47K ,1/16W,5% ,040	BR3,BR5,BR502
271061474304	TF041-TH-RES;470K ,1/16W,5% ,040	BR2
271071000312	TF041-TH-RES;0 ,1/16W,5% ,060	BL501,BL503,BL504,BL506,BL507
271071100103	TF041-TH-RES;10 ,1/16W,1% ,060	BPR26,BPR29
271071102107	TF041-TH-RES;1K ,1/16W,1% ,060	BPR18
271071104108	TF041-TH-RES;100K ,1/16W,1% ,060	BPR28
271071112106	TF041-TH-RES;1.13K,1/16W,1%,0603	BPR17
271071228306	TF041-TH-RES;2.2 ,1/16W,5% ,060	BPR3,BPR4,BPR5

8224 N/B Maintenance

9. Spare Parts List - 9

Part Number	Decription	Location(S)
271071394305	TF041-TH-RES;390K ,1/16W,5% ,060	BPR16
271071471103	TF041-TH-RES;470 ,1/16W,1% ,060	BPR15
271071751104	TF041-TH-RES;750 ,1/16W,1% ,060	BPR7,BPR8
271072300331	TF041-TH-RES;300K ,1/10W,5% ,060	BPR10
271079474101	TF041-TH-RES;470K,1/10W,1% ,0603	BPR501
272000226501	TF041-TH-CAP;22U ,CR,6.3V,0805,X	BC4,BC505,BC9
272001105410	TF041-TH-CAP;1U ,10%,10V ,0805	BPC43
272005104410	TF041-TH-CAP;0.1U ,50V,+/-10%,08	BPC13,BPC27
272013106504	TF041-TH-CAP;10U,25V,+/-20%,1206	BPC30,BPC32,BPC33,BPC41
272071105411	TF041-TH-CAP;1U ,10V ,10%,0603,X	BPC17,BPC24
272071475403	TF041-TH-CAP;4.7U,6.3V,10%,0603,	BPC4,BPC8
272072105403	TF041-TH-CAP;0.1U ,CR,16V,10%,0	BC5,BC504,BC8,BPC19,BPC3,BPC7
272072224405	TF041-TH-CAP;0.22U ,16V ,10%,060	BPC22
272073104713	TF041-TH-CAP;0.1U ,25V,+80-20%,	BPC21,BPC5,BPC6
272075102419	TF041-TH-CAP;1000P,CR,50V,10%,06	BPC37
272075103414	TF041-TH-CAP;0.01U ,CR,50V ,10%,	BPC42,BPC44,BPC45
272075104710	TF041-TH-CAP;0.1U ,50V,+80-20%,	BPC12,BPC16,BPC36,BPC40,BPC4
272075271408	TF041-TH-CAP;270P ,50V,+10%,060	BPC26,BPC34
272102104708	TF041-TH-CAP;0.1U ,16V,+80-20%,	BC1,BC501
272105102421	TF041-TH-CAP;1000P,CR,50V,10%,04	BC2,BC503,BC7,BPC11,BPC15,BPC
272431157520	TF041-TH-CAP;150U,KOCAP,6.3V,20%	BPC1,BPC10,BPC2,BPC9
273000610037	TF041-TH,FERRITE CHIP;120OHM/100	BPL1,BPL2,BPL5,BPL6
273000610041	TF041-TH,FERRITE CHIP;120OHM/100	BL1,BL2,BL510,BPL7,BPL8
273000990430	TF041-TH-INDUCTOR;6.8uH,4.8A,27m	BPL4
286104173002	TF041-TH-IC;MAX4173F,I-SENSE AMP	BPU2

Part Number	Decription	Location(S)
286306232002	TF041-TH-IC;ISL6232,PWM ,QSOP,28	BPU1
286309701004	TF041-TH-IC;RT9701PB,POWER DISTR	BU1,BU2,BU501
288100024013	TF041-TH-DIODE;RLZ24B,ZENER,SOD-	BPD7
288100701003	TF041-TH-DIODE;BAV70LT1,70V,225M	BPD501,BPD502
288101040012	TF041-TH-DIODE;PDS1040,10A SCHOT	BPD5
288105543002	TF041-TH-DIODE;BZV55-C4V3,ZENER,	BPD1
288105556002	TF041-TH-DIODE;BZV55-C5V6,ZENER,	BPD3
288204407002	TF041-TH-TRANS;AO4407,P-MOS,01O	BPQ5
288204702004	TF041-TH-TRANS;AO4702, N-MOSFET,	BPQ1,BPQ3
288209003005	TF041-TH-TRANS;RSS090N03,N-MOSFE	BPQ2,BPQ4
288227002044	TF041-TH-TRANS;AP2N7002K,N-CHANN	BPQ6
291000010440	TF041-TH-CON;HDR,MA,4P,1.25MM,H3	BJ503
294011200538	TF041-TH-LED;BLUE/ORG,19-22UYOSU	BD503
295000010205	TF041-TH-FUSE;NORMAL,5A/24VDC,32	BPF1
295000010243	TF041-TH-FUSE;NANO,10A/125V,R451	BPF2
297040100039	TF041-TH-SW;PUSH BUTTOM,5P,SPST,	BSW501
331000008100	TF041-TH-CON;USB,FM,H15.64,R/A,4	BJ504
331040004042	TF041-TH-CON;HDR,MA,4P*1,R/A,USB	BJ502
316804400002	TF041-TH-PCB;PWA-8224/Daughter A	R02
297140200007	TF041-TH-SW;COVER SWITCH,SPST,30	BSW502
331910002016	TF041-TH-CON;DC POWER JACK,2P,20	BPJ501
242600000632	TF041-LABEL;27*7MM,XF-5811;POLYI	
242600000562	TF041-LABEL;6*6MM,GAL,BLANK,COMM	
242600000566	TF041-LABEL;BLANK,7MM*7MM,PRC	
361200003064	TF041-SOLDER PASTE;SN96.5/AG3.0/	

8224 N/B Maintenance

9. Spare Parts List - 10

Part Number	Decription	Location(S)
361200001024	TF041-CLEANNER;YC-336,LIQUID,STE	
271071333102	TF041-TH-RES;33K ,1/16W,1% ,060	BPR11
271071103117	TF041-TH-RES;10.2K,1/16W,1%,0603	BPR12
291000010052	TF041-TH-CON;BOX HEADER,T03@112-	BJ501
273000501293	TF041-TH-CHOKE COIL;4.7UH,+/-30%	BPL3
422804400010	TF041-WIRE ASSY;MMCX R/A JACK WI	
346804400003	TF041-INSULATOR;DB,8224	
345804400008	TF041-SPONGE;DB,8224	
348110010010	TF041-GASKET;1,10,010,010	
348205050005	TF041-GASKET;2,05,050,005	
348210015010	TF041-GASKET;2,10,015,010	
412803400005	TF041-PCB ASSY;FAX MODEM 56K,145	
441804400001	TF041-BATT ASSY;LI-ION,10.8V/4.7	
222687630001	TF041-PE BUBBLE BAG;BATTERY,GRAM	
225686920001	TF041-TAPE;INSULATING,POLYESTER	
225686920002	TF041-TAPE;ADHENSIVE,DOUBLE-FACE	
226687620001	TF041-SPONGE;320*290*10,CAIMAN,P	
242683200024	TF041-LABEL;5*20,BLANK,COMMON	
242686000009	TF041-LABEL;LOT NUMBER,HOOK	
242687600004	TF041-LABEL;MIRRIR PAPER,WHITE,E	
242804400001	TF041-LABEL;BATT,10.8V/4.7Ah,LI,	
333020000025	TF041-SHRINK TUBE;300V,125,I.D=2	
333025000015	TF041-SHRINK TUBE;300V,125,I.D=2	
338936020006	TF041-BATTERY;LI,3.6V/2.35AH,CGR	
342686000018	TF041-TH-CONTACT PLATE;W5L63T0.1	

Part Number	Decription	Location(S)
342686900015	TF041-CONTACT PLATE;W5L63T0.13mm	
342686900017	TF041-CONTACT PLATE;T=0.13mm,L=8	
342801200002	TF041-CONTACT PLATE;W5L27T0.13,T	
346686900016	TF041-INSULATOR;BATT ASSY,BATT+,	
346686900017	TF041-INSULATOR;FIBER,T=0.25mm,1	
346686900019	TF041-INSULATOR;FIBRE,T=1.2mm,L=	
346686900020	TF041-INSULATOR;FIBER,T=0.25,2CE	
361200003064	TF041-SOLDER PASTE;SN96.5/AG3.0/	
361400004013	TF041-ADHESIVE;ABS+PC PACK,G485,	
411804400001	TF041-PWA;PWA-8224/BATT,LI,PANAS	
310111103041	TF041-THERMISTOR;10K,1%,RA,DISK,	RT1
331000007063	TF041-CONNECTOR;7 PIN,DIP,ALLTOP	CON1
333020000026	TF041-SHRINK TUBE;UL,600V,105°C,	
335152000127	TF041-TH-FUSE;LR4-73X,POLY SWITC	
335152000128	TF041-FUSE; 128 DC-7A/50V 139 ,	F2
361400003017	TF041-JET-MELT ADHESIVES;3478-Q,	
365350000009	LF-SOLDER WIRE;SN96.5/AG3.0/CU0.	
332100026014	TF041-WIRE;#26,UL1007,93MM, YELLO	CN2
332110026167	TF041-WIRE;#26,UL1007,40MM,ORANG	CN3
335152000134	TF041-FUSE;THERMAL FUSE,G7F510,9	
332100020031	TF041-WIRE;#20,UL1007,117mm,BLAC	CN5
411803700013	TF041-PWA;PWA-8090/BATT,PANASONI	
271045059102	TF041-TH-RES;0.050,1W, 1%,2512,S	R24,R24A,R24C
271048107101	TF041-TH-RES;0.010,2W,1%,2512,SM	R6
271071000312	TF041-TH-RES;0 ,1/16W,5% ,060	C16,R31

8224 N/B Maintenance

9. Spare Parts List - 11

Part Number	Decription	Location(S)
271071101309	TF041-TH-RES;100 ,1/16W,5% ,060	R11,R12,R14,R15,R16,R20,R21
271071103310	TF041-TH-RES;10K ,1/16W,5% ,060	R5,R7,R8
271071104108	TF041-TH-RES;100K ,1/16W,1% ,060	R18,R22,R23,R9
271071105312	TF041-TH-RES;1M ,1/16W,5% ,060	R10,R3
271071201306	TF041-TH-RES;200 ,1/16W,5% ,060	R1A,R1B
271071204104	TF041-TH-RES;200K ,1/16W,1% ,060	R17B
271071224305	TF041-TH-RES;220K ,1/16W,5% ,060	R1
271071331306	TF041-TH-RES;330 ,1/16W,5% ,060	C14
271071494101	TF041-TH-RES;499K ,1/16W,1% ,060	R17A
272005105702	TF041-TH-CAP ;1U CR 50V +80-20%	C14A,C14B,C4A,C4B
272075010401	TF041-TH-CAP; 0.001U CR 50V 10%	C13
272075102424	TF041-TH-CAP ;0.1U CR 50V 10% 06	C10,C11,C12,C15,C3,C5,C6,C7,C8,C
272075221701	TF041-TH-CAP; .22u,50v,+80-20%,06	C1,C2,C20A,C24,C25
272075470407	TF041-TH-CAP; 0.0047U CR 50V 10%	C4
283240260001	TF041-TH-IC;EEPROM,M24C02-WMN6T,	IC2
286002040002	TF041-TH-IC;BQ2040,GAS GAUGE,SO,	IC1
286301414005	TF041-TH-IC;MM1414,PROTECTION,T,S	IC4
286400812001	TF041-TH-IC;S-812C,DECECTOR,SOT-	IC3
288100056032	TF041-TH-DIODE;PDZ5.6B,ZENER,5.6	ZD3,ZD4
288100717001	TF041-TH-DIODE;SDMG0340LA,SCHOTT	D3
288101355004	TF041-TH-DIODE;1N4448HWS-F,80V,1	D2
288111544002	TF041-TH-DIODE;SIG-F,400V,1.0A,S	D1
288200144035	TF041-TH-TRANS;DDT A144EKA,PNP,SM	Q1
288204409003	TF041-TH-TRANS;AO4409,P-MOSFET,S	Q3,Q5
316686900004	TF041-PCB;PWA-8965-8066/BATTERY	R0B

Part Number	Decription	Location(S)
361200003064	TF041-SOLDER PASTE;SN96.5/AG3.0/	
242804400010	TF041-TH-LABEL;BAR CODE,20*5,BLA	
225680620003	TF041-TAPE;ADHESIVE,DOUBLE-FACE,	
344804400025	TF041-COVER;BATTERY,8224	
344804400026	TF041-HOUSING;BATTERY,8224	
346686900030	TF041-INSULATOR;FIBRE,W12L125,SI	
342680800002	TF041-CONTACT PLATE;W4L12T0.15,G	
442685200004	TF041-AC ADPT ASSY;19V,4.74A,DEL	
242803400065	TF041-LABEL;SCREW ,HDD COVER,BEN	
242803400066	TF041-LABEL;BEN Q,SPEC.,170mm*70	
242803400067	TF041-LABEL;BEN Q,BAR CODE,100mm	
242804400048	TF041-LABEL;AK CONTECT ,BEN Q,822	
242804400029	TF041-LABEL;RATING,BENQ,90W,8224	
242804400030	TF041-LABEL;INNER CARTON,BENQ,82	
242600000559	TF041-LABEL;BAR CODE,125*65,COMM	
242679900009	TF041-LABEL;BAR CODE,(25*10MM)*1	
242300400022	TF041-LABEL;BLANK,60*80MM,LL-261	
242803400070	TF041-LABEL;50mmx10mm,BEN Q,8050	
242804400003	TF041-NAMEPLATE;LCD COVER,BEN Q,	
242803400064	TF041-LABEL;SEAL,CARTON,BEN Q,80	
242804400004	TF041-NAMEPLATE;LCD HOUSING,BEN	
242804400052	TF041-LABEL;BARCODE,70x20,BEN Q,	
242804400015	TF041-NAMEPLATE;KB COVER,JOYBOOK	
242687800047	CFM-ATI;LABEL,ATI,9110089100,16.	
531080440002	TF041-KBD;TRADITIONAL CHINESE,DA	

ITEM	PART NO	DESCRIPTION	QTY	TYPE	REMARK
1	340804400007	TF041-COVER ASSY;LCD,8224	1	ASSEMBLY	
2	340804400008	TF041-HOUSING ASSY;LCD,8224	1	ASSEMBLY	
3	340804400009	TF041-SPEAKER ASSY;8224	1	ASSEMBLY	
4	342804400006	TF041-HINGE;R,SINHER,8224	1	ASSEMBLY	
5	342804400007	TF041-HINGE;L,SINHER,8224	1	ASSEMBLY	
6	346804400011	TF041-INSULATOR;INVERTER,8224	1	PART	
7	346804400014	TF041-RUBBER;LCD COVER,8224	2	PART	
8	370102030304	TF041-SPC-SCREW; M2L3,K-HD,ZnB/N	6	PART	
9	370102610409	TF041-SPC-SCREW;M2.6L4,NiW,K-HD,	6	PART	
10	370102610604	TF041-SPC-SCREW;M2.6L6,K-HDK+DD	2	PART	
11	371102010263	TF041-SCREW;M2L2.5,K-HEAD(+),NI	10	PART	
12	412804400001	TF041-PCB ASSY;D/A BD,8224	1	ASSEMBLY	
13	413000020686	TF041-TFT LCD;B141EVO1V.1,14.1	1	PART	
14	422804400003	TF041-WIRE ASSY;LCD,8224	1	ASSEMBLY	
15	422804400004	TF041-WIRE ASSY;INVERTER,8224	1	ASSEMBLY	
16	422804400007	TF041-WLAN ASSY;LCD HOUSING,8224	1	ASSEMBLY	

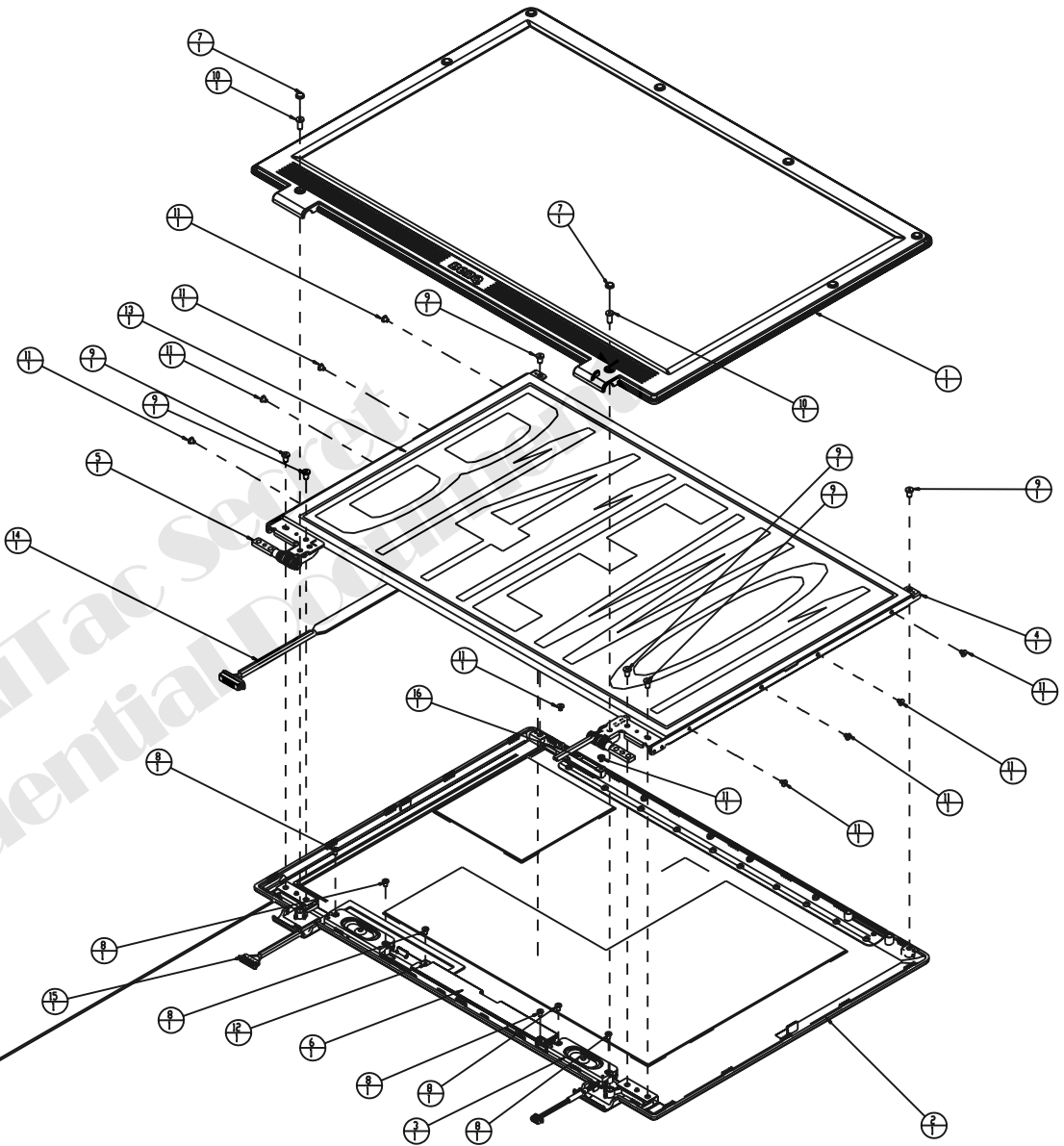

DATE	10-10-05	MATERIAL	SEE NOTES	TREATMENT	REMARK
DRAWN	DESIGNED	CHECKED	APPROVED	MATERIAL NO.	MF 451804400005 R10A
MITAC Technology Corp.					

Model name: LCD-ASSY-8224

File name: LCD-ASSY-8224

SHEET NO. 1 of 1

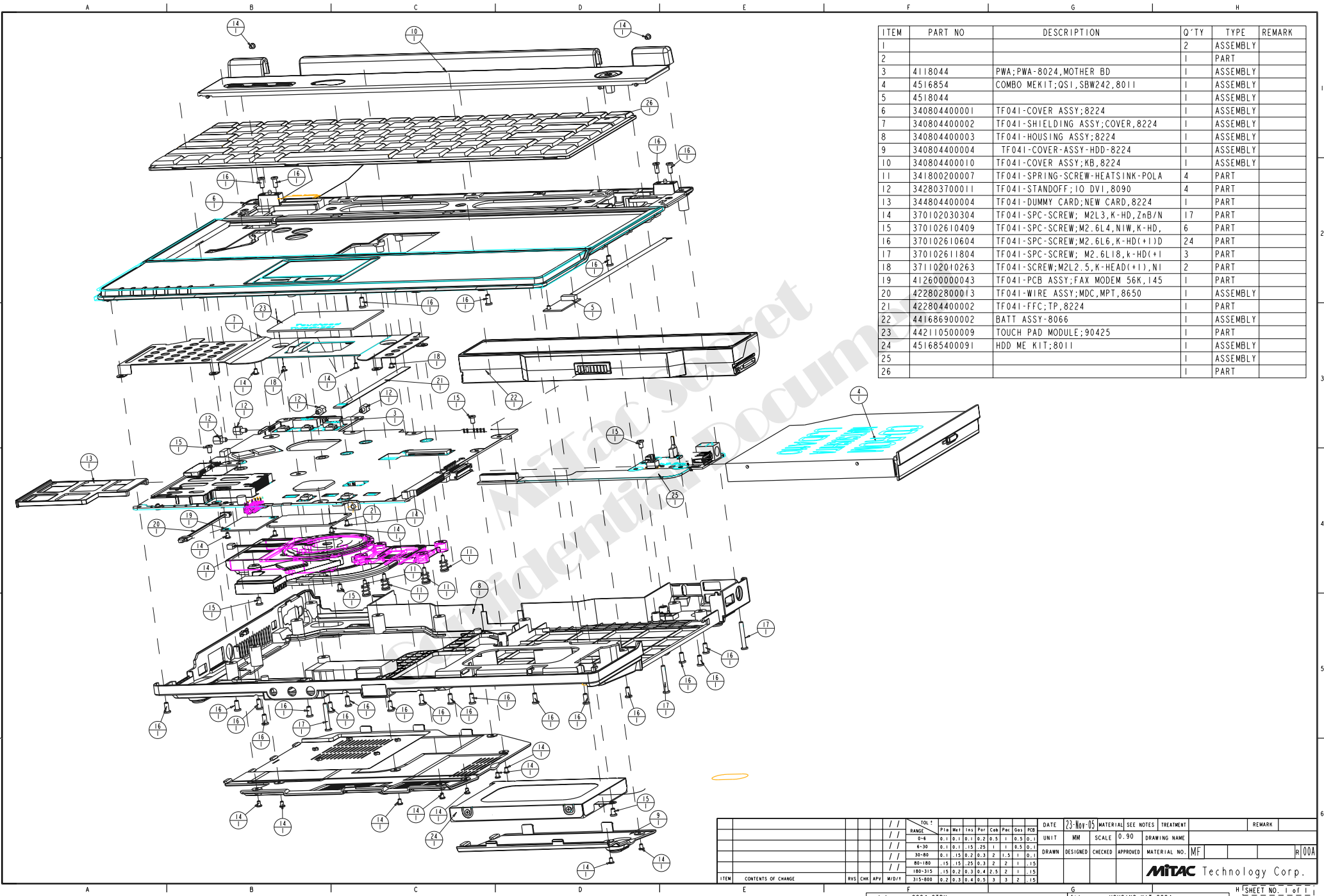

ITEM	PART NO	DESCRIPTION	Q'TY	TYPE	REMARK
1			2	ASSEMBLY	
2			1	PART	
3	4118044	PWA;PWA-8024,MOTHER BD	1	ASSEMBLY	
4	4516854	COMBO MEKIT;OS1,SBW242,8011	1	ASSEMBLY	
5	4518044		1	ASSEMBLY	
6	340804400001	TF041-COVER ASSY;8224	1	ASSEMBLY	
7	340804400002	TF041-SHIELDING ASSY;COVER,8224	1	ASSEMBLY	
8	340804400003	TF041-HOUSING ASSY;8224	1	ASSEMBLY	
9	340804400004	TF041-COVER-ASSY-HDD-8224	1	ASSEMBLY	
10	340804400010	TF041-COVER ASSY;KB,8224	1	ASSEMBLY	
11	341800200007	TF041-SPRING-SCREW-HEATSINK-POLA	4	PART	
12	342803700011	TF041-STANDOFF; IO DVI,8090	4	PART	
13	344804400004	TF041-DUMMY CARD;NEW CARD,8224	1	PART	
14	370102030304	TF041-SPC-SCREW; M2L3,K-HD,ZnB/N	17	PART	
15	370102610409	TF041-SPC-SCREW;M2.6L4,N1W,K-HD,	6	PART	
16	370102610604	TF041-SPC-SCREW;M2.6L6,K-HD(+1)D	24	PART	
17	370102611804	TF041-SPC-SCREW; M2.6L18,k-HD(+1)	3	PART	
18	371102010263	TF041-SCREW;M2L2.5,K-HEAD(+1),NI	2	PART	
19	412600000043	TF041-PCB ASSY;FAX MODEM 56K,145	1	PART	
20	422802800013	TF041-WIRE ASSY;MDC,MPT,8650	1	ASSEMBLY	
21	422804400002	TF041-FFC;TP,8224	1	PART	
22	441666900002	BATT ASSY-8066	1	ASSEMBLY	
23	442110500009	TOUCH PAD MODULE;90425	1	PART	
24	451685400091	HDD ME KIT;8011	1	ASSEMBLY	
25			1	ASSEMBLY	
26			1	PART	

TOL 2												DATE	23-Nov-05	MATERIAL	SEE NOTES	TREATMENT	REMARK				
RANGE												UNIT	MM	SCALE	0.90	DRAWING NAME					
0-4	0.1	0.1	0.2	0.5	1	0.5	0.1					DRAWN	DESIGNED	CHECKED	APPROVED	MATERIAL NO.	MF			R00A	
4-30	0.1	0.1	.15	.25	1	1	0.5	0.1													
30-80	0.1	0.15	0.2	0.3	2	1.5	1	0.1													
80-180	.15	.15	.25	.3	2	2	1	.15													
180-315	.15	0.2	0.3	0.4	2.5	2	1	.15													
315-600	0.2	0.3	0.4	0.5	3	3	2	.15													

MITAC Technology Corp.

Reference Material

- ❖ Intel Yonah/Merom Processor Intel.INC
- ❖ Intel 945GM/945PM North Bridge Intel.INC
- ❖ Intel ICH7-M South Bridge Intel.INC
- ❖ Clock Generator ICS9LR310 ICS.INC
- ❖ Keyboard Controller W83L951DG Data Sheet WIN.INC
- ❖ System Explode View Technology.Corp./MiTAC
- ❖ 8224 Hardware Engineering Specification Technology.Corp./MiTAC

SERVICE MANUAL FOR 8224

Sponsoring Editor: Ally Yuan

Author: Star Meng

Publisher: MiTAC International Corp.

Address: No.269, Road 2, Export Processing Zone, Kunshan, P.R.C

Tel: 086-512-57367777

Fax: 086-512-57385099

First Edition: Mar. 2006

E-mail: Ally.Yuan @ mic.com.tw

Web: <http://www.mitac.com>

<http://www.mtc.mitacservic.com>
