



# Low-Cost, 230MHz, Single/Quad Op Amps with Rail-to-Rail Outputs and $\pm 15\text{kV}$ ESD Protection

## General Description

The MAX4385E/MAX4386E op amps are unity-gain stable devices that combine high-speed performance, rail-to-rail outputs, and  $\pm 15\text{kV}$  ESD protection. Targeted for applications where an input or an output is exposed to the outside world, such as video and communications, these devices are compliant with International ESD Standards:  $\pm 15\text{kV}$  IEC 1000-4-2 Air-Gap Discharge,  $\pm 8\text{kV}$  IEC 1000-4-2 Contact Discharge, and the  $\pm 15\text{kV}$  Human Body Model.

The MAX4385E/MAX4386E operate from a single 5V supply with a common-mode input voltage range that extends beyond  $V_{EE}$ . The MAX4385E/MAX4386E consume only 5.5mA of quiescent supply current per amplifier while achieving a 230MHz -3dB bandwidth, 30MHz 0.1dB gain flatness and a 450V/ $\mu\text{s}$  slew rate.

## Applications

Set-Top Boxes	CCD Imaging Systems
Surveillance Video Systems	Video Routing and Switching Systems
Battery-Powered Instruments	Digital Cameras
Analog-to-Digital Converter Interface	Video-on-Demand
	Video Line Driver

## Typical Operating Circuit

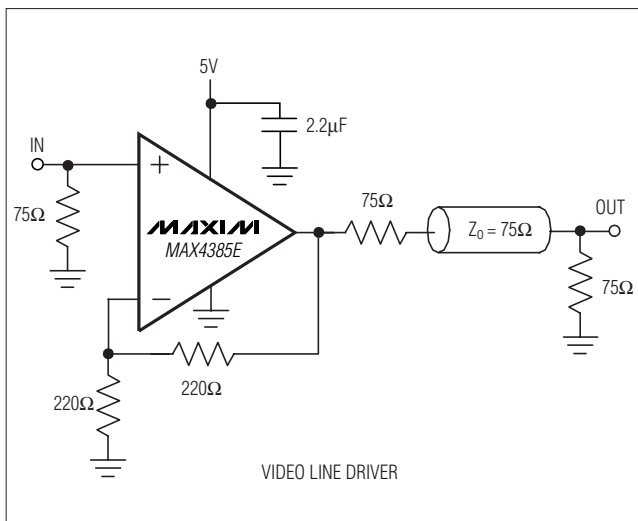

## Features

- ◆ ESD-Protected Inputs and Outputs
  - $\pm 15\text{kV}$ —Human Body Model
  - $\pm 8\text{kV}$ —IEC 1000-4-2 Contact Discharge
  - $\pm 15\text{kV}$ —IEC 1000-4-2 Air-Gap Discharge
- ◆ Low Cost and High Speed
  - 230MHz -3dB Bandwidth
  - 30MHz 0.1dB Gain Flatness
  - 450V/ $\mu\text{s}$  Slew Rate
- ◆ Rail-to-Rail Outputs
- ◆ Input Common-Mode Range Extends Beyond  $V_{EE}$
- ◆ Low Differential Gain/Phase: 0.02%/0.01°
- ◆ Low Distortion at 5MHz
  - 60dBc SFDR
  - 58dB Total Harmonic Distortion
- ◆ Ultra-Small 5-Pin SOT23 and 14-Pin TSSOP Packages

## Ordering Information

PART	TEMP RANGE	PIN-PACKAGE	TOP MARK
MAX4385EEUK-T	-40°C to +85°C	5 SOT23-5	ADZL
MAX4386EESD	-40°C to +85°C	14 SO	—
MAX4386EEUD	-40°C to +85°C	14 TSSOP	—

## Pin Configurations

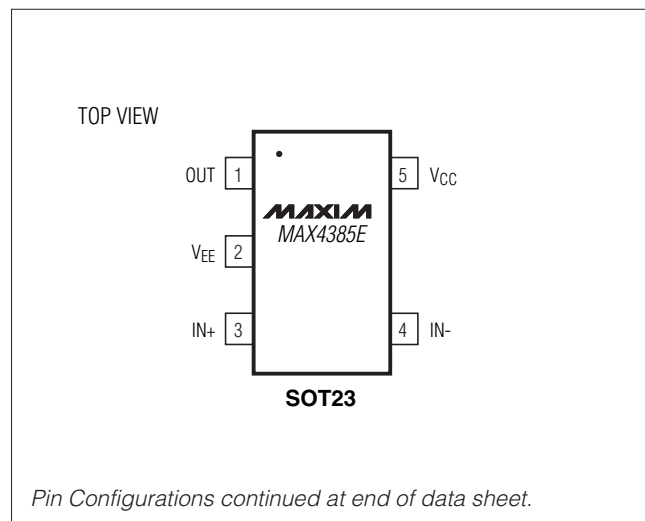

# Low-Cost, 230MHz, Single/Quad Op Amps with Rail-to-Rail Outputs and $\pm 15\text{kV}$ ESD Protection

## ABSOLUTE MAXIMUM RATINGS

Power-Supply Voltage ( $V_{CC}$ to $V_{EE}$ ).....	-0.3V to +6V	14-Pin SO (derate 8.33mW/°C above +70°C).....	667mW
$IN_+$ , $IN_-$ , $OUT_+$ .....	( $V_{EE} - 0.3\text{V}$ ) to ( $V_{CC} + 0.3\text{V}$ )	14-Pin TSSOP (derate 10mW/°C above +70°C).....	727mW
Output Short-Circuit Duration to $V_{CC}$ or $V_{EE}$ .....	Continuous	Operating Temperature Range .....	-40°C to +85°C
Continuous Power Dissipation ( $T_A = +70^\circ\text{C}$ )		Junction Temperature .....	+150°C
5-Pin SOT23 (derate 8.7mW/°C above +70°C).....	696mW	Storage Temperature Range .....	-65°C to +150°C
		Lead Temperature (soldering, 10s).....	+300°C

Stresses beyond those listed under "Absolute Maximum Ratings" may cause permanent damage to the device. These are stress ratings only, and functional operation of the device at these or at any other conditions beyond those indicated in the operational sections of the specifications is not implied. Exposure to absolute maximum rating conditions for extended periods may affect device reliability.

## DC ELECTRICAL CHARACTERISTICS

( $V_{CC} = 5\text{V}$ ,  $V_{EE} = 0$ ,  $V_{CM} = V_{CC}/2$ ,  $V_{OUT} = V_{CC}/2$ ,  $R_L = \infty$  to  $V_{CC}/2$ ,  $C_{BYPASS} = 2.2\mu\text{F}$ ,  $T_A = T_{MIN}$  to  $T_{MAX}$ , unless otherwise noted. Typical values are at  $T_A = +25^\circ\text{C}$ .) (Note 1)

PARAMETER	SYMBOL	CONDITIONS	MIN	TYP	MAX	UNITS
Input Common-Mode Voltage Range	$V_{CM}$	Guaranteed by CMRR	$V_{EE} - 0.2$		$V_{CC} - 2.25$	V
Input Offset Voltage	$V_{OS}$	$T_A = +25^\circ\text{C}$		0.2	20	mV
		$T_A = -40^\circ\text{C}$ to $+85^\circ\text{C}$			28	
Input Offset Voltage Matching		MAX4386E		1		mV
Input Offset Voltage Tempco	$TC_{VOS}$			8		$\mu\text{V}/^\circ\text{C}$
Input Bias Current	$I_B$			6.5	20	$\mu\text{A}$
Input Offset Current	$I_{OS}$			0.5	7	$\mu\text{A}$
Input Resistance	$R_{IN}$	Differential mode ( $-1\text{V} \leq V_{IN} \leq +1\text{V}$ )		70		$\text{k}\Omega$
		Common mode ( $-0.2\text{V} \leq V_{CM} \leq +2.75\text{V}$ )		3		$\text{M}\Omega$
Common-Mode Rejection Ratio	CMRR	$V_{EE} - 0.2\text{V} \leq V_{CM} \leq V_{CC} - 2.25\text{V}$	70	95		dB
Open-Loop Gain	$A_{VOL}$	$0.25\text{V} \leq V_{OUT} \leq 4.75\text{V}$ , $R_L = 2\text{k}\Omega$	50	61		dB
		$0.8\text{V} \leq V_{OUT} \leq 4.5\text{V}$ , $R_L = 150\Omega$	48	63		
		$1\text{V} \leq V_{OUT} \leq 4\text{V}$ , $R_L = 50\Omega$		58		
Output Voltage Swing	$V_{OUT}$	$R_L = 2\text{k}\Omega$	$V_{CC} - V_{OH}$	0.05	0.270	V
			$V_{OL} - V_{EE}$	0.05	0.150	
		$R_L = 150\Omega$	$V_{CC} - V_{OH}$	0.3	0.5	
			$V_{OL} - V_{EE}$	0.25	0.8	
		$R_L = 75\Omega$	$V_{CC} - V_{OH}$	0.5	0.8	
			$V_{OL} - V_{EE}$	0.5	1.75	
$R_L = 75\Omega$ to ground	$V_{CC} - V_{OH}$	1	1.7			
	$V_{OL} - V_{EE}$	0.025	0.125			
Output Current	$I_{OUT}$	Sinking from $R_L = 50\Omega$ to $V_{CC}$	40	55		mA
		Sourcing into $R_L = 50\Omega$ to $V_{EE}$	25	50		
Output Short-Circuit Current	$I_{SC}$	Sinking or sourcing		$\pm 100$		mA
Open-Loop Output Resistance	$R_{OUT}$			8		$\Omega$
Power-Supply Rejection Ratio	PSRR	$V_S = 4.5\text{V}$ to $5.5\text{V}$	50	62		dB

# Low-Cost, 230MHz, Single/Quad Op Amps with Rail-to-Rail Outputs and ±15kV ESD Protection

MAX4385E/MAX4386E

## DC ELECTRICAL CHARACTERISTICS (continued)

( $V_{CC} = 5V$ ,  $V_{EE} = 0$ ,  $V_{CM} = V_{CC}/2$ ,  $V_{OUT} = V_{CC}/2$ ,  $R_L = \infty$  to  $V_{CC}/2$ ,  $C_{BYPASS} = 2.2\mu F$ ,  $T_A = T_{MIN}$  to  $T_{MAX}$ , unless otherwise noted. Typical values are at  $T_A = +25^\circ C$ .) (Note 1)

PARAMETER	SYMBOL	CONDITIONS	MIN	TYP	MAX	UNITS
Operating Supply Voltage Range	$V_S$	Guaranteed by PSRR	4.5		5.5	V
Quiescent Supply Current (per Amplifier)	$I_S$			5.5	9	mA
ESD Protection Voltage (Note 2)		Human Body Model		±15		kV
		IEC 1000-4-2 Contact Discharge		±8		
		IEC 1000-4-2 Air-Gap Discharge		±15		

## AC ELECTRICAL CHARACTERISTICS

( $V_{CC} = 5V$ ,  $V_{EE} = 0$ ,  $V_{CM} = 1.5V$ ,  $R_L = 100\Omega$  to  $V_{CC}/2$ ,  $V_{OUT} = V_{CC}/2$ ,  $A_{VCL} = 1V/V$ ,  $T_A = +25^\circ C$ , unless otherwise noted.)

PARAMETER	SYMBOL	CONDITIONS	MIN	TYP	MAX	UNITS
Small-Signal -3dB Bandwidth	$BW_{SS}$	$V_{OUT} = 100mV_{P-P}$		230		MHz
Large-Signal -3dB Bandwidth	$BW_{LS}$	$V_{OUT} = 2V_{P-P}$		180		MHz
Small-Signal 0.1dB Gain Flatness	$BW_{0.1dBSS}$	$V_{OUT} = 100mV_{P-P}$		33		MHz
Large-Signal 0.1dB Gain Flatness	$BW_{0.1dBLS}$	$V_{OUT} = 2V_{P-P}$		30		MHz
Slew Rate	SR	$V_{OUT} = 2V$ step		450		V/ $\mu s$
Settling Time to 0.1%	$t_S$	$V_{OUT} = 2V$ step		14		ns
Rise/Fall Time	$t_R, t_F$	$V_{OUT} = 100mV_{P-P}$		4		ns
Spurious-Free Dynamic Range	SFDR	$f_C = 5MHz$ , $V_{OUT} = 2V_{P-P}$		-60		dBc
Harmonic Distortion	HD	$f_C = 5MHz$ , $V_{OUT} = 2V_{P-P}$	2nd harmonic	-70		dBc
			3rd harmonic	-60		
			total harmonic	-58		
Two-Tone, Third-Order Intermodulation Distortion	IP3	$f_1 = 4.7MHz$ , $f_2 = 4.8MHz$ , $V_{OUT} = 1V_{P-P}$		-60		dBc
Channel-to-Channel Isolation	$CH_{ISO}$	Specified at DC		-95		dB
Input 1dB Compression Point		$f_C = 10MHz$ , $A_{VCL} = 2V/V$		13		dBm
Differential Phase Error	DP	NTSC, $R_L = 150\Omega$		0.01		Degrees
Differential Gain Error	DG	NTSC, $R_L = 150\Omega$		0.02		%
Input Noise-Voltage Density	$e_n$	$f = 10kHz$		11.5		nV/ $\sqrt{Hz}$
Input Noise-Current Density	$i_n$	$f = 10kHz$		2		pA/ $\sqrt{Hz}$
Input Capacitance	$C_{IN}$			8		pF
Output Impedance	$Z_{OUT}$	$f = 10MHz$		2.2		$\Omega$

**Note 1:** All devices are 100% production tested at  $T_A = +25^\circ C$ . Specifications over temperature limits are guaranteed by design.

**Note 2:** ESD protection is specified for test point A and test point B only (Figure 6).

# Low-Cost, 230MHz, Single/Quad Op Amps with Rail-to-Rail Outputs and $\pm 15\text{kV}$ ESD Protection

## Typical Operating Characteristics

( $V_{CC} = 5\text{V}$ ,  $V_{EE} = 0$ ,  $V_{CM} = 1.5\text{V}$ ,  $A_{VCL} = 1\text{V/V}$ ,  $R_L = 100\Omega$  to  $V_{CC}/2$ ,  $T_A = +25^\circ\text{C}$ , unless otherwise noted.)

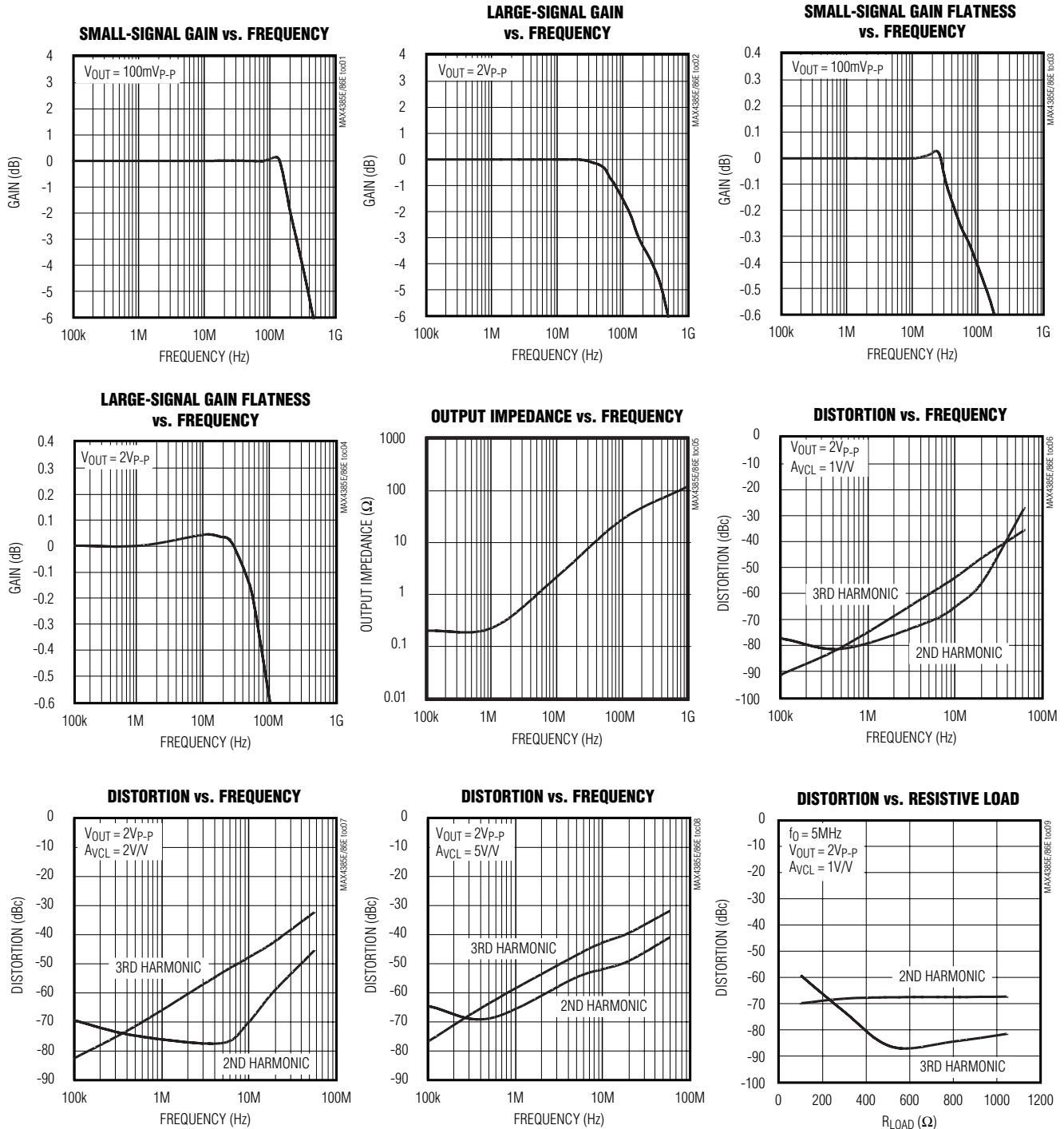

# Low-Cost, 230MHz, Single/Quad Op Amps with Rail-to-Rail Outputs and $\pm 15kV$ ESD Protection

## Typical Operating Characteristics (continued)

( $V_{CC} = 5V$ ,  $V_{EE} = 0$ ,  $V_{CM} = 1.5V$ ,  $A_{VCL} = 1V/V$ ,  $R_L = 100\Omega$  to  $V_{CC}/2$ ,  $T_A = +25^\circ C$ , unless otherwise noted.)

MAX4385E/MAX4386E

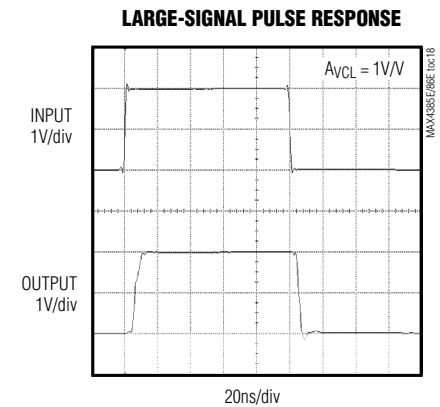
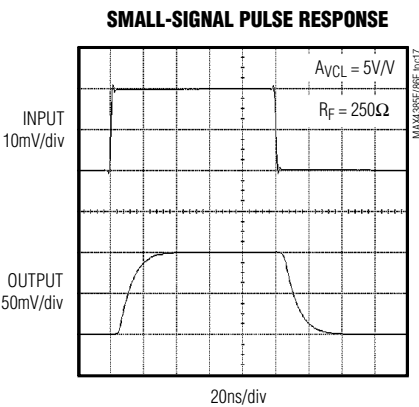
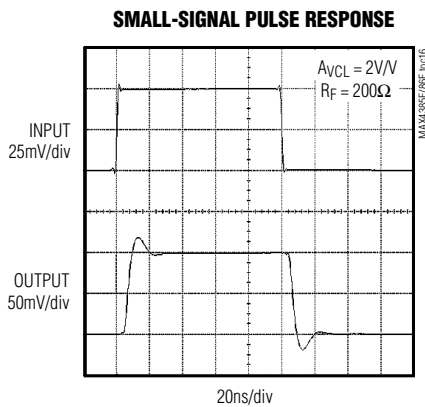
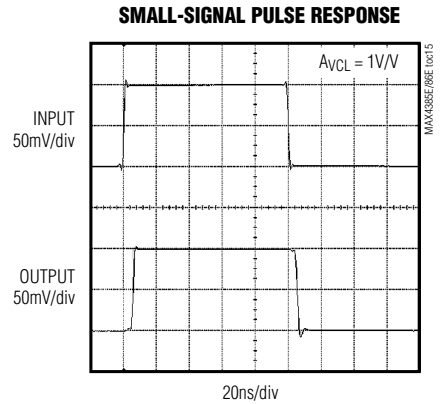
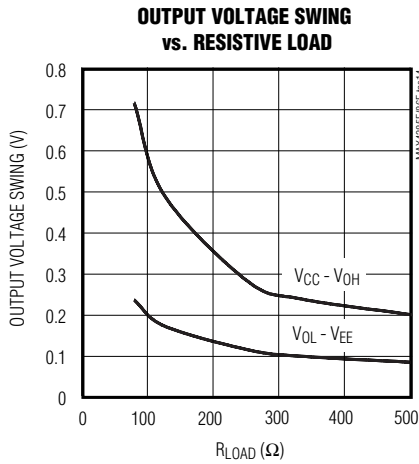
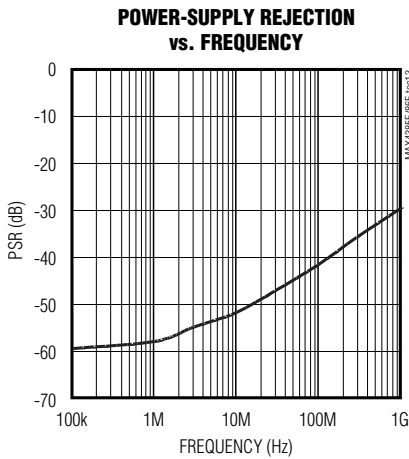
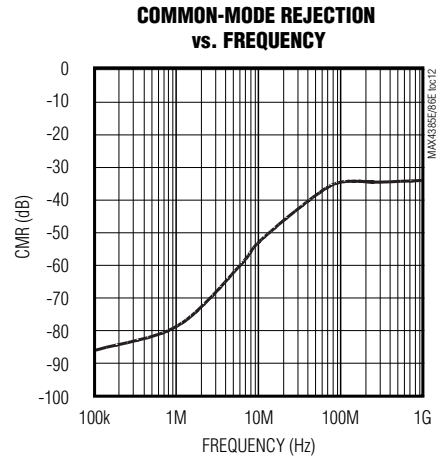
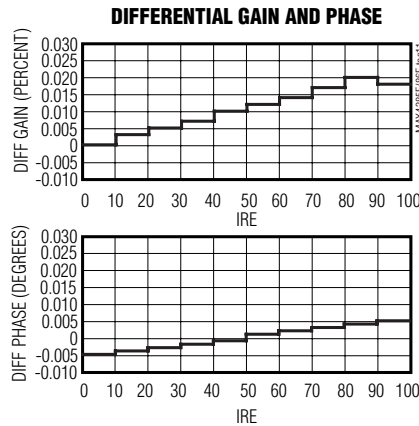
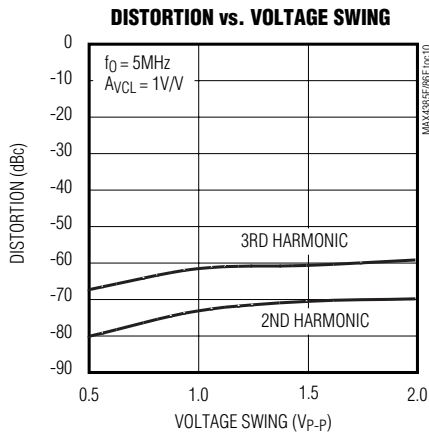

# Low-Cost, 230MHz, Single/Quad Op Amps with Rail-to-Rail Outputs and $\pm 15\text{kV}$ ESD Protection

## Typical Operating Characteristics (continued)

( $V_{CC} = 5\text{V}$ ,  $V_{EE} = 0$ ,  $V_{CM} = 1.5\text{V}$ ,  $A_{VCL} = 1\text{V/V}$ ,  $R_L = 100\Omega$  to  $V_{CC}/2$ ,  $T_A = +25^\circ\text{C}$ , unless otherwise noted.)

**LARGE-SIGNAL PULSE RESPONSE**

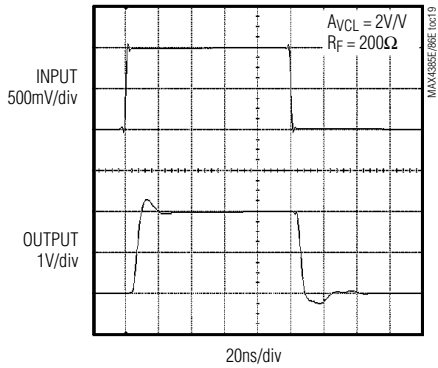

**LARGE-SIGNAL PULSE RESPONSE**

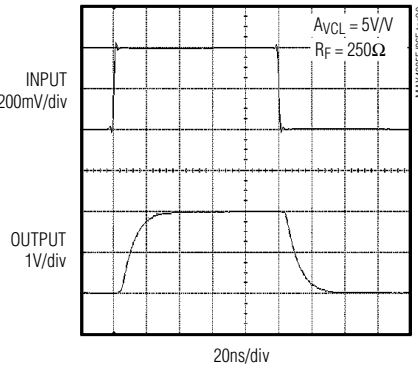

**VOLTAGE NOISE vs. FREQUENCY**

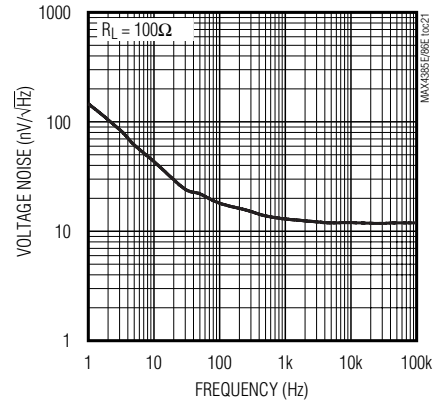

**CURRENT NOISE vs. FREQUENCY**

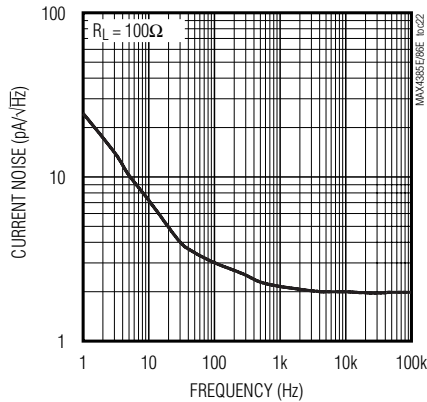

**ISOLATION RESISTANCE vs. CAPACITIVE LOAD**

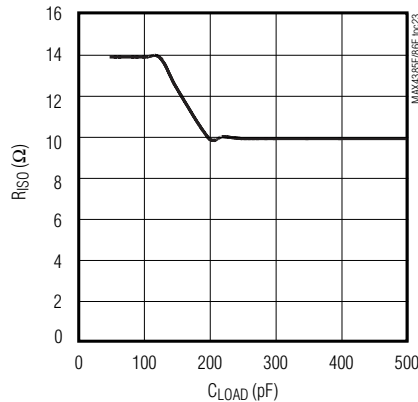

**SMALL-SIGNAL BANDWIDTH vs. LOAD RESISTANCE**

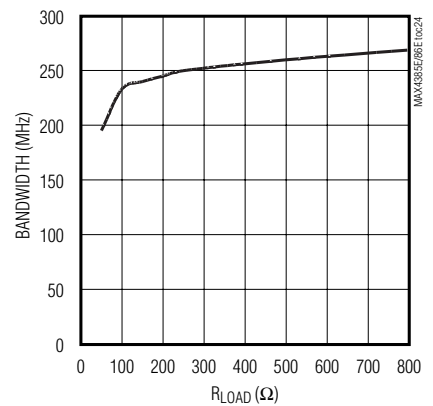

**OPEN-LOOP GAIN vs. RESISTIVE LOAD**

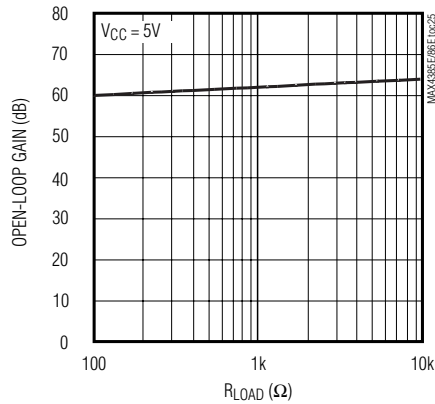

**CROSSTALK vs. FREQUENCY**

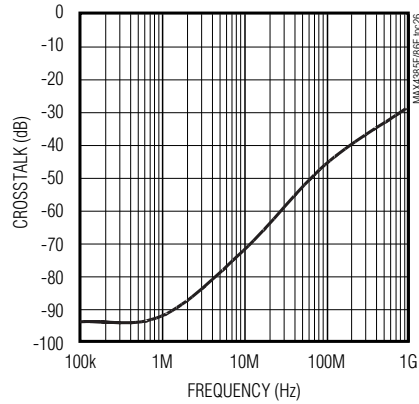

# Low-Cost, 230MHz, Single/Quad Op Amps with Rail-to-Rail Outputs and $\pm 15kV$ ESD Protection

## Typical Operating Characteristics (continued)

( $V_{CC} = 5V$ ,  $V_{EE} = 0$ ,  $V_{CM} = 1.5V$ ,  $A_{VCL} = 1V/V$ ,  $R_L = 100\Omega$  to  $V_{CC}/2$ ,  $T_A = +25^\circ C$ , unless otherwise noted.)

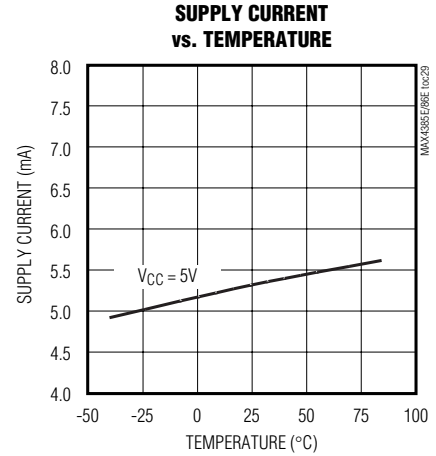
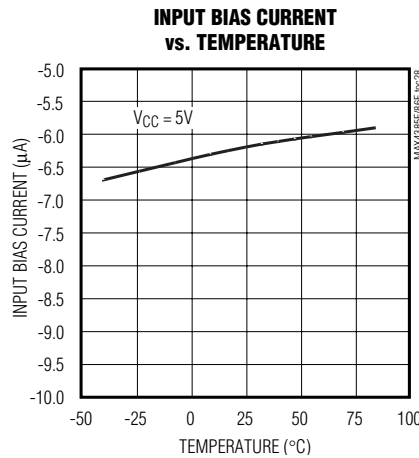
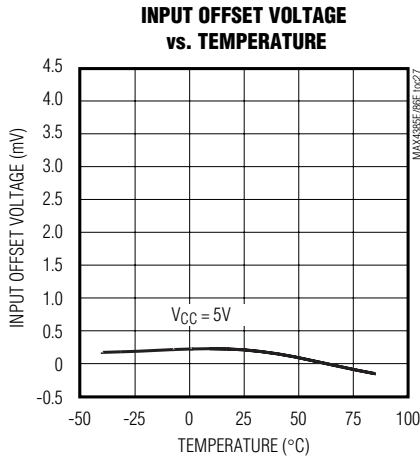

**MAX4385E/MAX4386E**

## Pin Description

PIN		NAME	FUNCTION
MAX4385E	MAX4386E		
SOT23	SO/TSSOP		
1	—	OUT	Amplifier Output
2	11	$V_{EE}$	Negative Power Supply
3	—	IN+	Noninverting Input
4	—	IN-	Inverting Input
5	4	$V_{CC}$	Positive Power Supply. Connect a 2.2 $\mu F$ and 0.1 $\mu F$ capacitor to GND.
—	1	OUTA	Amplifier A Output
—	2	INA-	Amplifier A Inverting Input
—	3	INA+	Amplifier A Noninverting Input
—	5	INB+	Amplifier B Noninverting Input
—	6	INB-	Amplifier B Inverting Input
—	7	OUTB	Amplifier B Output
—	8	OUTC	Amplifier C Output
—	9	INC-	Amplifier C Inverting Input
—	10	INC+	Amplifier C Noninverting Input
—	12	IND+	Amplifier D Noninverting Input
—	13	IND-	Amplifier D Inverting Input
—	14	OUTD	Amplifier D Output

# Low-Cost, 230MHz, Single/Quad Op Amps with Rail-to-Rail Outputs and $\pm 15\text{kV}$ ESD Protection

## Detailed Description

The MAX4385E/MAX4386E are single/quad, 5V, rail-to-rail, voltage-feedback amplifiers that employ current-feedback techniques to achieve  $450\text{V}/\mu\text{s}$  slew rates and 230MHz bandwidths. High  $\pm 15\text{kV}$  ESD protection guards against unexpected discharge. Excellent harmonic distortion and differential gain/phase performance make these amplifiers an ideal choice for a wide variety of video and RF signal-processing applications.

## Applications Information

The output voltage swings to within 50mV of each supply rail. Local feedback around the output stage ensures low open-loop output impedance to reduce gain sensitivity to load variations. The input stage permits common-mode voltages beyond  $V_{EE}$  and to within 2.25V of the positive supply rail.

### Choosing Resistor Values Unity-Gain Configuration

The MAX4385E/MAX4386E are internally compensated for unity gain. When configured for unity gain, a  $24\Omega$  resistor ( $R_F$ ) in series with the feedback path optimizes AC performance. This resistor improves AC response by reducing the Q of the parallel LC circuit formed by the parasitic feedback capacitance and inductance.

### Video Line Driver

The MAX4385E/MAX4386E are low-power, voltage-feedback amplifiers featuring bandwidths up to 230MHz, 0.1dB gain flatness to 30MHz. They are designed to minimize differential-gain error and differential-phase error to 0.02% and  $0.01^\circ$ , respectively. They have a 14ns settling time to 0.1%,  $450\text{V}/\mu\text{s}$  slew rates, and output-current-drive capability of up to 50mA, making them ideal for driving video loads.

### Inverting and Noninverting Configurations

Select the gain-setting feedback ( $R_F$ ) and input ( $R_G$ ) resistor values to fit your application. Large resistor values increase voltage noise and interact with the amplifier's input and PC board capacitance. This can generate undesirable poles and zeros and decrease bandwidth or cause oscillations. For example, a noninverting gain-of-two configuration ( $R_F = R_G$ ) using  $1\text{k}\Omega$  resistors, combined with 8pF of amplifier input capacitance and 1pF of PC board capacitance, causes a pole at 35.4MHz. Since this pole is within the amplifier bandwidth, it jeopardizes stability. Reducing the  $1\text{k}\Omega$  resistors to  $100\Omega$  extends the pole frequency to 353.8MHz, but could limit output swing by adding  $200\Omega$  in parallel with the amplifier's load resistor (Figures 1a and 1b).

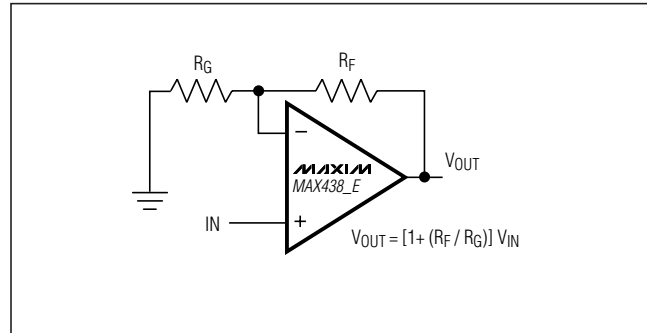

Figure 1a. Noninverting Gain Configuration

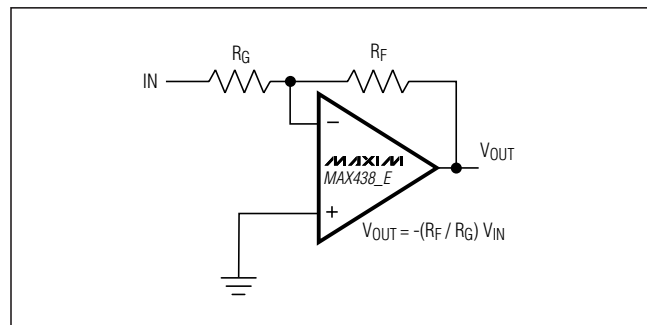

Figure 1b. Inverting Gain Configuration

### Layout and Power-Supply Bypassing

These amplifiers operate from a single 5V power supply. Bypass  $V_{CC}$  to ground with  $0.1\mu\text{F}$  and  $2.2\mu\text{F}$  capacitors as close to the pin as possible.

Maxim recommends using microstrip and stripline techniques to obtain full bandwidth. To ensure that the PC board does not degrade the amplifier's performance, design it for a frequency greater than 1GHz. Pay careful attention to inputs and outputs to avoid large parasitic capacitance. Regardless of whether you use a constant-impedance board, observe the following design guidelines:

- Do not use wire-wrap boards; they are too inductive.
- Do not use IC sockets; they increase parasitic capacitance and inductance.
- Use surface mount instead of through-hole components for better high-frequency performance.
- Use a PC board with at least two layers; it should be as free from voids as possible.
- Keep signal lines as short and as straight as possible. Do not make  $90^\circ$  turns; round all corners.



# Low-Cost, 230MHz, Single/Quad Op Amps with Rail-to-Rail Outputs and $\pm 15\text{kV}$ ESD Protection

**MAX4385E/MAX4386E**

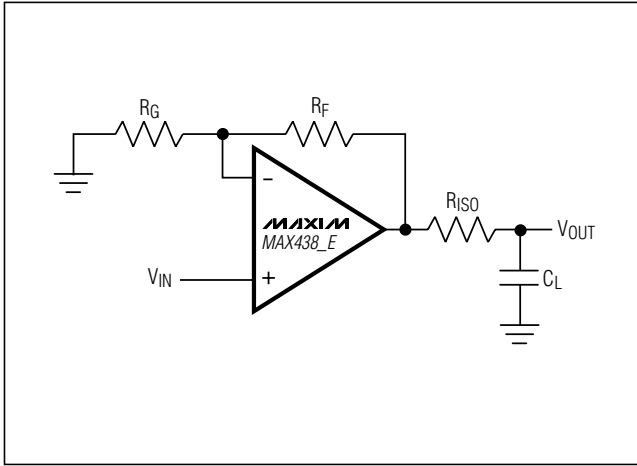

Figure 2. Driving a Capacitive Load Through an Isolation Resistor

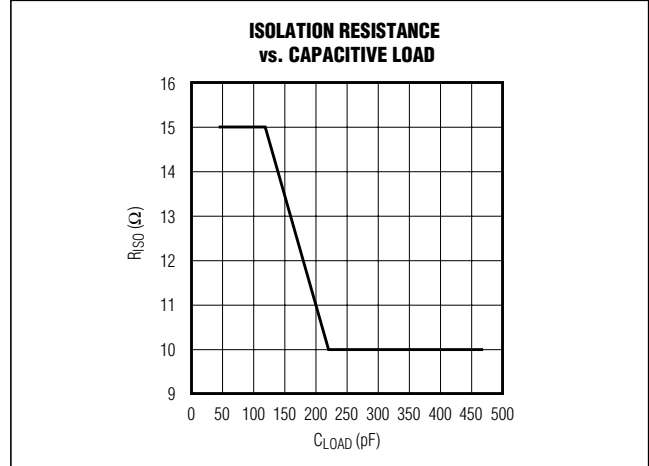

Figure 3. Isolation Resistance vs. Capacitive Load

## Rail-to-Rail Outputs, Ground-Sensing Inputs

The input common-mode range extends from ( $V_{EE} - 200\text{mV}$ ) to ( $V_{CC} - 2.25\text{V}$ ) with excellent common-mode rejection. Beyond this range, the amplifier output is a nonlinear function of the input, but does not undergo phase reversal or latchup.

The output swings to within 50mV of either power-supply rail with a 2k $\Omega$  load. The input ground sensing and the rail-to-rail output substantially increase the dynamic range. The input can swing 2.95V<sub>P-P</sub> and the output can swing 4.9V<sub>P-P</sub> with minimal distortion.

## Output Capacitive Loading and Stability

The MAX4385E/MAX4386E are optimized for AC performance and do not drive highly reactive loads, which decreases phase margin and may produce excessive ringing and oscillation. Figure 2 shows a circuit that eliminates this problem. Figure 3 is a graph of the Optimal Isolation Resistor ( $R_S$ ) vs. Capacitive Load. Figure 4 shows how a capacitive load causes excessive peaking of the amplifier's frequency response if the capacitor is not isolated from the amplifier by a resistor. A small isolation resistor (usually 10 $\Omega$  to 15 $\Omega$ ) placed before the reactive load prevents ringing and oscillation. At higher capacitive loads, the interaction of the load capacitance and the isolation resistor controls the AC performance. Figure 5 shows the effect of a 15 $\Omega$  isolation resistor on closed-loop response.

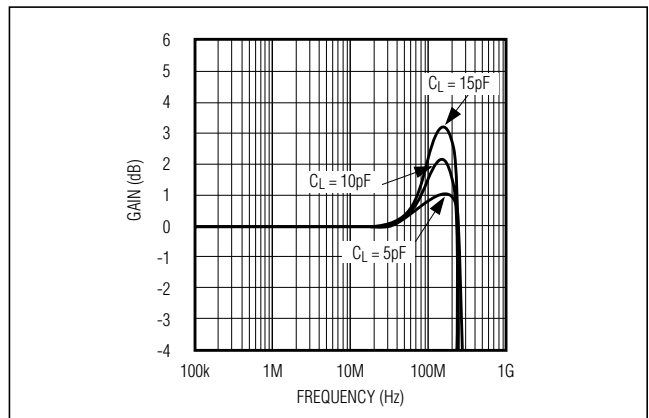

Figure 4. Small-Signal Gain vs. Frequency with Load Capacitance and No Isolation Resistor

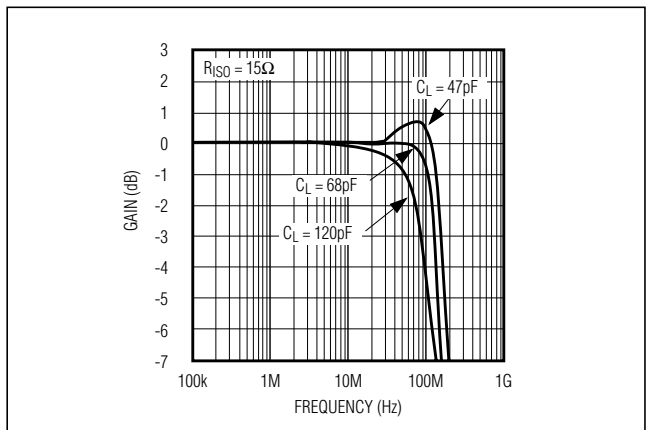

Figure 5. Small-Signal Gain vs. Frequency with Load Capacitance and 27 $\Omega$  Isolation Resistor

# Low-Cost, 230MHz, Single/Quad Op Amps with Rail-to-Rail Outputs and ±15kV ESD Protection

## ESD Protection

As with all Maxim devices, ESD protection structures are incorporated on all pins to protect against ESD encountered during handling and assembly. Input and output pins of the MAX4385E/MAX4386E have extra protection against static electricity. Maxim's engineers have developed state-of-the-art structures enabling these pins to withstand ESD up to ±15kV without damage when placed in the test circuit (Figure 6). The MAX4385E/MAX4386E are characterized for protection to the following limits:

- ±15kV using the Human Body Model
- ±8kV using the Contact Discharge method specified in IEC 1000-4-2
- ±15kV using the Air-Gap Discharge method specified in IEC 1000-4-2

## Human Body Model

Figure 7 shows the Human Body Model, and Figure 8 shows the current waveform it generates when discharged into a low impedance. This model consists of a 150pF capacitor charged to the ESD voltage of interest, and then discharged into the test device through a 1.5kΩ resistor.

## IEC 1000-4-2

The IEC 1000-4-2 standard covers ESD testing and performance of finished equipment; it does not specifically refer to ICs. The MAX4385E/MAX4386E enable the design of equipment that meets the highest level (Level 4) of IEC 1000-4-2 without the need for additional ESD protection components. The major difference between tests done using the Human Body Model and IEC 1000-4-2 is higher peak current in IEC 1000-4-2. Because series resistance is lower in the IEC 1000-4-2 model, the ESD-withstand voltage measured to this standard is generally lower than that measured using the Human Body Model. Figure 10 shows the IEC 1000-4-2 model and Figure 9 shows the current waveform for the ±8kV IEC 1000-4-2 Level 4 ESD Contact Discharge test. The Air-Gap test involves approaching the device with a charged probe. The Contact Discharge method connects the probe to the device before the probe is energized.

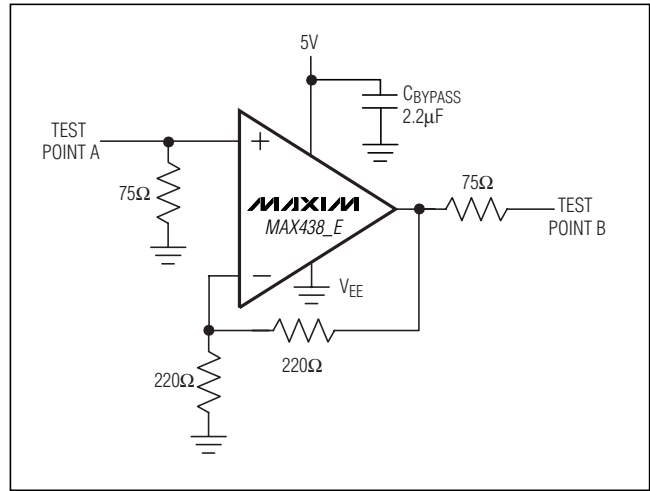

Figure 6. ESD Test Circuit

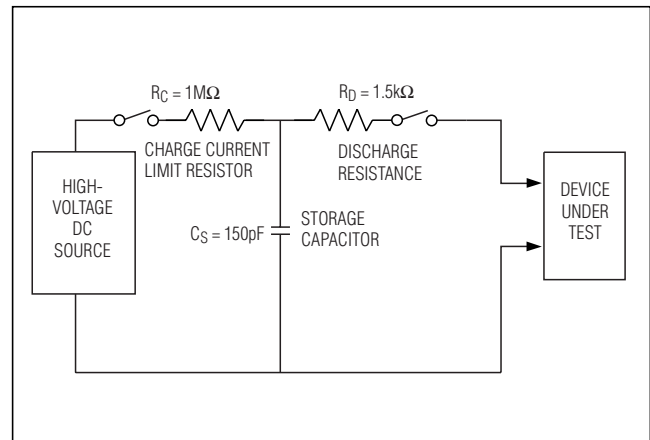

Figure 7. Human Body ESD Model

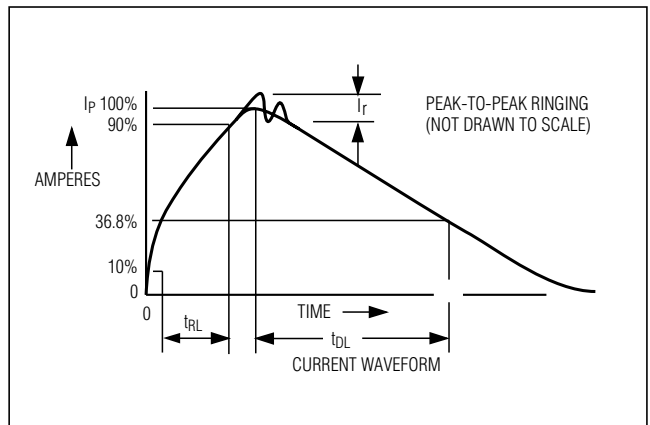

Figure 8. Human Body Current Waveform

# Low-Cost, 230MHz, Single/Quad Op Amps with Rail-to-Rail Outputs and $\pm 15\text{kV}$ ESD Protection

**MAX4385E/MAX4386E**

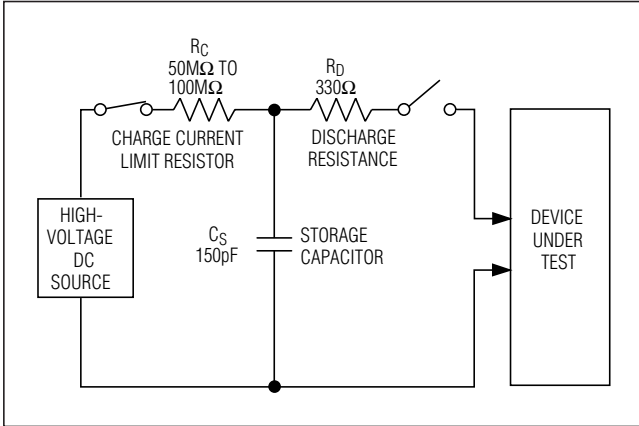

Figure 9. IEC 1000-4-2 ESD Test Model

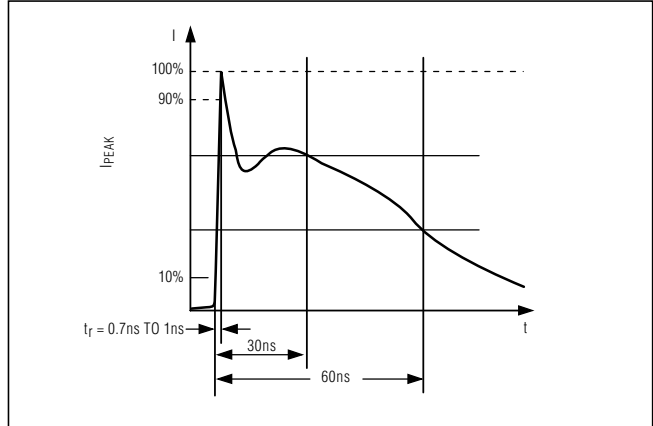
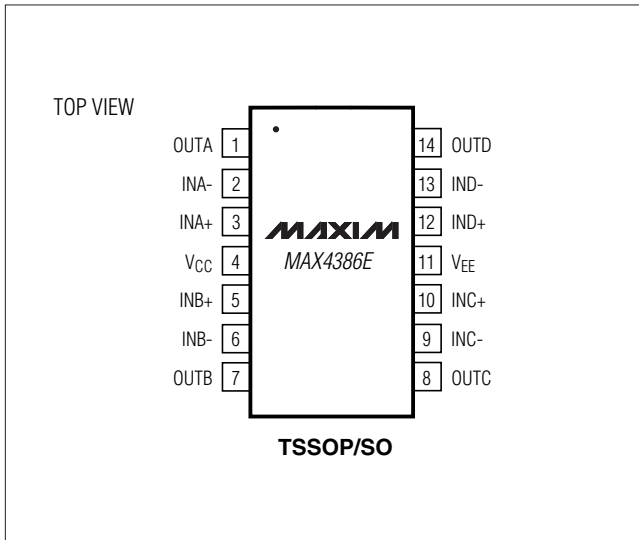

Figure 10. IEC 1000-4-2 ESD Generator Current Waveform

## Pin Configurations (continued)



## Chip Information

MAX4385E TRANSISTOR COUNT: 124

MAX4386E TRANSISTOR COUNT: 264

# Low-Cost, 230MHz, Single/Quad Op Amps with Rail-to-Rail Outputs and ±15kV ESD Protection

## Package Information

(The package drawing(s) in this data sheet may not reflect the most current specifications. For the latest package outline information, go to [www.maxim-ic.com/packages](http://www.maxim-ic.com/packages).)

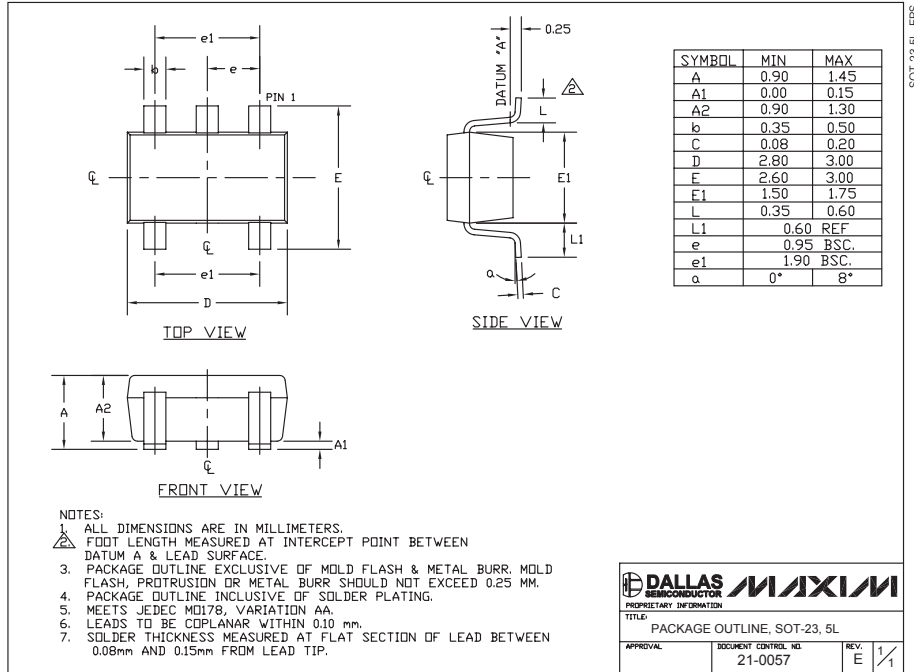

SOT-23 5L EPS

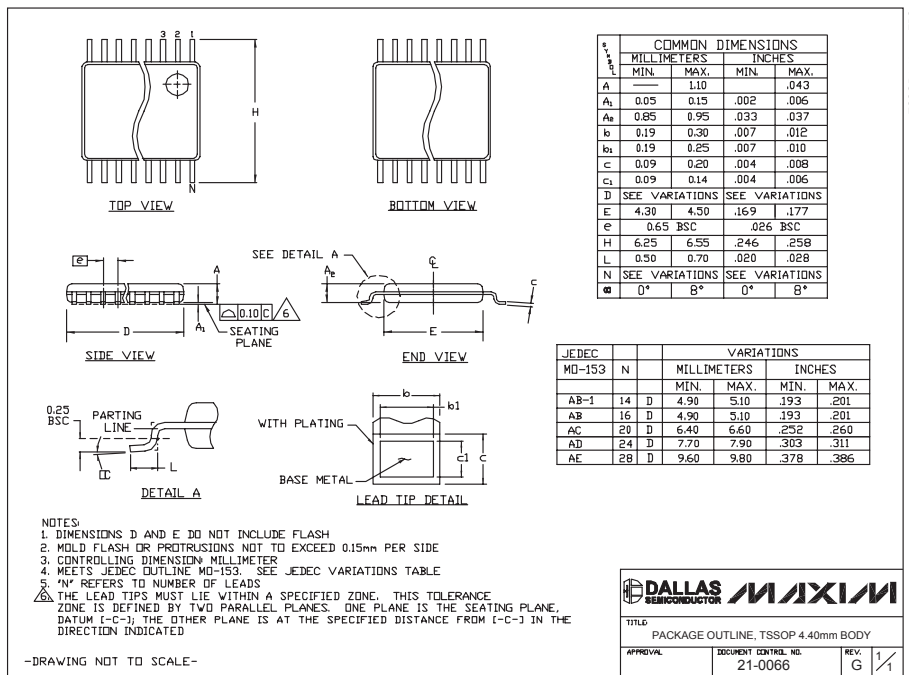

TSSOP4 40mm EPS

# Low-Cost, 230MHz, Single/Quad Op Amps with Rail-to-Rail Outputs and $\pm 15kV$ ESD Protection

## Package Information (continued)

(The package drawing(s) in this data sheet may not reflect the most current specifications. For the latest package outline information, go to [www.maxim-ic.com/packages](http://www.maxim-ic.com/packages).)

MAX4385E/MAX4386E

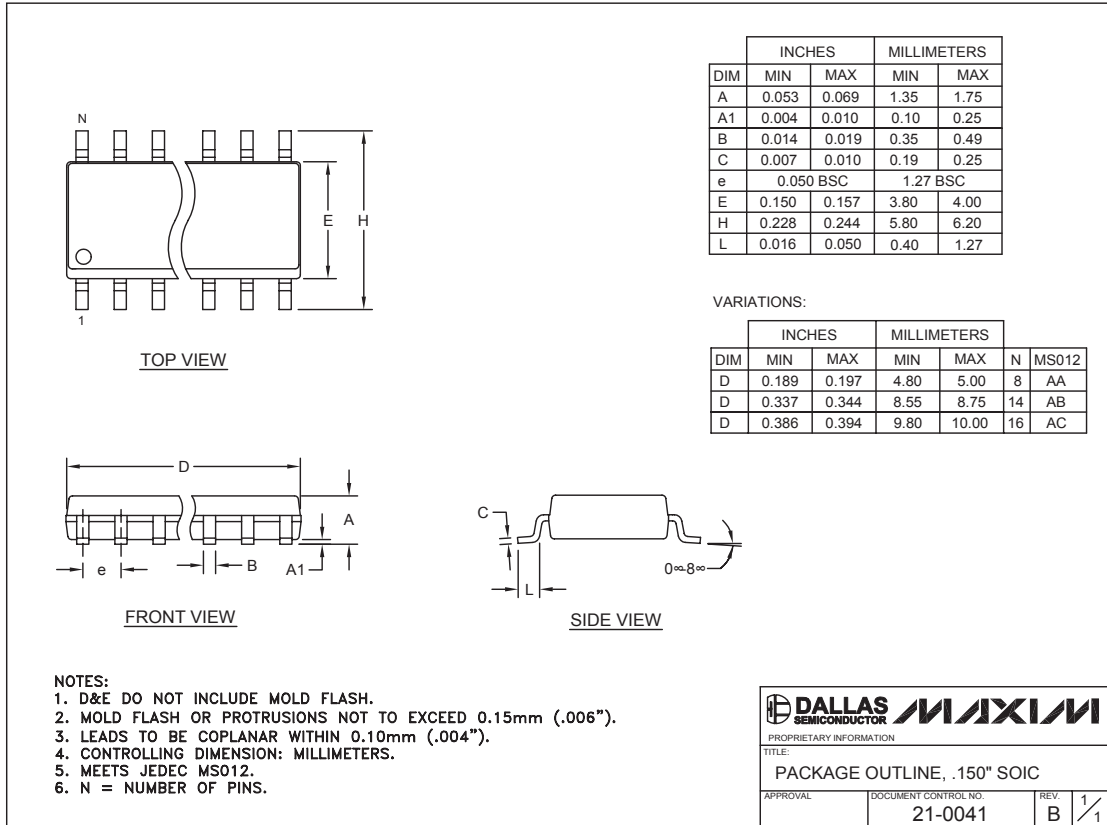

Maxim cannot assume responsibility for use of any circuitry other than circuitry entirely embodied in a Maxim product. No circuit patent licenses are implied. Maxim reserves the right to change the circuitry and specifications without notice at any time.

Maxim Integrated Products, 120 San Gabriel Drive, Sunnyvale, CA 94086 408-737-7600 13