



# M1 20 Series Compression Latch

Medium · Cast 316 stainless steel · Lift & turn · Adjustable grip

- Consistent pre-set compression
- Easy grip adjustment
- Flush round hole install

### Material and Finish

Cast 316 grade stainless steel

### Performance Details

Short cam

Max. static load: 460 N (103 lbf)

Long cam

Max. static load: 350 N (78 lbf)

### Sealing Notes

NEMA 4/IP-66 sealing is achieved by using supplied flange gasket

### Keys

Lock style 8

Part number: M1-546

Lock style 9



Part number: M1-525-39-S008

### Part Number Selection

See page 151 for complimentary styled push to close version

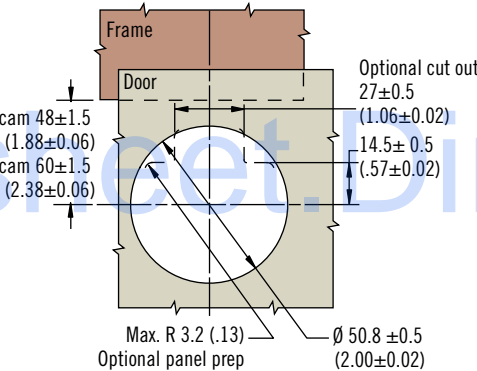
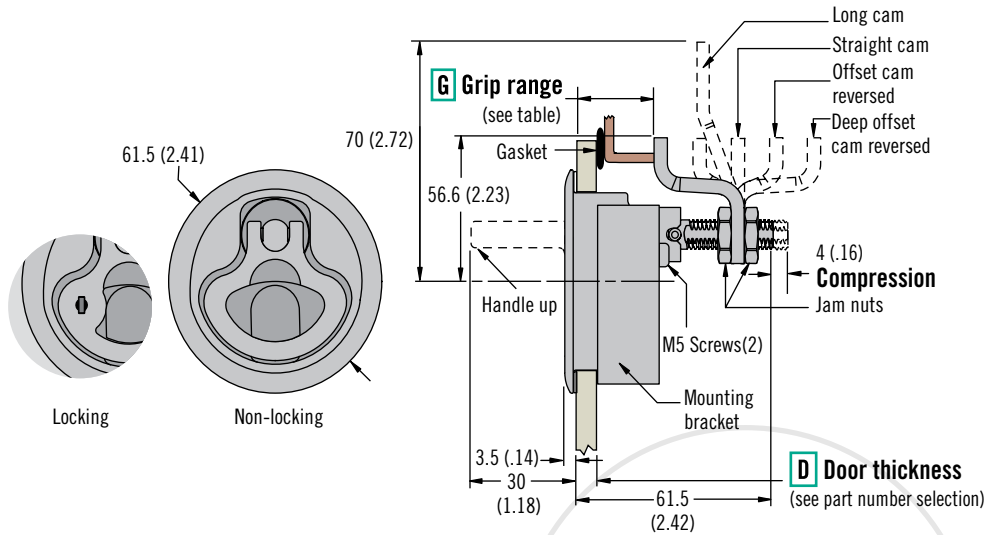

- L Lock style**
- 3 Non-locking
  - 8 Locking (2 keys supplied)
  - 9 Key-locking keyed alike S008 (2 overmolded keys supplied)

**M1 - 20 - L D - G 8**

D	Door Thickness	Grip Adjustment Value
1	2 - 12 (.075 - .475)	19 (.75)
2	12 - 22.5 (.475 - .885)	9 (.35)
3	18.5 - 29 (.73 - 1.14)	2.5 (.10)

G Grip Range		
Short cam		
5	21 - 28 (.83 - 1.10)	Deep offset forward
4	27 - 40 (1.06 - 1.57)	Offset forward
3	39 - 52 (2.01 - 2.52)	Straight
4	51 - 64 (2.01 - 2.52)	Offset reversed
5	63 - 76 (2.48 - 3.00)	Deep offset reversed
Long cam		
8	21 - 28 (.83 - 1.10)	Deep offset forward
7	27 - 40 (1.06 - 1.57)	Offset forward
6	39 - 52 (2.01 - 2.52)	Straight
7	51 - 64 (2.01 - 2.52)	Offset reversed
8	63 - 76 (2.48 - 3.00)	Deep offset reversed

### Note

All grips of 35 (1.38) or below, highlighted in   , in the table above, are potentially a function of door thickness and may not always be achievable, depending on actual door thickness used. In this range of grips, the minimum achievable grip will be limited to actual door thickness + grip adjustment value, or the minimum values shown in the table, whichever is greater.

Examples:

For a door thickness of 4 mm, the minimum achievable grip is 23 and is achieved with a deep offset cam in the forward position. (4 + 19 = 23)

For a door thickness of 20 mm, the minimum achievable grip is 29 and is achieved with an offset cam in the forward position. (20 + 9 = 29)

Dimensions in millimeters (inch) unless otherwise stated



[www.southco.com/M1A](http://www.southco.com/M1A)

# M1 25 Series Compression Latch

Large · Cast 316 stainless steel · Lift & turn · Adjustable grip

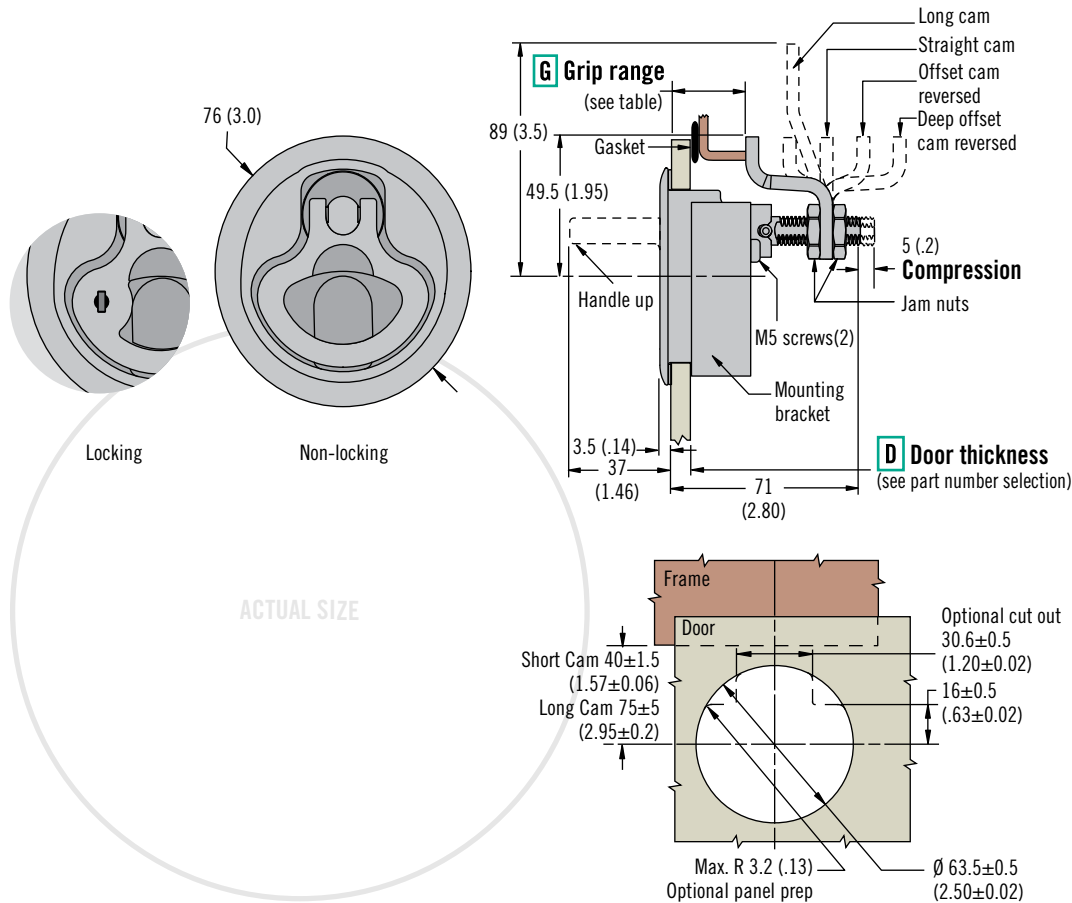

- Consistent pre-set compression
- Easy grip adjustment

### Material and Finish

Stainless steel cast 316 grade

### Performance Details

Short cam

Max. static load: 1010 N (227 lbf)

Long cam

Max. static load: 350 N (78 lbf)

### Sealing Notes

NEMA 4/IP-66 sealing is achieved by using supplied flange gasket

### Keys

Lock style 8

Part number: M1-546

Lock style 9



Part number: M1-525-39-S008

### Part Number Selection

See page 152 for complimentary styled push to close version

**L Lock style**

- 3 Non-locking
- 8 Locking (2 keys supplied)
- 9 Key-locking keyed alike S008 (2 overmolded keys supplied)

**M1 - 25 - L D - G 8**

D	Door Thickness	Grip Adjustment Value
1	2 - 12 (.075 - .475)	21.5 (.85)
2	12 - 22.5 (.475 - .885)	11.5 (.45)
3	18.5 - 29 (.73 - 1.14)	4 (.12)

G Grip Range		
Short cam		
5	23.5 - 35 (.92 - 1.38)	Deep offset forward
4	34 - 48 (1.34 - 1.89)	Offset forward
3	47 - 61 (1.85 - 2.40)	Straight
4	60 - 75 (2.36 - 2.95)	Offset reversed
5	74 - 88 (2.91 - 3.47)	Deep offset reversed
Long cam		
8	23.5 - 35 (.92 - 1.38)	Deep offset forward
7	34 - 48 (1.34 - 1.89)	Offset forward
6	47 - 61 (1.85 - 2.40)	Straight
7	60 - 75 (2.36 - 2.95)	Offset reversed
8	74 - 88 (2.91 - 3.47)	Deep offset reversed

### Note

All grips of 33.5 (1.32) or below, highlighted in   , in the table above, are potentially a function of door thickness and may not always be achievable, depending on actual door thickness used. In this range of grips, the minimum achievable grip will be limited to actual door thickness + grip adjustment value, or the minimum values shown in the table, whichever is greater.

### Examples:

For a door thickness of 4 mm, the minimum achievable grip is 25.5 and is achieved with a deep offset cam in the forward position. (4 + 21.5 = 25.5)

For a door thickness of 20 mm, the minimum achievable grip is 31.5 and is achieved with a deep offset cam in the forward position. (20 + 11.5 = 31.5)

