

CentralTM Semiconductor Corp.

145 Adams Avenue, Hauppauge, NY 11788 USA
Tel: (631) 435-1110 • Fax: (631) 435-1824

Manufacturers of World Class Discrete Semiconductors

BC327
BC327A
BC328

PNP SILICON TRANSISTOR

JEDEC TO-92-18R CASE

DESCRIPTION

The CENTRAL SEMICONDUCTOR BC327, BC327A, BC328 types are Silicon PNP Transistors designed for general purpose switching and amplifier applications.

MAXIMUM RATINGS (T_A=25°C)

	SYMBOL	BC327	BC327A	BC328	UNITS
Collector-Base Voltage	V _{CBO}	50	60	30	V
Collector-Emitter Voltage	V _{CEO}	45	60	25	V
Emitter-Base Voltage	V _{EBO}		5.0		V
Collector Current	I _C		500		mA
Peak Collector Current	I _{CM}		1.0		A
Base Current	I _B		100		mA
Peak Base Current	I _{BM}		200		mA
Power Dissipation	P _D		625		mW
Operating and Storage Junction Temperature	T _J , T _{stg}		-65 to +150		°C
Thermal Resistance	θ _{JA}		200		°C/W

ELECTRICAL CHARACTERISTICS (T_A=25°C unless otherwise noted)

SYMBOL	TEST CONDITIONS	MIN	TYP	MAX	UNITS
I _{CBO}	V _{CB} =20V			100	nA
I _{CBO}	V _{CB} =20V, T _A =150°C			5.0	μA
I _{EBO}	V _{EB} =5.0V			100	nA
V _{CE(SAT)}	I _C =500mA, I _B =50mA			0.7	V
V _{BE(ON)}	V _{CE} =1.0V, I _C =500mA			1.2	V
h _{FE}	V _{CE} =1.0V, I _C =100mA (BC327, BC328)	100		600	
h _{FE}	V _{CE} =1.0V, I _C =100mA (BC327A)	100		400	
h _{FE}	V _{CE} =1.0V, I _C =100mA (BC327-16, BC328-16)	100		250	
h _{FE}	V _{CE} =1.0V, I _C =100mA (BC327-25, BC328-25)	160		400	
h _{FE}	V _{CE} =1.0V, I _C =100mA (BC327-40, BC328-40)	250		600	
h _{FE}	V _{CE} =1.0V, I _C =500mA (All Types)	40			
f _T	V _{CE} =5.0V, I _C =10mA, f=100MHz	80			MHz
C _c	V _{CB} =10V, I _E =0, f=1.0MHz		10		pF

(See Reverse Side)

JEDEC TO-92-18R - MECHANICAL OUTLINE

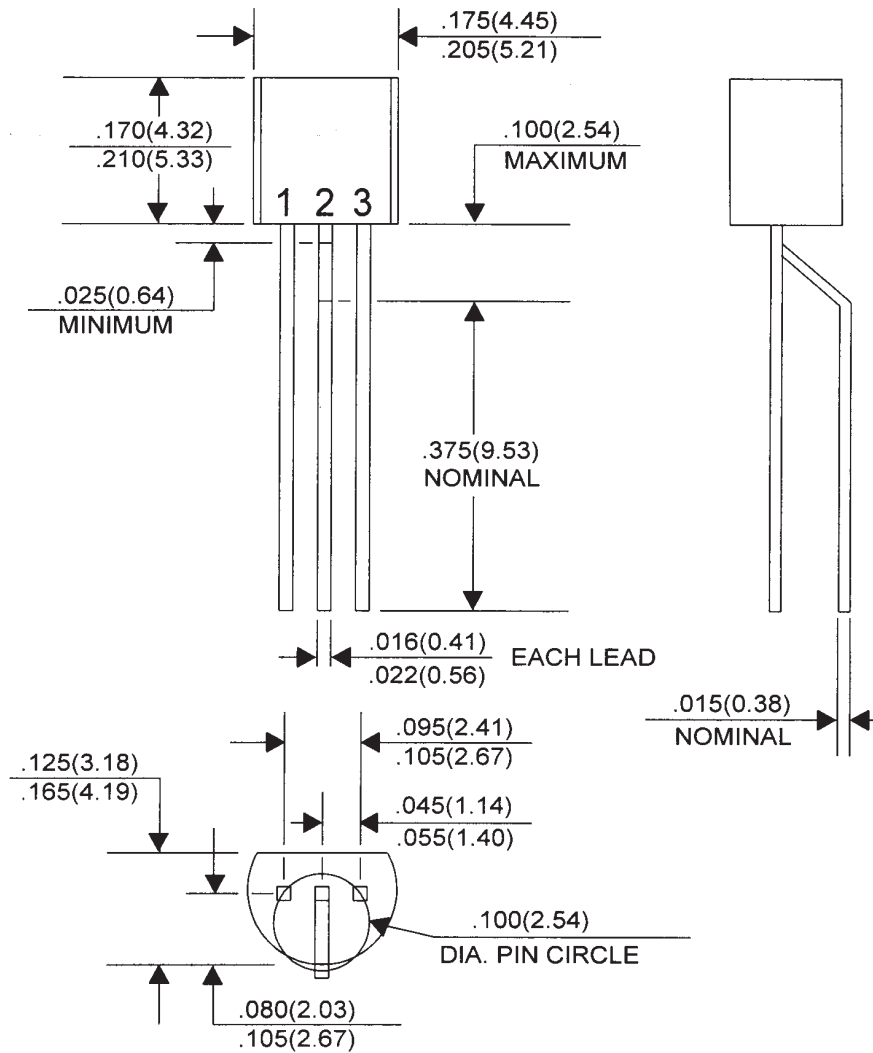

All Dimensions in Inches (mm).

LEAD CODE:

- 1) COLLECTOR
- 2) BASE
- 3) EMITTER