

**LM5112**

*LM5112 Tiny 7A MOSFET Gate Driver*

# Datasheet.Directory



Literature Number: SNVS234B

# LM5112

## Tiny 7A MOSFET Gate Driver

### General Description

The LM5112 MOSFET gate driver provides high peak gate drive current in the tiny LLP-6 package (SOT23 equivalent footprint) or an 8-Lead exposed-pad MSOP package, with improved power dissipation required for high frequency operation. The compound output driver stage includes MOS and bipolar transistors operating in parallel that together sink more than 7A peak from capacitive loads. Combining the unique characteristics of MOS and bipolar devices reduces drive current variation with voltage and temperature. Under-voltage lockout protection is provided to prevent damage to the MOSFET due to insufficient gate turn-on voltage. The LM5112 provides both inverting and non-inverting inputs to satisfy requirements for inverting and non-inverting gate drive with a single device type.

### Features

- Compound CMOS and bipolar outputs reduce output current variation
- 7A sink/3A source current
- Fast propagation times (25 ns typical)
- Fast rise and fall times (14 ns/12 ns rise/fall with 2 nF load)
- Inverting and non-inverting inputs provide either configuration with a single device
- Supply rail under-voltage lockout protection
- Dedicated input ground (IN\_REF) for split supply or single supply operation
- Power Enhanced 6-pin LLP package (3.0mm x 3.0mm) or thermally enhanced MSOP8-EP package
- Output swings from  $V_{CC}$  to  $V_{EE}$  which can be negative relative to input ground

### Block Diagram

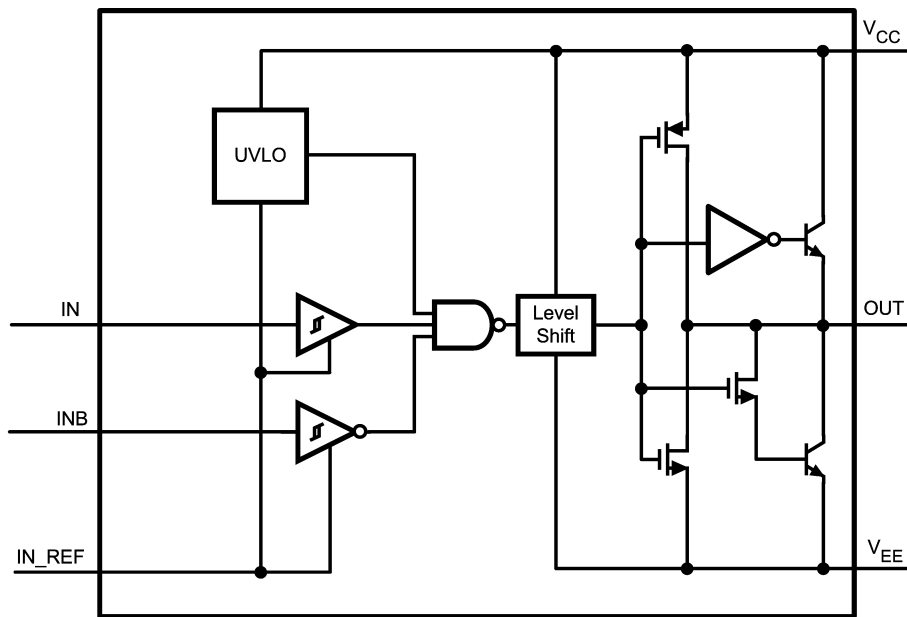

Block Diagram of LM5112

20066801

## Pin Configurations

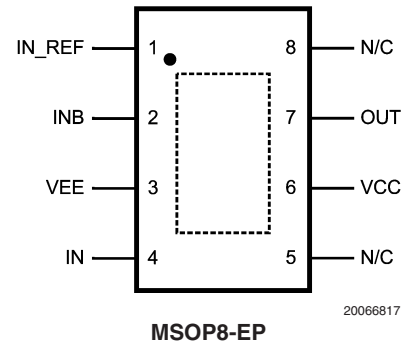
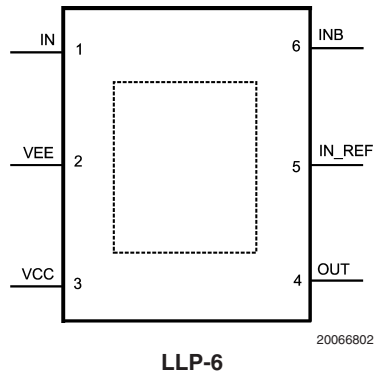

## Ordering Information

Order Number	Package Type	NSC Package Drawing	Supplied As
LM5112MY	Exposed DAP MSOP8-EP	MUY08A	1000 shipped in Tape & Reel
LM5112MYX	Exposed DAP MSOP8-EP	MUY08A	3500 shipped in Tape & Reel
LM5112SD	LLP-6	SDE06A	1000 shipped in Tape & Reel
LM5112SDX	LLP-6	SDE06A	4500 shipped in Tape & Reel

## Pin Descriptions

Pin		Name	Description	Application Information
LLP-6	MSOP-8			
1	4	IN	Non-inverting input pin	TTL compatible thresholds. Pull up to VCC when not used.
2	3	VEE	Power ground for driver outputs	Connect to either power ground or a negative gate drive supply for positive or negative voltage swing.
3	6	VCC	Positive Supply voltage input	Locally decouple to VEE. The decoupling capacitor should be located close to the chip.
4	7	OUT	Gate drive output	Capable of sourcing 3A and sinking 7A. Voltage swing of this output is from VEE to VCC.
5	1	IN_REF	Ground reference for control inputs	Connect to power ground (VEE) for standard positive only output voltage swing. Connect to system logic ground when VEE is connected to a negative gate drive supply.
6	2	INB	Inverting input pin	TTL compatible thresholds. Connect to IN_REF when not used.
- - -	5, 8	N/C	Not internally connected	
- - -	- - -	Exposed Pad	Exposed Pad, underside of package	Internally bonded to the die substrate. Connect to VEE ground pin for low thermal impedance.

**Absolute Maximum Ratings** (Note 1)

If Military/Aerospace specified devices are required, please contact the National Semiconductor Sales Office/Distributors for availability and specifications.

$V_{CC}$ to $V_{EE}$	-0.3V to 15V
$V_{CC}$ to IN_REF	-0.3V to 15V
IN/INB to IN_REF	-0.3V to 15V

IN_REF to $V_{EE}$	-0.3V to 5V
Storage Temperature Range	-55°C to +150°C
Maximum Junction Temperature	+150°C
Operating Junction Temperature	-40°C to +125°C
ESD Rating	2kV

**Electrical Characteristics**  $T_J = -40^\circ\text{C}$  to  $+125^\circ\text{C}$ ,  $V_{CC} = 12\text{V}$ ,  $\text{INB} = \text{IN\_REF} = V_{EE} = 0\text{V}$ , No Load on output, unless otherwise specified.

SYMBOL	PARAMETER	CONDITIONS	MIN	TYP	MAX	UNITS
<b>SUPPLY</b>						
$V_{CC}$	$V_{CC}$ Operating Range	$V_{CC} - \text{IN\_REF}$ and $V_{CC} - V_{EE}$	3.5		14	V
UVLO	$V_{CC}$ Under-voltage Lockout (rising)	$V_{CC} - \text{IN\_REF}$	2.4	3.0	3.5	V
$V_{CCH}$	$V_{CC}$ Under-voltage Hysteresis			230		mV
$I_{CC}$	$V_{CC}$ Supply Current			1.0	2.0	mA
<b>CONTROL INPUTS</b>						
$V_{IH}$	Logic High		2.3			V
$V_{IL}$	Logic Low				0.8	V
$V_{thH}$	High Threshold		1.3	1.75	2.3	V
$V_{thL}$	Low Threshold		0.8	1.35	2.0	V
HYS	Input Hysteresis			400		mV
$I_{IL}$	Input Current Low	$\text{IN} = \text{INB} = 0\text{V}$	-1	0.1	1	$\mu\text{A}$
$I_{IH}$	Input Current High	$\text{IN} = \text{INB} = V_{CC}$	-1	0.1	1	$\mu\text{A}$
<b>OUTPUT DRIVER</b>						
$R_{OH}$	Output Resistance High	$I_{OUT} = -10\text{mA}$ (Note 2)		30	50	$\Omega$
$R_{OL}$	Output Resistance Low	$I_{OUT} = 10\text{mA}$ (Note 2)		1.4	2.5	$\Omega$
$I_{SOURCE}$	Peak Source Current	$\text{OUT} = V_{CC}/2$ , 200ns pulsed current		3		A
$I_{SINK}$	Peak Sink Current	$\text{OUT} = V_{CC}/2$ , 200ns pulsed current		7		A
<b>SWITCHING CHARACTERISTICS</b>						
td1	Propagation Delay Time Low to High, IN/ INB rising ( IN to OUT)	$C_{LOAD} = 2\text{ nF}$ , see Figure 1		25	40	ns
td2	Propagation Delay Time High to Low, IN / INB falling (IN to OUT)	$C_{LOAD} = 2\text{ nF}$ , see Figure 1		25	40	ns
tr	Rise time	$C_{LOAD} = 2\text{ nF}$ , see Figure 1		14		ns
tf	Fall time	$C_{LOAD} = 2\text{ nF}$ , see Figure 1		12		ns
<b>LATCHUP PROTECTION</b>						
	AEC -Q100, METHOD 004	$T_J = 150^\circ\text{C}$		500		mA
<b>THERMAL RESISTANCE</b>						
$\theta_{JA}$	Junction to Ambient, 0 LFPM Air Flow	LLP-6 Package MSOP8-EP Package		40 60		$^\circ\text{C/W}$
$\theta_{JC}$	Junction to Case	LLP-6 Package MSOP8-EP Package		7.5 4.7		$^\circ\text{C/W}$

**Note 1:** Absolute Maximum Ratings are limits beyond which damage to the device may occur. Operating Ratings are conditions under which operation of the device is intended to be functional. For guaranteed specifications and test conditions, see the Electrical Characteristics.

**Note 2:** The output resistance specification applies to the MOS device only. The total output current capability is the sum of the MOS and Bipolar devices.

# Timing Waveforms

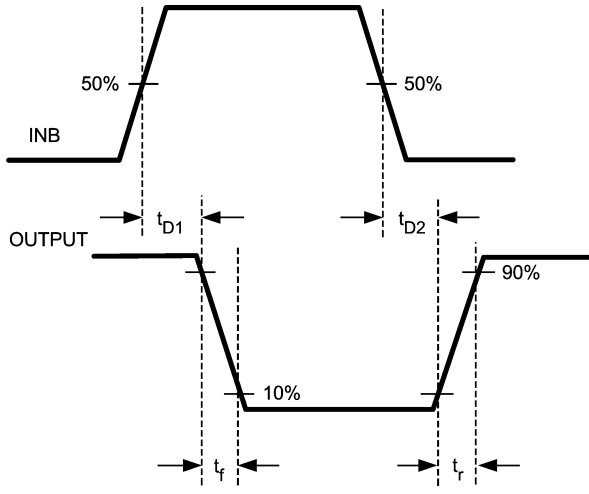

20066804

(a)

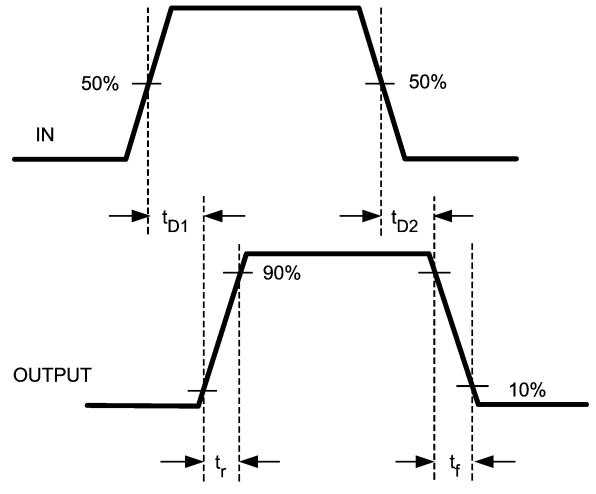

20066805

(b)

FIGURE 1. (a) Inverting, (b) Non-Inverting

# Typical Performance Characteristics

Supply Current vs Frequency

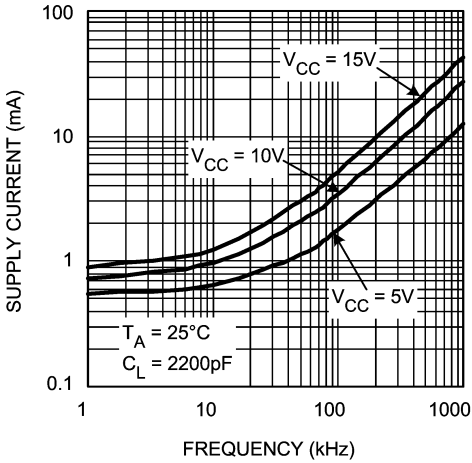

20066807

Supply Current vs Capacitive Load

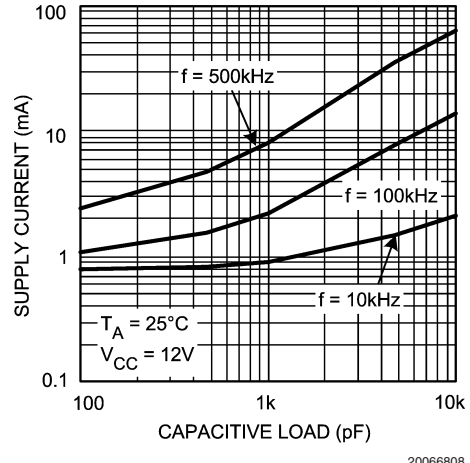

20066808

Rise and Fall Time vs Supply Voltage

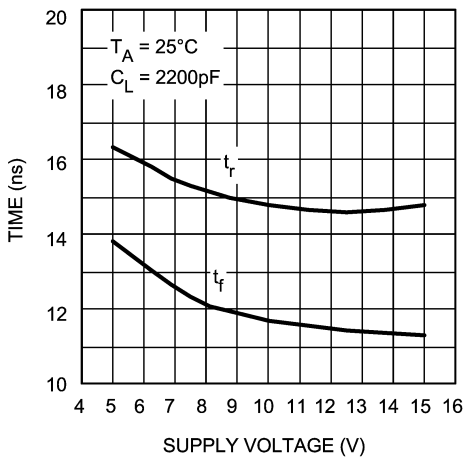

20066809

Rise and Fall Time vs Temperature

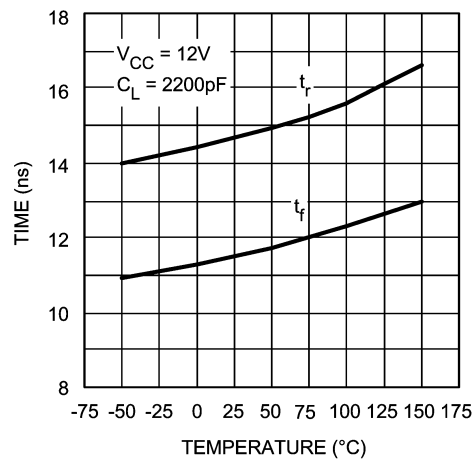

20066810

Rise and Fall Time vs Capacitive Load

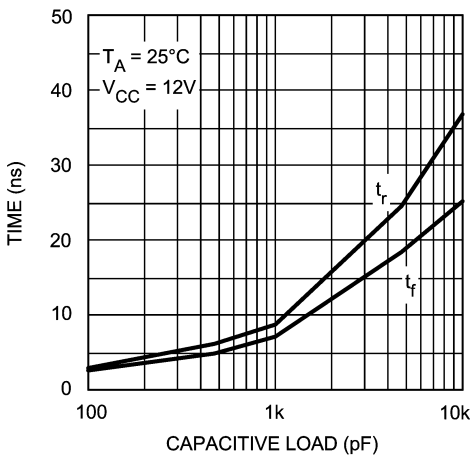

20066811

Delay Time vs Supply Voltage

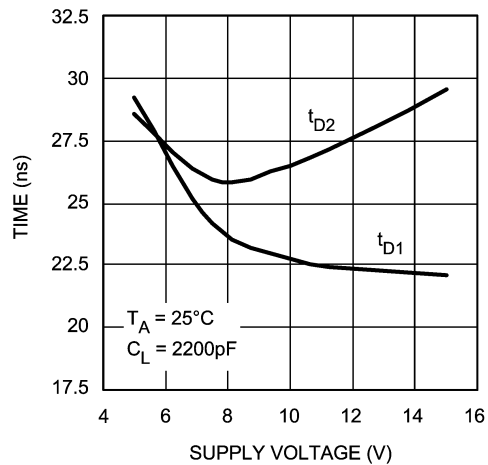

20066812

Typical Performance Characteristics (Continued)

Delay Time vs Temperature

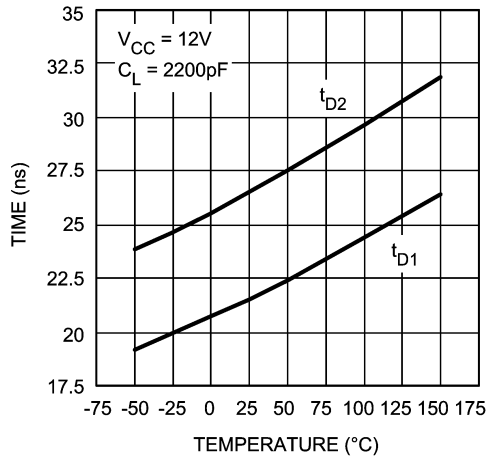

20066813

RDSON vs Supply Voltage

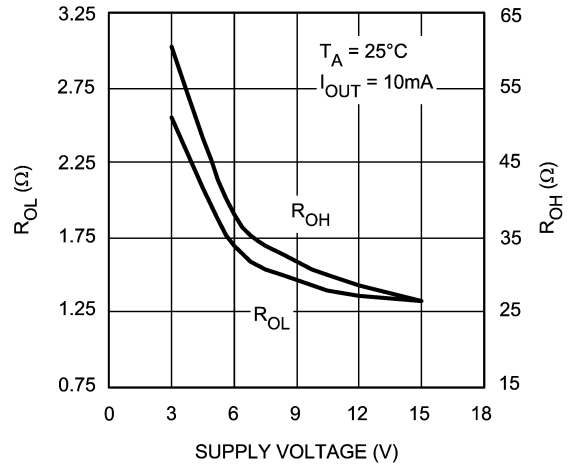

20066814

UVLO Thresholds and Hysteresis vs Temperature

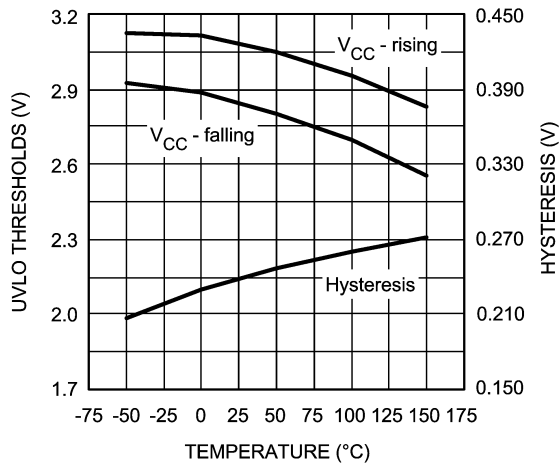

20066815

Peak Current vs Supply Voltage

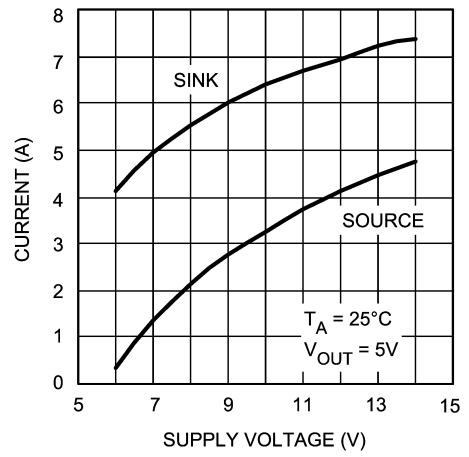

20066816

## Simplified Application Block Diagram

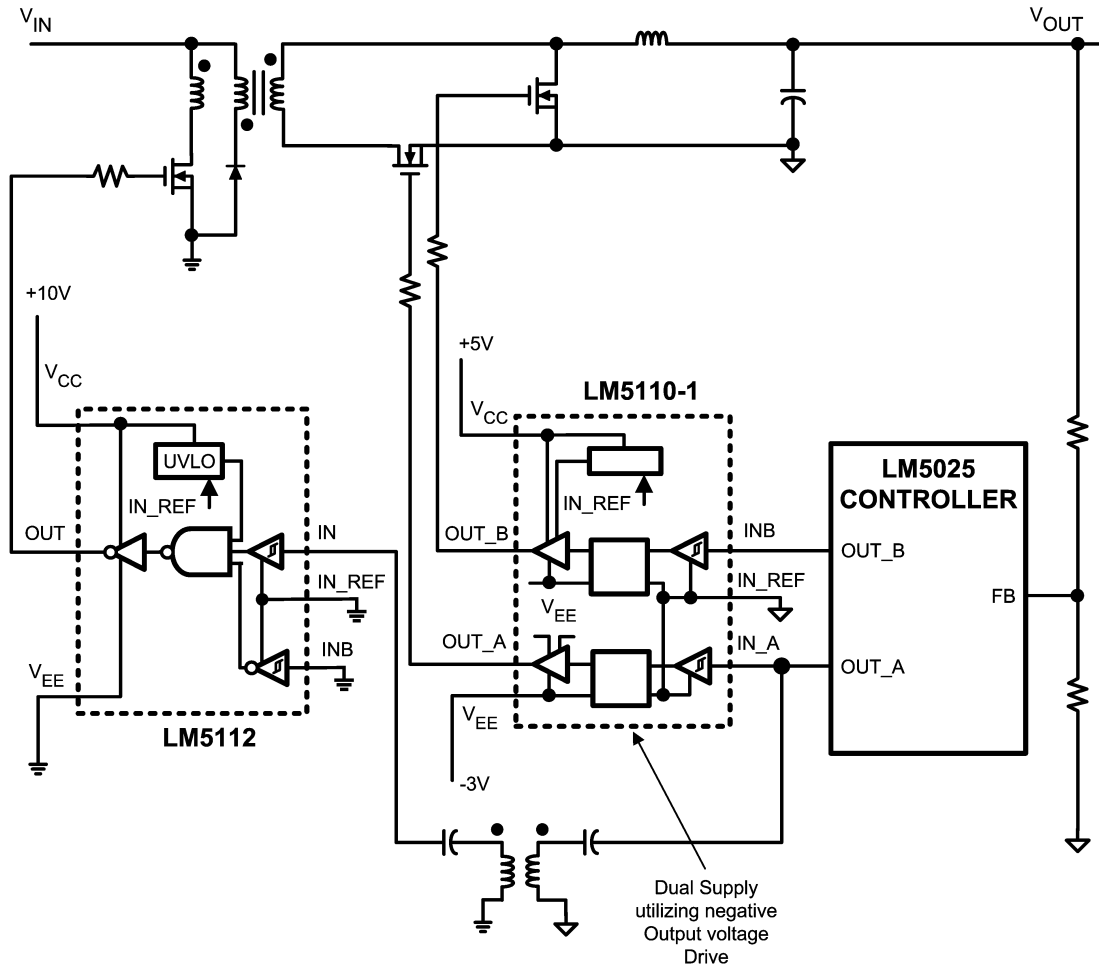

20066803

FIGURE 2. Simplified Application Block Diagram

## Detailed Operating Description

The LM5112 is a high speed, high peak current (7A) single channel MOSFET driver. The high peak output current of the LM5112 will switch power MOSFET's on and off with short rise and fall times, thereby reducing switching losses considerably. The LM5112 includes both inverting and non-inverting inputs that give the user flexibility to drive the MOSFET with either active low or active high logic signals. The driver output stage consists of a compound structure with MOS and bipolar transistor operating in parallel to optimize current capability over a wide output voltage and operating temperature range. The bipolar device provides high peak current at the critical Miller plateau region of the MOSFET  $V_{GS}$ , while the MOS device provides rail-to-rail output swing. The totem pole output drives the MOSFET gate between the gate drive supply voltage  $V_{CC}$  and the power ground potential at the  $V_{EE}$  pin.

The control inputs of the driver are high impedance CMOS buffers with TTL compatible threshold voltages. The negative supply of the input buffer is connected to the input ground pin  $IN\_REF$ . An internal level shifting circuit connects the logic input buffers to the totem pole output drivers. The level shift circuit and separate input/output ground pins pro-

vide the option of single supply or split supply configurations. When driving the MOSFET gates from a single positive supply, the  $IN\_REF$  and  $V_{EE}$  pins are both connected to the power ground.

The isolated input and output stage grounds provide the capability to drive the MOSFET to a negative  $V_{GS}$  voltage for a more robust and reliable off state. In split supply configuration, the  $IN\_REF$  pin is connected to the ground of the controller which drives the LM5112 inputs. The  $V_{EE}$  pin is connected to a negative bias supply that can range from the  $IN\_REF$  potential to as low as 14 V below the  $V_{CC}$  gate drive supply. For reliable operation, the maximum voltage difference between  $V_{CC}$  and  $IN\_REF$  or between  $V_{CC}$  and  $V_{EE}$  is 14V.

The minimum recommended operating voltage between  $V_{CC}$  and  $IN\_REF$  is 3.5V. An Under Voltage Lock Out (UVLO) circuit is included in the LM5112 which senses the voltage difference between  $V_{CC}$  and the input ground pin,  $IN\_REF$ . When the  $V_{CC}$  to  $IN\_REF$  voltage difference falls below 2.8V the driver is disabled and the output pin is held in the low state. The UVLO hysteresis prevents chattering during



## Detailed Operating Description

(Continued)

brown-out conditions; the driver will resume normal operation when the  $V_{CC}$  to  $IN\_REF$  differential voltage exceeds 3.0V.

### Layout Considerations

Attention must be given to board layout when using LM5112. Some important considerations include:

1. A Low ESR/ESL capacitor must be connected close to the IC and between the  $V_{CC}$  and  $V_{EE}$  pins to support high peak currents being drawn from  $V_{CC}$  during turn-on of the MOSFET.
2. Proper grounding is crucial. The driver needs a very low impedance path for current return to ground avoiding inductive loops. Two paths for returning current to ground are a) between LM5112  $IN\_REF$  pin and the ground of the circuit that controls the driver inputs and b) between LM5112  $V_{EE}$  pin and the source of the power MOSFET being driven. Both paths should be as short as possible to reduce inductance and be as wide as possible to reduce resistance. These ground paths should be distinctly separate to avoid coupling between the high current output paths and the logic signals that drive the LM5112. With rise and fall times in the range of 10 to 30nsec, care is required to minimize the lengths of current carrying conductors to reduce their inductance and EMI from the high di/dt transients generated when driving large capacitive loads.
3. If either channel is not being used, the respective input pin ( $IN$  or  $INB$ ) should be connected to either  $V_{EE}$  or  $V_{CC}$  to avoid spurious output signals.

## Thermal Performance

### INTRODUCTION

The primary goal of the thermal management is to maintain the integrated circuit (IC) junction temperature ( $T_j$ ) below a specified limit to ensure reliable long term operation. The maximum  $T_j$  of IC components should be estimated in worst case operating conditions. The junction temperature can be calculated based on the power dissipated on the IC and the junction to ambient thermal resistance  $\theta_{JA}$  for the IC package in the application board and environment. The  $\theta_{JA}$  is not a given constant for the package and depends on the PCB design and the operating environment.

### DRIVE POWER REQUIREMENT CALCULATIONS IN LM5112

LM5112 is a single low side MOSFET driver capable of sourcing / sinking 3A / 7A peak currents for short intervals to drive a MOSFET without exceeding package power dissipation limits. High peak currents are required to switch the MOSFET gate very quickly for operation at high frequencies.

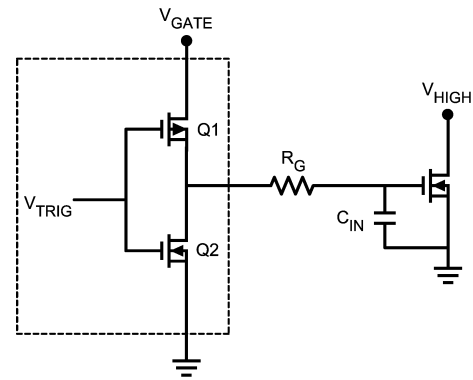

20066806

FIGURE 3.

The schematic above shows a conceptual diagram of the LM5112 output and MOSFET load. Q1 and Q2 are the switches within the gate driver.  $R_g$  is the gate resistance of the external MOSFET, and  $C_{in}$  is the equivalent gate capacitance of the MOSFET. The equivalent gate capacitance is a difficult parameter to measure as it is the combination of  $C_{gs}$  (gate to source capacitance) and  $C_{gd}$  (gate to drain capacitance). The  $C_{gd}$  is not a constant and varies with the drain voltage. The better way of quantifying gate capacitance is the gate charge  $Q_g$  in coulombs.  $Q_g$  combines the charge required by  $C_{gs}$  and  $C_{gd}$  for a given gate drive voltage  $V_{gate}$ . The gate resistance  $R_g$  is usually very small and losses in it can be neglected. The total power dissipated in the MOSFET driver due to gate charge is approximated by:

$$P_{DRIVER} = V_{GATE} \times Q_g \times F_{SW}$$

Where

$F_{SW}$  = switching frequency of the MOSFET.

For example, consider the MOSFET MTD6N15 whose gate charge specified as 30 nC for  $V_{GATE} = 12V$ .

Therefore, the power dissipation in the driver due to charging and discharging of MOSFET gate capacitances at switching frequency of 300 kHz and  $V_{GATE}$  of 12V is equal to

$$P_{DRIVER} = 12V \times 30 \text{ nC} \times 300 \text{ kHz} = 0.108W.$$

In addition to the above gate charge power dissipation, - transient power is dissipated in the driver during output transitions. When either output of the LM5112 changes state, current will flow from  $V_{CC}$  to  $V_{EE}$  for a very brief interval of time through the output totem-pole N and P channel MOSFETs. The final component of power dissipation in the driver is the power associated with the quiescent bias current consumed by the driver input stage and Under-voltage lockout sections.

Characterization of the LM5112 provides accurate estimates of the transient and quiescent power dissipation components. At 300 kHz switching frequency and 30 nC load used in the example, the transient power will be 8 mW. The 1 mA nominal quiescent current and 12V  $V_{GATE}$  supply produce a 12 mW typical quiescent power.

Therefore the total power dissipation

$$P_D = 0.118 + 0.008 + 0.012 = 0.138W.$$

We know that the junction temperature is given by

$$T_J = P_D \times \theta_{JA} + T_A$$

Or the rise in temperature is given by

$$T_{RISE} = T_J - T_A = P_D \times \theta_{JA}$$

## Thermal Performance (Continued)

For LLP-6 package, the integrated circuit die is attached to leadframe die pad which is soldered directly to the printed circuit board. This substantially decreases the junction to ambient thermal resistance ( $\theta_{JA}$ ). By providing suitable means of heat dispersion from the IC to the ambient through exposed copper pad, which can readily dissipate heat to the

surroundings,  $\theta_{JA}$  as low as  $40^{\circ}\text{C} / \text{Watt}$  is achievable with the package. The resulting  $T_{RISE}$  for the driver example above is thereby reduced to just 5.5 degrees.

Therefore  $T_{RISE}$  is equal to

$$T_{RISE} = 0.138 \times 40 = 5.5^{\circ}\text{C}$$

For MSOP8-EP  $\theta_{JA}$  is typically  $60^{\circ}\text{C/W}$ .

**Physical Dimensions** inches (millimeters) unless otherwise noted

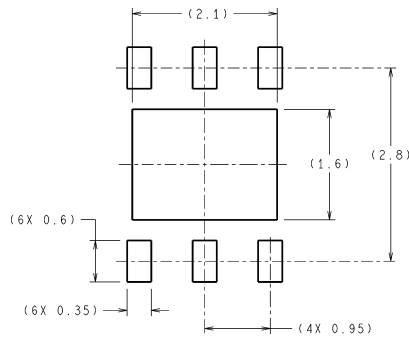

RECOMMENDED LAND PATTERN

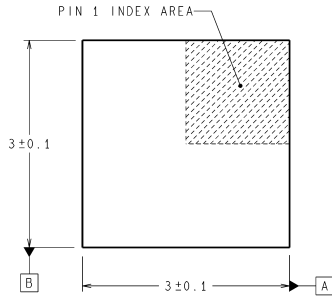

DIMENSIONS ARE IN MILLIMETERS  
DIMENSION IN ( ) FOR REFERENCE ONLY

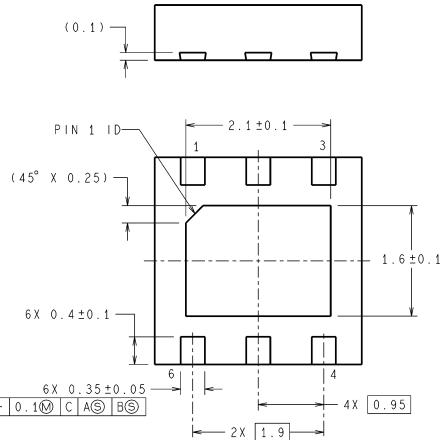
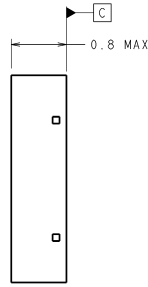

SDE06A (Rev A)

**6-Lead LLP Package**  
**NS Package Number SDE06A**

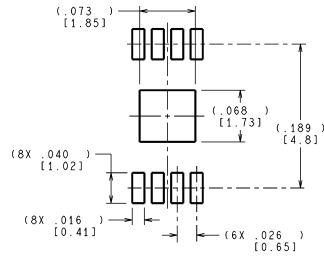
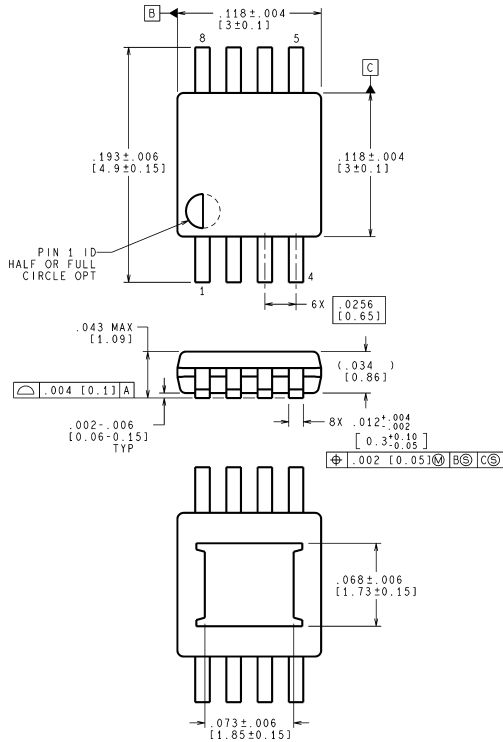

RECOMMENDED LAND PATTERN

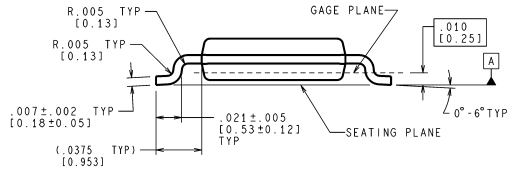

CONTROLLING DIMENSION IS INCH  
VALUES IN [ ] ARE MILLIMETERS

MUY08A (Rev A)

**8-Lead eMSOP-8 Package**  
**NS Package Number MUY08A**

## Notes

National does not assume any responsibility for use of any circuitry described, no circuit patent licenses are implied and National reserves the right at any time without notice to change said circuitry and specifications.

For the most current product information visit us at [www.national.com](http://www.national.com).

### LIFE SUPPORT POLICY

NATIONAL'S PRODUCTS ARE NOT AUTHORIZED FOR USE AS CRITICAL COMPONENTS IN LIFE SUPPORT DEVICES OR SYSTEMS WITHOUT THE EXPRESS WRITTEN APPROVAL OF THE PRESIDENT AND GENERAL COUNSEL OF NATIONAL SEMICONDUCTOR CORPORATION. As used herein:

- |  |   |
|--|---|
| <p>1. Life support devices or systems are devices or systems which, (a) are intended for surgical implant into the body, or (b) support or sustain life, and whose failure to perform when properly used in accordance with instructions for use provided in the labeling, can be reasonably expected to result in a significant injury to the user.</p> | <p>2. A critical component is any component of a life support device or system whose failure to perform can be reasonably expected to cause the failure of the life support device or system, or to affect its safety or effectiveness.</p> |
|--|---|

### BANNED SUBSTANCE COMPLIANCE

National Semiconductor manufactures products and uses packing materials that meet the provisions of the Customer Products Stewardship Specification (CSP-9-111C2) and the Banned Substances and Materials of Interest Specification (CSP-9-111S2) and contain no "Banned Substances" as defined in CSP-9-111S2.

Leadfree products are RoHS compliant.



**National Semiconductor**  
**Americas Customer**  
**Support Center**  
 Email: [new.feedback@nsc.com](mailto:new.feedback@nsc.com)  
 Tel: 1-800-272-9959

**National Semiconductor**  
**Europe Customer Support Center**  
 Fax: +49 (0) 180-530 85 86  
 Email: [europe.support@nsc.com](mailto:europe.support@nsc.com)  
 Deutsch Tel: +49 (0) 69 9508 6208  
 English Tel: +44 (0) 870 24 0 2171  
 Français Tel: +33 (0) 1 41 91 8790

**National Semiconductor**  
**Asia Pacific Customer**  
**Support Center**  
 Email: [ap.support@nsc.com](mailto:ap.support@nsc.com)

**National Semiconductor**  
**Japan Customer Support Center**  
 Fax: 81-3-5639-7507  
 Email: [jpn.feedback@nsc.com](mailto:jpn.feedback@nsc.com)  
 Tel: 81-3-5639-7560

## IMPORTANT NOTICE

Texas Instruments Incorporated and its subsidiaries (TI) reserve the right to make corrections, modifications, enhancements, improvements, and other changes to its products and services at any time and to discontinue any product or service without notice. Customers should obtain the latest relevant information before placing orders and should verify that such information is current and complete. All products are sold subject to TI's terms and conditions of sale supplied at the time of order acknowledgment.

TI warrants performance of its hardware products to the specifications applicable at the time of sale in accordance with TI's standard warranty. Testing and other quality control techniques are used to the extent TI deems necessary to support this warranty. Except where mandated by government requirements, testing of all parameters of each product is not necessarily performed.

TI assumes no liability for applications assistance or customer product design. Customers are responsible for their products and applications using TI components. To minimize the risks associated with customer products and applications, customers should provide adequate design and operating safeguards.

TI does not warrant or represent that any license, either express or implied, is granted under any TI patent right, copyright, mask work right, or other TI intellectual property right relating to any combination, machine, or process in which TI products or services are used. Information published by TI regarding third-party products or services does not constitute a license from TI to use such products or services or a warranty or endorsement thereof. Use of such information may require a license from a third party under the patents or other intellectual property of the third party, or a license from TI under the patents or other intellectual property of TI.

Reproduction of TI information in TI data books or data sheets is permissible only if reproduction is without alteration and is accompanied by all associated warranties, conditions, limitations, and notices. Reproduction of this information with alteration is an unfair and deceptive business practice. TI is not responsible or liable for such altered documentation. Information of third parties may be subject to additional restrictions.

Resale of TI products or services with statements different from or beyond the parameters stated by TI for that product or service voids all express and any implied warranties for the associated TI product or service and is an unfair and deceptive business practice. TI is not responsible or liable for any such statements.

TI products are not authorized for use in safety-critical applications (such as life support) where a failure of the TI product would reasonably be expected to cause severe personal injury or death, unless officers of the parties have executed an agreement specifically governing such use. Buyers represent that they have all necessary expertise in the safety and regulatory ramifications of their applications, and acknowledge and agree that they are solely responsible for all legal, regulatory and safety-related requirements concerning their products and any use of TI products in such safety-critical applications, notwithstanding any applications-related information or support that may be provided by TI. Further, Buyers must fully indemnify TI and its representatives against any damages arising out of the use of TI products in such safety-critical applications.

TI products are neither designed nor intended for use in military/aerospace applications or environments unless the TI products are specifically designated by TI as military-grade or "enhanced plastic." Only products designated by TI as military-grade meet military specifications. Buyers acknowledge and agree that any such use of TI products which TI has not designated as military-grade is solely at the Buyer's risk, and that they are solely responsible for compliance with all legal and regulatory requirements in connection with such use.

TI products are neither designed nor intended for use in automotive applications or environments unless the specific TI products are designated by TI as compliant with ISO/TS 16949 requirements. Buyers acknowledge and agree that, if they use any non-designated products in automotive applications, TI will not be responsible for any failure to meet such requirements.

Following are URLs where you can obtain information on other Texas Instruments products and application solutions:

### Products

Audio	<a href="http://www.ti.com/audio">www.ti.com/audio</a>
Amplifiers	<a href="http://amplifier.ti.com">amplifier.ti.com</a>
Data Converters	<a href="http://dataconverter.ti.com">dataconverter.ti.com</a>
DLP® Products	<a href="http://www.dlp.com">www.dlp.com</a>
DSP	<a href="http://dsp.ti.com">dsp.ti.com</a>
Clocks and Timers	<a href="http://www.ti.com/clocks">www.ti.com/clocks</a>
Interface	<a href="http://interface.ti.com">interface.ti.com</a>
Logic	<a href="http://logic.ti.com">logic.ti.com</a>
Power Mgmt	<a href="http://power.ti.com">power.ti.com</a>
Microcontrollers	<a href="http://microcontroller.ti.com">microcontroller.ti.com</a>
RFID	<a href="http://www.ti-rfid.com">www.ti-rfid.com</a>
OMAP Mobile Processors	<a href="http://www.ti.com/omap">www.ti.com/omap</a>
Wireless Connectivity	<a href="http://www.ti.com/wirelessconnectivity">www.ti.com/wirelessconnectivity</a>

### Applications

Communications and Telecom	<a href="http://www.ti.com/communications">www.ti.com/communications</a>
Computers and Peripherals	<a href="http://www.ti.com/computers">www.ti.com/computers</a>
Consumer Electronics	<a href="http://www.ti.com/consumer-apps">www.ti.com/consumer-apps</a>
Energy and Lighting	<a href="http://www.ti.com/energy">www.ti.com/energy</a>
Industrial	<a href="http://www.ti.com/industrial">www.ti.com/industrial</a>
Medical	<a href="http://www.ti.com/medical">www.ti.com/medical</a>
Security	<a href="http://www.ti.com/security">www.ti.com/security</a>
Space, Avionics and Defense	<a href="http://www.ti.com/space-avionics-defense">www.ti.com/space-avionics-defense</a>
Transportation and Automotive	<a href="http://www.ti.com/automotive">www.ti.com/automotive</a>
Video and Imaging	<a href="http://www.ti.com/video">www.ti.com/video</a>

TI E2E Community Home Page

[e2e.ti.com](http://e2e.ti.com)

Mailing Address: Texas Instruments, Post Office Box 655303, Dallas, Texas 75265  
Copyright © 2011, Texas Instruments Incorporated