

**MNLM138-X REV 1A0**

 Original Creation Date: 07/12/95  
 Last Update Date: 08/13/01  
 Last Major Revision Date: 08/02/01

## 5 AMP ADJUSTABLE POWER REGULATOR

### General Description

The LM138 series of adjustable 3-terminal positive voltage regulators is capable of supplying in excess of 5A over a 1.2V to 32V output range. They are exceptionally easy to use and require only 2 resistors to set the output voltage. Careful circuit design has resulted in outstanding load and line regulation-comparable to many commercial power supplies. The LM138 family is supplied in a standard 3-lead transistor package.

A unique feature of the LM138 family is time-dependent current limiting. The current limit circuitry allows peak currents of up to 12A to be drawn from the regulator for short periods of time. This allows the LM138 to be used with heavy transient loads and speeds start-up under full-load condition. Under sustained loading conditions, the current limit decreases to a safe value protecting the regulator. Also included on the chip are thermal overload protection and safe area protection for the power transistor. Overload protection remains functional even if the adjustment pin is accidentally disconnected.

Normally, no capacitors are needed unless the device is situated more than 6 inches from the input filter capacitors in which case an input bypass is needed. An output capacitor can be added to improve transient response, while bypassing the adjustment pin will increase the regulator's ripple rejection.

Besides replacing fixed regulators or discrete designs, the LM 138 is useful in a wide variety of other applications. Since the regulator is floating and sees only the input-to-output differential voltage, supplies of several hundred volts can be regulated as long as the maximum input to output differential voltage, is not exceeded.

### Industry Part Number

LM138

### NS Part Numbers

LM138K-MIL

### Prime Die

LM138

### Processing

MIL-STD-883, Method 5004

### Quality Conformance Inspection

MIL-STD-883, Method 5005

Subgrp	Description	Temp ( °C)
1	Static tests at	+25
2	Static tests at	+125
3	Static tests at	-55
4	Dynamic tests at	+25
5	Dynamic tests at	+125
6	Dynamic tests at	-55
7	Functional tests at	+25
8A	Functional tests at	+125
8B	Functional tests at	-55
9	Switching tests at	+25
10	Switching tests at	+125
11	Switching tests at	-55

**(Absolute Maximum Ratings)**

(Note 1)

Power Dissipation	Internally limited
Storage Temperature	-65 C to +150 C
Lead Temperature (Soldering, 10 Sec.)	300 C
Maximum Junction Temperature	150 C
Input/Output Differential	+40V, -0.3V
Thermal Resistance	
ThetaJA	
Still Air	40 C
500LF/Min Air Flow	TBD
ThetaJC	TBD
Package Weight (Typical)	TBD
ESD Tolerance (Note 3)	TBD

Note 1: Absolute Maximum Rating indicate limits beyond which damage to the device may occur. Operating Ratings indicate conditions for which the device is functional, but do not guarantee specific performance limits. For guaranteed specifications and test conditions, see the Electrical Characteristics. The guaranteed specifications apply only for the test conditions listed. Some performance characteristics may degrade when the device is not operated under the listed test conditions.

Note 2: The maximum power dissipation must be derated at elevated temperatures and is dictated by Tjmax (maximum junction temperature), ThetaJA (package junction to ambient thermal resistance), and TA (ambient temperature). The maximum allowable power dissipation at any temperature is  $P_{dmax} = (T_{jmax} - TA)/\Theta_{JA}$  or the number given in the Absolute Maximum Ratings, whichever is lower.

Note 3: Human body model, 1.5K ohms in series with 100pF

## Electrical Characteristics

### DC PARAMETERS

(The following conditions apply to all the following parameters, unless otherwise specified.)  
DC:  $V_{diff}=5V$ ,  $I_l=10mA$

SYMBOL	PARAMETER	CONDITIONS	NOTES	PIN-NAME	MIN	MAX	UNIT	SUB-GROUPS
Rline	Line Regulation	$3V \leq V_{diff} \leq 35V$			-3.5	3.5	mV	1
		$3.3V \leq V_{diff} \leq 35V$			-14	14	mV	2, 3
Rload	Load Regulation	$V_{diff}=3V$ , $10mA \leq I_l \leq 5A$ , $V_{out}=V_{ref}$			-3.8	3.8	mV	1
		$V_{diff}=3.3V$ , $10mA \leq I_l \leq 5A$ , $V_{out}=V_{ref}$			-8	8	mV	2, 3
		$V_{diff}=35V$ , $10mA \leq I_l \leq 150mA$ , $V_{out}=V_{ref}$			-3.8	3.8	mV	1
					-8	8	mV	2, 3
Vrth	Thermal Regulation	$V_{diff}=10V$ , Pulse=20mS, $I_l=1A$	1			0.01	%/Wat t	1
Iadj	Adjustment Pin Current	$V_{diff}=3V$	2		2	100	uA	1, 2, 3
		$V_{diff}=35V$			2	100	uA	1, 2, 3
Delta Iadj	Adjustment Pin Current Change	$3V \leq V_{diff} \leq 35V$	2		-5	5	uA	1, 2, 3
		$10mA \leq I_l \leq 5A$			-5	5	uA	1, 2, 3
I <sub>lmin</sub>	Min Load Current	$V_{diff}=3V$ , $V_{out}=1.4V$	2		0.5	5	mA	1, 2, 3
		$V_{diff}=35V$ , $V_{out}=1.4V$			0.5	5	mA	1, 2, 3
V <sub>ref</sub>	Reference Voltage	$V_{diff}=3V$	2		1.19	1.29	V	1, 2, 3
		$V_{diff}=3V$ , $I_l=5A$			1.19	1.29	V	1, 2, 3
		$V_{diff}=5V$ , $I_l=7A$			1.19	1.29	V	1, 2, 3
		$V_{diff}=35V$			1.19	1.29	V	1, 2, 3
		$V_{diff}=35V$ , $I_l=150mA$			1.19	1.29	V	1, 2, 3
I <sub>cl</sub>	Current Limit	$V_{diff}=10V$ , $T=0.5mS$ , $V_{out}=0V$			7	16	A	1, 2, 3
		$T=5.0mS$ , $V_{out}=0V$			5	15	A	1, 2, 3

## Electrical Characteristics

### AC PARAMETERS

(The following conditions apply to all the following parameters, unless otherwise specified.)  
DC:  $V_{diff}=5V$ ,  $I_l=10mA$

SYMBOL	PARAMETER	CONDITIONS	NOTES	PIN-NAME	MIN	MAX	UNIT	SUB-GROUPS
Rr	Ripple Rejection Ratio	$V_{out}=V_{ref}$ , $e_{in}=1V_{rms}$ , $f=120Hz$ , $I_l=500mA$	3		60		dB	4

Note 1: Datalog reading in mV,  $0.01\% = 1.19mV$ .

Note 2:  $V_{diff} = 3.3V$  at 125 C and -55 C.

Note 3: Family Board not required for this device.

## Graphics and Diagrams

GRAPHICS#	DESCRIPTION
05102HRD3	METAL CAN TO-3, 2LD, LOW PROFILE (B/I CKT)
K02CRE	METAL CAN TO-3, 2LD, LOW PROFILE (P/P DWG)
P000322A	METAL CAN TO-3, 2LD, LOW PROFILE (PINOUT)

See attached graphics following this page.

REVISIONS			
LTR	DESCRIPTION	E.C.N.	DATE
E	REDRAW ON PROFILE: UPDATE MIL/AERO STAMP: NOTE 2: MIL-PRF-38535 WAS MIL-I-38535.	11155	09/15/95 MS/

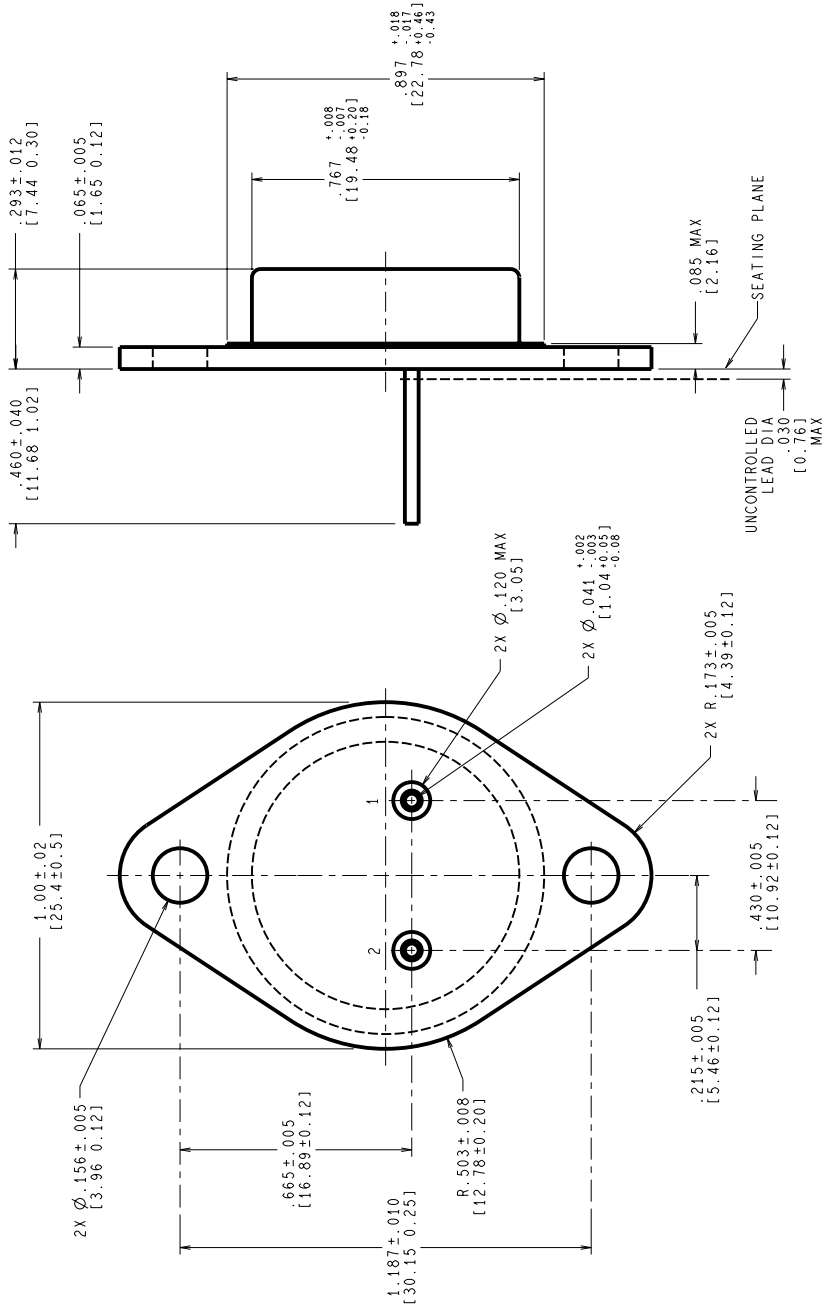

CONTROLLING DIMENSION IS INCH  
VALUES IN [ ] ARE MILLIMETERS

MIL-PRF-38535  
CONFIGURATION CONTROL

NOTES: UNLESS OTHERWISE SPECIFIED

1. STANDARD HEADER TYPE SOLID BASE.
2. STANDARD LEAD FINISH:  
PER MIL-PRF-38535 TYPE X OR EQUIVALENT.
3. LEAD NOT BENT GREATER THAN 15°.
4. DIMENSIONS BASED ON JEDEC STANDARD TO-3,  
PUBLICATION 95, PAGE 98.

APPROVALS		DATE
DRNWR	MARTA SUCHY	09/15/95
DRG. CHK.		
ENGR. CHK.		

		<b>National Semiconductor</b> 2800 Semiconductor Dr., Santa Clara, CA 95052-8090	
METAL CAN, TO-3, 2 LEAD, LOW PROFILE		SCALE	DRAWING NUMBER
N/A	C	MKT-K02C	REV
DO NOT SCALE DRAWING		SHEET 1 of 1	

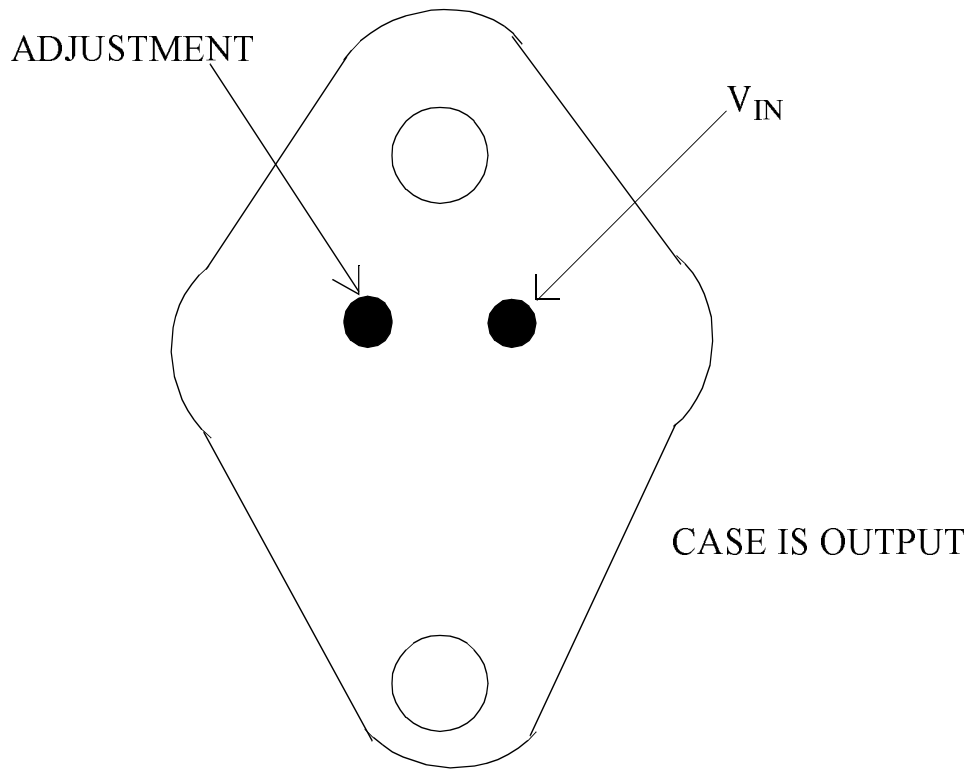

LM138K  
2 - LEAD TO-3  
CONNECTION DIAGRAM  
BOTTOM VIEW  
P000322A



National Semiconductor™  
MIL/AEROSPACE OPERATIONS  
2900 SEMICONDUCTOR DRIVE  
SANTA CLARA, CA 95050