

# LM301A, LM201A, LM201AV

## Non Compensated Single Operational Amplifiers

A general purpose operational amplifier that allows the user to choose the compensation capacitor best suited to his needs. With proper compensation, summing amplifier slew rates to 10 V/ $\mu$ s can be obtained.

### Features

- Low Input Offset Current: 20 nA Maximum Over Temperature Range
- External Frequency Compensation for Flexibility
- Class AB Output Provides Excellent Linearity
- Output Short Circuit Protection
- Guaranteed Drift Characteristics
- Pb-Free Packages are Available

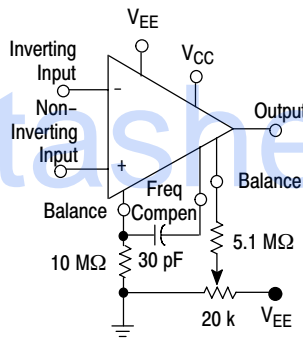

Figure 1. Standard Compensation and Offset Balancing Circuit

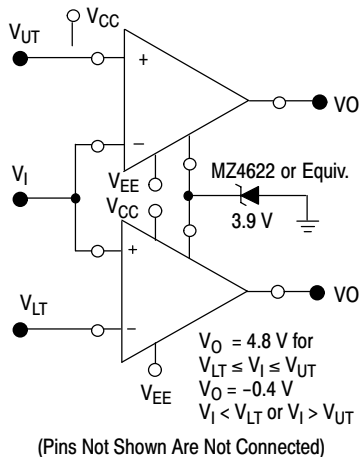
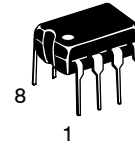

Figure 2. Double-Ended Limit Detector



ON Semiconductor®

<http://onsemi.com>



PDIP-8  
N SUFFIX  
CASE 626



SOIC-8  
D SUFFIX  
CASE 751

Datasheet.Directory

### PIN CONNECTIONS

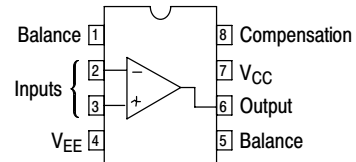

(Top View)

### ORDERING INFORMATION

See detailed ordering and shipping information in the package dimensions section on page 29 of this data sheet.

\*For additional information on our Pb-Free strategy and soldering details, please download the ON Semiconductor Soldering and Mounting Techniques Reference Manual, SOLDERRM/D.

### DEVICE MARKING INFORMATION

See general marking information in the device marking section on page 30 of this data sheet.

# LM301A, LM201A, LM201AV

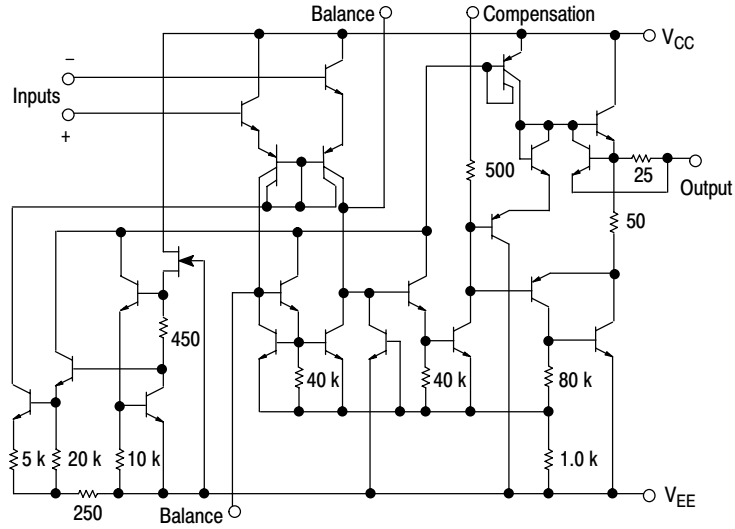

**Figure 3. Representative Circuit Schematic**

## ORDERING INFORMATION

Device	Package	Shipping <sup>†</sup>
LM301AD	SOIC-8	98 Units/Rail
LM301ADG	SOIC-8 (Pb-Free)	
LM301ADR2	SOIC-8	
LM301ADR2G	SOIC-8 (Pb-Free)	2500 Tape & Reel
LM301AN	PDIP-8	50 Units/Rail
LM201AD	SOIC-8	98 Units/Rail
LM201ADR2	SOIC-8	2500 Tape & Reel
LM201AN	PDIP-8	50 Units/Rail
LM201AVDR2	SOIC-8	2500 Tape & Reel

<sup>†</sup>For information on tape and reel specifications, including part orientation and tape sizes, please refer to our Tape and Reel Packaging Specifications Brochure, BRD8011/D.

# LM301A, LM201A, LM201AV

## MARKING DIAGRAMS

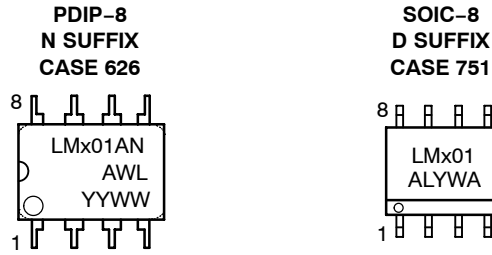

x = 2 or 3  
 A = Assembly Location  
 WL, L = Wafer Lot  
 YY, Y = Year  
 WW, W = Work Week

## MAXIMUM RATINGS

Rating	Symbol	Value			Unit
		LM201A	LM201AV	LM301A	
Power Supply Voltage	$V_{CC}, V_{EE}$	±22	±22	±18	Vdc
Input Differential Voltage	$V_{ID}$	← ±30 →			V
Input Common Mode Range (Note 1)	$V_{ICR}$	← ±15 →			V
Output Short Circuit Duration	$t_{SC}$	← Continuous →			
Power Dissipation (Package Limitation) Plastic Dual-In-Line Package Derate above $T_A = +25^\circ\text{C}$	$P_D$	625 5.0	625 5.0	625 5.0	mW mW/°C
Operating Ambient Temperature Range	$T_A$	-25 to +85	-40 to +105	0 to +70	°C
Storage Temperature Range	$T_{stg}$	← -65 to +150 →			°C

Maximum ratings are those values beyond which device damage can occur. Maximum ratings applied to the device are individual stress limit values (not normal operating conditions) and are not valid simultaneously. If these limits are exceeded, device functional operation is not implied, damage may occur and reliability may be affected.

## LM301A, LM201A, LM201AV

**ELECTRICAL CHARACTERISTICS** ( $T_A = +25^\circ\text{C}$ , unless otherwise noted.) Unless otherwise specified, these specifications apply for supply voltages from  $\pm 5.0\text{ V}$  to  $\pm 20\text{ V}$  for the LM201A and LM201AV, and from  $\pm 5.0\text{ V}$  to  $\pm 15\text{ V}$  for the LM301A.

Characteristic	Symbol	LM201A / LM201AV			LM301A			Unit
		Min	Typ	Max	Min	Typ	Max	
Input Offset Voltage ( $R_S \leq 50\text{ k}\Omega$ )	$V_{IO}$	–	0.7	2.0	–	2.0	7.5	mV
Input Offset Current	$I_{IO}$	–	1.5	10	–	3.0	50	nA
Input Bias Current	$I_{IB}$	–	30	75	–	70	250	nA
Input Resistance	$r_i$	1.5	4.0	–	0.5	2.0	–	M $\Omega$
Supply Current $V_{CC}/V_{EE} = \pm 20\text{ V}$ $V_{CC}/V_{EE} = \pm 15\text{ V}$	$I_{CC}, I_{EE}$	–	1.8	3.0	–	–	–	mA
		–	–	–	–	1.8	3.0	
Large Signal Voltage Gain ( $V_{CC}/V_{EE} = \pm 15\text{ V}$ , $V_O = \pm 10\text{ V}$ , $R_L > 2.0\text{ k}\Omega$ )	$A_V$	50	160	–	25	160	–	V/mV

The following specifications apply over the operating temperature range.

Input Offset Voltage ( $R_S \leq 50\text{ k}\Omega$ )	$V_{IO}$	–	–	3.0	–	–	10	mV
Input Offset Current	$I_{IO}$	–	–	20	–	–	70	nA
Avg Temperature Coefficient of Input Offset Voltage (Note 2) $T_A(\text{min}) \leq T_A \leq T_A(\text{max})$	$\Delta V_{IO}/\Delta T$	–	3.0	15	–	6.0	30	$\mu\text{V}/^\circ\text{C}$
Avg Temperature Coefficient of Input Offset Current (Note 2) $+25^\circ\text{C} \leq T_A \leq T_A(\text{max})$ $T_A(\text{min}) \leq T_A \leq 25^\circ\text{C}$	$\Delta I_{IO}/\Delta T$	–	0.01	0.1	–	0.01	0.3	nA/ $^\circ\text{C}$
		–	0.02	0.2	–	0.02	0.6	
Input Bias Current	$I_{IB}$	–	–	100	–	–	300	nA
Large Signal Voltage Gain ( $V_{CC}/V_{EE} = \pm 15\text{ V}$ , $V_O = \pm 10\text{ V}$ , $R_L > 2.0\text{ k}\Omega$ )	$A_{VOL}$	25	–	–	15	–	–	V/mV
Input Voltage Range $V_{CC}/V_{EE} = \pm 20\text{ V}$ $V_{CC}/V_{EE} = \pm 15\text{ V}$	$V_{ICR}$	–15	–	+15	–	–	–	V
		–	–	–	–12	–	+12	
Common Mode Rejection ( $R_S \leq 50\text{ k}\Omega$ )	CMR	80	96	–	70	90	–	dB
Supply Voltage Rejection ( $R_S \leq 50\text{ k}\Omega$ )	PSR	80	96	–	70	96	–	dB
Output Voltage Swing ( $V_{CC}/V_{EE} = \pm 15\text{ V}$ , $R_L = \pm 10\text{ k}\Omega$ , $R_L > 2.0\text{ k}\Omega$ )	$V_O$	$\pm 12$ $\pm 10$	$\pm 14$ $\pm 13$	–	$\pm 12$ $\pm 10$	$\pm 14$ $\pm 13$	–	V
Supply Currents ( $T_A = T_A(\text{max})$ , $V_{CC}/V_{EE} = \pm 20\text{ V}$ )	$I_{CC}, I_{EE}$	–	1.2	2.5	–	–	–	mA

- For supply voltages less than  $\pm 15\text{ V}$ , the absolute maximum input voltage is equal to the supply voltage.
- Guaranteed by design.

# LM301A, LM201A, LM201AV

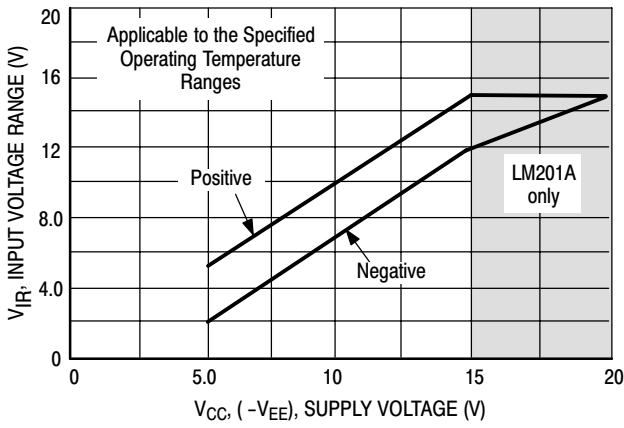

Figure 4. Minimum Input Voltage Range

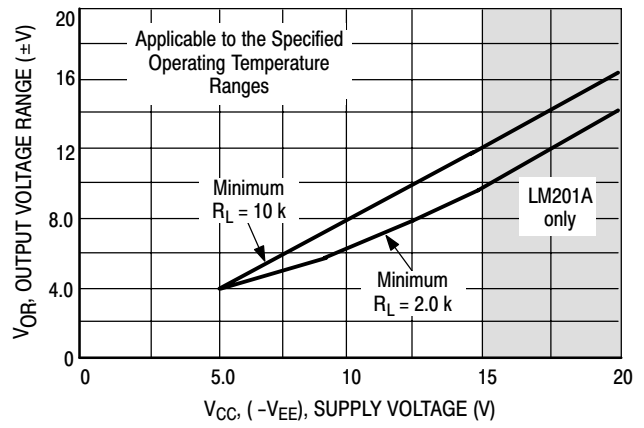

Figure 5. Minimum Output Voltage Swing

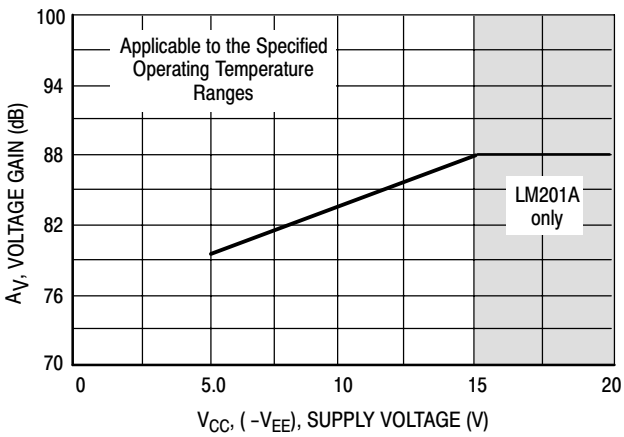

Figure 6. Minimum Voltage Gain

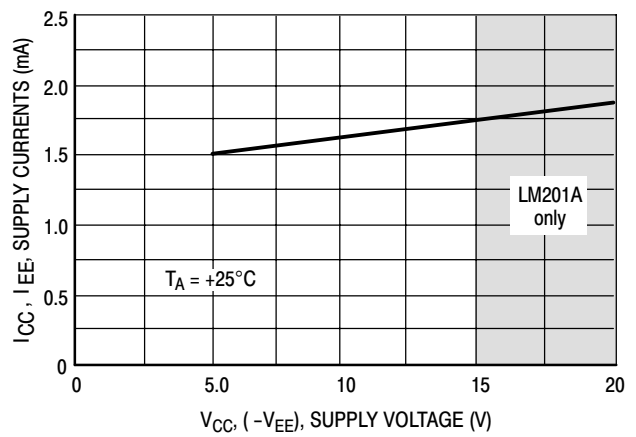

Figure 7. Typical Supply Currents

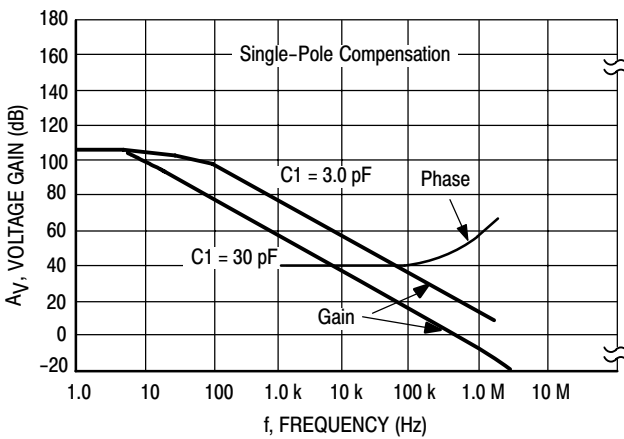

Figure 8. Open Loop Frequency Response

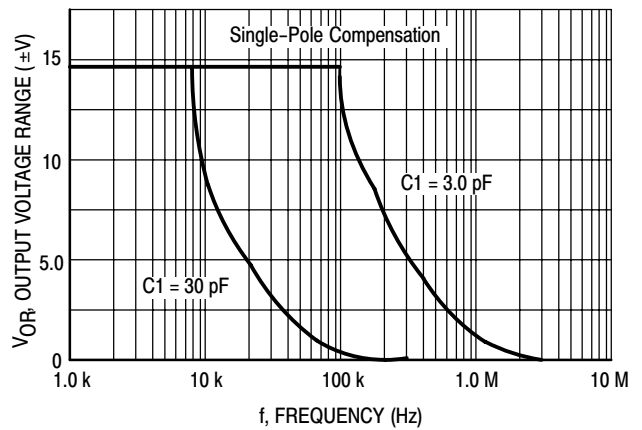

Figure 9. Large Signal Frequency Response

# LM301A, LM201A, LM201AV

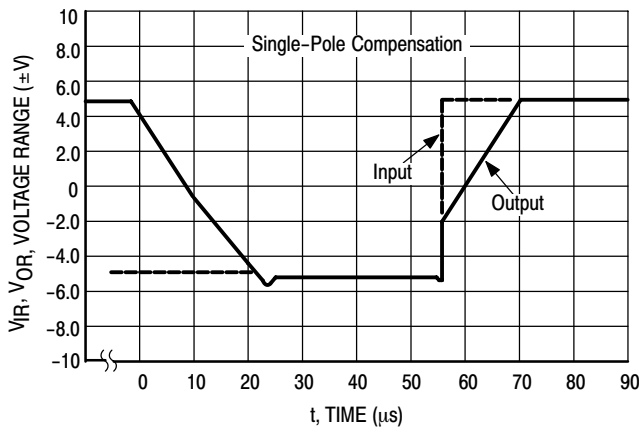

Figure 10. Voltage Follower Pulse Response

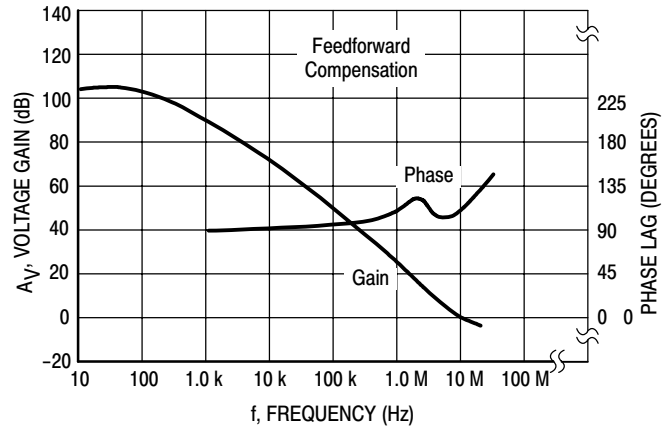

Figure 11. Open Loop Frequency Response

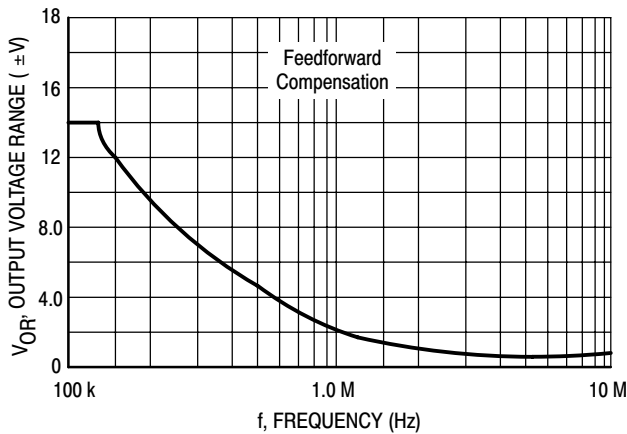

Figure 12. Large Signal Frequency Response

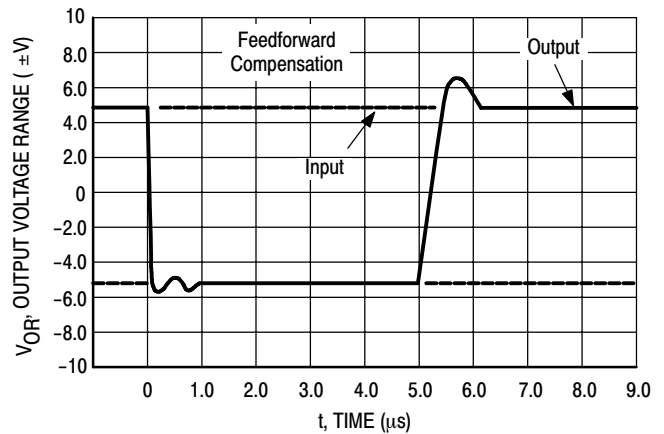

Figure 13. Inverter Pulse Response

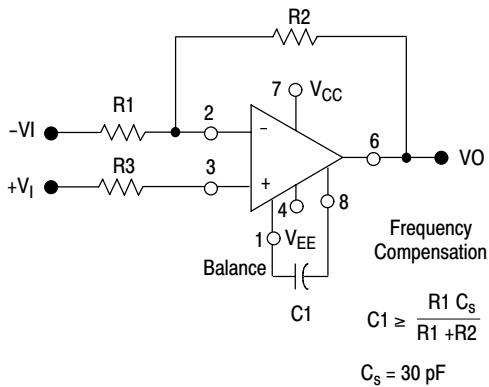

Figure 14. Single-Pole Compensation

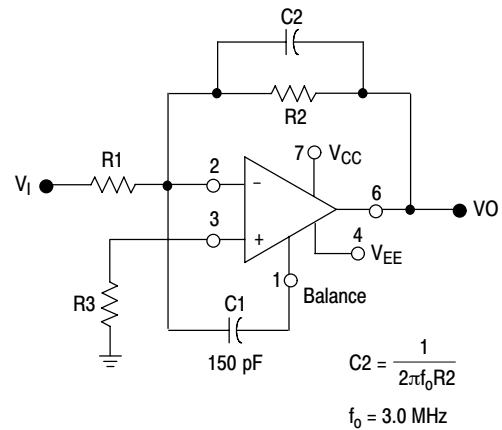

Figure 15. Feedforward Compensation