



November 1, 1996

RR-1J

Product Reliability Report

This report presents the product reliability data for Maxim's analog products. The data was acquired from extensive reliability stress testing performed in 1995. It is separated into seven fabrication processes: 1) Standard Metal-Gate CMOS (SMG); 2) Medium-Voltage Metal-Gate CMOS (MV1); 3) Medium-Voltage Silicon-Gate CMOS (MV2); 4) 3 μ m Silicon-Gate CMOS (SG3); 5) 5 μ m Silicon-Gate CMOS (SG5); 6) 1.2 μ m Silicon-Gate CMOS; and 7) Bipolar (BIP) processes.

Over 13,660,000 device hours have been accumulated for products stressed at an elevated temperature (135°C) during this period. The data in this report is considered typical of Maxim's production. As you will see, Maxim's products demonstrate consistently high reliability.



Product Reliability Report

RR-1J

Table of Contents

Fabrication Processes.....	3
Reliability Methodology.....	3
Reliability Program.....	3
Rel-Program Steps	3
Step 1: Initial Reliability Qualification Program	4
Step 2: Ongoing Reliability Monitor Program	4
Step 3: In-Depth Failure Analysis and Corrective Action	4
Designed-In High Reliability	4
Wafer Inspection	4
Failure-Rate History	5
Infant Mortality Evaluation and Product Burn-In	6
Reliability Data.....	6
Merits of Burn-In	6
Life Test at 135°C	6
Humidity Test	6
85/85 Test	7
Pressure Pot Test	7
HAST Test	7
Temperature Cycling Test	7
High-Temperature Storage Life Test	7
Hybrid Products Reliability Data.....	7
Process Variability Control.....	7
Process Technologies.....	8
Reliability Test Results.....	9
Appendix 1: Determining Acceleration Factor.....	21
Definition of Terms	21
How to Use the Arrhenius Equation	21
Appendix 2: Determining Failure Rate.....	22
Definition of Terms	22
Calculating Failure Rates and FITs	22
Including Statistical Effects in the FIT Calculation	22

Fabrication Processes

Maxim is currently running the following seven major fabrication processes:

- 1) SMG (Standard Metal-Gate CMOS)
- 2) MV1 (Medium-Voltage Metal-Gate CMOS)
- 3) MV2 (Medium-Voltage Silicon-Gate CMOS)
- 4) SG3 (3-Micron Silicon-Gate CMOS)
- 5) SG5 (5-Micron Silicon-Gate CMOS)
- 6) SG1.2 (1.2-Micron Silicon-Gate CMOS)
- 7) Bipolar (18/12-Micron)

SMG is a 6-micron, 24V, metal-gate CMOS process. It has conservative design rules, but is appropriate for many SSI and MSI circuit designs. This very popular fabrication process is used to produce many of Maxim's products.

MV1 is a 12-micron, 44V, metal-gate CMOS process, used exclusively to produce our analog switch product line.

MV2 is a 5-micron, 44V, silicon-gate CMOS process, also used in our analog switch production line.

SG3 is a 3-micron, 12V, silicon-gate CMOS process. SG5 is a 5-micron, 20V, silicon-gate CMOS process. SG1.2 is a 1.2-micron, 6V, silicon-gate CMOS process. SG3, SG5, and SG1.2 have become our future process standards.

Bipolar is an 18-micron, 44V or 12-micron, 24V bipolar process, used chiefly for precision references, op amps, and A/D converters.

Reliability Methodology

Maxim's quality approach to reliability testing is conservative. Each of the seven fabrication processes has been qualified using the following industry-standard tests: Life Test, 85/85, Pressure Pot, HAST, High-Temperature Storage Life, and Temperature Cycling. Each process has been qualified and proven to produce inherently high-quality product.

Maxim's early conservative approach included burn-in as a standard stage of our production flow. Burn-in ensured that our customers were receiving

a quality product. Now, with the addition of our own sophisticated fabrication facility, we have improved the innate product quality to the point where burn-in (BI) adds little reliability value.

Before removing BI from our standard products, we are undertaking an Infant Mortality analysis for each process. A process must demonstrate an inherent Infant Mortality failure rate of less than 300ppm. Table 4 shows the Infant Mortality evaluations undertaken. Each of the categories for failure is prioritized based on its relative frequency (Figure 3), to identify what area should be improved next. The data shown here demonstrates the positive direction of Maxim's quality standards. It illustrates our continued dedication to providing the lowest overall-cost solution to our customers, through superior quality products.

Maxim's SMG, MV1, MV2, SG3, SG5, SG1.2, and Bipolar processes clearly meet or exceed the performance and reliability expectations of the semiconductor industry. These processes are qualified for production.

Reliability Program

Maxim has implemented a series of Quality and Reliability programs aimed at building the highest quality, most reliable analog products in the industry.

Rel-Program Steps

All products, processes, packages, and changes in manufacturing steps must be subjected to Maxim's reliability testing before release to manufacturing for mass production. Our reliability program includes the following steps:

- Step 1: Initial Reliability Qualification Program
- Step 2: Ongoing Reliability Monitor Program
- Step 3: In-Depth Failure Analysis and Corrective Action

Tables 5–11 show the results of long-term Life Tests by process and device type. Tables 12–16 show the results of the 85/85, Pressure Pot, HAST, Temperature Cycling, and High-Temperature Storage Life tests, by device type. Tables 17 and 18 show hybrid product reliability.

Product Reliability Report

Step 1: Initial Reliability Qualification Program

Maxim's product reliability test program meets EIA-JEDEC standards and most standard OEM reliability test requirements.

Table 1 summarizes the qualification tests that are part of Maxim's reliability program. Before releasing products, we require that three consecutive manufacturing lots from a new process technology successfully meet the reliability test requirements.

TABLE 1. MAXIM RELIABILITY TEST PROGRAM

TEST NAME	CONDITIONS	SAMPLING PLAN ACC/SS
Life Test	+135°C/1000 hrs.	1/77
85/85	+85°C, 85% R.H. 1000 hrs. w/Bias	1/77
Pressure Pot	+121°C, 100% R.H. 2 ATM, 168 hrs.	0/77
Temperature Cycling	-65°C to +150°C Air to Air/1000 Cycling	1/77
High Temp. Storage Life	+150°C/1000 hrs.	1/77

Step 2: Ongoing Reliability Monitor Program

Each week Maxim identifies three wafer lots per process per fab to be the subjects of reliability monitor testing. Each lot is Pressure Pot tested, and tested to 192 hours of High-Temperature Life (at 135°C). On a quarterly basis, one wafer lot per process per fab is identified and subjected to the same long-term reliability tests as defined in Table 1. Test results are fed back into production.

Step 3: In-Depth Failure Analysis and Corrective Action

Our technical failure-analysis staff is capable of analyzing every reliability test failure to the device level. If an alarming reliability failure mechanism or trend is identified, the corrective action is initiated automatically. This proactive response and feedback ensures that discrepancies in any device failure mechanism are corrected before becoming major problems.

Designed-In High Reliability

A disciplined design methodology is an essential ingredient of manufacturing a reliable part. No amount of finished-product testing can create reliability in a marginal design.

To design-in reliability, Maxim began by formulating a set of physical layout rules that yield reliable products even under worst-case manufacturing tolerances. These rules are rigorously enforced, and every circuit is subjected to computerized Design Rule Checks (DRCs) to ensure compliance.

Special attention is paid to Electrostatic Discharge (ESD) protection. Maxim's goal is to design every pin of every product to withstand ESD voltages in excess of 2000V, through a unique protection structure. In the case of our RS-232 interface circuits, products can even withstand ± 15 kV ESD using the human-body model, ± 8 kV ESD using IEC1000-4-2 contact discharge, or ± 15 kV ESD using IEC1000-4-2 air-gap discharge. Maxim tests each new product for designed 50mA latchup protection.

Designs are extensively simulated (using both circuit and logic simulation software) to evaluate performance under worst-case conditions. Finally, every design is checked and rechecked by independent teams before being released to mask making.

Wafer Inspection

All wafers are fabricated using stable, proven processes with extremely tight control. Each wafer must pass numerous in-process checkpoints (such as oxide thickness, alignment, critical dimensions, and defect densities), and must comply with Maxim's demanding electrical and physical specifications.

Finished wafers are inspected optically to detect any physical defects. They are then parametrically tested to ensure full conformity to Maxim's specifications. Our parametric measurement system is designed to make the precision measurements that will ensure reliability and reproducibility in analog circuits.

We believe our quality-control technology is the best in the industry, capable of resolving current levels below 1pA, and of producing less than 1pF capacitance. Maxim's proprietary software allows automatic measurement of subthreshold characteristics, fast surface-state density, noise, and other parameters crucial to predicting long-term stability and reliability. Every Maxim wafer is subject to this rigorous screening at no premium to our customers.

Product Reliability Report

RR-1J

Failure-Rate History

The graph below (Figure 1) illustrates Maxim's Failures-in-Time (FIT) rate performance. It also highlights the progressive improvements made in

this FIT rate, a trend that we expect to see continue, thanks to our established continuous-improvement methodology.

FIGURE 1. MAXIM FIT RATES OVER TIME

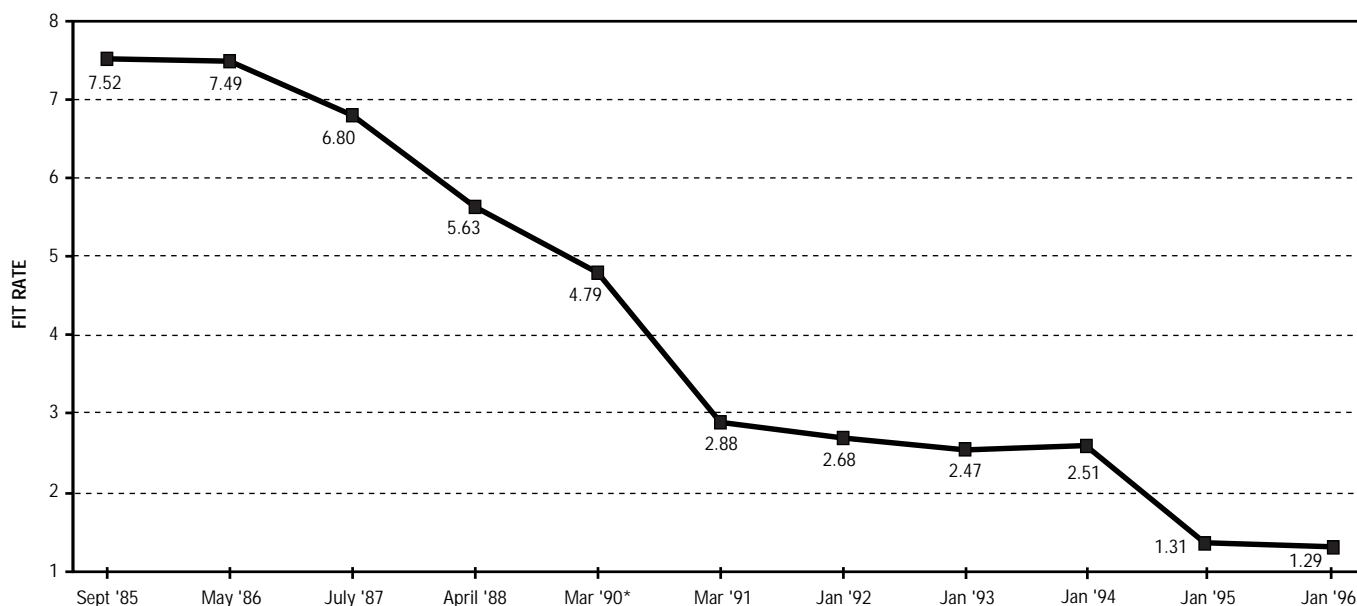

TABLE 2. LIFE TEST DATA

PRODUCT FAMILY	NUMBER OF LOTS	NUMBER OF FAILURES	TOTAL UNITS TESTED	DEGREE OF FREEDOM	X ² 60% VALUE	X ² 90% VALUE	FIT @ 25°C	
							60% CONF. LEVEL	90% CONF. LEVEL
CONVERTERS (Note 1)	85	12	6213	26	26.8	34.9	1.14	1.49
LINEAR (Note 2)	298	56	23,332	114	117	133	1.33	1.51
TIMERS/COUNTERS/ DISPLAY DRIVERS	8	3	640	8	7.96	12.6	3.30	5.21
SUM TOTAL OF ALL PRODUCT LOTS	391	71	30,185	144	147	165	1.29	1.45

Note 1: A/D Converters, D/A Converters

Note 2: Voltage References, Operational Amplifiers, Power-Supply Circuits, Interface, Filters, Analog Switches, and Multiplexers

Product Reliability Report

Infant Mortality Evaluation and Product Burn-In

Maxim evaluates each process and product family's Infant Mortality rate immediately after achieving qualified status. Through Infant Mortality analysis, we can identify the common defects for each process or product family. Our goal is to quantify the need for production burn-in. If a 300ppm level can be achieved, the product or process can be manufactured without production burn-in and still ensure an acceptable Infant Mortality rate. For an illustration of Maxim's low Infant Mortality rate, refer to Table 4.

Reliability Data

Merits of Burn-In

Figure 2 plots Failure Rate versus Time for the metal-gate CMOS process. The plot is based on Table 3's Life Test data and Table 4's Infant Mortality evaluation data, both applied to a General Reliability model. From this data, the benefit of production burn-in can be derived.

Table 3's data summarizes the reliability effect of production burn-in. Essentially, only eight units out of 13,360 were found to be outside the specification after 1000 hours of operation at 135°C. This is equal to an FIT rate of 0.16 at 25°C.

In comparison, the infant mortality rate is equal to 119 units out of 625,803 after 12 hours at 135°C, which has an equivalent FIT rate of approximately 0.806. In practical terms, 0.019%/six years (or 0.003%/year) of the total population would be found as defective through the first six years of operation, with an additional 0.011%/year failing over the remaining life of the product.

TABLE 3. LIFE TEST RESULT OF MAXIM PRODUCTS FOR EACH PROCESS
(Combined Test Conditions: 135°C and 1000 Hrs.)

PROCESS	SAMPLE SIZE	REJECTS	FIT@ 25°C	FIT@ 55°C
SMG	7614	4	0.16	2.70
MV1	378	0	0.55	9.49
MV2	306	0	0.68	11.72
SG3	3187	2	0.22	3.82
SG5	926	0	0.23	3.87
SG1.2	539	0	0.39	6.65
BIP	710	2	1.00	17.15
TOTAL	13,660	8	0.16	2.71

Life Test at 135 °C

Life Test is performed using biased conditions that simulate a real-world application. This test estimates the product's field performance. It establishes the constant failure-rate level and identifies any early wearout mechanisms. The tested product is kept in a controlled, elevated-temperature environment, typically at 135°C. This test can detect design, manufacturing, silicon, contamination, metal integrity, and assembly-related defects.

Test Used: High-Temperature Life and Dynamic Life Test (DLT)

Test Conditions: 135°C, 1000 hrs., inputs fed by clock drivers at 50% duty cycle

Failure Criteria: Must meet data sheet specifications

Results: See Tables 5–11

FIGURE 2. FAILURE RATE AT THE FIELD
(55°C for Metal-Gate CMOS Process)

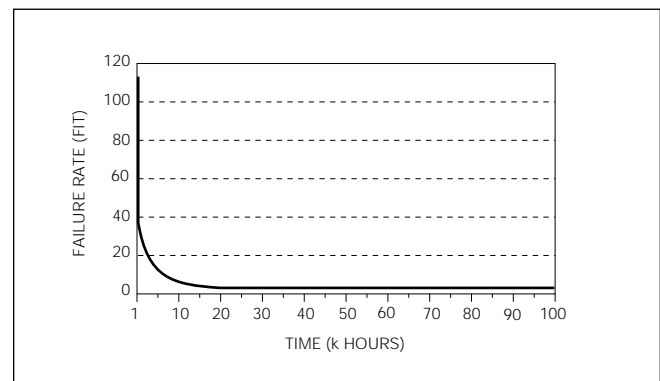

Humidity Test

The most popular integrated circuit (IC) packaging material is plastic. Plastic packages are not hermetic; therefore, moisture and other contaminants can enter the package. Humidity testing measures the contaminants present and the product's resistance to ambient conditions. Contaminants can be introduced during both wafer fabrication and assembly, and they can negatively affect product performance. Pressure Pot, 85/85, and HAST tests are used for this evaluation.

Product Reliability Report

RR-1J

85/85 Test

Maxim tests plastic-encapsulated products with an 85/85 test to determine the moisture resistance capability of our products under bias conditions. This test can detect the failure mechanisms found in Life Test. In addition, it can detect electrolytic and chemical corrosion.

Test Used: 85/85
Test Conditions: 85°C, 85% Relative Humidity, biased, 1000 hrs.
Failure Criteria: Must meet all data sheet parameters
Results: See Table 12

Pressure Pot Test

This test simulates a product's exposure to atmospheric humidity, which can be present during both wafer fabrication and assembly. Although an IC is covered with a nearly hermetic passivation layer (upper-surface coat), the bond pads must be exposed during bonding. Pressure Pot testing quickly determines if a potentially corrosive contaminant is present.

Test Used: Pressure Pot
Test Conditions: 121°C, 100% RH, no bias, 168 hrs.
Failure Criteria: Any opened bond or visual evidence of corrosion
Results: See Table 13

HAST Test

Highly Accelerated Steam and Temperature (HAST) testing is quickly replacing 85/85 testing. It serves the same basic function as 85/85 in typically 10% of the time, making HAST tests useful for immediate feedback and corrective action.

Test Used: HAST
Test Conditions: 120°C, 85% RH, biased, 100 hrs.
Failure Criteria: Must meet all data sheet specifications
Results: See Table 14

Temperature Cycling Test

This test measures a component's response to temperature changes and its construction quality. The test cycles parts through a predetermined temperature range (usually -65°C to +150°C). Both fabrication and assembly problems can be discovered using Temperature Cycling, but the test typically identifies assembly quality.

Test Used: Temperature Cycling
Test Conditions: -65°C to +150°C, 1000 cycles
Failure Criteria: Must meet all data sheet specifications
Results: See Table 15

High-Temperature Storage Life Test

This test evaluates changes in a product's performance after being stored for a set duration (1000 hrs.) at a high temperature (150°C). It is only useful for failure mechanisms accelerated by heat.

Test Used: High-Temperature Storage Life
Test Conditions: 150°C, 1000 hrs. unbiased
Failure Criteria: Must meet all data sheet specifications
Results: See Table 16

_____ Hybrid Products Reliability Data

Maxim's hybrid product reliability data is presented in Tables 17 and 18. Table 17 is the Life Test data for products tested in 1995. Table 18 is the Temperature Cycling test data for hybrid products.

_____ Process Variability Control

Reliability testing offers little value if the manufacturing process varies widely. A standard assumption, which is often false, is that test samples pulled from production are representative of the total population. Sample variability can be lessened by increasing the number of samples pulled. However, unless a process is kept "in control," major variations can invalidate reliability test results, leading to incorrect conclusions and diminishing the integrity of failure-rate estimates. Uncontrolled processes also make it difficult to prove failure rates of less than 10 FIT.

Maxim monitors the stability of critical process parameters through the use of computerized Statistical Process Control (SPC). Over 125 charts are monitored in-line during wafer production. Additionally, over 100 process parameters are monitored at Wafer Acceptance. Maxim has a target Capability Coefficient (Cpk) goal of 1.5, which is equivalent to 7ppm. In addition to SPC, Maxim uses Design of Experiments (DOE) to improve process capability, optimize process targeting, and increase robustness.

Product Reliability Report

Process Technologies

This section defines the layer-by-layer construction steps used in the fabrication of each process.

(1) SMG (Refer to Figure 4)

Layer	Description	Dimension
1	P-Well Diffusion	10 μ m
2	P+ Diffusion	2 μ m
3	N+ Diffusion	2 μ m
4	Gate-Oxide Growth	900Å
5	Threshold Implant	
6	Contact Etch	
7	Metallization	1 μ m (Al, Si-1%)
8	Passivation	0.8 μ m (Si ₃ N ₄ over SiO ₂)

(2) MV1 (Refer to Figure 5)

Layer	Description	Dimension
0	Buried Layer	10 μ m
1	EPI Deposit	19 μ m
2	P-Well Diffusion	10 μ m
3	P+ Diffusion	3 μ m
4	N+ Diffusion	3 μ m
5	Gate-Oxide Growth	1975Å
6	Threshold Implant	
7	Contact	
8	Metallization	1 μ m (Al, Si-1%)
9	Passivation	0.8 μ m (Si ₃ N ₄ over SiO ₂)

(3) MV2 (Refer to Figure 6)

Layer	Description	Dimension
1	Buried Layer	24.0 μ m
2	P Well	10.0 μ m
3	P+ Diffusion	1.5 μ m
4	N+ Diffusion	1.5 μ m
5	Gate-Oxide Growth	1000Å
6	P-Ch Threshold Adjust	
7	Polysilicon	4500Å
8	NLDD	
9	PLDD	
10	N+ Ohmic	
11	Contact	
12	Metal	1.0 μ m
13	Passivation	0.8 μ m

(4) SG3 (Refer to Figure 7)

Layer	Description	Dimension
1	P Well	6.0 μ m
2	PNP Base	
3	Zener Implant	
4	Active Area	1.5 μ m
5	P Guard	
6	N Guard	
7	P-Ch Threshold Adjust	
8	Poly 2	7000Å
9	Poly 1	4000Å
10	N+ Block	
11	P+ Select	
12	Thin Film	
13	CrSi Contact	
14	Contact	
15	Metal	1.0 μ m
16	Passivation	0.8 μ m (Si ₃ N ₄ over SiO ₂)

(5) SG5 (Refer to Figure 8)

Layer	Description	Dimension
1	P-Well Diffusion	8 μ m
2	PNP Base Drive	
3	Zener Implant	
4	Active Area/Field Ox	1 μ m
5	N Guard	
6	P Guard	
7	Threshold Adjust	
8	Gate-Oxide Growth	750Å
9	Polysilicon 1	4400Å
10	Cap Oxide	1000Å
11	Polysilicon 2	4400Å
12	N+ Implant (Source/Drain)	
13	P+ Implant (Source/Drain)	
14	Chrome/Si Thin-Film Deposit	
15	Contact	
16	Metallization	1 μ m
17	Passivation	0.8 μ m (Si ₃ N ₄ over SiO ₂)

(6) SG1.2 (Refer to Figure 9)

Layer	Description	Dimension
0	Mark Layer on P Substrate	
1	N+ Buried Layer	4 μ m
2	P+ Buried Layer	6 μ m
3	P Well	2.8 μ m
4	NPN Base	
5	PNP Base	
6	Active Area	
7	P Guard	
8	N Guard	
9	Gate-Oxide Growth	230Å
10	Poly 1	4200Å
11	Poly 2	4200Å
12	NMOS LDD	
13	N+ Implant (Source/Drain)	0.3 μ m
14	P+ Implant (Source/Drain)	0.3 μ m
15	Thin Film (Chrome/Si)	
16	Contact	
17	TF Contact	
18	Metal 1	6000Å
19	Metal 1 Options	
20	Via	
21	Metal 2	1.0 μ m
22	Passivation	8000Å

(7) BIP (Refer to Figure 10)

Layer	Description	Dimension
1	N+ Buried Layer	4.5 μ m
2	P+ Isolation	20 μ m
3	P Base	3 μ m
4	N+ Emitter	2.5 μ m
5	Capacitor	1500Å
6	Contact Etch	
7	Aluminum	11kÅ (Al, Si-1%)
8	Passivation	8kÅ (Si ₃ N ₄ over SiO ₂)

Product Reliability Report

Reliability Test Results

RR-1J

TABLE 4. INFANT MORTALITY EVALUATION RESULT

PRODUCT	LOT	BI TEMP (°C)	SS	FAILURES	PPM	ANALYSIS
MV1 PROCESS						
DG201ACJ	XRCAAB184C	135	11,698	1	85	1-MARGINAL LEAKAGE
DG211CJ	XRCAAB217Q	135	9642	4	414	4-MARGINAL LEAKAGE
DG212CJ	XRCBAA208Q	135	11,834	2	169	2-MARGINAL LEAKAGE
DG509ACJ	XROCAA045Q	135	12,629	11	871	7-IS _{OFF} CONTAMINATION, 1-HIGH I _{CC} , 3 TIMING
DG508ACJ	XROBAB029Q	135	10,216	2	195	1-ID _{ON} , ID _{OFF}
DG508ACJ	XROBAC030Q	135	<u>7912</u>	<u>0</u>	<u>0</u>	
SUBTOTAL			63,931	20	312.8	
MV2 PROCESS						
DG411DY	XRLADB016A	135	10,338	1	97	1-MARGINAL LEAKAGE
	XRLADB017B	135	10,482	0	0	
	XRLADB018B	135	<u>10,068</u>	<u>2</u>	<u>199</u>	2-MARGINAL LEAKAGE
SUBTOTAL			30,888	3	97	
SMG PROCESS						
ICM7218CPI	XDDCAA096A	135	6886	0	0.0	
	XDDCAA102A	135	6824	2	293	1-MARGINAL LEAKAGE, 1-UNKNOWN
ICM7218AIP	XDDAAA097A	135	6694	0	0.0	
	XDDAAA098A	135	6927	0	0.0	
ICM7218BIP	XDDBAA099B	135	<u>6959</u>	<u>0</u>	<u>0.0</u>	
SUBTOTAL			34,290	2	58.3	
ICM7218AIP	BDDACZ012Q	135	11,674	1	85	1-UNKNOWN
	BDDACA015B	135	3101	1	322	1-UNKNOWN
ICM7218BIP	BDDBCZ010Q	135	<u>12,355</u>	<u>1</u>	<u>80</u>	1-UNKNOWN
SUBTOTAL			27,130	3	110	
MAX1232CPA	XPPAJQ003BR	135	844	0	0.0	
	XPPAJQ003C	135	6447	2	310	1-DIE SCRATCH, 1-PACKAGE CRACK
	XPPAJQ006A	135	12,390	0	0.0	
	XPPAJQ007B	135	<u>13,330</u>	<u>0</u>	<u>0.0</u>	
SUBTOTAL			33,011	2	60.6	
MAX232CPE	XPWAAA039AA	150	5324	0	0.0	
	XPWAAA040AA	150	5627	1	177.7	1-INTERMITTENT BOND WIRE OPEN (HEEL OF WEDGE BOND)
	XPWAAA044AB	150	5831	0	0.0	
	XPWAAA048AB	125	5575	2	358.7	2-BOND WIRE SHORT FAILURES
	XPWAAA050AA	125	5768	2	346.7	1-MECHANICAL DAMAGE, 1-GATE-OXIDE DEFECT
	XPWAAA074AA	150	4643	3	646.1	1-INTERMITTENT BOND WIRE OPEN (HEEL OF WEDGE BOND), 1-GATE-OXIDE DEFECT, 1-MARG. HIGH R _{IN} THRESHOLD (CAUSE UNKNOWN)
	XPWAAA147A	150	10,372	2	192.8	1-BOND WIRE OPEN WEDGE BONDS @ LEADFRAME, 1-HIGH I _{EE} DUE TO GATE-OXIDE DEFECT
	XPWAAA147B	150	10,789	0	0.0	
	XPWBAA012A	150	10,070	3	297.9	1-LOW R _{1IN} RESISTANCE SCRATCH ON DIE, 1-HIGH I _{EE} GATE-OXIDE DEFECT, 1-HIGH R _{2IN} RESISTANCE ERR. FUSE BLOWN
	XPWBAA012B	150	10,929	3	274.5	1-HIGH R _{1IN} RESISTANCE ERR. FUSE BLOWN, 1-T _{1OUT} STUCK HIGH UNKNOWN DAMAGE IN FA, 1-R _{2IN} INPUT THRESHOLD MARG. FAIL
MAX232CPE	XKMAAA005Q	135	15,727	2	127	2-UNKNOWN
MAX202CPE	XKMCAA007A	135	6277	1	159	1-UNKNOWN
MAX232CPE	XKMAAA008A	135	<u>30,888</u>	<u>1</u>	<u>32</u>	1-UNKNOWN
SUBTOTAL			128,330	20	155.8	
MAX690CPA	XPYAJA208A	150	9443	4	423.6	1-AC FAILURE NO SCRATCH, 2-MARGINAL HIGH RESET THRESHOLD NO SCRATCH,
	XPYAJA208BA	150	4702	3	638.0	1-FUNCTIONAL FAILURE DUE TO DIE SCRATCH 2-DIE SCRATCH ON SILICON SUBSTRATE,
	XPYAJA209A	150	9873	3	303.9	1-DIE SCRATCH ON METAL LINES 1-RESET THRESHOLD DUE TO DIE SCRATCH,
	XPYAJA208B	150	<u>4295</u>	<u>0</u>	<u>0.0</u>	1-MARGINAL I _{BAT} NO SCRATCH, 1-GATE-OXIDE RUPTURE POSSIBLY ESD DAMAGE
SUBTOTAL			28,313	10	353.2	

Product Reliability Report

RR-1J

TABLE 4. INFANT MORTALITY EVALUATION RESULT (continued)

PRODUCT	LOT	BI TEMP (°C)	SS	FAILURES	PPM	ANALYSIS
MAX667CPA	XEVAJA035A	135	9823	1	102	1-PARAMETRIC
	XEVANA046A	135	8201	5	610	1-PARAMETRIC, 3-FUNCTIONAL
	XEVANB048B	135	<u>5015</u>	<u>0</u>	<u>0</u>	1-UNKNOWN
SUBTOTAL			23,039	6	260	
SG3 PROCESS						
MAX485CPA	XKNACA009A	135	8654	1	115	1-LEAKAGE
	XKNACA011A	135	9689	2	206	2-UNKNOWN
	XKNACB016C	135	<u>6239</u>	<u>1</u>	<u>160</u>	1-UNKNOWN
SUBTOTAL			24,582	4	162	
MAX705CPA	XTOACZ010A	135	7026	1	142	1-HIGH I _{CC}
	XTOACA014Q	135	6759	2	295	2-PARAMETRIC
	XTOACB015B	135	<u>4895</u>	<u>0</u>	<u>0</u>	
SUBTOTAL			18,680	3	160	
MAX712CPE	XAABCA009A	135	12,505	3	239	3-PARAMETRIC
MAX713CPE	XAAACA013A	135	11,873	2	168	2-PARAMETRIC
	XAAACA016A	135	<u>10,530</u>	<u>2</u>	<u>189</u>	1-FUNCTIONAL, 1-PARAMETRIC
SUBTOTAL			34,908	7	200	
MAX692ACPA	NTABGO01O	135	<u>12,033</u>	<u>2</u>	<u>166</u>	2-PARAMETRIC
SUBTOTAL			12,033	2	166	
SG5 PROCESS						
MAX232ACPE	XETAZZ063Q	135	10,016	6	599	2-BOND WIRE SHORT TO DIE EDGE, 1-BOND WIRE SMASH, 1-DIE SCRATCH, 1-HIGH I _{CC} , 1-LOW SLEW RATE
MAX232ACPE	XETAZZ058Q	135	10,181	1	98	1-OXIDE DEFECT
MAX202ACPE	XETAZA075A	135	14,977	4	267	2-DIE SCRATCH, 2-UNKNOWN
MAX232ACPE	XETAZA099Q	135	<u>10,425</u>	<u>3</u>	<u>288</u>	3-HIGH I _{CC}
SUBTOTAL			45,599	14	307	
MAX452CPA	XFPAUB004A	135	5592	2	358	2-V _{OS}
MAX454CPD	XFPAVA011Q	135	6565	0	0	
MAX455CPP	XFPAVA009Q	135	<u>16,236</u>	<u>5</u>	<u>308</u>	4-V _{OS} , 1-FUNCTIONAL FAILURE
SUBTOTAL			28,393	7	246.5	
MAX732CPA	XPKABB254A	135	10,848	2	184	1-AC FAILURE, 1-UNKNOWN
	XPKABB261A	135	11,657	1	86	1-AC FAILURE
	XPKABB263A	135	<u>12,333</u>	<u>2</u>	<u>162</u>	1-AC FAILURE
SUBTOTAL			34,838	5	143	
SG1.2 PROCESS						
MAX7219CNG	BDRAAZ014A	135	10,091	3	297	3-UNKNOWN
	BDRAAZ026B	135	16,648	3	180	3-UNKNOWN
	BDRAAZ029A	135	<u>11,347</u>	<u>1</u>	<u>88</u>	1-UNKNOWN
SUBTOTAL			38,086	7	184	
BIP PROCESS						
MAX901BCPE	VWHABB074C	135	4100	1	243	1-LEAKAGE
	VWHABB079D	135	4650	1	215	1-HIGH I _{CC}
	VWHABB083A	135	6415	0	0	
	VWHABB083B	135	<u>4587</u>	<u>2</u>	<u>436</u>	2-PARAMETRIC
SUBTOTAL			19,752	4	202	
COMBINED TOTAL			625,803	119	190	

Product Reliability Report

RR-1J

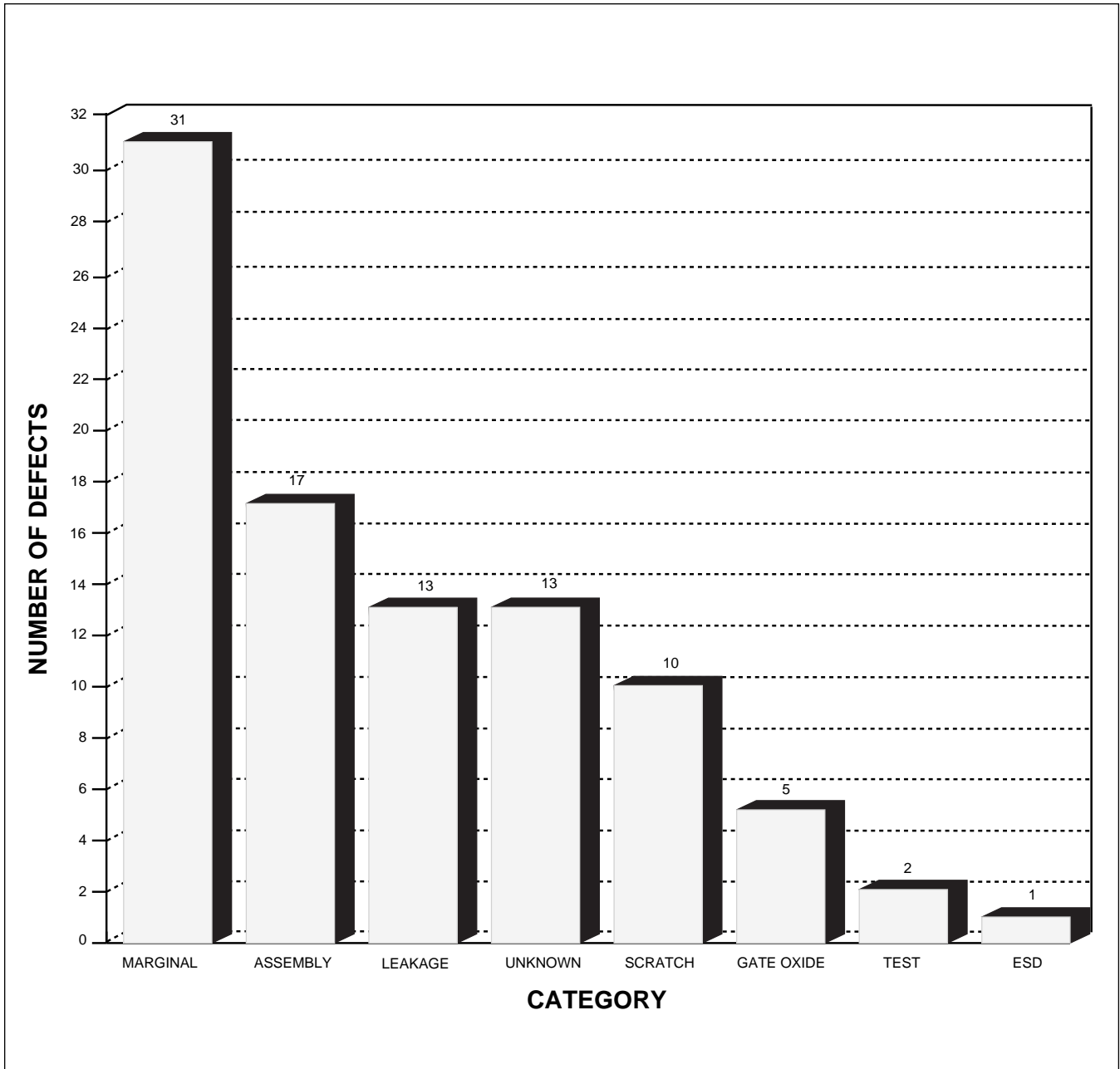

FIGURE 3. INFANT MORTALITY PARETO CHART

Product Reliability Report

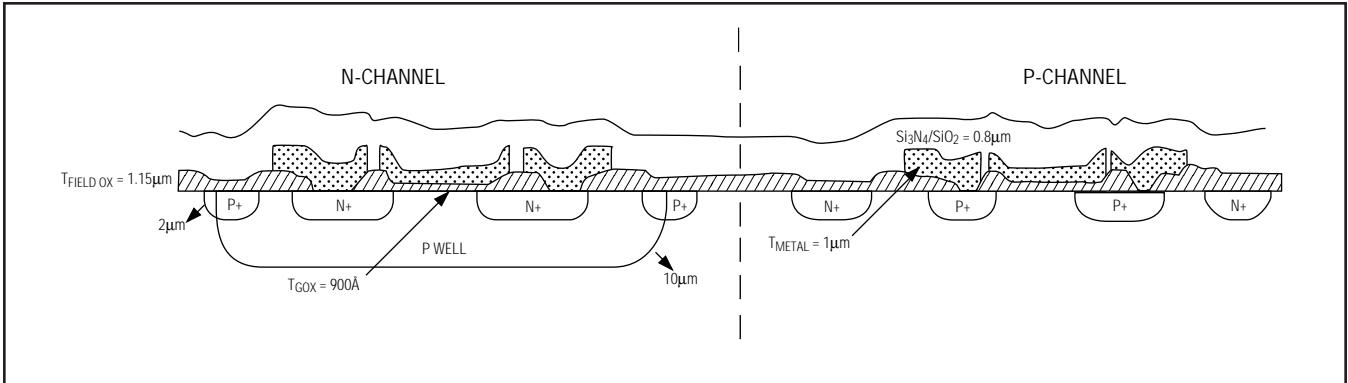

FIGURE 4. SMG PROCESS

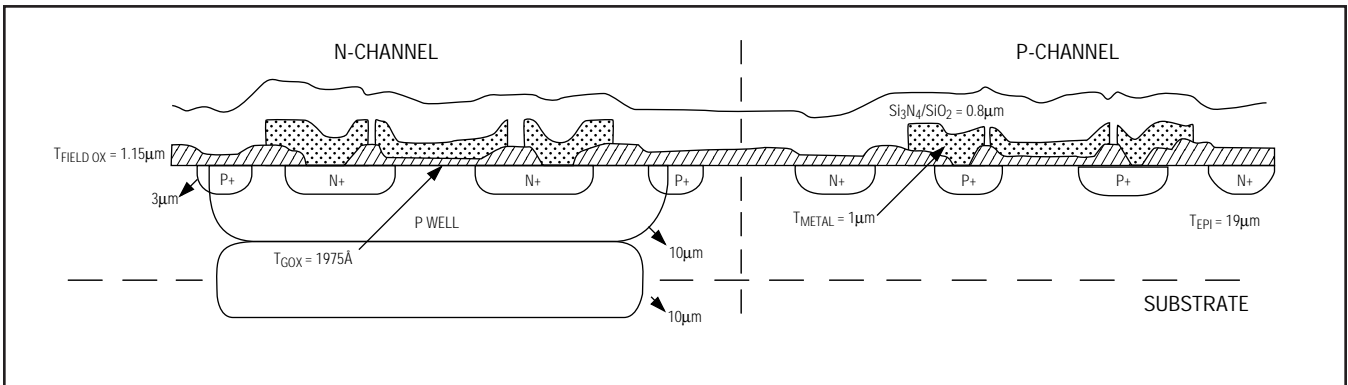

FIGURE 5. MV1 PROCESS

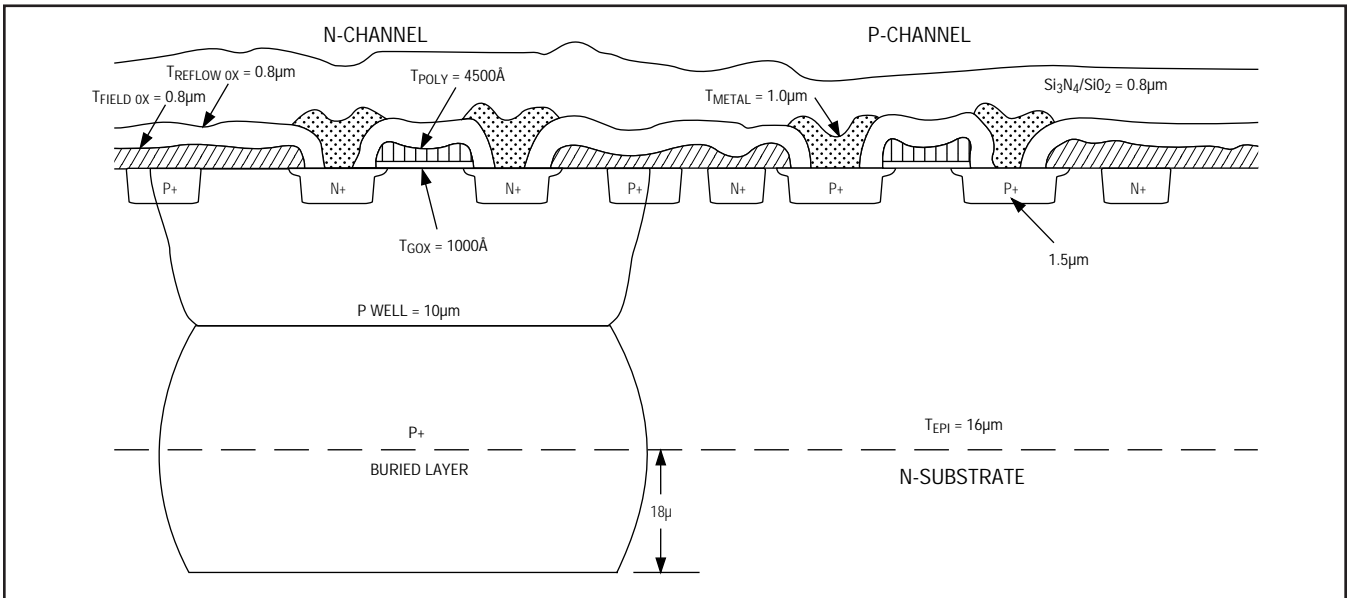

FIGURE 6. MV2 PROCESS

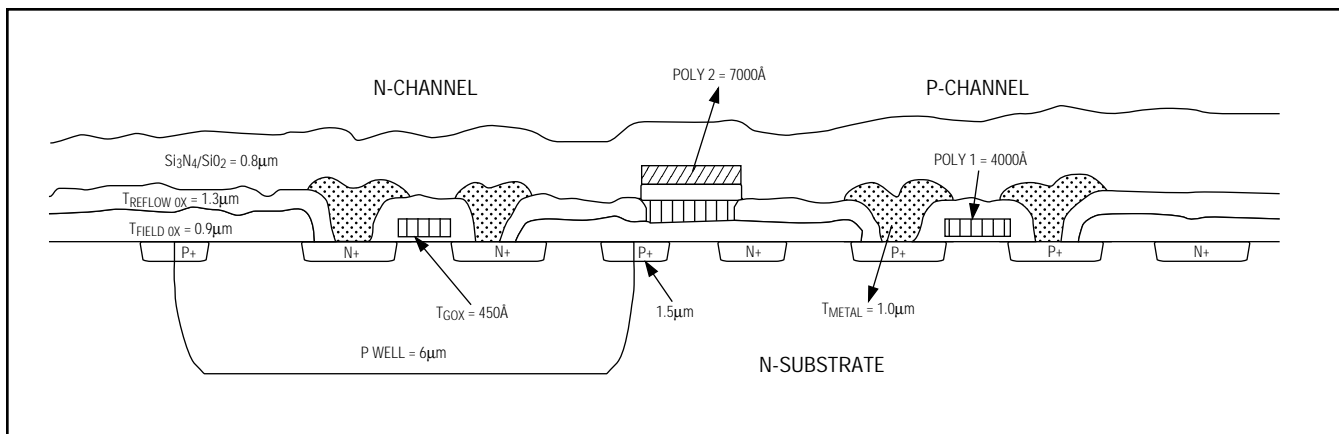

FIGURE 7. SG3 PROCESS

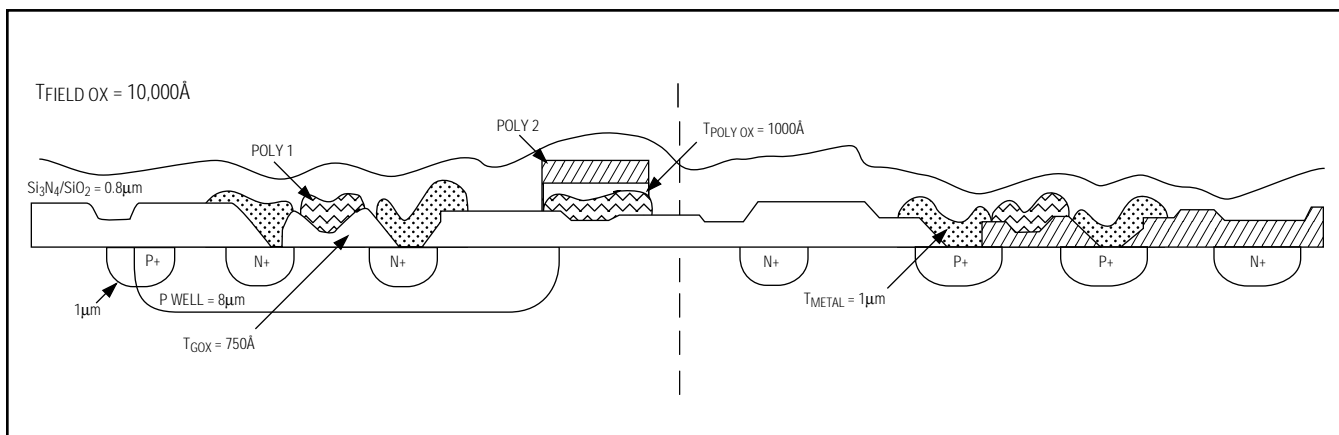

FIGURE 8. SG5 PROCESS

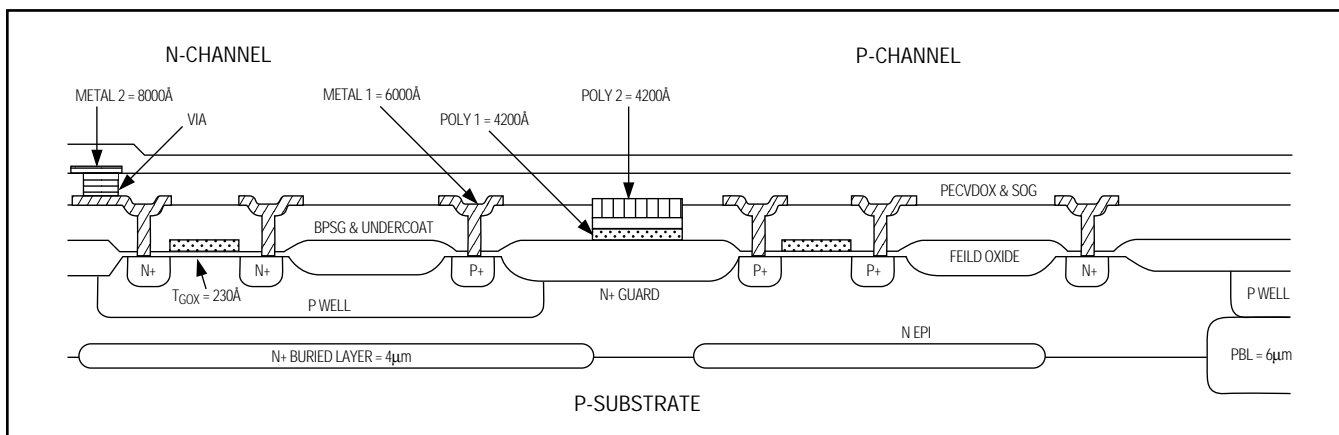

FIGURE 9. SG1.2 PROCESS

Product Reliability Report

RR-1J

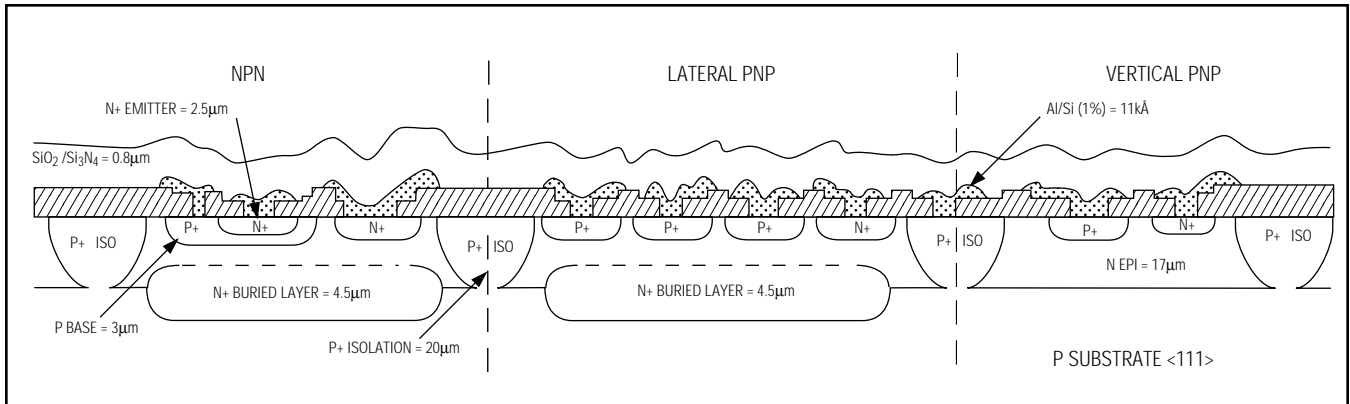

FIGURE 10. BIP PROCESS

TABLE 5. LIFE TEST AT 135°C/1000 HRS. FOR THE METAL-GATE CMOS PROCESS (SMG)

DEVICE TYPE	DATE CODE	PKG.	SAMPLE FAILURES (HRS.)			NOTES	
			SIZE	192	500		1000
MAX691	9413	16 PDIP	80	0	0	0	
MAX241	9440	28 SSOP	77	0	0	0	
MAX202	9441	16 PDIP	77	0	0	0	
MAX700	9441	8 PDIP	80	0	0	0	
MAX202	9442	16 PDIP	77	0	0	0	
MAX696	9442	16 PDIP	77	0	0	0	
MAX241	9442	28 SSOP	77	0	0	0	
ICL7660	9442	8 PDIP	77	0	0	0	
MAX238	9443	24 PDIP	77	0	0	0	
MAX241	9444	28 SSOP	80	0	0	0	
MAX238	9444	24 PDIP	77	0	0	0	
MAX695	9444	16 PDIP	77	0	0	0	
MAX241	9444	28 WSO	80	0	0	0	
ICL7621	9444	8 PDIP	77	0	0	0	
MAX238	9445	24 PDIP	77	0	0	0	
MAX695	9445	16 WSO	77	0	0	0	
MAX232	9446	16 WSO	76	0	0	0	
MAX691	9446	16 PDIP	80	0	0	0	
MAX694	9446	8 PDIP	76	0	0	0	
MAX693	9446	16 WSO	45	0	0	0	
MAX238	9447	24 PDIP	80	0	0	0	
MAX208	9448	24 PDIP	80	0	0	0	
MAX211	9450	28 WSO	70	0	0	0	
MAX232	9450	16 PDIP	77	0	0	0	
ICM7218	9450	28 PDIP	80	0	0	0	
MAX211	9451	28 SSOP	74	0	0	0	
MAX232	9451	16 WSO	77	0	0	0	
ICL7660	9451	8 PDIP	80	0	0	0	
MAX8212	9452	8 PDIP	76	0	0	0	
ICL7665	9501	8 PDIP	77	0	0	0	
MAX237	9502	24 PDIP	77	0	0	0	
ICL7660	9503	8 PDIP	75	0	0	0	
ICL7664	9504	8 PDIP	80	0	0	0	
ICL7109	9505	40 PDIP	79	0	0	0	
ICL7652	9506	14 PDIP	77	0	0	0	
MAX134	9507	40 PDIP	80	0	0	0	
MAX8212	9508	8 NSO	77	0	0	0	
MAX633	9510	8 PDIP	77	0	0	0	
ICL7612	9511	TO99	79	0	0	0	
MAX232	9512	16 PDIP	76	0	0	0	
MAX691	9512	16 PDIP	80	0	0	0	
MAX211	9512	28 WSO	80	0	0	0	
MAX690	9512	8 PDIP	80	0	0	0	
MAX232	9513	16 PDIP	80	0	0	0	
MAX690	9513	8 PDIP	80	0	0	0	
ICL7660	9513	8 PDIP	70	0	0	0	
MAX232	9513	16 PDIP	77	0	0	0	
ICL7660	9514	8 PDIP	80	0	0	0	
ICL7664	9515	8 PDIP	77	0	0	0	
MAX695	9517	16 PDIP	79	0	1	0	PARAMETRIC
MAX232	9518	16 PDIP	80	0	0	0	

TABLE 5 (continued)

DEVICE TYPE	DATE CODE	PKG.	SAMPLE FAILURES (HRS.)			NOTES	
			SIZE	192	500		1000
MAX691	9519	16 CERDIP	77	0	0	0	
MAX690	9519	8 CERDIP	77	0	0	0	
ICL7652	9520	14 PDIP	77	0	0	0	
ICM7218	9522	28 CERDIP	77	0	0	0	
MAX680	9523	8 PDIP	322	0	0	0	
MAX211	9523	28 WSO	76	0	0	0	
MAX211	9524	28 SSOP	77	0	0	0	
MAX236	9525	24 PDIP	75	0	0	0	
MAX239	9525	24 PDIP	78	0	0	0	
MAX8212	9526	8 PDIP	77	0	0	0	
MAX632	9526	8 PDIP	77	0	0	0	
MAX202	9526	16 WSO	79	1	0	0	AC FAILURE
MAX208	9527	24 PDIP	80	0	0	0	
MAX237	9527	24 PDIP	80	0	0	0	
MAX641	9528	8 PDIP	79	0	0	0	
MAX634	9529	8 PDIP	80	0	0	0	
ICM7242	9530	8 PDIP	79	0	0	0	
MAX238	9530	24 PDIP	77	0	0	0	
MAX211	9530	28 SSOP	77	0	0	0	
MAX663	9530	8 PDIP	79	0	0	0	
MAX213	9530	28 WSO	76	0	0	0	
ICL7612	9531	TO99	76	0	0	0	
ICL7660	9531	8 PDIP	71	0	0	0	
MAX632	9531	8 PDIP	77	0	0	0	
MAX232	9532	16 PDIP	77	0	0	0	
MAX8211	9533	TO99	75	0	0	0	
MAX8211	9533	8 PDIP	77	0	0	0	
ICL7660	9533	8 PDIP	72	0	0	0	
MAX695	9535	16 PDIP	78	1	0	0	BOND CRATER
MAX690	9537	8 PDIP	77	0	0	0	
MAX211	9537	28 WSO	77	0	0	0	
MAX850	9537	8 NSO	79	0	0	0	
MAX695	9538	16 PDIP	76	0	0	0	
MAX232	9538	16 PDIP	77	0	0	0	
ICL7621	9538	8 PDIP	77	0	0	0	
MAX8211	9538	8 NSO	75	0	0	0	
MAX202	9538	16 WSO	76	0	0	0	
MAX690	9538	8 PDIP	77	0	0	0	
MAX232	9539	16 PDIP	77	0	0	0	
MAX850	9540	8 NSO	80	0	0	0	
MAX211E	9542	28 SSOP	77	0	0	0	
MAX666	9542	8 PDIP	80	0	0	1	PARAMETRIC
MAX241E	9544	28 SSOP	45	0	0	0	
MAX211E	9545	28 SSOP	76	0	0	0	
ICL7621	9545	8 PDIP	77	0	0	0	
TOTAL			7614	2	1	1	

Note: Products included in this Life Test data are: A/D Converters, Operational Amplifiers, Power-Supply Circuits, Interface, and Display Drivers/Counters.

Product Reliability Report

RR-1J

TABLE 6. LIFE TEST AT 135°C/1000 HRS. FOR THE MEDIUM-VOLTAGE METAL-GATE CMOS PROCESS (MV1)

DEVICE TYPE	DATE CODE	PKG. SIZE	SAMPLE SIZE	FAILURES (HRS.)			NOTES
				192	500	1000	
DG211	9432	16 NSO	36	0	0	0	
DG202	9520	16 CERDIP	75	0	0	0	
MAX333	9520	20 CERDIP	77	0	0	0	
DG211	9524	16 PDIP	77	0	0	0	
DG211	9537	16 NSO	36	0	0	0	
DG304	9537	16 PDIP	77	0	0	0	
TOTAL			378	0	0	0	

Note: Products included in this Life Test data are: Analog Switches and Analog Multiplexers.

TABLE 7. LIFE TEST AT 135°C/1000 HRS. FOR THE MEDIUM-VOLTAGE SILICON-GATE CMOS PROCESS (MV2)

DEVICE TYPE	DATE CODE	PKG. SIZE	SAMPLE SIZE	FAILURES (HRS.)			NOTES
				192	500	1000	
DG421	9441	16 PDIP	77	0	0	0	
DG445	9449	16 PDIP	75	0	0	0	
MAX306	9521	28 CERDIP	77	0	0	0	
DG441	9536	16 PDIP	77	0	0	0	
TOTAL			306	0	0	0	

TABLE 8. LIFE TEST AT 135°C/1000 HRS. FOR THE 3µm SILICON-GATE CMOS PROCESS (SG3)

DEVICE TYPE	DATE CODE	PKG. SIZE	SAMPLE SIZE	FAILURES (HRS.)			NOTES
				192	500	1000	
MAX687	9441	8 PDIP	75	0	0	0	
MAX921	9443	8 PDIP	75	0	0	0	
MAX691A	9444	16 WSO	79	0	0	0	
MAX781	9510	36 SSOP	140	0	0	0	
MAX809	9512	3 SOT23	69	0	0	0	
MAX705	9512	8 PDIP	75	0	0	0	
MAX809	9514	3 SOT23	75	0	0	0	
MAX704	9517	8 PDIP	77	0	0	0	
MAX856	9519	8 PDIP	77	0	0	0	
MAX860	9519	8 PDIP	75	0	0	0	
MAX705	9522	8 PDIP	77	0	0	0	
MAX703	9522	8 PDIP	77	0	0	0	
MAX662	9524	8 PDIP	74	0	0	0	
MAX660	9526	8 PDIP	77	0	0	0	
MAX791	9526	16 PDIP	77	0	0	0	
MAX691A	9526	16 PDIP	77	0	0	0	
MAX690A	9526	8 PDIP	80	0	0	0	
MAX662	9527	8 PDIP	77	1	0	0	GATE OXIDE DEFECT
MAX786	9527	28 SSOP	42	0	0	0	
MAX767	9527	20 SSOP	78	0	0	0	
MX7821	9527	20 PDIP	77	0	0	0	
MAX707	9527	8 PDIP	77	0	0	0	
MAX722	9528	16 NSO	78	0	0	0	
MAX192	9529	20 PDIP	45	0	0	0	
MAX662	9529	8 PDIP	77	0	0	0	
MAX757	9530	8 PDIP	80	0	0	0	
MAX222	9530	18 PDIP	80	0	0	0	
MAX485	9535	8 PDIP	76	0	0	0	
MAX1487	9536	8 PDIP	77	0	0	0	
MAX662	9536	8 PDIP	76	0	0	0	
MAX660	9536	8 PDIP	77	0	0	0	
MAX767	9537	20 SSOP	76	1	0	0	LEAKAGE FAILURE
MAX757	9538	8 PDIP	64	0	0	0	
MAX188	9538	20 PDIP	77	0	0	0	
MAX660	9539	8 PDIP	76	0	0	0	
MAX705	9540	8 PDIP	77	0	0	0	
MAX791	9540	16 PDIP	80	0	0	0	
MAX709	9543	8 PDIP	77	0	0	0	
MAX807	9546	16 PDIP	60	0	0	0	
MAX122	9546	24 PDIP	80	0	0	0	
MAX791	9547	16 NSO	79	0	0	0	
MAX921	9547	8 NSO	68	0	0	0	
TOTAL			3187	2	0	0	

TABLE 9. LIFE TEST AT 135°C/1000 HRS. FOR THE 5µm SILICON-GATE CMOS PROCESS (SG5)

DEVICE TYPE	DATE CODE	PKG. SIZE	SAMPLE SIZE	FAILURES (HRS.)			NOTES
				192	500	1000	
MX7543	9434	16 PDIP	80	0	0	0	
MAX249	9442	44 QFP	75	0	0	0	
MAX249	9445	44 QFP	76	0	0	0	
MAX155	9447	28 PDIP	77	0	0	0	
MAX232A	9512	16 PDIP	77	0	0	0	
MX574	9514	28 PDIP	77	0	0	0	
MX7226	9519	20 CERDIP	77	0	0	0	
MAX528	9522	20 PDIP	79	0	0	0	
MX7574	9526	18 PDIP	77	0	0	0	
MAX232A	9526	16 PDIP	77	0	0	0	
MAX232A	9532	16 CERDIP	77	0	0	0	
MAX160	9534	18 PDIP	77	0	0	0	
TOTAL			926	0	0	0	

Note: Products included in this Life Test data are: A/D Converters, D/A Converters, Interface, and Switched Capacitor Filters.

TABLE 10. LIFE TEST AT 135°C/1000 HRS. FOR THE BIPOLAR PROCESS (BIP)

DEVICE TYPE	DATE CODE	PKG. SIZE	SAMPLE SIZE	FAILURES (HRS.)			NOTES
				192	500	1000	
MAX471	9440	8 PDIP	80	0	0	0	
MAX584	9507	TO99	77	0	0	0	
MAX788	9509	TO220	80	0	0	0	
MAX830	9517	16 WSO	74	0	0	0	
REF01	9518	8 PDIP	77	0	0	0	
MAX724	9520	TO220	45	0	0	0	
MAX787	9528	TO220	80	1	0	0	PARAMETRIC
REF01	9528	8 PDIP	77	0	0	1	PARAMETRIC
MAX724	9528	TO220	45	0	0	0	
MAX830	9533	16 WSO	75	0	0	0	
TOTAL			710	1	0	1	

Note: Products included in this Life Test data are: Voltage References and Operational Amplifiers.

TABLE 11. LIFE TEST AT 85°C/1000 HRS. FOR THE 1.2µm SILICON-GATE CMOS PROCESS (SG1.2)

DEVICE TYPE	DATE CODE	PKG. SIZE	SAMPLE SIZE	FAILURES (HRS.)			NOTES
				192	500	1000	
MAX7219	9429	24 PDIP	80	0	0	0	
MAX7219	9436	24 PDIP	77	0	0	0	
MAX7219	9448	24 PDIP	77	0	0	0	
MAX7219	9521	24 PDIP	74	0	0	0	
MAX7219	9528	24 PDIP	77	0	0	0	
MAX7219	9546	24 PDIP	77	0	0	0	
MAX7219	9552	24 PDIP	77	0	0	0	
TOTAL			539	0	0	0	

Product Reliability Report

RR-1J

TABLE 12. TEMPERATURE AND HUMIDITY (85/85) TEST RESULTS

DEVICE TYPE	DATE CODE	PKG.	SAMPLE SIZE	FAILURES (HRS.)			NOTES
				168	500	1000	
MAX7219	9429	24 PDIP	45	0	0	0	
MAX7219	9436	24 PDIP	45	0	0	0	
MAX241	9440	28 SSOP	45	0	0	0	
MAX202	9441	16 PDIP	45	0	0	0	
MAX687	9441	8 PDIP	77	0	0	0	
DG421	9441	16 PDIP	77	0	0	0	
MAX249	9442	44 QFP	30	0	0	0	
MAX241	9442	28 SSOP	35	0	0	0	
MAX696	9442	16 PDIP	45	0	0	0	
MAX202	9442	16 PDIP	44	0	0	0	
MAX238	9443	24 PDIP	36	0	0	0	
MAX238	9444	24 PDIP	36	0	0	0	
ICL7621	9444	8 PDIP	45	0	0	0	
MAX695	9444	16 PDIP	45	0	0	0	
MAX691A	9444	16 WSO	44	0	0	0	
MAX238	9445	24 PDIP	36	0	0	0	
MAX695	9445	16 WSO	45	0	0	0	
MAX694	9446	8 PDIP	45	0	0	0	
MAX232	9446	16 WSO	26	0	0	0	
MAX693	9446	16 WSO	40	0	0	0	
MAX698	9447	8 PDIP	45	0	0	0	
MAX7219	9448	24 PDIP	45	0	0	0	
MAX213	9448	28 SSOP	29	0	0	0	
DG445	9449	16 PDIP	45	0	0	0	
MAX232	9450	16 PDIP	77	0	0	0	
MAX211	9451	28 SSOP	24	0	0	0	
MAX232	9451	16 WSO	26	0	0	0	
REF01	9451	8 NSO	74	0	0	0	
MAX8212	9452	8 PDIP	45	0	0	0	
ICL7665	9501	8 PDIP	45	0	0	0	
MAX237	9502	24 PDIP	44	0	0	0	
ICL7665	9506	14 PDIP	45	0	0	0	
MAX235	9508	24 PDIP	42	0	0	0	
MAX8212	9508	8 NSO	77	0	0	0	
MAX235	9510	24 PDIP	42	0	0	0	
MAX633	9510	8 PDIP	44	0	0	0	
REF01	9511	8 NSO	77	0	0	0	
MAX705	9512	8 PDIP	77	0	0	0	
MAX232A	9512	16 PDIP	45	0	0	0	
MAX232	9513	16 PDIP	44	0	0	0	
DG302	9513	16 WSO	43	0	0	0	
MX574	9514	28 PDIP	44	0	0	0	
MAX485	9515	8 NSO	74	0	0	0	
MAX704	9517	8 PDIP	45	0	0	0	
REF01	9518	8 PDIP	77	0	0	0	
MAX233	9518	20 PDIP	36	0	0	0	
MAX856	9519	8 PDIP	77	0	0	0	
MAX724	9520	TO220	45	0	0	0	
MAX7219	9521	24 PDIP	45	0	0	0	
MAX703	9522	8 PDIP	45	0	0	0	
MAX705	9522	8 PDIP	43	0	0	0	
MAX662	9523	8 NSO	44	0	0	0	
MAX662	9524	8 PDIP	45	0	0	0	
MAX236	9525	24 PDIP	45	0	0	0	
MAX691A	9526	16 PDIP	45	0	0	0	
MAX791	9526	16 PDIP	45	0	0	0	
MAX660	9526	8 PDIP	46	0	0	0	
MAX632	9526	8 PDIP	77	0	0	0	
MAX8211	9526	8 PDIP	77	0	0	0	
MAX707	9527	8 PDIP	44	0	0	0	
MAX662	9527	8 PDIP	45	0	0	0	
MX7821	9527	20 PDIP	45	0	0	0	
MAX724	9528	TO220	45	0	0	0	
REF01	9528	8 PDIP	77	0	0	0	
MAX7219	9528	24 PDIP	45	0	0	0	
MAX662	9529	8 PDIP	44	0	0	0	
MAX192	9529	20 PDIP	45	0	0	0	
MAX213	9530	28 WSO	43	0	0	0	
MAX238	9530	24 PDIP	36	0	0	0	
MAX211	9530	28 SSOP	29	0	0	0	
ICL7660	9531	8 PDIP	43	0	0	0	
MAX632	9531	8 PDIP	45	0	0	0	
MAX706	9532	8 NSO	76	0	0	0	
ICL7660	9533	8 PDIP	45	0	0	0	
MAX8211	9533	8 PDIP	77	0	0	0	

TABLE 12 (continued)

DEVICE TYPE	DATE CODE	PKG.	SAMPLE SIZE	FAILURES (HRS.)			NOTES
				168	500	1000	
MAX707	9534	8 PDIP	44	0	0	0	
MAX713	9534	16 PDIP	44	0	0	0	
MAX485	9534	8 PDIP	45	0	0	0	
MAX485	9535	8 PDIP	45	0	0	0	
MAX1487	9536	8 PDIP	45	0	0	0	
MAX662	9536	8 PDIP	45	0	1	0	PARAMETRIC
MAX660	9536	8 PDIP	43	0	0	0	
DG441	9536	16 PDIP	77	0	0	0	
MAX690	9537	8 PDIP	45	0	0	0	
MAX211	9537	28 WSO	45	0	0	0	
MAX695	9538	16 PDIP	45	0	0	0	
MAX690	9538	8 PDIP	45	0	0	0	
MAX188	9538	20 PDIP	36	0	0	0	
MAX757	9538	8 PDIP	45	0	0	0	
MAX202	9538	16 WSO	26	0	0	0	
MAX8211	9538	8 NSO	44	0	0	0	
MAX660	9539	8 PDIP	45	0	0	0	
MAX705	9540	8 PDIP	45	0	0	0	
MAX211E	9542	28 SSOP	45	0	0	0	
MAX709	9543	8 PDIP	44	0	0	0	
MAX211E	9545	28 SSOP	45	0	0	0	
ICL7621	9545	8 PDIP	45	0	0	0	
MAX7219	9546	24 PDIP	45	0	0	0	
MAX7219	9553	24 PDIP	45	0	0	0	
TOTAL			4738	0	1	0	

TABLE 13. PRESSURE POT TEST AT 121°C/100% RH 15 PSIG/168 HRS. (ALL PLASTIC PACKAGES)

DEVICE TYPE	DATE CODE	PKG.	SAMPLE SIZE	FAILURES (HRS.)	NOTES
				168	
MAX7219	9429	24 PDIP	77	0	
MAX7219	9436	24 PDIP	41	0	
MAX241	9440	28 SSOP	45	0	
MAX202	9441	16 PDIP	77	0	
DG421	9441	16 PDIP	45	0	
MAX687	9441	8 PDIP	45	0	
MAX249	9442	44 QFP	45	0	
MAX202	9442	16 PDIP	77	0	
ICL7660	9442	8 PDIP	77	0	
MAX241	9442	28 SSOP	45	0	
MAX782	9442	36 SSOP	45	0	
MAX238	9443	24 PDIP	77	0	
ICL7621	9444	8 PDIP	77	0	
MAX238	9444	24 PDIP	77	0	
MAX249	9445	44 QFP	45	0	
MAX695	9445	16 WSO	45	0	
MAX238	9445	24 PDIP	77	0	
MAX694	9446	8 PDIP	76	0	
MAX232	9446	16 WSO	77	0	
MAX693	9446	16 WSO	77	0	
MAX238	9447	24 PDIP	45	0	
MAX155	9447	28 PDIP	45	0	
MAX698	9447	8 PDIP	77	0	
MAX7219	9448	24 PDIP	77	0	
MAX208	9448	24 PDIP	44	0	
ICL7652	9448	8 PDIP	73	0	
MAX213	9448	28 SSOP	77	0	
DG445	9449	16 PDIP	45	0	
MAX631	9449	8 PDIP	45	0	
ICM7218	9450	28 PDIP	45	0	
MAX422	9450	8 PDIP	77	0	
MAX235	9450	24 PDIP	77	0	
MAX232	9450	16 PDIP	44	0	
MAX211	9450	28 WSO	77	0	
REF01	9451	8 NSO	45	0	
MAX232	9451	16 WSO	77	0	
MAX211	9451	28 SSOP	77	0	
MAX8212	9452	8 PDIP	77	0	
MAX209	9452	24 WSO	77	0	
ICL7665	9501	8 PDIP	77	0	
MAX237	9502	24 PDIP	77	0	

Product Reliability Report

RR-1J

TABLE 13 (continued)

DEVICE TYPE	DATE CODE	PKG.	SAMPLE SIZE	FAILURES (HRS.) 168	NOTES
MAX756	9503	8 NSO	45	0	
ICL7652	9506	14 PDIP	77	0	
MX7574	9506	18 WSO	45	0	
MAX233	9507	20 PDIP	77	0	
MAX203	9507	20 PDIP	77	0	
MAX8212	9508	8 NSO	45	0	
MAX235	9508	24 PDIP	45	0	
MAX233	9508	20 PDIP	45	0	
MAX235	9510	24 PDIP	45	0	
MAX633	9510	8 PDIP	45	0	
REF01	9511	8 NSO	45	0	
MAX232A	9512	16 PDIP	45	0	
MAX232	9512	16 PDIP	45	0	
MAX809	9512	3 SOT23	45	0	
MAX705	9512	8 PDIP	45	0	
DG302	9513	16 WSO	45	0	
MAX232	9513	16 PDIP	45	0	
MX574	9514	28 PDIP	45	0	
MAX809	9514	3 SOT23	10	0	
MAX485	9515	8 NSO	77	0	
MAX235	9517	24 PDIP	45	0	
MAX704	9517	8 PDIP	45	0	
MAX233	9518	20 PDIP	45	0	
REF01	9518	8 PDIP	45	0	
MAX856	9519	8 PDIP	45	0	
MAX724	9520	TO220	45	0	
MAX681	9520	14 PDIP	77	0	
ICL7665	9520	14 PDIP	77	0	
DG441	9521	16 PDIP	45	0	
MAX7219	9521	24 PDIP	77	0	
MAX705	9522	8 PDIP	77	0	
MAX703	9522	8 PDIP	77	0	
MAX662	9524	8 PDIP	44	0	
MAX236	9525	24 PDIP	45	0	
MX7574	9526	18 PDIP	45	0	
MAX8211	9526	8 PDIP	45	0	
MAX791	9526	16 PDIP	77	0	
MAX232A	9526	16 PDIP	45	0	
MAX632	9526	8 PDIP	45	0	
MX7821	9527	20 PDIP	45	0	
MAX662	9527	8 PDIP	45	0	
MAX707	9527	8 PDIP	45	0	
MAX767	9527	20 SSOP	77	0	
MAX724	9528	TO220	45	0	
MAX7219	9528	24 PDIP	77	0	
MAX660	9528	8 NSO	45	0	
REF01	9528	8 PDIP	45	0	
MAX662	9529	8 PDIP	45	0	
MAX192	9529	20 PDIP	45	0	
MAX211	9530	28 SSOP	45	0	
MAX238	9530	24 PDIP	45	0	
MAX213	9530	28 WSO	44	0	
ICL7660	9531	8 PDIP	44	0	
MAX706	9532	8 NSO	45	0	
MAX232	9532	16 PDIP	45	0	
MAX8211	9533	8 PDIP	45	0	
ICL7660	9533	8 PDIP	45	0	
MAX160	9534	18 PDIP	45	0	
MAX707	9534	8 PDIP	45	0	
MAX485	9534	8 PDIP	45	0	
MAX485	9535	8 PDIP	45	0	
MAX695	9535	16 PDIP	45	0	
MAX662	9536	8 PDIP	45	0	
MAX514	9536	24 PDIP	45	0	
MAX660	9536	8 PDIP	45	0	
DG441	9536	16 PDIP	45	0	
MAX1487	9536	8 PDIP	45	0	
DG304	9537	16 PDIP	45	0	
MAX211	9537	28 WSO	43	0	
MAX134	9537	44 QFP	77	0	
MAX690	9537	8 PDIP	45	0	
MAX708	9538	8 µMAX	45	0	
MAX695	9538	16 PDIP	45	0	
MAX680	9538	8 NSO	77	0	
MAX188	9538	20 PDIP	45	0	

TABLE 13 (continued)

DEVICE TYPE	DATE CODE	PKG.	SAMPLE SIZE	FAILURES (HRS.) 168	NOTES
MAX757	9538	8 PDIP	45	0	
MAX134	9538	44 QFP	77	0	
MAX246	9538	40 PDIP	77	0	
MAX232	9538	16 PDIP	77	0	
MAX202	9538	16 WSO	45	0	
MAX690	9538	8 PDIP	76	0	
MAX8211	9538	8 NSO	44	0	
MAX660	9539	8 PDIP	45	0	
MAX232	9539	16 PDIP	45	0	
MAX211E	9542	28 SSOP	45	0	
MAX709	9543	8 PDIP	45	0	
MAX241E	9544	28 SSOP	45	0	
MAX211E	9545	28 SSOP	45	0	
MAX7219	9546	24 PDIP	45	0	
MAX211E	9546	24 SSOP	45	0	
MAX7219	9553	24 PDIP	45	0	
TOTAL			7231	0	

TABLE 14. HAST TEST RESULTS
120°C/85% RH/BIASED/100 HRS.

DEVICE TYPE	DATE CODE	PKG.	SAMPLE SIZE	FAILURES (HRS.) 100	NOTES
MAX249	9442	44 QFP	25	0	
MAX249	9445	44 QFP	25	0	
MAX809	9512	3 SOT23	25	0	
MAX809	9514	3 SOT23	24	0	
MAX235	9517	24 PDIP	25	0	
MAX681	9520	14 PDIP	25	0	
MAX134	9537	44 QFP	22	0	
MAX134	9538	44 QFP	22	0	
MAX690	9538	8 PDIP	25	0	
MAX8211	9538	8 NSO	25	0	
TOTAL			243	0	

Product Reliability Report

RR-1J

**TABLE 15. TEMPERATURE CYCLING
-65°C TO +150°C 1000 CYCLES
(ALL PACKAGE TYPES)**

DEVICE TYPE	DATE CODE	PKG.	SAMPLE SIZE	FAILURES (HRS.)			NOTES
				200	500	1000	
				x	x	x	
MAX7219	9429	24 PDIP	76	0	0	0	
MX7543	9434	16 PDIP	45	0	0	0	
MAX7219	9436	24 PDIP	45	0	0	0	
MAX241	9440	28 SSOP	77	0	0	0	
MAX202	9441	16 PDIP	45	0	0	0	
DG421	9441	16 PDIP	77	0	0	0	
MAX687	9441	8 PDIP	77	0	0	0	
MAX249	9442	44 QFP	45	0	0	0	
MAX202	9442	16 PDIP	77	0	0	0	
ICL7660	9442	8 PDIP	45	0	0	0	
MAX696	9442	16 PDIP	45	0	0	0	
MAX782	9442	36 SSOP	77	0	0	0	
MAX241	9442	28 SSOP	77	0	0	0	
MAX238	9443	24 PDIP	45	0	0	0	
MAX238	9444	24 PDIP	45	0	0	0	
MAX695	9444	16 PDIP	45	0	0	1	PACKAGE STRESS FAILURE
ICL7621	9444	8 PDIP	45	0	0	0	
MAX238	9445	24 PDIP	45	0	0	0	
MAX249	9445	44 QFP	45	0	0	0	
MAX195	9445	16 SIDEBRAZE	44	0	0	0	
MAX695	9445	16 WSO	77	0	0	0	
MAX693	9446	16 WSO	45	0	0	0	
MAX232	9446	16 WSO	45	0	0	0	
MAX694	9446	8 PDIP	45	0	0	0	
MAX153	9447	28 PDIP	45	0	0	0	
MAX698	9447	8 PDIP	45	0	0	0	
MAX7219	9448	24 PDIP	75	0	0	0	
MAX213	9448	28 SSOP	45	0	0	0	
ICL7652	9448	8 PDIP	45	0	0	0	
DG445	9449	16 PDIP	65	0	0	0	
MAX422	9450	8 PDIP	45	0	0	0	
MAX211	9450	28 WSO	45	0	0	0	
MAX232	9450	16 PDIP	77	0	0	0	
MAX232	9451	16 WSO	45	0	0	0	
MAX211	9451	28 SSOP	45	0	0	0	
REF01	9451	8 NSO	77	0	0	0	
MAX8212	9452	8 PDIP	45	0	0	0	
ICL7665	9501	8 PDIP	45	0	0	0	
MAX237	9502	24 PDIP	45	0	0	0	
MX7574	9506	18 WSO	77	0	0	0	
ICL7652	9506	14 PDIP	45	0	0	0	
MAX584	9507	TO99	77	0	0	0	
MAX8212	9508	8 NSO	76	0	0	0	
MAX633	9510	8 PDIP	74	0	0	0	
REF01	9511	8 NSO	76	0	0	0	
MAX705	9512	8 PDIP	77	0	0	0	
MAX232	9512	16 PDIP	76	0	0	0	
MAX809	9512	3 SOT23	20	0	0	0	
MAX232A	9512	16 PDIP	76	0	0	0	
MAX232	9513	16 PDIP	77	0	0	0	
DG302	9513	16 WSO	76	0	0	0	
MX574	9514	28 PDIP	45	0	0	0	
MAX809	9514	3 SOT23	13	0	0	0	
MAX485	9515	8 NSO	77	0	0	0	
MAX704	9517	8 PDIP	45	0	0	0	
REF01	9518	8 PDIP	77	0	0	0	
MAX691	9519	16 CERDIP	77	0	0	0	
MAX856	9519	8 PDIP	77	0	0	0	
MAX690	9519	8 CERDIP	75	0	0	0	
MAX860	9519	8 CERDIP	77	0	0	0	
MX7226	9519	20 CERDIP	77	0	0	0	
MAX333	9520	20 CERDIP	77	0	0	0	
ICL7652	9520	14 PDIP	77	0	0	0	
DG202	9520	16 CERDIP	76	0	0	0	
MAX724	9520	TO220	45	0	0	0	
MAX7219	9521	24 PDIP	45	0	0	0	
MAX306	9521	28 CERDIP	44	0	0	0	
DG441	9521	16 PDIP	76	0	0	0	
MAX703	9522	8 PDIP	44	0	1	0	PARAMETRIC
ICM7218	9522	28 CERDIP	76	0	0	0	
MAX705	9522	8 PDIP	45	0	0	0	

TABLE 15 (continued)

DEVICE TYPE	DATE CODE	PKG.	SAMPLE SIZE	FAILURES (HRS.)			NOTES
				200	500	1000	
				x	x	x	
MAX662	9523	8 NSO	33	0	0	0	
MAX662	9524	8 PDIP	45	0	0	0	
DG211	9524	16 PDIP	77	0	0	0	
MAX236	9525	24 PDIP	45	0	0	0	
MAX691A	9526	16 PDIP	44	0	0	0	
MAX791	9526	16 PDIP	43	0	0	0	
MAX660	9526	8 PDIP	45	0	0	0	
MAX8212	9526	8 PDIP	77	0	0	0	
MAX632	9526	8 PDIP	75	0	0	0	
MAX232A	9526	16 PDIP	77	0	0	0	
MX7574	9526	18 PDIP	77	0	0	0	
MAX662	9527	8 PDIP	44	0	0	0	
MAX707	9527	8 PDIP	45	0	0	0	
MX7821	9527	20 PDIP	45	0	0	0	
MAX767	9527	20 SSOP	44	0	0	0	
MAX7219	9528	24 PDIP	44	0	0	0	
MAX660	9528	8 NSO	45	0	0	0	
REF01	9528	8 PDIP	77	0	0	0	
MAX724	9528	TO220	45	0	0	0	
MAX662	9529	8 PDIP	45	0	0	0	
DG301	9529	TO100	45	0	0	0	
MAX192	9529	20 PDIP	45	0	0	0	
MAX238	9530	24 PDIP	45	0	0	0	
MAX213	9530	28 WSO	45	0	0	0	
MAX211	9530	28 SSOP	45	0	0	0	
ICL7612	9531	TO99	45	0	0	0	
ICL7660	9531	8 PDIP	44	0	0	0	
MAX632	9531	8 PDIP	77	0	0	0	
MAX232	9532	16 PDIP	45	0	0	0	
MAX232A	9532	16 CERDIP	77	0	0	0	
MAX706	9532	8 NSO	77	0	0	0	
MAX8211	9533	8 PDIP	77	0	0	0	
MAX8211	9533	TO99	44	0	0	0	
ICL7660	9533	8 PDIP	45	0	0	0	
MAX676	9533	20 WSO	53	0	0	0	
MAX676	9533	20 PDIP	52	0	0	0	
MAX707	9534	8 PDIP	45	0	0	0	
MAX160	9534	18 PDIP	77	0	0	0	
MAX485	9534	8 PDIP	45	0	0	0	
MAX713	9534	16 PDIP	44	0	0	0	
MAX695	9535	16 PDIP	45	0	0	0	
MAX485	9535	8 PDIP	44	0	0	0	
MAX662	9536	8 PDIP	45	0	0	0	
MAX660	9536	8 PDIP	45	0	0	0	
DG441	9536	16 PDIP	77	0	0	0	
MAX1487	9536	8 PDIP	45	0	0	0	
MAX690	9537	8 PDIP	45	0	0	0	
MAX211	9537	28 WSO	45	0	0	0	
DG304	9537	16 PDIP	77	0	0	0	
MAX188	9538	20 PDIP	44	0	0	0	
MAX708	9538	8 μMAX	76	0	0	0	
MAX680	9538	8 NSO	44	0	0	0	
MAX757	9538	8 PDIP	44	0	0	0	
ICL7621	9538	8 PDIP	45	0	0	0	
MAX695	9538	16 PDIP	44	0	0	0	
MAX202	9538	16 WSO	45	0	0	0	
MAX8211	9538	8 NSO	44	0	0	0	
MAX690	9538	8 PDIP	44	0	0	0	
MAX232	9538	16 PDIP	45	0	0	0	
MAX660	9539	8 PDIP	45	0	0	0	
MAX232	9539	16 PDIP	77	0	0	0	
MAX705	9540	8 PDIP	45	0	0	0	
MAX211E	9542	28 SSOP	44	0	0	0	
MAX709	9543	8 PDIP	45	0	0	0	
MAX241E	9544	28 SSOP	45	0	0	0	
ICL7621	9545	8 PDIP	45	0	0	0	
MAX211E	9545	28 SSOP	45	0	0	0	
MAX211E	9546	28 SSOP	45	0	0	0	
MAX7219	9546	24 PDIP	45	0	0	0	
MAX7219	9553	24 PDIP	45	0	0	0	
TOTAL			7808	0	1	1	

Product Reliability Report

RR-1J

**TABLE 16. HIGH-TEMPERATURE LIFE TEST,
150°C/1000 HRS. (ALL PACKAGE TYPES)**

DEVICE TYPE	DATE CODE	PKG.	SAMPLE SIZE	FAILURES (HRS.)			NOTES
				192	500	1000	
MAX7219	9429	24 PDIP	77	0	0	0	
MX7543	9434	16 PDIP	45	0	0	0	
MAX7219	9436	24 PDIP	77	0	0	0	
MAX241	9440	28 SSOP	45	0	0	0	
DG421	9441	16 PDIP	45	0	0	0	
MAX687	9441	8 PDIP	43	0	0	0	
MAX202	9441	16 PDIP	77	0	0	0	
MAX241	9442	28 SSOP	45	0	0	0	
MAX202	9442	16 PDIP	77	0	0	0	
MAX249	9442	44 QFP	25	0	0	0	
MAX696	9442	16 PDIP	76	0	0	0	
ICL7660	9442	8 PDIP	77	0	0	0	
MAX238	9443	24 PDIP	77	0	0	0	
MAX238	9444	24 PDIP	77	0	0	0	
ICL7621	9444	8 PDIP	77	0	0	0	
MAX695	9444	16 PDIP	77	0	0	0	
MAX249	9445	44 QFP	25	0	0	0	
MAX695	9445	16 WSO	45	0	0	0	
MAX238	9445	24 PDIP	77	0	0	0	
MAX195	9446	16 SIDEBRAZE	45	0	0	0	
MAX693	9446	16 WSO	77	0	0	0	
MAX232	9446	16 WSO	76	0	0	0	
MAX694	9446	8 PDIP	77	0	0	0	
MAX155	9447	28 PDIP	45	0	0	0	
MAX698	9447	8 PDIP	77	0	0	0	
MAX7219	9448	24 PDIP	77	0	0	0	
ICL7652	9448	8 PDIP	77	0	0	0	
MAX213	9448	28 SSOP	77	0	0	0	
DG445	9449	16 PDIP	45	0	0	0	
MAX422	9450	8 PDIP	77	0	0	0	
MAX232	9450	16 PDIP	45	0	0	0	
MAX211	9450	28 WSO	76	0	0	0	
REF01	9451	8 NSO	45	0	0	0	
MAX211	9451	28 SSOP	77	0	0	0	
MAX8212	9452	8 PDIP	54	0	0	0	
ICL7665	9501	8 PDIP	50	0	0	0	
MAX237	9502	24 PDIP	77	0	0	0	
MX7574	9506	18 WSO	45	0	0	0	
ICL7652	9506	14 PDIP	76	0	0	0	
MX584	9507	TO99	45	0	0	0	
MAX8212	9508	8 NSO	43	0	0	0	
MAX235	9508	24 PDIP	45	0	0	0	
MAX233	9508	20 PDIP	45	0	0	0	
MAX235	9510	24 PDIP	45	0	0	0	
MAX633	9510	8 PDIP	45	0	0	0	
REF01	9511	8 NSO	44	0	0	0	
MAX232A	9512	16 PDIP	45	0	0	0	
MAX232	9512	16 PDIP	45	0	0	0	
MAX705	9512	8 PDIP	45	0	0	0	
MAX809	9512	3 SOT23	32	0	0	0	
DG302	9513	16 WSO	45	0	0	0	
MAX232	9513	16 PDIP	45	0	0	0	
MX574	9514	28 PDIP	45	0	0	0	
MAX809	9514	3 SOT23	15	0	0	0	
MAX485	9515	8 NSO	77	0	0	0	
MAX704	9517	8 PDIP	45	0	0	0	
MAX235	9517	24 PDIP	45	0	0	0	
REF01	9518	8 PDIP	45	0	0	0	
MAX691	9519	16 CERPDP	45	0	0	0	
MAX856	9519	8 PDIP	44	0	0	0	
MAX690	9519	8 CERPDP	45	0	0	0	
MX7226	9519	20 CERPDP	45	0	0	0	
MAX680	9519	8 CERPDP	45	0	0	0	
MAX333	9520	20 CERPDP	45	0	0	0	
ICL7652	9520	14 PDIP	76	0	0	0	
MAX724	9520	TO220	45	0	0	0	
MAX681	9520	14 PDIP	45	0	0	0	
DG202	9520	16 CERPDP	43	0	0	0	
MAX306	9521	28 CERPDP	24	0	0	0	

TABLE 16 (continued)

DEVICE TYPE	DATE CODE	PKG.	SAMPLE SIZE	FAILURES (HRS.)			NOTES
				192	500	1000	
DG441	9521	16 PDIP	45	0	0	0	
MAX7219	9521	24 PDIP	77	0	0	0	
ICM7218	9522	28 CERPDP	45	0	0	0	
MAX703	9522	8 PDIP	77	0	0	0	
MAX705	9522	8 PDIP	77	0	0	0	
DG211	9524	16 PDIP	45	0	0	0	
MAX662	9524	8 PDIP	45	0	0	0	
MAX236	9525	24 PDIP	45	0	0	0	
MAX660	9526	8 PDIP	77	0	0	0	
MAX632	9526	8 PDIP	45	0	0	0	
MAX791	9526	16 PDIP	76	0	0	0	
MX7574	9526	18 PDIP	45	0	0	0	
MAX691A	9526	16 PDIP	77	0	0	0	
MAX8211	9526	8 PDIP	45	0	0	0	
MAX232A	9526	16 PDIP	45	0	0	0	
MAX707	9527	8 PDIP	45	0	0	0	
MAX662	9527	8 PDIP	45	0	0	0	
MX7821	9527	20 PDIP	45	0	0	0	
MAX7219	9528	24 PDIP	77	0	0	0	
REF01	9528	8 PDIP	45	0	0	0	
MAX724	9528	TO220	45	0	0	0	
MAX660	9528	8 NSO	45	0	0	0	
MAX192	9529	20 PDIP	43	0	0	0	
MAX662	9529	8 PDIP	45	0	0	0	
DG301	9529	TO100	45	0	0	0	
MAX213	9530	28 WSO	45	0	0	0	
MAX211	9530	28 SSOP	45	0	0	0	
MAX238	9530	24 PDIP	45	0	0	0	
ICL7612	9531	TO99	45	0	0	0	
MAX632	9531	8 PDIP	45	0	0	0	
ICL7660	9531	8 PDIP	45	0	0	0	
MAX706	9532	8 NSO	45	0	0	0	
MAX232A	9532	16 CERPDP	45	0	0	0	
MAX232	9532	16 PDIP	45	0	0	0	
MAX8211	9533	TO99	45	0	0	0	
ICL7660	9533	8 PDIP	45	0	0	0	
MAX8211	9533	8 PDIP	45	0	0	0	
MAX707	9534	8 PDIP	45	0	0	0	
MAX485	9534	8 PDIP	45	0	0	0	
MAX160	9534	18 PDIP	45	0	0	0	
MAX485	9535	8 PDIP	45	0	0	0	
MAX695	9535	16 PDIP	45	0	0	0	
MAX660	9536	8 PDIP	45	0	0	0	
DG441	9536	16 PDIP	45	0	0	0	
MAX662	9536	8 PDIP	45	0	0	0	
MAX1487	9536	8 PDIP	45	0	0	0	
MAX690	9537	8 PDIP	45	0	0	0	
DG304	9537	16 PDIP	45	0	0	0	
MAX211	9537	28 WSO	44	0	0	0	
ICL7621	9538	8 PDIP	45	0	0	0	
MAX690	9538	8 PDIP	45	0	0	0	
MAX202	9538	16 WSO	45	0	0	0	
MAX695	9538	16 PDIP	45	0	0	0	
MAX232	9538	16 PDIP	45	0	0	0	
MAX8211	9538	8 NSO	44	0	0	0	
MAX680	9538	8 NSO	45	0	0	0	
MAX660	9539	8 PDIP	45	0	0	0	
MAX232	9539	16 PDIP	45	0	0	0	
MAX705	9540	8 PDIP	45	0	0	0	
MAX211E	9542	28 SSOP	44	0	0	0	
MAX709	9543	8 PDIP	43	0	0	0	
MAX241E	9544	28 SSOP	45	0	0	0	
MAX211E	9545	28 SSOP	45	0	0	0	
ICL7621	9545	8 PDIP	45	0	0	0	
MAX211E	9546	28 SSOP	45	0	0	0	
MAX7219	9546	24 PDIP	45	0	0	0	
MAX7219	9553	24 PDIP	45	0	0	0	
TOTAL			7033	0	0	0	

Product Reliability Report

RR-1J

**TABLE 17. HYBRID PRODUCTS
LIFE TEST 135°C/1000 HRS**

DEVICE TYPE	DATE CODE	PKG.	SAMPLE SIZE	FAILURES (HRS.)			NOTES
				192	500	1000	
MAX252	9501	40 PDIP	72	0	0	0	
MAX252	9502	40 PDIP	74	0	0	0	
MAX235	9508	24 PDIP	74	0	0	0	
MAX233	9508	20 PDIP	76	0	0	0	
MAX235	9510	24 PDIP	76	0	0	0	
MAX235	9517	24 PDIP	77	0	0	0	
MAX233	9518	20 PDIP	45	0	0	0	
MAX681	9520	14 PDIP	77	0	0	0	
LH0033	9528	TO8	75	0	0	0	
MAX246	9538	40 PDIP	<u>80</u>	<u>0</u>	<u>0</u>	<u>0</u>	
TOTAL			726	0	0	0	

**TABLE 17. HYBRID PRODUCTS
TEMPERATURE CYCLING -65°C TO +150°C/1000 CYCLES**

DEVICE TYPE	DATE CODE	PKG.	SAMPLE SIZE	FAILURES (HRS.)			NOTES
				200 X	500 X	1000 X	
MAX252	9501	40 PDIP	73	0	0	0	
MAX252	9502	40 PDIP	75	0	0	0	
MAX235	9508	24 PDIP	77	0	0	0	
MAX233	9508	20 PDIP	77	0	0	0	
MAX235	9510	24 PDIP	45	0	0	0	
MAX1480	9510	28 PDIP	77	0	0	0	
MAX1480	9517	28 PDIP	77	0	0	0	
MAX235	9517	24 PDIP	45	0	0	0	
MAX233	9518	20 PDIP	45	0	0	0	
MAX681	9520	14 PDIP	45	0	0	0	
MAX246	9538	40 PDIP	77	0	0	0	
MAX1490	9541	28 PDIP	<u>75</u>	<u>0</u>	<u>0</u>	<u>0</u>	
TOTAL			788	0	0	0	

Appendix 1: ___Determining Acceleration Factor

Definition of Terms

An acceleration factor is a constant used in reliability prediction formulas that expresses the enhanced effect of temperature on a device's failure rate. It is usually used to show the difference (or acceleration effect) between the failure rate at two temperatures. In simple terms, a statement such as, "The failure rate of these devices operating at 150°C is five-times greater than the failure rate at 25°C," implies an acceleration factor of 5.

The acceleration factor used in the semiconductor industry is a result of the Arrhenius equation stated below:

$$\text{Acceleration Factor} = K e^{\frac{E_a}{k} \left(\frac{1}{T_1} - \frac{1}{T_2} \right)}$$

Where:

K = an experimentally determined constant

E_a = the activation energy

k = Boltzmann's constant

T₁ = actual use temp. in degrees Kelvin

T₂ = test temp. in degrees Kelvin

How to Use the Arrhenius Equation

The first step in using the Arrhenius equation given above is to determine an activation energy (E_a), which may be done in one of two ways.

The first method involves using failure analysis techniques to determine the actual failure mechanism. The activation energies for many failure mechanisms have already been determined, and tabulated in published literature. Although all processes are not exactly the same, the activation energy of a particular failure mechanism is mainly determined by physical principles. A published activation energy will not be the exact figure associated with a particular process, but it will be a very close approximation.

The dominant failure mechanisms in Maxim's Life Tests have activation energies in the range of 0.8eV to 1.2eV. We have conservatively chosen 0.8eV for

the purposes of computing the acceleration factors used in this report. Actual acceleration factors are probably greater than those quoted.

The second method of determining an activation energy is empirical. Two groups of devices are tested at different temperatures, and the difference between their failure rates is measured. An example is shown below:

Group 1 = 9822 failures after 100 hrs. of operation at 150°C.

Group 2 = 1 failure after 100 hrs. of operation at 25°C.

The acceleration factor for this particular failure mechanism between these two temperatures is, therefore, 9822.

$$9822 = e^{\frac{E_a}{k} \left(\frac{1}{T_1} - \frac{1}{T_2} \right)}$$

Where:

E_a = the unknown activation energy

k = 8.63 x 10⁻⁵eV/°K

T₁ = 25°C + 273°C or 298°K

T₂ = 150°C + 273°C or 423°K

Substituting:

$$9822 = e^{\frac{E_a}{8.63 \times 10^{-5}} \left(\frac{1}{298} - \frac{1}{423} \right)}$$

$$9822 = e^{E_a \times 11.49}$$

Taking the natural log of both sides:

$$\text{Log}_e 9822 = E_a \times 11.49$$

$$\frac{\text{Log}_e 9822}{11.49} = E_a$$

Therefore, E_a = 0.8eV

Assuming that this activation energy represents the dominant failure mechanism of the device under

Product Reliability Report

consideration, it may then be used to determine the acceleration factor between any two temperatures as follows:

Between 150°C and 70°C, for example:

$$\text{Acceleration Factor} = e^{\frac{0.8}{8.63 \times 10^{-5}} \left(\frac{1}{T_1} - \frac{1}{T_2} \right)}$$

$$T_1 = 70^\circ\text{C} + 273^\circ\text{C} = 343^\circ\text{K}$$

$$T_2 = 150^\circ\text{C} + 273^\circ\text{C} = 423^\circ\text{K}$$

Substituting for $T_1 + T_2$ and solving for e yields the result:

$$\text{Acceleration Factor} = 165$$

The acceleration factor between 150°C and 70°C is 165.

Appendix 2:

Determining Failure Rate

Definition of Terms

The Mean Time Between Failures (MTBF) is the average time it takes for a failure to occur. For example, assume a company tests 100 units for 1000 hrs. The total device-hours accrued would be 100 x 1000, or 100,000 device-hours. Now assume two units were found to be failures. Roughly, it could be said that the MTBF would equal:

$$\text{MTBF} = \frac{\text{Total Device Hrs.}}{\text{Total No. of Failures}} = \frac{100,000}{2} = 50,000 \text{ hrs.}$$

The Failure Rate (FR) is equal to the reciprocal of the MTBF, or:

$$\text{FR} = \frac{1}{\text{MTBF}} = \frac{1}{50,000} = 0.00002$$

If this number is multiplied by 1×10^5 , the failure rate in terms of percent per 1000 hrs. is obtained; i.e., 2%.

A common reliability term also used to express the failure rate is Failures-in-Time, or FIT. This is the number of failures per billion device-hours, and is obtained by dividing the Failure Rate by 10^{-9} :

$$\frac{\text{FR}}{10^{-9}} = \text{FIT.}$$

Using the above example:

$$\begin{aligned} \text{FIT} &= 0.00002/10^{-9} \\ &= 20,000 \end{aligned}$$

The FIT rate is, therefore, shorthand for the number of units predicted to fail in a billion (10^9) device-hours at the specified temperature.

Calculating Failure Rates and FITs

The failure rate can be expressed in terms of the following four variables:

- A = The number of failures observed after test
- B = The number of hours the test was run
- C = The number of devices used in the test
- D = The temperature acceleration factor (see Appendix 1)

Using data in Table 2, a failure rate at 25°C can now be calculated:

$$A = 71$$

$$B = 192$$

$$C = 30,185$$

$$D = 9822 \text{ (Assuming } E_a = 0.8\text{eV, and a test temperature of } 150^\circ\text{C)}$$

Substituting:

$$\text{FR} = \frac{71}{192 \times 30,185 \times 9822} = 1.24 \times 10^{-9}$$

Expressing this in terms of the FIT rate:

$$\text{FIT} = 1.24$$

To determine the FIT rate at a new temperature, the acceleration factor (D) must be recalculated from the Arrhenius equation given in Appendix 1.

Including Statistical Effects in the FIT Calculation

Because a small random sample is being chosen from each lot, the statistical effects are significant enough to mention. With most published failure rate figures, there is an associated confidence level number. This number expresses the confidence level that the actual failure rate of the lot will be equal to or lower than the predicted failure rate.

Product Reliability Report

RR-1J

The failure rate calculation, including a confidence level, is determined as follows:

$$FR = \frac{x^2}{2DH}$$

Where:

X^2 = the Chi square value

2DH = 2 times the total device hours

= 2 x (B x C x D)

The Chi square value is based on a particular type of statistical distribution. However, all that is required to arrive at this value is knowing the number of failures. In this example, there were 71 failures. The Chi square value is found using a standard X^2 distribution table. The tabular values are found using the factors (1 - CL), where CL is the desired confidence level, and 2(N + 1) is the degree of freedom.

The value of (1 - CL) for a 60% confidence level is:
(1 - 0.60) = 0.40.

The number of degrees of freedom equals:
2(71 + 2) = 144.

The Chi square value found under the values of 0.40 and 144 degrees of freedom is: 147.

Therefore, the failure rate found using a 60% confidence level is:

$$FR = \frac{147}{1.50 \times 10^{11}} = 1.29 \times 10^{-9}$$

Expressed as Failure-in-Time rate:

$$FIT = 1.29$$

Referring to Table 2, one can see that for Maxim's product, there is a 60% confidence level that no more than 1.29 units will fail per billion (10^9) device-hours of operation at 25°C.