



ON Semiconductor®

<http://onsemi.com>

A Constant Current Adjustable 0.7 A to 1.5 A, Up to 55 Vdc Single Stage Power Factor Corrected LED Power Supply

APPLICATION NOTE

Prepared by: Frank Cathell

ON Semiconductor

Introduction

This application note describes an up to 90 W, off-line, isolated, single conversion stage power supply with active power factor correction (PFC) intended for LED lighting. In addition to LED drivers, the basic design concept could also be applied to constant current applications such as high power battery chargers. The power supply is designed around ON Semiconductor's NCL30001 single stage, continuous conduction mode (CCM) PFC controller and the NCS1002 secondary side, constant voltage, constant current (CVCC) controller. The specific LED applications in the 40 W – 125 W range that can be addressed by the NCL30001 include end products such as street lights, refrigerator case lighting, low bay lighting, down lights and wall packs. The high current capability of this driver targets LEDs such as the Cree XLamp™ XP-G, Seoul Semiconductor P7, Bridgelux 800 and 1200 lumen LED Arrays, and OSRAM

Platinum and Golden Dragon Plus. The use of these type of LEDs reduces the number of LEDs required and eliminates the need for a two stage power architecture where an offline AC-DC conversion stage is followed by multiple strings of DC-DC constant current stages.

While this supply has been designed to tightly regulate a fixed current, the supply can also operate in a constant voltage mode as the current and voltage are tightly regulated based on the tightly regulated 2.5 V reference within of the NCS1002. The maximum output voltage can be adjusted via selection of a single resistor (R34 in Figure 2), however, it is compliant enough to handle approximately a 1.5:1 range depending on the summed LED forward voltage drop (V_f max), and the output current. The default current has been set at 1.5 A and can be adjusted in a range from 0.7 A – 1.5 A (R32 in Figure 2) to support the specific application needs of the end product.

Target Specifications:

Universal Input:	90 – 265 Vac / 47–63 Hz
Can support 277 Vac (305 Vac max)	with minor component value/rating changes
Power Factor:	> 0.9 (50 – 100% of load)
Harmonic Content	EN61000-3-2 Class C Compliance
Efficiency	> 87% at 50–100% of 50 W, $I_{out} = 1.5$ A / $V_f = 45$ Vdc
Pout Maximum:	90 W
V_{out} max Range:	28 – 58 V (default – 52 V, resistor adjustable)
Constant Current Output	
I_{out} Range:	0.7 – 1.5 A (default – 1.5 A, resistor adjustable)
CC V_{out} Compliance	50% to 100% of V_{out} max.
Current Ripple:	20% max p-p (dependent on C_{out} and I_{out})
Current Tolerance	± 3% or better
Cold Startup	< 500 msec typical to 50% of load
Protection:	Short Circuit Protection Open Circuit Protection < 60 V peak (within UL Class 2) Over Current Protection – Auto recovery

The NCL30001 has a robust suite of protection features. In addition optional protection for latched over temperature and over voltage protection can be implemented.

AND8427/D

Primary Side Circuitry

The primary circuitry is composed of the NCL30001 Continuous conduction mode flyback converter and associated control logic, input EMI filter, and V_{CC} “housekeeping” circuitry (see Figure 1). This circuitry is identical to the primary circuitry shown of AND8397 with

the exception of the V_{CC} regulator circuit for the NCL30001. Components Q3, Z3, and R4 form a simple 15 V regulator to prevent V_{CC} overvoltage due to the wide output compliance voltage that is reflected back to the auxiliary V_{CC} winding.

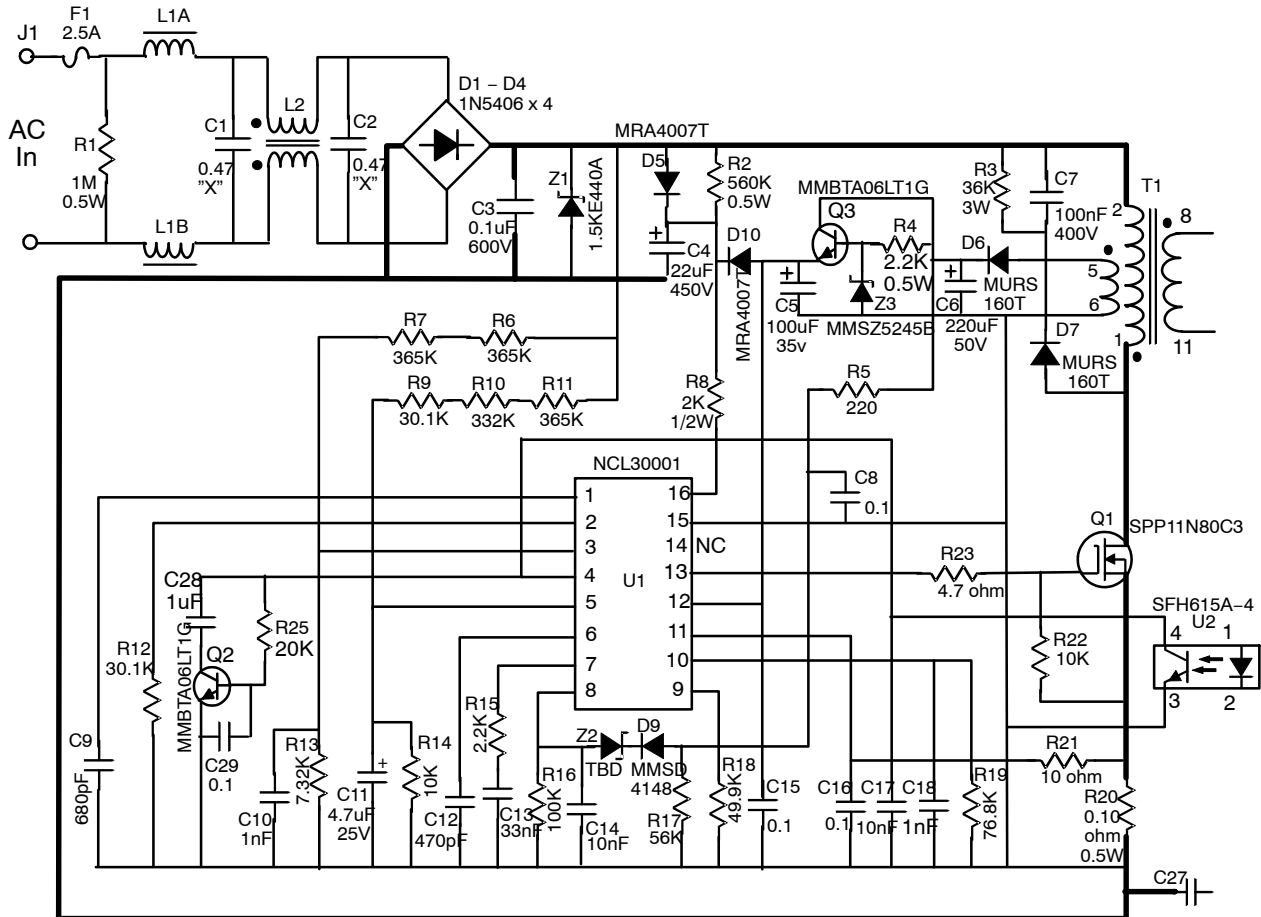

Notes:

1. Crossed schematic lines are not connected.
2. Heavy lines indicate power traces/planes.
3. Z2/D9 is for optional OVP (not used).
4. L1A/B are Coilcraft PCV-0-224-03L or equivalent.
5. L2 is Coilcraft P3220-AL or equivalent.
6. Q1 and D8 will require small heatsinks.

NCL30001 CVCC, 90 Watt Power Supply Primary Control Side Schematic (Rev 2)

Figure 1. Primary Side Circuit Schematic

Secondary Side Control Circuitry

The schematic of Figure 2 shows the secondary side circuitry responsible for the CVCC feedback control and associated circuitry.

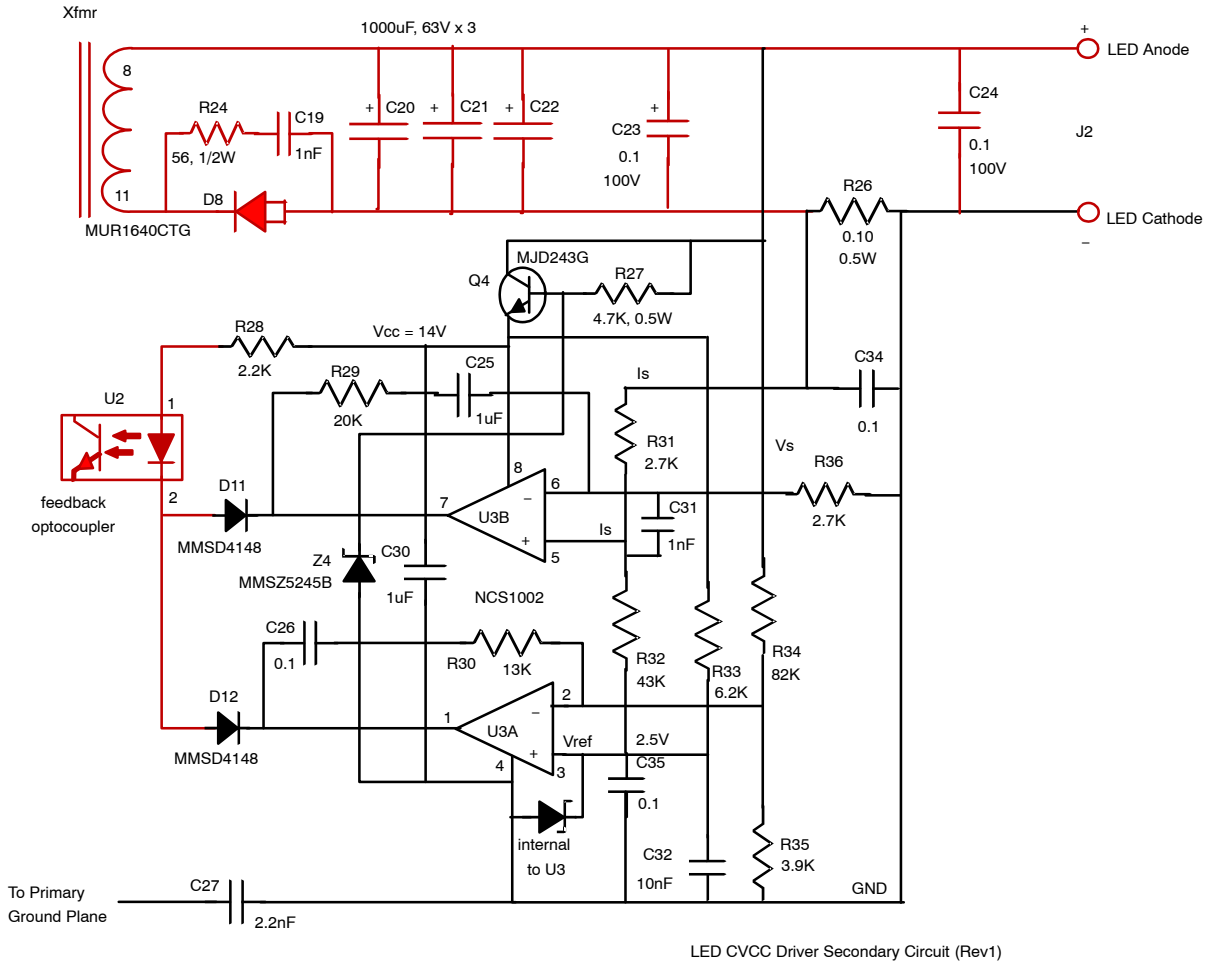

Figure 2. Secondary Side Control Schematic, $I_{out} = 1.5 \text{ A}$ ($R32 = 43\text{k}$)

CVCC Feedback and Control

Voltage and current regulation are achieved by utilizing ON Semiconductor’s NCS1002 secondary side CVCC controller. This chip contains two precision op–amps and an internal 2.5 V reference and is housed in a compact 8 pin SOIC package. The reference is internally connected to the non–inverting input of one of the op–amps. Referring to the schematic of Figure 2, this latter op–amp is used for voltage control (U3A). The power supply output is sensed through resistor divider R34 and R35 and presented to the inverting input of this op–amp section. The resistors are selected so as to provide 2.5 V to pin 3 when the output is at the desired maximum voltage (around 55 V in this case). Frequency compensation is provided by R/C network R30 and C26.

Since both amplifier outputs are “OR ed” via diodes D11 and D12 to drive the optocoupler U2, the amplifier with the lowest output is dominant; hence CVCC control and mode transitions between CV and CC are smooth with no interaction between the op–amps.

Current control is achieved by sensing the output current through R26 and presenting this sense signal to U3B where it is compared to a scaled down value of the 2.5 V internal reference. Because the right hand side of current sense resistor R26 is connected to the secondary logic ground (or common), the sense node on the left hand side of the resistor will go negative with increasing current. The current sense divider network of R31 and R32 is biased up on the low side of R32 by the 2.5 V reference such that when pin 5 of U3B drops to zero, this amplifier becomes dominant and controls the loop (note that the inverting input is grounded via R36.) So the output over–current threshold level is set by adjusting R31 and R32 such that the voltage level presented at pin 5 of U1 at no output load is exactly the voltage drop that will appear across R26 at maximum desired current. In this design example the maximum current is set at 1.5 A, so there must be 150 mV of bias at pin 5 under no output load. Frequency compensation (bandwidth) of the current amplifier is set by R29 and C25.

Secondary V_{CC} Regulator

Since the V_{CC} to run the secondary side circuitry is derived from the main output capacitors, this voltage can vary due to series LED diode Vf compliance, and with the nominal adjusted level of the output voltage. In order to keep the V_{CC} voltage for U3 and the associated circuitry stable, a simple linear regulator composed of Q4, Z4, and R27. This prevents the secondary V_{CC} from exceeding approximately 15 V. This is well below the maximum 32 V capability of the NCS1002.

Test Results and Plots

Efficiency: Efficiencies were measured with a normalized output voltage of 45 V using an electronic LED load simulator.

I _{out} (CC)	120 Vac input	230 Vac input
1.50 A	87%	87.5%
1.25 A	87%	87.5%
1.00 A	86%	86.5%
0.70 A	85.5%	86.0%

The efficiency was impacted most by the nature of the output rectifier D8. In this case an ultra-fast device showed improved efficiency over the soft-recovery, ultra-fast part due to the lower Vf of the diode. For 120 Vac input only applications, further efficiency improvement can be achieved by the use of a 200 V Schottky diode and optimization of snubber network R24 and C19.

Power Factor

The power factor was highest with 120 Vac input nominal and was 0.98 or higher for any of the 4 current level outputs. At 230 Vac input, the power factor was minimum at 0.93 for the 0.7 A output current level. Plots of the line current envelope with a 1 A Constant Current load are shown in Figures 3 and 4.

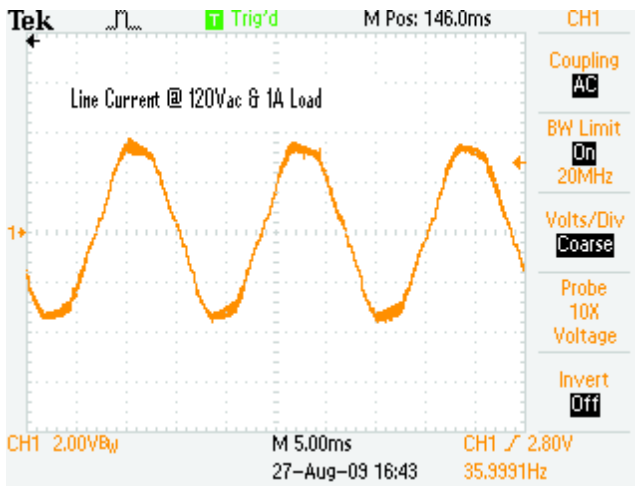

Figure 3. Line Current Envelope; 120 Vac input, 1 A output (PF = 0.98)

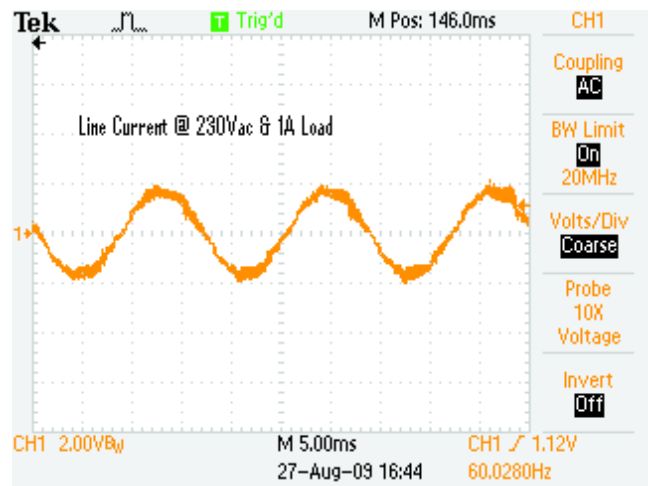

Figure 4. Line Current Envelope; 230 Vac input, 1 A output (PF = 0.97)

Output Current Ripple

The 120 Hz output current ripple was highest at 250 mA peak-to-peak (17%) with max rated load (1.5 A). The ripple profiles are shown in Figures 5 and 6 below for 1.5 A output

and 700 mA output, respectively. The ripple amplitude is directly proportional to dc output current and the output capacitance.

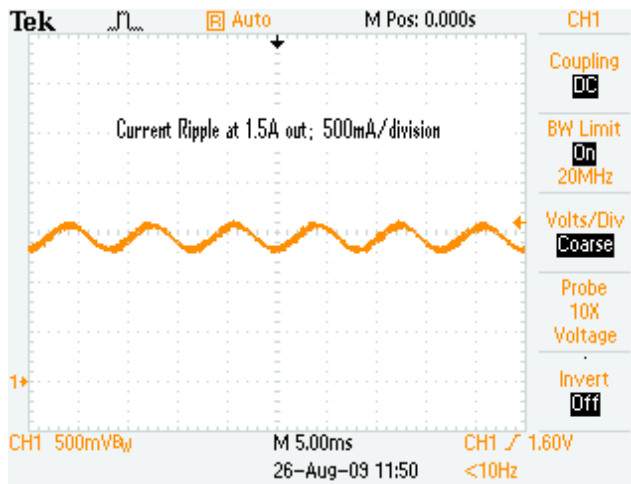

Figure 5. Output Current Ripple at 1.5 A CC Load

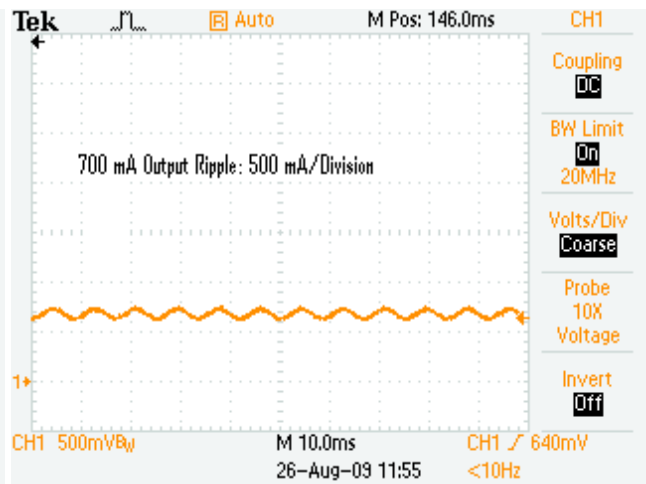

Figure 6. Output Current Ripple at 700 mA CC Load

Output Turn-on Profiles

Power factor corrector circuits necessarily require low bandwidth feedback loops in order to facilitate high power factor. As such, turn-on overshoot can be problematic if the

control loop is not damped sufficiently. Figures 7 and 8 show the output current turn-on profiles for 1.5 A and 700 mA CC loads, respectively. Scale is 500 mA per division vertical.

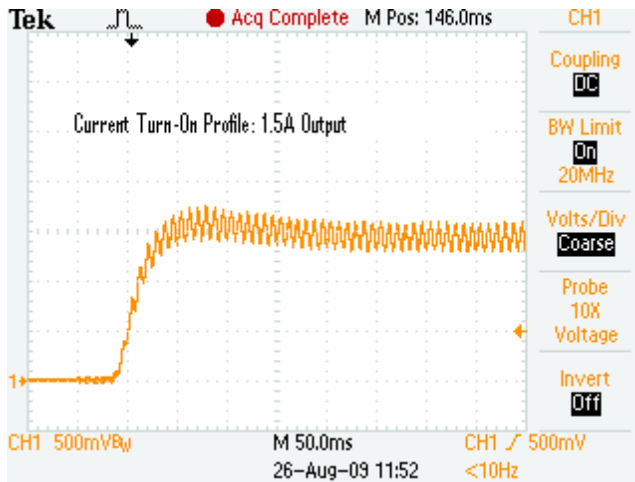

Figure 7. Turn-on Profile; 1.5 A Load

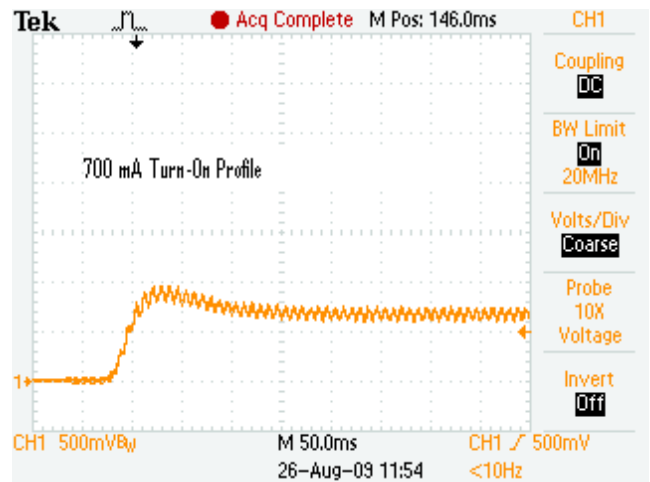

Figure 8. Turn-on Profile; 700 mA Load

Current Regulation with V_{out} Compliance Voltage

Figure 9 shows the output current regulation with respect to the output voltage compliance range which simulates different total V_f levels for series strings of LEDs. This total

forward voltage drop can vary depending on number of LEDs in series, LED binning, LED color (die type), nominal operating dc current level, and ambient temperature. As can be seen in the plot, the current regulation is very tight.

AND8427/D

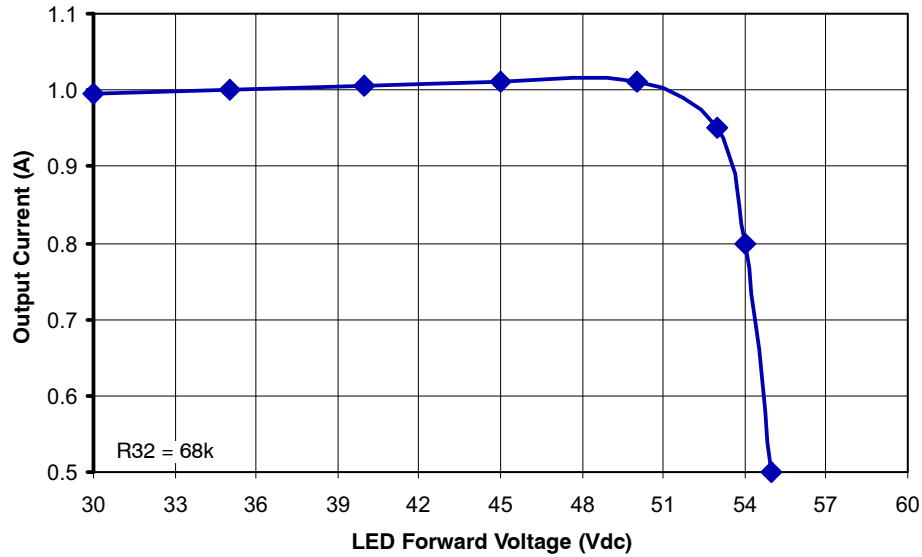

Figure 9. Current Regulation versus Vf Output Compliance Voltage

Final Comments

This compact single stage power factor corrected constant current LED driver is ideal for general and architectural lighting. With minor changes to resistors (R32 and R34) in the secondary control circuit, the regulated current and voltage can be adjusted to meet the specific applications requirements of the end product. The transformer and power

components have been sized for 305 Vac operation. The only components that would need to be changed to support 277 Vac (305 Vac max) are the “X” capacitors C1 and C2 in the primary circuitry and secondary side output rectifier D8 changed to a higher PRV rated device such as the MUR1660CTG or the MURH860CTG.

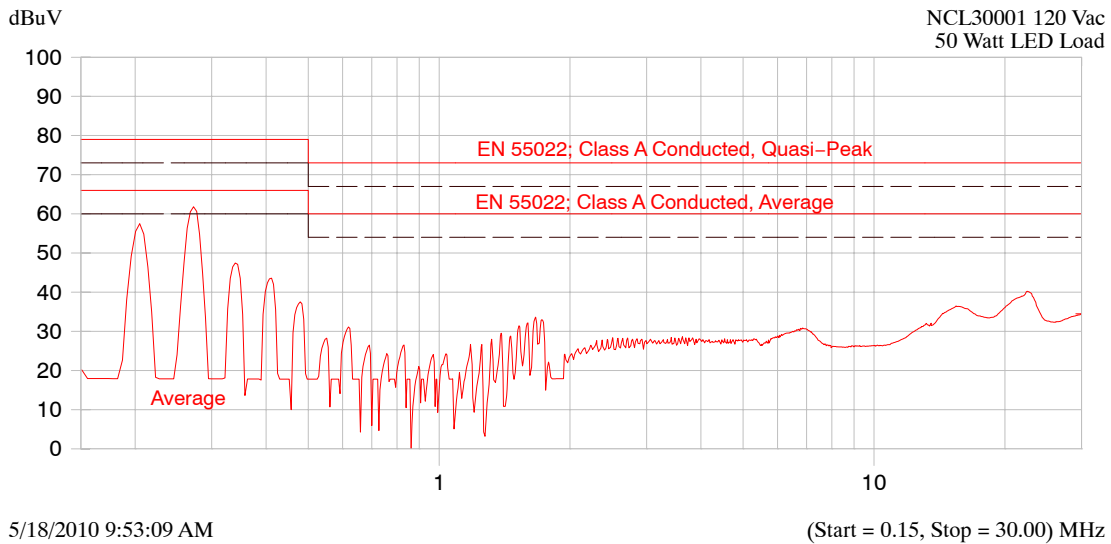

Figure 10. Conducted EMI Plot (average) – 50 Watt Load

AND8427/D

BILL OF MATERIALS

Designator	Qty	Description	Value	Tolerance	Footprint	Manufacturer	Manufacturer Part Number
D5, D10	2	Diode			SMA	ON Semiconductor	MRA4007T
D1, D2, D3, D4	4	Diode			axial lead	ON Semiconductor	1N5406
D6, D7	2	Ultrafast diode			SMB	ON Semiconductor	MURS160
D9, 11, 12, 13	4	Signal diode			SOD123	ON Semiconductor	MMSD4148A
D8	1	UFR diode			TO-220AB CT	ON Semiconductor	MURH860CTG
Z1	1	TVS	Input transient option		axial lead		1.5KE440A
Z3, 4, 5	3	Zener diode	15 V	5%	SOD123	ON Semiconductor	MMSZ5245B
Z2	-	Zener diode	Not Used	5%	SOD123	ON Semiconductor	-
Q5	1	MOSFET	40 V, 100 mA		SOT23	ON Semiconductor	2N7002KT1G
Q7	1	MOSFET	100 V, A		DPak4	ON Semiconductor	NTD12N10T4G
Q1	1	MOSFET	11 A, 800 V		TO-220	Infineon	SPP11N80C3
Q2, Q3, Q6	3	BJT	60 V, 500 mA		SOT23	ON Semiconductor	MMBTA06LT1G
Q4	1	BJT	100 V, 4 A		DPak4	ON Semiconductor	MJD243G
U1	1	PFC controller			SOIC16	ON Semiconductor	NCL30001
U2	1	Optocoupler			4 pin SMD	Vishay	H11A817 or SFH6156A-4
U3	1	Dual amp + zener			SOIC-8	ON Semiconductor	NCS1002
C1, C2	2	X caps	0.47 μ F, 277 V	10%	LS=15mm	Evox Rifa/Kemet or EPCOS	PHE840MB6470MB16R17 or B32922C3474M
C27	1	Y2 cap	2.2 nF, 1 kV	10%	LS=10mm	Evox Rifa/Kemet	PME271Y422M or P271HE222M250A
C3	1	Polyprop. Film	0.22 μ F (630V)	10%	LS=24mm	Vishay	2222 383 20224
C7	1	Disc cap	68 to 100 nF, 400V	10%	LS=10mm	TDK	FK22X7R2J104K
C8, 15, 16, 25, C26, C29, C33	7	ceramic cap	0.1 μ F, 50 V	10%	1206	TDK	C3216X7R2A104K
C23, C24	2	ceramic cap	0.1 μ F, 100 V	10%	1206/1210	TDK	C3216X7R2A104K
C28, C30	2	ceramic cap	1.0 μ F, 25 V	10%	1206	TDK	C3216X7R1H105K
C19	1	ceramic disc cap	1 nF, 1 kV	10%	LS = 8 mm	TDK	CK45-B3AD102KYNN
C12	1	ceramic cap	470 pF, 50 V	10%	1206	Vishay	VJ1206A471JXACW1BC
C9	1	ceramic cap	680 pF, 50 V	10%	1206	Kemet	C1206C681K5GACTU
C10, C18, C31	3	ceramic cap	1 nF, 100 V	10%	1206	Kemet	C1206C102K1RACTU
C14, C17, C32	3	ceramic cap	10 nF, 50 V	10%	1206	TDK	C3216COG2A103J
C13	1	ceramic cap	33 nF, 50 V	10%	1206	TDK	C3216COG1H333J
C5	1	electrolytic cap	100 μ F, 35 V	10%	LS=2.5mm	UCC	ESMG350ELL101MF11D
C11	1	electrolytic cap	4.7 μ F, 25 V	10%	LS=2.5mm	UCC	ESMG250ELL4R7ME11D
C6	1	electrolytic cap	220 μ F, 50 V	10%	LS = 5mm	UCC	ESMG500ELL221MJC5S
C20, 21, 22	3	electrolytic cap	1000 μ F, 63 V	10%	LS = 8 mm	Nichicon	647-UVR1J102MHD
C4	1	electrolytic cap	22 μ F, 450 V	10%	LS = 5 mm	Nichicon	647-UVY2W220MHD
C34, C35	2	ceramic cap	0.1 μ F, 50 V	0.1	1206	TDK	C3216X7R2A104K
R4	1	0.5W resistor	2.2K	10%	axial lead	Vishay	NFR25H0002201JR500
R1	1	0.5W resistor	1M, 0.5W	10%	axial lead	Vishay	CMF601M0000FHEK

AND8427/D

Designator	Qty	Description	Value	Tolerance	Footprint	Manufacturer	Manufacturer Part Number
R8	1	0.5W resistor	2K, 0.5W	10%	axial lead	Vishay	CMF552K0000FHEB
R2	1	0.5W resistor	560K	10%	axial lead	Vishay	HVR3700005603JR500
R27	1	0.5W resistor	4.7K – 5.0K	5%	1210	Vishay	CRCW12104K70JNEA
R24	1	0.5W resistor	100 ohms	10%	axial lead	Vishay	CMF50100R00FHEB
R20, R26	2	0.5W resistor	0.1 ohms	5%	LS = 18 mm	Ohmite	WNCR10FET
R3	1	3 or 5W resistor	36K to 39K	10%	LS = 30 mm	Ohmite	PR03000203602JAC00
R23	1	0.25W resistor	4.7 ohms	5%	1206	Vishay/Dale	CRCW12064R75F
R5	1	0.25W resistor	220 ohms	5%	1206	Vishay/Dale	CRCW1206220RF
R38	1	0.25W resistor	100 ohms	5%	1206	Vishay/Dale	CRCW1206100RF
R21, 41, 42, 43	4	0.25W resistor	10 ohms	5%	1206	Vishay/Dale	CRCW120610R0F
R15, R28	2	0.25W resistor	2.2K	5%	1206	Vishay/Dale	CRCW12062211F
R31, R36	2	0.25W resistor	2.7K	5%	1206	Vishay/Dale	CRCW12062741F
R29, R30	2	0.25W resistor	43.2K	0.01	1206	Vishay/Dale	
R25	1	0.25W resistor	20K	1%	1206	Vishay/Dale	CRCW12062002F
R32	1	0.25W resistor	68K	1%	1206	Vishay/Dale	CRCW12066812F
R33	1	0.25W resistor	6.2K	1%	1206	Vishay/Dale	CRCW12066191F
R37	1	0.25W resistor	5.1K	1%	1206	Vishay/Dale	CRCW12065111F
R34	1	0.25W resistor	82K	1%	1206	Vishay/Dale	CRCW12068252F
R35	1	0.25W resistor	3.9K	1%	1206	Vishay/Dale	CRCW12063921F
R14, 22, 39, 40	4	0.25W resistor	10K	1%	1206	Vishay/Dale	CRCW12061002F
R13	1	0.25W resistor	7.32K	1%	1206	Vishay/Dale	CRCW12064322F
R9, R12	2	0.25W resistor	30.1K	1%	1206	Vishay/Dale	CRCW12063012F
R17	1	0.25W resistor	56K	1%	1206	Vishay/Dale	CRCW12065622F
R18	1	0.25W resistor	49.9K	1%	1206	Vishay/Dale	CRCW12064992F
R19	1	0.25W resistor	76.8K	1%	1206	Vishay/Dale	CRCW12067682F
R16	1	0.25W resistor	100K	1%	1206	Vishay/Dale	CRCW12061003F
R10	1	0.25W resistor	332K	1%	1206	Vishay/Dale	CRCW12063323F
R6, 7, 11	3	0.25W resistor	365K	1%	1206	Vishay/Dale	CRCW12063653F
F1	1	Fuse	2.5A, 250Vac		TR-5	Littlefuse	37212500411
L1A/B	2	EMI inductor			Slug core	Coilcraft	PCV-0224-03L
L2	1	EMI inductor			Toroid	Coilcraft	P3220-AL
T1	1	Flyback xfmr	55V, 90W CCM		custom	WE-Midcom (Würth Electronics)	750311267, Rev 01
J1, J2, J3	3	I/O connectors			LS = 5 mm	Weidmuller	1716020000
(for Q1, D8)	2	Heatsink Q1, D8			LS = 25.4 mm	Aavid	531102B02500G (or similar)
HD1	1	Header	CONN HEADER 2POS		0.100"	Molex	90120-0122
JMP1	1	Shorting Jumper	0.1" Two Position Shorting Jumper		0.100"	Sullins Connector Solutions	SPC02SYAN

AND8427/D

Designator	Qty	Description	Value	Tolerance	Footprint	Manufacturer	Manufacturer Part Number
------------	-----	-------------	-------	-----------	-----------	--------------	--------------------------

Optional DIM Daughter Card BOM

D1, D2, D3	3	Signal diode			SOD123	ON Semiconductor	MMSD4148A
Q1	1	BJT	400mA, 40V		SOT23	ON Semiconductor	MMBT2222A
Q2	1	Mosfet	40V, 100 mA		SOT23	ON Semiconductor	2N7002KT1G
U1	1	Timer IC	_		SOIC8	ON Semiconductor	MC1455D
U2	1	Quad Opamp	_		SOIC14	ON Semiconductor	LM324DG
C4	1	ceramic cap	1.0 μ F, 25V	10%	1206	TDK	C3216X7R1H105K
C1	1	ceramic cap	68 nF, 50V	10%	1206	Vishay	VJ1206Y683KXAA
C2, 3, 7, 9	4	ceramic cap	0.1 μ F, 50V	10%	1206	TDK	C3216X7R2A104K
C6, C8	2	ceramic cap	10 nF, 50V	10%	1206	TDK	C3216COG2A103J
C5	1	ceramic cap	1 nF, 100V	10%	1206	Kemet	C1206C102K1RACTU
R1	1	potentiometer	20K, 15 Turn		Thru hole	Vishay	T18203KT10
R9	1	potentiometer	100K, 15 turn		Thru hole	Vishay	T18104KT10
R4, 11, 13, 16	4	0.25W resistor	10K	5%	1206	Vishay/Dale	CRCW12061002F
R2	1	0.25W resistor	150K	1%	1206	Vishay/Dale	CRCW12061503F
R3	1	0.25W resistor	20K	1%	1206	Vishay/Dale	CRCW12062002F
R5	1	0.25W resistor	4.3K	1%	1206	Vishay/Dale	CRCW12064321F
R6	1	0.25W resistor	5K	1%	1206	Vishay/Dale	CRCW12064991F
R7	1	0.25W resistor	1.0K	1%	1206	Vishay/Dale	CRCW12061001F
R8	1	0.25W resistor	15K	1%	1206	Vishay/Dale	CRCW12061502F
R10	1	0.25W resistor	11K	1%	1206	Vishay/Dale	CRCW12061102F
R12	1	0.25W resistor	30K	1%	1206	Vishay/Dale	CRCW12063012F
R15	1	0.25W resistor	10 ohms	1%	1206	Vishay/Dale	CRCW120610R0F
R14	1	0.25W resistor	Zero ohms	1%	1206	Vishay/Dale	CRCW12060000Z
TH1	1	PTC Thermistor	Not Used		Thru hole		
CON 1	1	right angle pins	0.1" 6 position		Thru hole	Molex or Tyco	Rt angle 6 pin connector, 0.1" pitch

AND8427/D

REFERENCES

ON Semiconductor Application Note AND8397
ON Semiconductor Data Sheet for NCL30001
ON Semiconductor Data Sheet for NCS1002

XLamp is a trademark of Cree, Inc.

ON Semiconductor and  are registered trademarks of Semiconductor Components Industries, LLC (SCILLC). SCILLC reserves the right to make changes without further notice to any products herein. SCILLC makes no warranty, representation or guarantee regarding the suitability of its products for any particular purpose, nor does SCILLC assume any liability arising out of the application or use of any product or circuit, and specifically disclaims any and all liability, including without limitation special, consequential or incidental damages. "Typical" parameters which may be provided in SCILLC data sheets and/or specifications can and do vary in different applications and actual performance may vary over time. All operating parameters, including "Typicals" must be validated for each customer application by customer's technical experts. SCILLC does not convey any license under its patent rights nor the rights of others. SCILLC products are not designed, intended, or authorized for use as components in systems intended for surgical implant into the body, or other applications intended to support or sustain life, or for any other application in which the failure of the SCILLC product could create a situation where personal injury or death may occur. Should Buyer purchase or use SCILLC products for any such unintended or unauthorized application, Buyer shall indemnify and hold SCILLC and its officers, employees, subsidiaries, affiliates, and distributors harmless against all claims, costs, damages, and expenses, and reasonable attorney fees arising out of, directly or indirectly, any claim of personal injury or death associated with such unintended or unauthorized use, even if such claim alleges that SCILLC was negligent regarding the design or manufacture of the part. SCILLC is an Equal Opportunity/Affirmative Action Employer. This literature is subject to all applicable copyright laws and is not for resale in any manner.

PUBLICATION ORDERING INFORMATION

LITERATURE FULFILLMENT:

Literature Distribution Center for ON Semiconductor
P.O. Box 5163, Denver, Colorado 80217 USA
Phone: 303-675-2175 or 800-344-3860 Toll Free USA/Canada
Fax: 303-675-2176 or 800-344-3867 Toll Free USA/Canada
Email: orderlit@onsemi.com

N. American Technical Support: 800-282-9855 Toll Free
USA/Canada
Europe, Middle East and Africa Technical Support:
Phone: 421 33 790 2910
Japan Customer Focus Center
Phone: 81-3-5773-3850

ON Semiconductor Website: www.onsemi.com
Order Literature: <http://www.onsemi.com/orderlit>
For additional information, please contact your local
Sales Representative