



LM78XX

LINEAR INTEGRATED CIRCUIT

3-TERMINAL 1A POSITIVE VOLTAGE REGULATOR

DESCRIPTION

The UTC **LM78XX** family is monolithic fixed voltage regulator integrated circuit. They are suitable for applications that required supply current up to 1 A.

FEATURES

- * Output current up to 1A
- * Fixed output voltage of 5V, 6V, 7V, 8V, 9V, 10V, 12V, 15V and 18V available
- * Thermal overload shutdown protection
- * Short circuit current limiting
- * Output transistor SOA protection

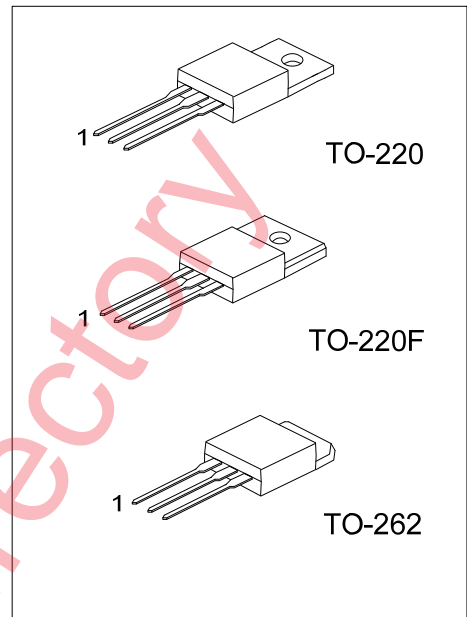

ORDERING INFORMATION

Ordering Number		Package	Pin Assignment			Packing
Lead Free	Halogen Free		1	2	3	
LM78XXL-TA3-T	LM78XXG-TA3-T	TO-220	I	G	O	Tube
LM78XXL-TF3-T	LM78XXG-TF3-T	TO-220F	I	G	O	Tube
LM78XXL-T2Q-T	LM78XXG-T2Q-T	TO-262	I	G	O	Tube

Note: Pin Assignment: O: Output G: GND I: Input

<p>LM78XXL-TA3-T</p>	<p>(1) T: Tube</p> <p>(2) TA3: TO-220, TF3: TO-220F, T2Q: TO-262</p> <p>(3) G: Halogen Free, L: Lead Free</p> <p>(4) XX: refer to Marking Information</p>
----------------------	---

MARKING INFORMATION

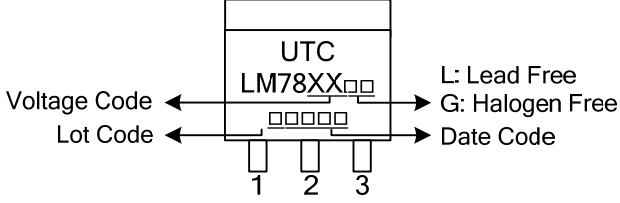
PACKAGE	VOLTAGE CODE	MARKING
TO-220 TO-220F TO-262	05: 5.0 V 06: 6.0 V 07: 7.0 V 08: 8.0 V 09: 9.0 V 10: 10 V 12: 12 V 15: 15 V 18: 18 V	

■ TEST CIRCUIT

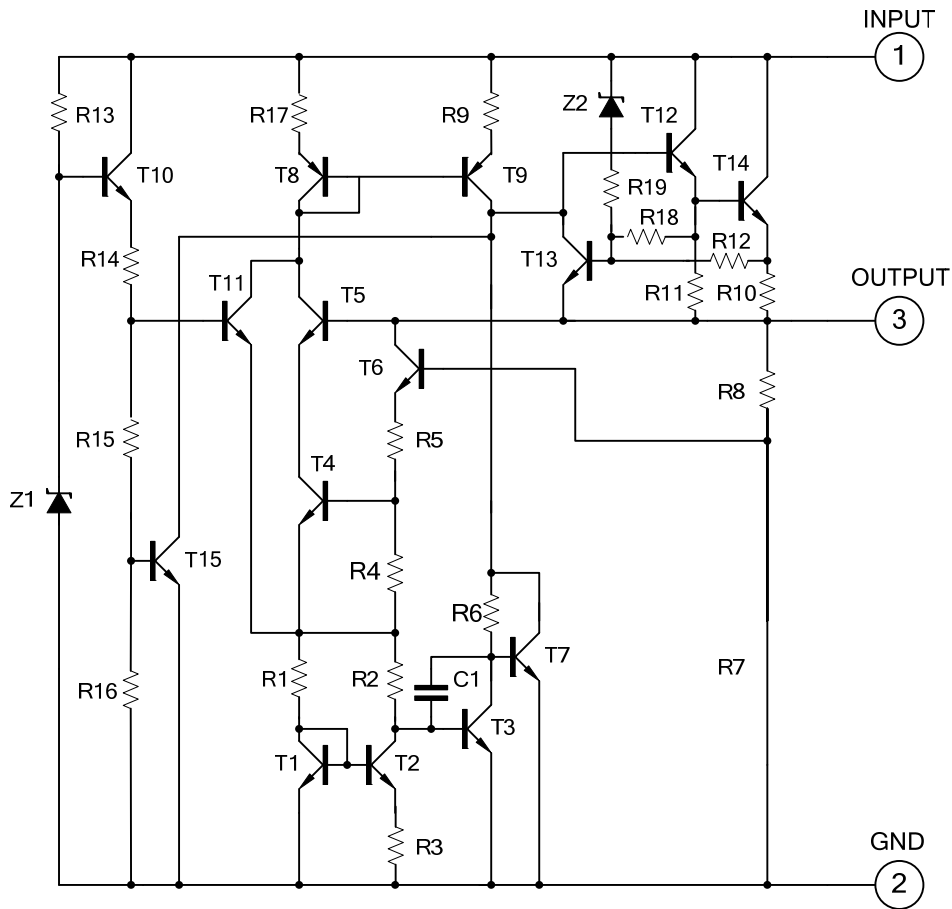

■ APPLICATION CIRCUIT

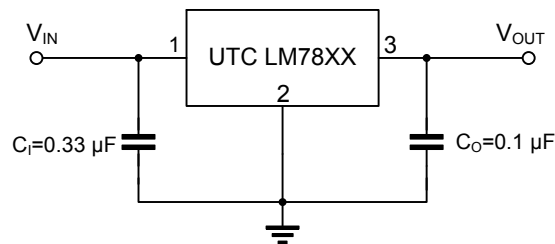

Note 1: To specify an output voltage, substitute voltage value for "XX".

2: Bypass capacitors are recommended for optimum stability and transient response and should be located as close as possible to the regulators.

■ ABSOLUTE MAXIMUM RATINGS (Operating temperature range applies unless otherwise specified)

PARAMETER	SYMBOL	RATING	UNIT
Input voltage	V_{IN}	35	V
Output Current	I_{OUT}	1	A
Power Dissipation	P_D	Internally Limited	W
Operating Junction Temperature	T_{OPR}	-20 ~ +150	°C
Storage Temperature	T_{STG}	-55 ~ +150	°C

Note: Absolute maximum ratings are those values beyond which the device could be permanently damaged. Absolute maximum ratings are stress ratings only and functional device operation is not implied.

■ THERMAL DATA

PARAMETER	SYMBOL	RATING	UNIT
Junction to Ambient	θ_{JA}	65	°C/W
Junction to Case	θ_{JC}	5	°C/W

■ ELECTRICAL CHARACTERISTICS

($I_{OUT}=0.5A$, $T_J=0^{\circ}C\sim 125^{\circ}C$, $C_I=0.33\mu F$, $C_O=0.1\mu F$, unless otherwise specified)(Note 1)

For UTC LM7805 ($V_{IN}=10V$)

PARAMETER	SYMBOL	TEST CONDITIONS	MIN	TYP	MAX	UNIT
Output Voltage	V_{OUT}	$T_J=25^{\circ}C$, $I_{OUT}=5mA \sim 1.0A$	4.80	5.0	5.20	V
		$V_{IN}=7.5V \sim 20V$, $I_{OUT}=5mA \sim 1.0A$, $P_D \leq 15W$	4.75		5.25	V
Dropout Voltage	V_D	$T_J=25^{\circ}C$		2.0		V
Load Regulation	ΔV_{OUT}	$T_J=25^{\circ}C$, $I_{OUT}=5mA \sim 1.0A$			50	mV
		$T_J=25^{\circ}C$, $I_{OUT}=0.25A \sim 0.75A$			25	mV
Line regulation	ΔV_{OUT}	$V_{IN}=7V \sim 25V$, $T_J=25^{\circ}C$			50	mV
		$V_{IN}=7.5V \sim 20V$, $T_J=25^{\circ}C$, $I_{OUT}=1.0A$			50	mV
Quiescent Current	I_Q	$T_J=25^{\circ}C$, $I_{OUT} \leq 1.0A$			8.0	mA
Quiescent Current Change	ΔI_Q	$V_{IN}=7.5V \sim 20V$			1.0	mA
		$I_{OUT}=5mA \sim 1.0A$			0.5	mA
Output Noise Voltage	eN	$10Hz \leq f \leq 100kHz$		40		μV
Temperature Coefficient of V_o	$\Delta V_o/\Delta T$	$I_{OUT}=5mA$		-0.6		mV/°C
Ripple Rejection	RR	$V_{IN}=8V \sim 18V$, $f=120Hz$, $T_J=25^{\circ}C$	62	80		dB
Peak Output Current	I_{PEAK}	$T_J=25^{\circ}C$		1.8		A
Short-Circuit Current	I_{SC}	$V_{IN}=35V$, $T_J=25^{\circ}C$		250		mA

■ ELECTRICAL CHARACTERISTICS(Cont.)

For UTC LM7806 ($V_{IN}=11V$)

PARAMETER	SYMBOL	TEST CONDITIONS	MIN	TYP	MAX	UNIT
Output Voltage	V_{OUT}	$T_J=25^{\circ}C, I_{OUT}=5mA \sim 1.0A$	5.76	6.0	6.24	V
		$V_{IN}=8.5V \sim 21V,$ $I_{OUT}=5mA \sim 1.0A, P_D \leq 15W$	5.70		6.30	V
Dropout Voltage	V_D	$T_J=25^{\circ}C$		2.0		V
Load Regulation	ΔV_{OUT}	$T_J=25^{\circ}C, I_{OUT}=5mA \sim 1.0A$			60	mV
		$T_J=25^{\circ}C, I_{OUT}=0.25A \sim 0.75A$			30	mV
Line regulation	ΔV_{OUT}	$V_{IN}=8V \sim 25V, T_J=25^{\circ}C$			60	mV
		$V_{IN}=8.5V \sim 21V, T_J=25^{\circ}C, I_{OUT}=1.0A$			60	mV
Quiescent Current	I_Q	$T_J=25^{\circ}C, I_{OUT} \leq 1.0A$			8.0	mA
Quiescent Current Change	ΔI_Q	$V_{IN}=8.5V \sim 21V$			1.0	mA
		$I_{OUT}=5mA \sim 1.0A$			0.5	mA
Output Noise Voltage	eN	$10Hz \leq f \leq 100kHz$		45		μV
Temperature Coefficient of V_o	$\Delta V_o/\Delta T$	$I_{OUT}=5mA$		-0.7		$mV/^{\circ}C$
Ripple Rejection	RR	$V_{IN}=9V \sim 19V, f=120Hz, T_J=25^{\circ}C$	59	75		dB
Peak Output Current	I_{PEAK}	$T_J=25^{\circ}C$		1.8		A
Short-Circuit Current	I_{SC}	$V_{IN}=35V, T_J=25^{\circ}C$		250		mA

For UTC LM7807 ($V_{IN}=13V$)

PARAMETER	SYMBOL	TEST CONDITIONS	MIN	TYP	MAX	UNIT
Output Voltage	V_{OUT}	$T_J=25^{\circ}C, I_{OUT}=5mA - 1.0A$	6.72	7.0	7.28	V
		$V_{IN}=9.5V \sim 22V,$ $I_{OUT}=5mA \sim 1.0A, P_D \leq 15W$	6.65		7.35	V
Dropout Voltage	V_D	$T_J=25^{\circ}C$		2.0		V
Load Regulation	ΔV_{OUT}	$T_J=25^{\circ}C, I_{OUT}=5mA \sim 1.0A$			70	mV
		$T_J=25^{\circ}C, I_{OUT}=0.25A \sim 0.75A$			35	mV
Line regulation	ΔV_{OUT}	$V_{IN}=9V \sim 25V, T_J=25^{\circ}C$			70	mV
		$V_{IN}=9.5V \sim 22V, T_J=25^{\circ}C, I_{OUT}=1.0A$			70	mV
Quiescent Current	I_Q	$T_J=25^{\circ}C, I_{OUT} \leq 1.0A$			8.0	mA
Quiescent Current Change	ΔI_Q	$V_{IN}=9.5V \sim 22V$			1.0	mA
		$I_{OUT}=5mA \sim 1.0A$			0.5	mA
Output Noise Voltage	eN	$10Hz \leq f \leq 100kHz$		50		μV
Temperature Coefficient of V_o	$\Delta V_o/\Delta T$	$I_{OUT}=5mA$		-0.8		$mV/^{\circ}C$
Ripple Rejection	RR	$V_{IN}=10V \sim 20V, f=120Hz, T_J=25^{\circ}C$	59	75		dB
Peak Output Current	I_{PEAK}	$T_J=25^{\circ}C$		1.7		A
Short-Circuit Current	I_{SC}	$V_{IN}=35V, T_J=25^{\circ}C$		250		mA

■ ELECTRICAL CHARACTERISTICS(Cont.)

For UTC LM7808 ($V_{IN}=14V$)

PARAMETER	SYMBOL	TEST CONDITIONS	MIN	TYP	MAX	UNIT
Output Voltage	V_{OUT}	$T_J=25^{\circ}C, I_{OUT}=5mA \sim 1.0A$	7.68	8.0	8.32	V
		$V_{IN}=10.5V \sim 23V,$ $I_{OUT}=5mA \sim 1.0A, P_D \leq 15W$	7.60		8.40	V
Dropout Voltage	V_D	$T_J=25^{\circ}C$		2.0		V
Load Regulation	ΔV_{OUT}	$T_J=25^{\circ}C, I_{OUT}=5mA \sim 1.0A$			80	mV
		$T_J=25^{\circ}C, I_{OUT}=0.25A \sim 0.75A$			40	mV
Line regulation	ΔV_{OUT}	$V_{IN}=10.5V \sim 25V, T_J=25^{\circ}C$			80	mV
		$V_{IN}=10.5V \sim 23V, T_J=25^{\circ}C, I_{OUT}=1.0A$			80	mV
Quiescent Current	I_Q	$T_J=25^{\circ}C, I_{OUT} \leq 1.0A$			8.0	mA
Quiescent Current Change	ΔI_Q	$V_{IN}=10.5V \sim 23V$			1.0	mA
		$I_{OUT}=5mA \sim 1.0A$			0.5	mA
Output Noise Voltage	eN	$10Hz \leq f \leq 100kHz$		58		μV
Temperature Coefficient of V_o	$\Delta V_o/\Delta T$	$I_{OUT}=5mA$		-0.9		$mV/^{\circ}C$
Ripple Rejection	RR	$V_{IN}=11.5V \sim 21.5V,$ $f=120Hz, T_J=25^{\circ}C$	56	72		dB
Peak Output Current	I_{PEAK}	$T_J=25^{\circ}C$		1.8		A
Short-Circuit Current	I_{SC}	$V_{IN}=35V, T_J=25^{\circ}C$		250		mA

For UTC LM7809 ($V_{IN}=15V$)

PARAMETER	SYMBOL	TEST CONDITIONS	MIN	TYP	MAX	UNIT
Output Voltage	V_{OUT}	$T_J=25^{\circ}C, I_{OUT}=5mA \sim 1.0A$	8.64	9.0	9.36	V
		$V_{IN}=11.5V \sim 24V,$ $I_{OUT}=5mA \sim 1.0A, P_D \leq 15W$	8.55		9.45	V
Dropout Voltage	V_D	$T_J=25^{\circ}C$		2.0		V
Load Regulation	ΔV_{OUT}	$T_J=25^{\circ}C, I_{OUT}=5mA \sim 1.0A$			90	mV
		$T_J=25^{\circ}C, I_{OUT}=0.25A \sim 0.75A$			45	mV
Line regulation	ΔV_{OUT}	$V_{IN}=11.5V \sim 25V, T_J=25^{\circ}C$			90	mV
		$V_{IN}=11.5V \sim 24V, T_J=25^{\circ}C, I_{OUT}=1.0A$			90	mV
Quiescent Current	I_Q	$T_J=25^{\circ}C, I_{OUT} \leq 1.0A$			8.0	mA
Quiescent Current Change	ΔI_Q	$V_{IN}=11.5V \sim 24V$			1.0	mA
		$I_{OUT}=5mA \sim 1.0A$			0.5	mA
Output Noise Voltage	eN	$10Hz \leq f \leq 100kHz$		58		μV
Temperature Coefficient of V_o	$\Delta V_o/\Delta T$	$I_{OUT}=5mA$		-1.1		$mV/^{\circ}C$
Ripple Rejection	RR	$V_{IN}=12.5V \sim 22.5V, f=120Hz, T_J=25^{\circ}C$	56	72		dB
Peak Output Current	I_{PEAK}	$T_J=25^{\circ}C$		1.8		A
Short-Circuit Current	I_{SC}	$V_{IN}=35V, T_J=25^{\circ}C$		250		mA

■ ELECTRICAL CHARACTERISTICS(Cont.)

For UTC LM7810 ($V_{IN} = 16V$)

PARAMETER	SYMBOL	TEST CONDITIONS	MIN	TYP	MAX	UNIT
Output Voltage	V_{OUT}	$T_J = 25^\circ C, I_{OUT} = 5mA \sim 1.0A$	9.60	10.0	10.40	V
		$V_{IN} = 12.5V \sim 25V,$ $I_{OUT} = 5mA \sim 1.0A, P_D \leq 15W$	9.50		10.50	V
Dropout Voltage	V_D	$T_J = 25^\circ C$		2.0		V
Load Regulation	ΔV_{OUT}	$T_J = 25^\circ C, I_{OUT} = 5mA - 1.0A$			100	mV
		$T_J = 25^\circ C, I_{OUT} = 0.25A - 0.75A$			50	mV
Line regulation	ΔV_{OUT}	$V_{IN} = 13V \sim 25V, T_J = 25^\circ C$			100	mV
		$V_{IN} = 13V \sim 25V, T_J = 25^\circ C, I_{OUT} = 1.0A$			100	mV
Quiescent Current	I_Q	$T_J = 25^\circ C, I_{OUT} \leq 1.0A$			8.0	mA
Quiescent Current Change	ΔI_Q	$V_{IN} = 12.6V \sim 25V$			1.0	mA
		$I_{OUT} = 5mA - 1.0A$			0.5	mA
Output Noise Voltage	eN	$10Hz \leq f \leq 100kHz$		58		μV
Temperature coefficient of V_o	$\Delta V_o / \Delta T$	$I_{OUT} = 5mA$		-1.1		mV/ $^\circ C$
Ripple Rejection	RR	$V_{IN} = 13V \sim 23V, f = 120Hz, T_J = 25^\circ C$	56	72		dB
Peak Output Current	I_{PEAK}	$T_J = 25^\circ C$		1.8		A
Short-Circuit Current	I_{SC}	$V_{IN} = 35V, T_J = 25^\circ C$		250		mA

For UTC LM7812 ($V_{IN} = 19V$)

PARAMETER	SYMBOL	TEST CONDITIONS	MIN	TYP	MAX	UNIT
Output Voltage	V_{OUT}	$T_J = 25^\circ C, I_{OUT} = 5mA \sim 1.0A$	11.52	12.0	12.48	V
		$V_{IN} = 14.5V \sim 27V,$ $I_{OUT} = 5mA \sim 1.0A, P_D \leq 15W$	11.40		12.60	V
Dropout Voltage	V_D	$T_J = 25^\circ C$		2.0		V
Load Regulation	ΔV_{OUT}	$T_J = 25^\circ C, I_{OUT} = 5mA \sim 1.0A$			120	mV
		$T_J = 25^\circ C, I_{OUT} = 0.25A \sim 0.75A$			60	mV
Line regulation	ΔV_{OUT}	$V_{IN} = 14.5V \sim 30V, T_J = 25^\circ C$			120	mV
		$V_{IN} = 14.6V \sim 27V, T_J = 25^\circ C, I_{OUT} = 1.0A$			120	mV
Quiescent Current	I_Q	$T_J = 25^\circ C, I_{OUT} \leq 1.0A$			8.0	mA
Quiescent Current Change	ΔI_Q	$V_{IN} = 14.5V \sim 30V$			1.0	mA
		$I_{OUT} = 5mA \sim 1.0A$			0.5	mA
Output Noise Voltage	eN	$10Hz \leq f \leq 100kHz$		75		μV
Temperature Coefficient of V_o	$\Delta V_o / \Delta T$	$I_{OUT} = 5mA$		-1.5		mV/ $^\circ C$
Ripple Rejection	RR	$V_{IN} = 15V - 25V, f = 120Hz, T_J = 25^\circ C$	55	72		dB
Peak Output Current	I_{PEAK}	$T_J = 25^\circ C$		1.8		A
Short-Circuit Current	I_{SC}	$V_{IN} = 35V, T_J = 25^\circ C$		250		mA

■ ELECTRICAL CHARACTERISTICS(Cont.)

For UTC LM7815 ($V_{IN} = 23V$)

PARAMETER	SYMBOL	TEST CONDITIONS	MIN	TYP	MAX	UNIT
Output Voltage	V_{OUT}	$T_J = 25^\circ C, I_{OUT} = 5mA \sim 1.0A$	14.40	15.0	15.60	V
		$V_{IN} = 17.5V \sim 30V,$ $I_{OUT} = 5mA \sim 1.0A, P_D \leq 15W$	14.25		15.75	V
Dropout Voltage	V_D	$T_J = 25^\circ C$		2.0		V
Load Regulation	ΔV_{OUT}	$T_J = 25^\circ C, I_{OUT} = 5mA \sim 1.0A$			150	mV
		$T_J = 25^\circ C, I_{OUT} = 0.25A \sim 0.75A$			75	mV
Line regulation	ΔV_{OUT}	$V_{IN} = 18.5V \sim 30V, T_J = 25^\circ C$			150	mV
		$V_{IN} = 17.7V \sim 30V, T_J = 25^\circ C, I_{OUT} = 1.0A$			150	mV
Quiescent Current	I_Q	$T_J = 25^\circ C, I_{OUT} \leq 1.0A$			8.0	mA
Quiescent Current Change	ΔI_Q	$V_{IN} = 17.5V \sim 30V$			1.0	mA
		$I_{OUT} = 5mA \sim 1.0A$			0.5	mA
Output Noise Voltage	eN	$10Hz \leq f \leq 100kHz$		90		μV
Temperature Coefficient of V_o	$\Delta V_o / \Delta T$	$I_{OUT} = 5mA$		-1.8		$mV/^\circ C$
Ripple Rejection	RR	$V_{IN} = 18.5V \sim 28.5V, f = 120Hz, T_J = 25^\circ C$	54	70		dB
Peak Output Current	I_{PEAK}	$T_J = 25^\circ C$		1.8		A
Short-Circuit Current	I_{SC}	$V_{IN} = 35V, T_J = 25^\circ C$		250		mA

For UTC LM7818 ($V_{IN} = 27V$)

PARAMETER	SYMBOL	TEST CONDITIONS	MIN	TYP	MAX	UNIT
Output Voltage	V_{OUT}	$T_J = 25^\circ C, I_{OUT} = 5mA \sim 1.0A$	17.28	18.0	18.72	V
		$V_{IN} = 21V \sim 33V,$ $I_{OUT} = 5mA \sim 1.0A, P_D \leq 15W$	17.10		18.90	V
Dropout Voltage	V_D	$T_J = 25^\circ C$		2.0		V
Load Regulation	ΔV_{OUT}	$T_J = 25^\circ C, I_{OUT} = 5mA \sim 1.0A$			180	mV
		$T_J = 25^\circ C, I_{OUT} = 0.25A \sim 0.75A$			90	mV
Line regulation	ΔV_{OUT}	$V_{IN} = 21V \sim 33V, T_J = 25^\circ C$			180	mV
		$V_{IN} = 21V \sim 33V,$ $T_J = 25^\circ C, I_{OUT} = 1.0A$			180	mV
Quiescent Current	I_Q	$T_J = 25^\circ C, I_{OUT} \leq 1.0A$			8.0	mA
Quiescent Current Change	ΔI_Q	$V_{IN} = 21.5V \sim 33V$			1.0	mA
		$I_{OUT} = 5mA \sim 1.0A$			0.5	mA
Output Noise Voltage	eN	$10Hz \leq f \leq 100kHz$		110		μV
Temperature Coefficient of V_o	$\Delta V_o / \Delta T$	$I_{OUT} = 5mA$		-2.2		$mV/^\circ C$
Ripple Rejection	RR	$V_{IN} = 22V \sim 32V, f = 120Hz, T_J = 25^\circ C$	53	69		dB
Peak Output Current	I_{PEAK}	$T_J = 25^\circ C$		1.8		A
Short-Circuit Current	I_{SC}	$V_{IN} = 35V, T_J = 25^\circ C$		250		mA

Note 1: The Maximum steady state usable output current are dependent on input voltage, heat sinking, lead length of the package and copper pattern of PCB. The data above represents pulse test conditions with junction temperatures specified at the initiation of test.

2: Power dissipation < 0.5W

■ NOTES FOR USE

1. Thermal design

Use a thermal design that allows for a sufficient margin in light of the power dissipation (P_d) in actual operating conditions.

2. Absolute maximum ratings

An excess in the absolute maximum ratings, such as supply voltage, temperature range of operating conditions, etc., can break down the devices, thus making impossible to identify breaking mode, such as a short circuit or an open circuit. If any over rated values will expect to exceed the absolute maximum ratings, consider adding circuit protection devices, such as fuses.

3. GND voltage

The potential of GND pin must be minimum potential in all operating conditions.

4. Actions in strong electromagnetic field

Use caution when using the IC in the presence of a strong electromagnetic field as doing so may cause the IC to malfunction.

5. Inter-pin shorts and mounting errors

Use caution when positioning the IC for mounting on printed circuit boards.

The IC may be damaged if there is any connection error or if pins are shorted together.

6. Thermal shutdown circuit

The IC incorporates a built-in thermal shutdown circuit (TSD circuit). The thermal shutdown circuit (TSD circuit) is designed only to shut the IC off to prevent thermal runaway. It is not designed to protect the IC or guarantee its operation. Do not continue to use the IC after operating this circuit or use the IC in an environment where the operation of this circuit is assumed.

7. Overcurrent Protection Circuit

An overcurrent protection circuit is incorporated in order to prevention destruction due to short-time overload currents.

Continued use of the protection circuits should be avoided. Please note that the current increases negatively impact the temperature.

8. Testing on application boards

When testing the IC on an application board, connecting a capacitor to a pin with low impedance subjects the IC to stress. Always discharge capacitors after each process or step. Always turn the IC's power supply off before connecting it to or removing it from a jig or fixture during the inspection process. Ground the IC during assembly steps as an antistatic measure. Use similar precaution when transporting or storing the IC.

■ NOTES FOR USE(Cont.)

9. Ground Wiring Pattern

When using both small signal and large current GND patterns, it is recommended to isolate the two ground patterns, placing a single ground point at the ground potential of application so that the pattern wiring resistance and voltage variations caused by large currents do not cause variations in the small signal ground voltage. Be careful not to change the GND wiring pattern of any external components, either.

10. Damage to the internal circuit or element may occur when the polarity of the Vcc pin is opposite to that of the other pins in applications. (I.e. Vcc is shorted with the GND pin while an external capacitor is charged.) Use a maximum capacitance of 1000 μ F for the output pins. Inserting a diode to prevent back-current flow in series with Vcc or bypass diodes between Vcc and each pin is recommended.

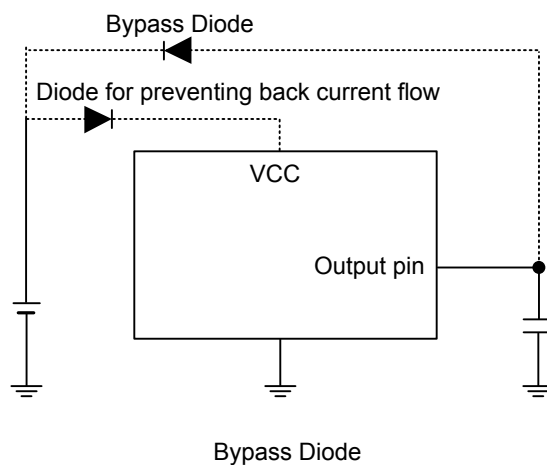

TYPICAL CHARACTERISTICS

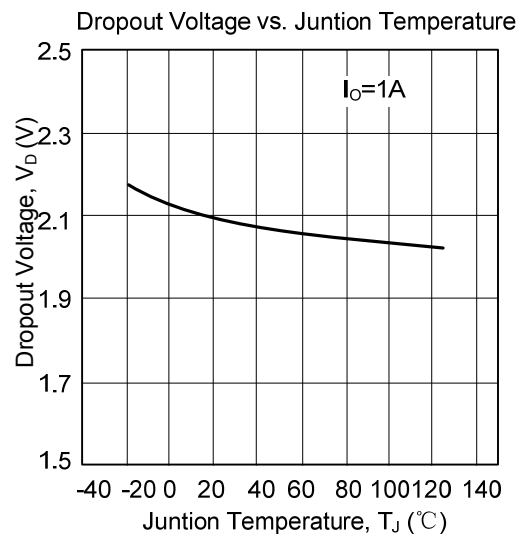
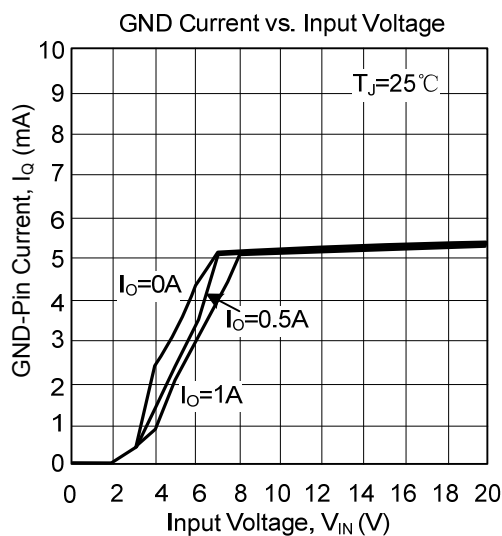
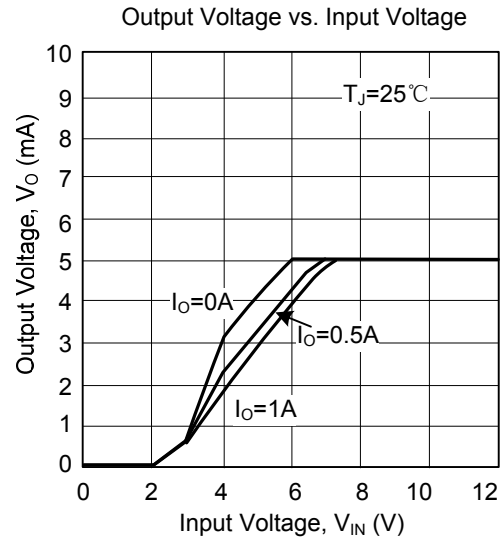
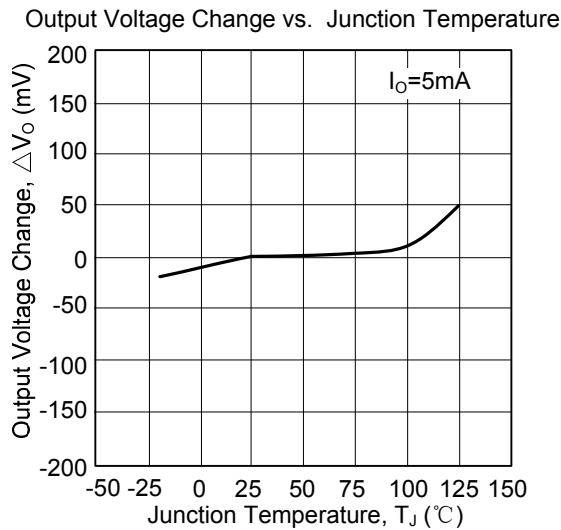
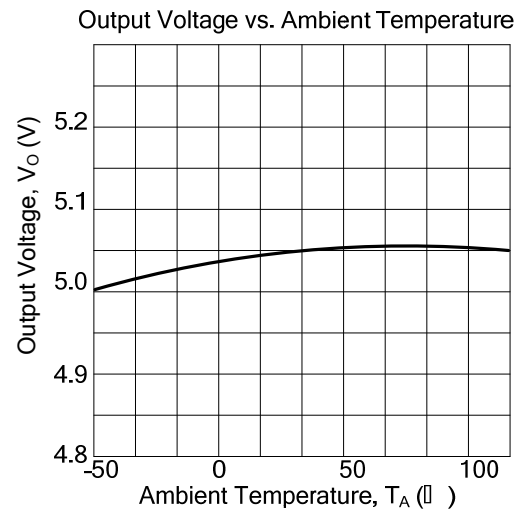
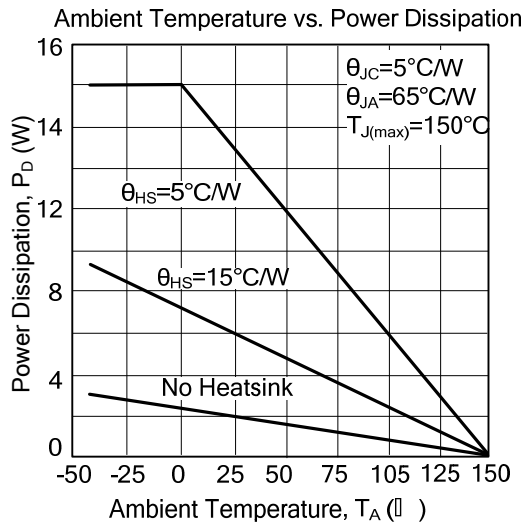

■ TYPICAL CHARACTERISTICS(Cont.)

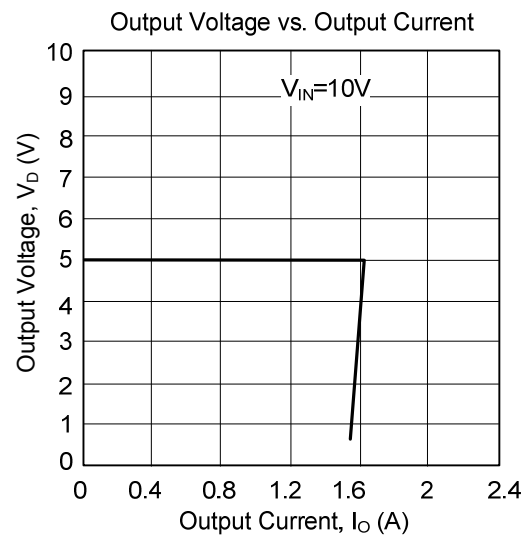
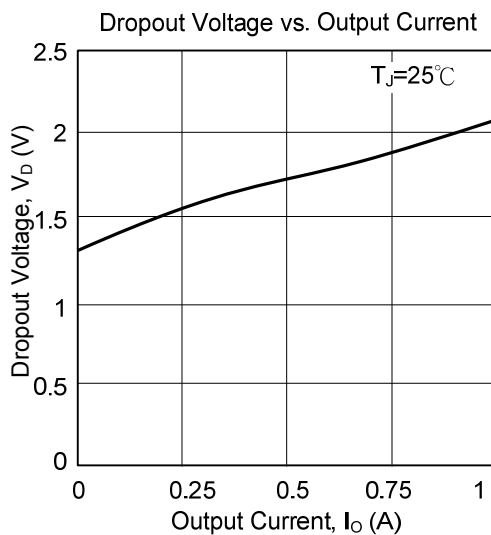
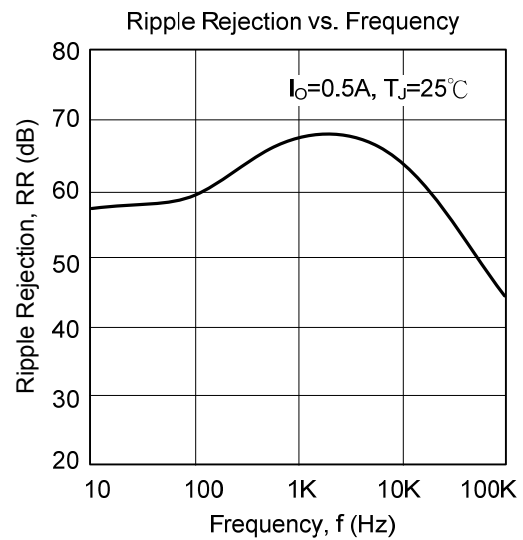
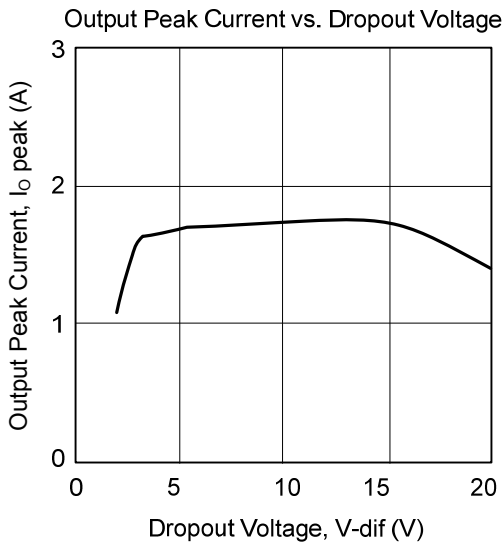

UTC assumes no responsibility for equipment failures that result from using products at values that exceed, even momentarily, rated values (such as maximum ratings, operating condition ranges, or other parameters) listed in products specifications of any and all UTC products described or contained herein. UTC products are not designed for use in life support appliances, devices or systems where malfunction of these products can be reasonably expected to result in personal injury. Reproduction in whole or in part is prohibited without the prior written consent of the copyright owner. The information presented in this document does not form part of any quotation or contract, is believed to be accurate and reliable and may be changed without notice.