

## Glass Passivated Bridge Rectifiers

### FEATURES

- Glass passivated junction
- Integrally molded heatsink provide very low thermal resistance for maximum heat dissipation
- Typical IR less than 0.2μA
- High surge current capability
- UL Recognized File # E-326243
- Compliant to RoHS Directive 2011/65/EU and in accordance to WEEE 2002/96/EC



**GBPC**



**GBPC-W**



**GBPC-M**



### MECHANICAL DATA

**Case:** GBPC

Molding compound, UL flammability classification rating 94V-0

**Terminal:** Matte tin plated leads, solderable per JESD22-B102

Meet JESD 201 class 1A whisker test

**Polarity:** Polarity as marked on the body

**Mounting torque:** 20 in-lbs maximum

**Weight:** 16.95 g (approximately)

MAXIMUM RATINGS AND ELECTRICAL CHARACTERISTICS (T <sub>A</sub> =25°C unless otherwise noted)									
PARAMETER	SYMBOL	-005	-01	-02	-04	-06	-08	-10	UNIT
Maximum repetitive peak reverse voltage	V <sub>RRM</sub>	50	100	200	400	600	800	1000	V
Maximum RMS voltage	V <sub>RMS</sub>	35	70	140	280	420	560	700	V
Maximum DC blocking voltage	V <sub>DC</sub>	50	100	200	400	600	800	1000	V
Maximum average forward rectified current GBPC15 GBPC25 GBPC35	I <sub>F(AV)</sub>				15 25 35				A
Peak forward surge current, 8.3 ms single half sine-wave superimposed on rated load (JEDEC method)	I <sub>FSM</sub>				300 300 400				A
Maximum instantaneous forward voltage drop per element at specified current (Note 1)	V <sub>F</sub>	GBPC15 7.5A GBPC25 12.5A GBPC35 17.5A			1.1				V
Maximum reverse current @ Rated VR @ T <sub>J</sub> =25°C	I <sub>R</sub>				5				μA
Typical thermal resistance	R <sub>θJC</sub>				1.5				°C/W
Operating junction temperature range	T <sub>J</sub>				- 55 to +150				°C
Storage temperature range	T <sub>STG</sub>				- 55 to +150				°C

Note 1: Pulse test with PW=300μs, 1% duty cycle

Note 2: Suffix "W" - Wire Lead Structure / "M" - Terminal Location Face to Face

**ORDERING INFORMATION**

PART NO.	PACKING CODE	PACKAGE	PACKING
GBPC*5-xx (Note 1)	T0	GBPC	Tray

Note 1: "\*" defines current from 15A (GBPC15-xx) to 35A (GBPC35-xx),  
"xx" defines voltage from 50V (GBPC\*5-005) to 1000V (GBPC\*5-10)

**EXAMPLE**

PREFERRED P/N	PART NO.	PACKING CODE	DESCRIPTION
GBPC15-10 T0	GBPC15-10	T0	

**RATINGS AND CHARACTERISTICS CURVES**

(TA=25°C unless otherwise noted)

FIG. 1 FORWARD CURRENT DERATING CURVE

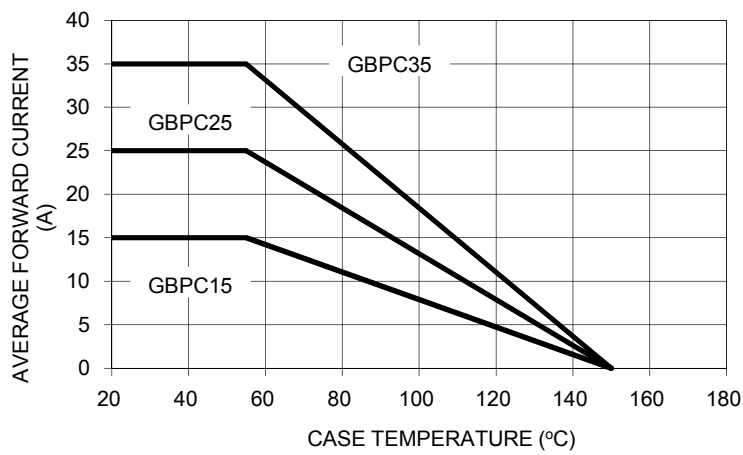

FIG. 2 TYPICAL REVERSE CHARACTERISTICS

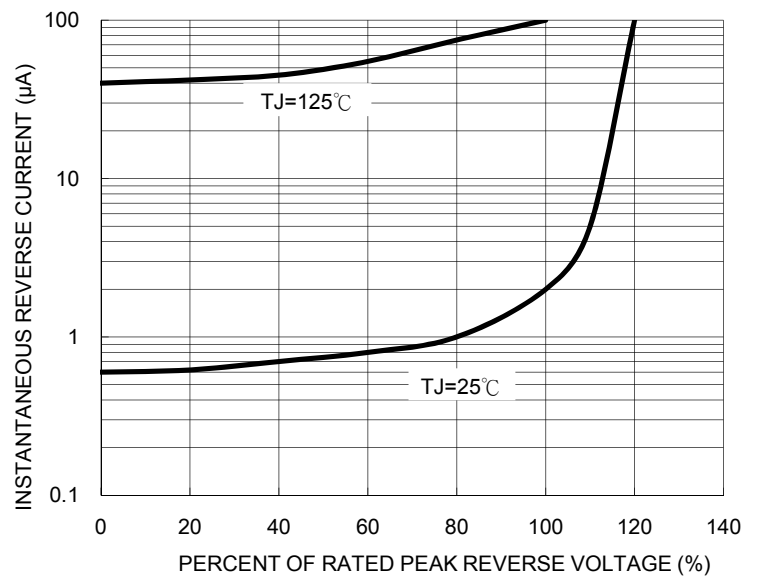

FIG. 3 MAXIMUM NON-REPETITIVE FORWARD SURGE CURRENT

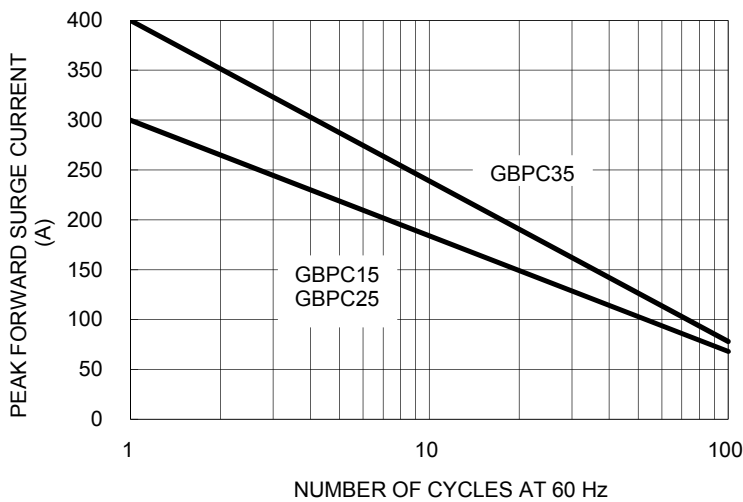

FIG. 4 TYPICAL FORWARD CHARACTERISTICS

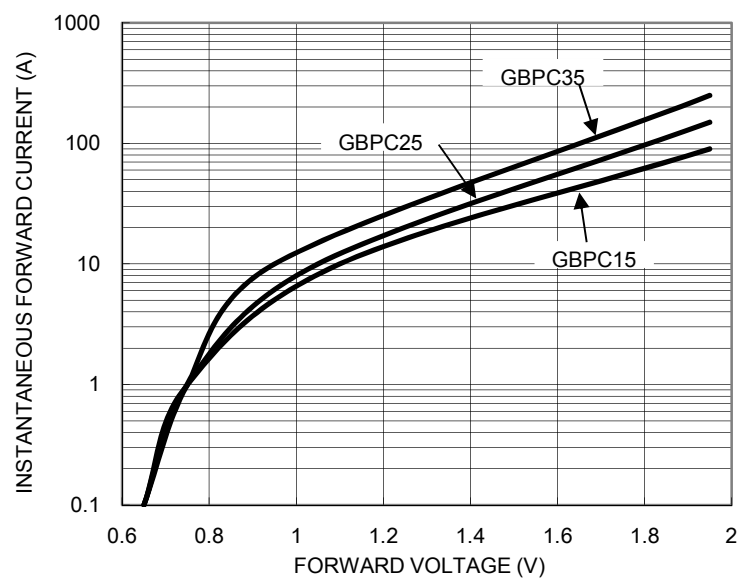
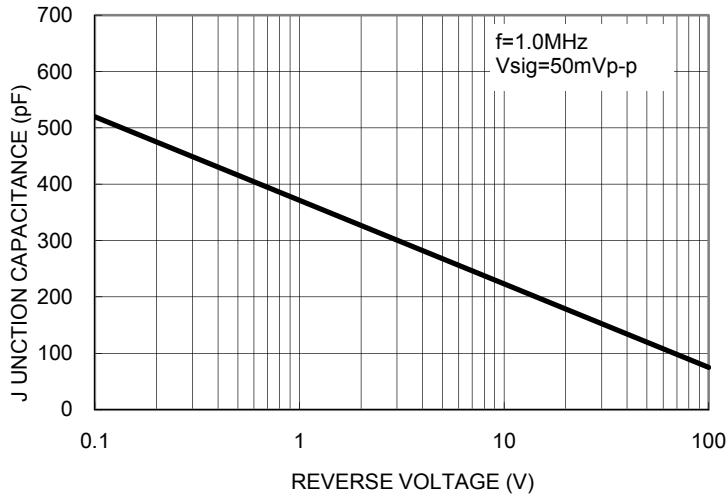
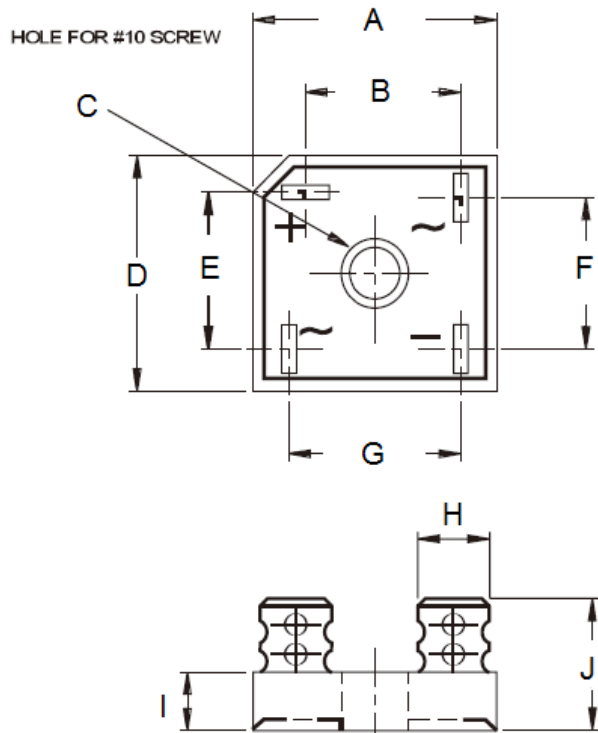

FIG. 5 TYPICAL JUNCTION CAPACITANCE



PACKAGE OUTLINE DIMENSIONS



GBPC				
DIM.	Unit (mm)		Unit (inch)	
	Min	Max	Min	Max
A	28.50	29.00	1.122	1.142
B	15.50	17.60	0.610	0.693
C	5.08	5.59	0.200	0.220
D	28.50	29.00	1.122	1.142
E	15.50	17.60	0.610	0.693
F	13.30	15.30	0.524	0.602
G	17.10	19.10	0.673	0.752
H	6.35 (TYP)		0.25 (TYP)	
I	10.97	11.23	0.432	0.442
J	21.50	24.50	0.846	0.965

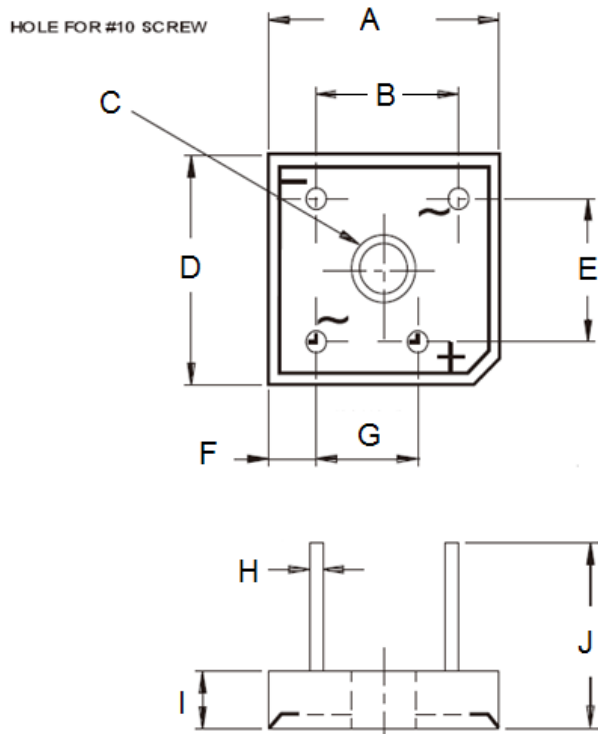

GBPC-W				
DIM.	Unit (mm)		Unit (inch)	
	Min	Max	Min	Max
A	28.50	29.00	1.122	1.142
B	17.10	19.10	0.673	0.752
C	5.08	5.59	0.200	0.220
D	28.50	29.00	1.122	1.142
E	17.10	19.10	0.673	0.752
F	4.40	6.20	0.173	0.244
G	10.40	12.40	0.409	0.488
H	0.97	1.07	0.038	0.042
I	10.97	11.23	0.432	0.442
J	30.50	-	1.201	-

PACKAGE OUTLINE DIMENSIONS



GBPC-M				
DIM.	Unit (mm)		Unit (inch)	
	Min	Max	Min	Max
A	28.50	29.00	1.122	1.142
B	15.50	17.60	0.610	0.693
C	5.08	5.59	0.200	0.220
D	28.50	29.00	1.122	1.142
E	15.50	17.60	0.610	0.693
F	15.50	17.60	0.610	0.693
G	15.50	17.60	0.610	0.693
H	0.76	0.86	0.030	0.034
I	6.6 (TYP)		0.26 (TYP)	
J	10.97	11.23	0.432	0.442
K	21.26	24.57	0.837	0.967

MARKING DIAGRAM

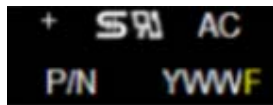

P/N = Specific Device Code  
YWW = Date Code  
F = Factory Code

## Notice

Specifications of the products displayed herein are subject to change without notice. TSC or anyone on its behalf, assumes no responsibility or liability for any errors inaccuracies.

Information contained herein is intended to provide a product description only. No license, express or implied, to any intellectual property rights is granted by this document. Except as provided in TSC's terms and conditions of sale for such products, TSC assumes no liability whatsoever, and disclaims any express or implied warranty, relating to sale and/or use of TSC products including liability or warranties relating to fitness for a particular purpose, merchantability, or infringement of any patent, copyright, or other intellectual property right.

The products shown herein are not designed for use in medical, life-saving, or life-sustaining applications. Customers using or selling these products for use in such applications do so at their own risk and agree to fully indemnify TSC for any damages resulting from such improper use or sale.