

Introduction

The ISL6269AEVAL2Z evaluation board demonstrates the performance of the ISL6269A or ISL6269B single-phase synchronous-buck PWM controller featuring Intersil's Robust Ripple Regulator (R³) technology. The ISL6269AEVAL2Z is shipped with the ISL6269A controller installed. The ISL6269B controller can be evaluated using the ISL6269AEVAL2Z with no further circuit modifications beyond changing the IC. An on-board dynamic-load generator is included for evaluating the transient-load response, that applies a 2.5ms pulse of 250mΩ across V_{OUT} and GND every 30ms. Contents of this document include:

- Design Criteria
- Recommended Test Equipment
- Interface Connections
- Switch Descriptions
- Jumper Descriptions
- Test Point Descriptions
- Typical Waveforms
 - Start-up
 - Shut-down
 - Diode-emulation
 - Load-transient response
 - Line-transient response
- Evaluation Board Documentation
 - Schematic
 - Bill of materials
 - Silk-screen plots
 - Board layer plots

TABLE 1. DC/DC DESIGN CRITERIA

PARAMETER	VALUE	UNITS
VIN	5 to 25	VDC
VOUT	1.10 or 1.20	VDC
FULL-LOAD	5.0	ADC
PWM FREQUENCY	300 or 600	kHz

Design Criteria

The design criteria listed in Table 1 was, to a large extent, influenced by customer input. The PWM switching frequency can be programmed to any frequency between 200kHz and 600kHz. If only one PWM frequency setting is desired, this can be accomplished by simply not populating R₁₇. The output voltage can be programmed to any voltage between

0.6V and 3.3V. If only one output voltage setting is desired, this can be accomplished by simply not populating R₁₆.

The OCP setpoint resistor R_{SEN} (R₁₃) is selected to protect the output load, without nuisance shutdowns due to component tolerances and temperature effects. Using Equation 1 finds R_{SEN} (R₁₃) = 6.49kΩ where:

$$R_{SEN} = \frac{(I_{FL} + \frac{I_{PP}}{2}) \cdot OC_{SP} \cdot r_{DS(ON)}}{I_{OC}} \quad (EQ. 1)$$

- r_{DS(ON)} of Q4 low-side MOSFETs is 15mΩ
- I_{OC} is 26μA
- I_{FL} is 5A continuous
- I_{PP} is 1.5A_{PP} (30% of I_{FL} 5A)
- OC_{SP} is 2.1 (210% of I_{FL})

The PWM switching frequency f_{SW} is programmed for 300kHz by resistance R_{FSET} (R₁₂) when switch S2 is in the LOWER position. Setting switch S2 in the UPPER position will program f_{SW} for approximately 600kHz with the parallel resistance of R₁₂ and R₁₇. Using Equation 2 finds the value for R_{FSET} (R₁₂) = 57.6kΩ. The "K" constant in Equation 2 is ideally 66.8 x 10⁻¹² however, this value can be affected by the ripple voltage on the COMP pin. The ripple voltage on the COMP pin increases with the bandwidth of the feedback loop compensation, effectively reducing the value of "K". The ISL6269AEVAL2Z evaluation board is aggressively compensated for approximately 100kHz bandwidth, making the value of "K" effectively 58 x 10⁻¹².

$$R_{FSET} = \frac{1}{K \cdot f_{SW}} \quad (EQ. 2)$$

The output voltage is programmed for 1.10V using resistors R₁₉ (R_{TOP}) and R₂₀ (R_{BOTTOM}) when switch S3 is in the LOWER position. Setting switch S3 in the UPPER position will program the output voltage for 1.20V using resistor R₁₉ (R_{TOP}) and the parallel resistance of R₂₀ and R₁₆ (R_{BOTTOM}). The loop compensation is usually responsible for selecting R_{TOP} (R₁₉), which in this case is 3.01kΩ. The voltage setpoint programming resistance R_{BOTTOM} is calculated using Equation 3 where:

$$R_{BOTTOM} = \frac{(V_{REF} \cdot R_{TOP})}{(V_{OUT} - V_{REF})} \quad (EQ. 3)$$

- V_{REF} = 600mV
- R_{TOP} = 3.01kΩ
- V_{OUT} = 1.10V or 1.20V

Begin by finding the value of R₂₀ for V_{OUT} = 1.10V from Equation 2: R₂₀ = 3.57kΩ. Find the value of parallel resistance R₂₀ and R₁₆ for V_{OUT} = 1.20V from Equation 3: R₂₀ || R₁₆ = 3.01kΩ, therefore R₁₆ = 19.1kΩ.

Recommended Equipment

- (QTY 1) Adjustable 25V, 3A Power Supply
- (QTY 1) Fixed 12V, 100mA Power Supply
- (QTY 1) Fixed 5V, 100mA Power Supply
- (QTY 1) Adjustable 5A Constant Current Electronic Load
- (QTY 1) DVM
- (QTY 1) Four Channel Oscilloscope

Interface Connections

- V_{IN} : Input voltage to the power stage of the converter
 - J5: V_{IN} positive power input
 - J7: V_{IN} return power input
- V_{OUT} : Regulated output voltage from the converter
 - J6: V_{OUT} positive power output
 - J8: V_{OUT} return power output
- +5VIN: +5V input voltage for PVCC, PGOOD-LED, and pull-up voltage rail
 - J2: 5V positive input
 - J1: 5V return input
- +12V: Input voltage for the dynamic-load generator
 - J4: 12V positive input
 - J3: 12V return input

Switch Descriptions

- S1: ENABLE
 - OFF: Shorts the EN pin to GND (disable PWM)
 - ON: Allows the EN pin to pull-up to +5V (enable PWM)
- S2: DYNAMIC FPWM
 - LOWER: Selects the lower of two programmed f_{SW}
 - UPPER: Selects the higher of two programmed f_{SW}
- S3: DYNAMIC VOUT
 - LOWER: Selects the lower of two programmed output voltages
 - UPPER: Selects the higher of two programmed output voltages
- S4: FCCM
 - DEM: Enables diode-emulation-mode
 - CCM: Inhibits diode-emulation-mode
- S5: DYNAMIC LOAD
 - OFF: Load disabled
 - ON: Load enabled

Jumper Descriptions

- JP1: Selects the +5V source for VCC, PVCC and auxiliary circuits. See Table 1 for list of configurations.
- JP2: Connects +5V supply to the PGOOD LED circuit and pull-up resistors. The shunt jumper is normally installed. Remove the shunt jumper when making low power efficiency measurements.
- JP3: Isolates the EN input pin from switch S1 so that an external signal can be used.
- JP4: Isolates the frequency range selection switch S2 so that an external signal can be used.
- JP5: Isolates the V_{OUT} selection switch S3 so that an external signal can be used.
- JP6: Isolates the FCCM input pin from switch S4 so that an external signal can be used.
- JP7: Isolates the PGOOD input pin from the LED circuit so that the pull-down resistance can be measured.
- JP8: Opens the circuit path to the VIN pin so that an ammeter can be inserted for measuring current into the VIN pin.

TABLE 2. JUMPER JP1 CONFIGURATIONS

JP1			SOURCE OF 5V		
PIN 1 to 2	PIN 3 to 4	PIN 5 to 6	VCC	PVCC	AUX
SHORT	SHORT	SHORT	J2	J2	J2
SHORT	OPEN	SHORT	TP8	TP8	J2
SHORT	SHORT	OPEN	J2	TP7	J2

Test-point Descriptions

- TP1 to TP5: Signal ground
- TP6: Scope-probe socket for measuring V_{IN}
- TP7: Monitors the voltage at the PVCC pin
- TP8: Monitors the voltage of JP1 pins 2, 4 and 6
- TP9: Monitors the voltage at JP4 pin 1
- TP10: Monitors the voltage at JP5 pin 1
- TP11: Monitors the voltage at the PGOOD pin
- TP12: Monitors the voltage at the FSET pin
- TP13: Monitors the voltage at the upper feedback resistor
- TP14: Monitors the voltage at the FB pin (SENSITIVE)
- TP15: Monitors the voltage at the COMP pin (SENSITIVE)
- TP16: Monitors the voltage at the EN pin
- TP17: Monitors the voltage at the FCCM pin
- TP18: Monitors the voltage at the VCC pin
- TP19: Scope-probe socket for measuring V_{OUT}
- TP20: V_{IN} positive voltage sense
- TP21: V_{IN} return voltage sense
- TP22: Monitors the voltage at the VIN pin
- TP23: V_{OUT} positive voltage sense
- TP24: V_{OUT} return voltage sense
- TP25: Scope-probe socket for measuring the voltage of the PHASE node
- TP26: Scope-probe socket for measuring voltage across the dynamic-load resistors (hence load current)
- TP27: Monitors the voltage at the gate terminal of the dynamic load MOSFET

Typical Waveforms

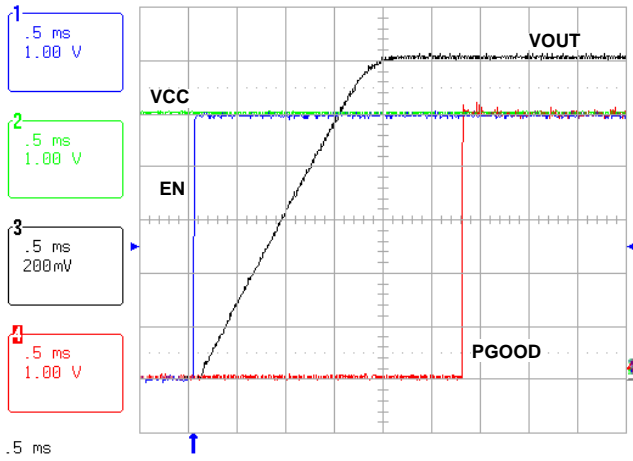

FIGURE 1. SOFT-START: 250mΩ LOAD, FCCM = HIGH

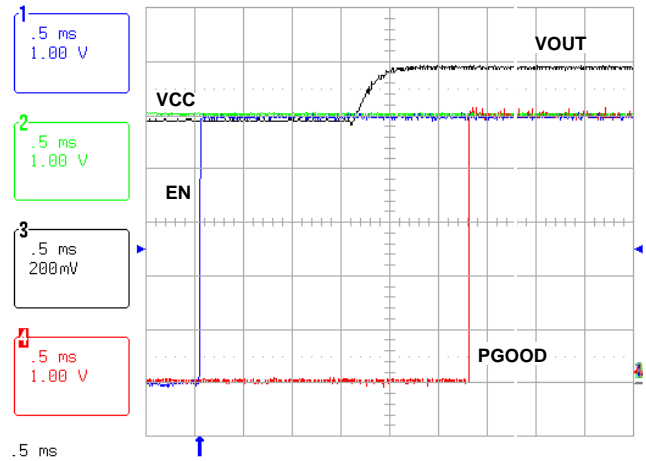

FIGURE 2. SOFT-START: NO-LOAD, FCCM = HIGH, 1V VOUT-PREBIAS

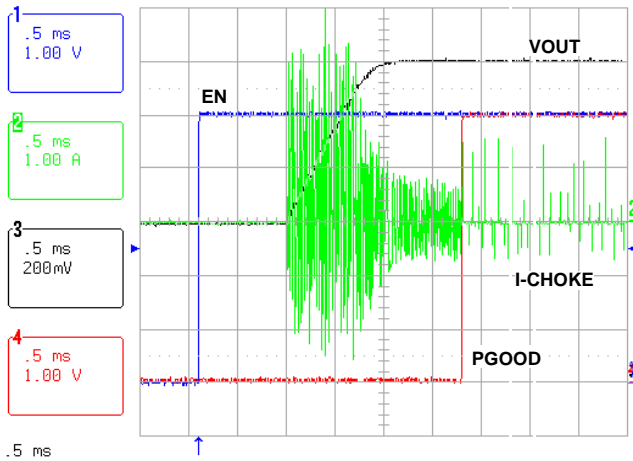

FIGURE 3. OUTPUT CAPACITOR IN-RUSH CURRENT: 50Ω LOAD, FCCM = LOW, 1V VOUT-PREBIAS

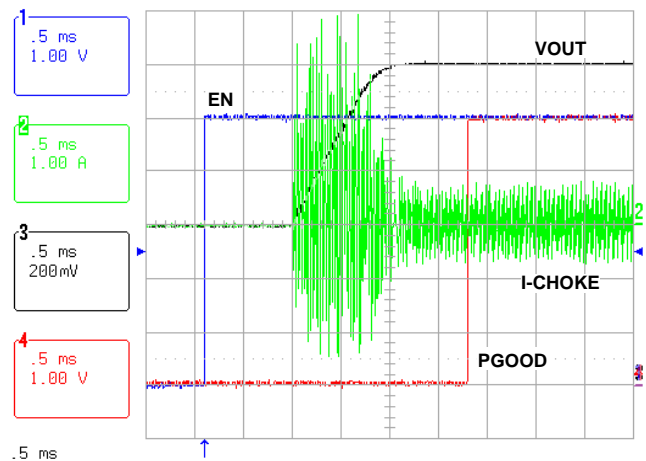

FIGURE 4. OUTPUT CAPACITOR IN-RUSH CURRENT: 50Ω LOAD, FCCM = HIGH, 1V VOUT-PREBIAS

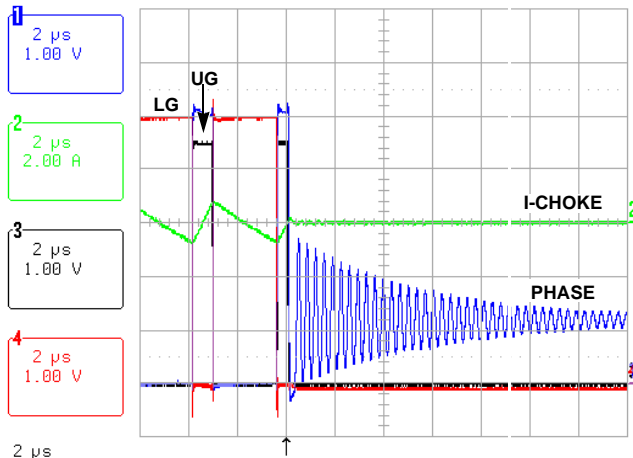

FIGURE 5. SHUTDOWN: EN PULLED LOW, NO-LOAD

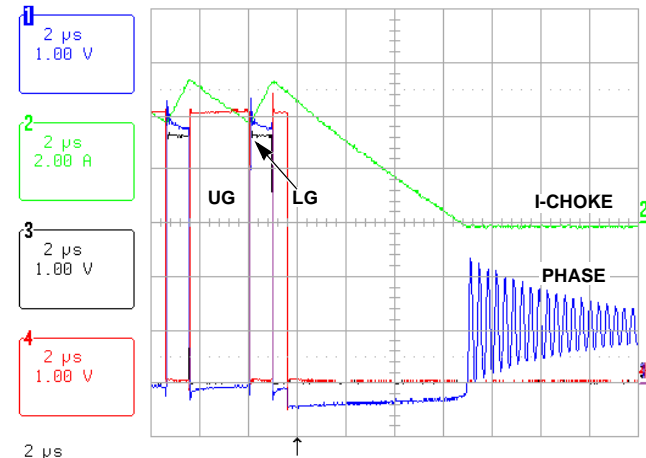

FIGURE 6. SHUTDOWN: EN FALLING, 250mΩ-LOAD

Typical Waveforms (Continued)

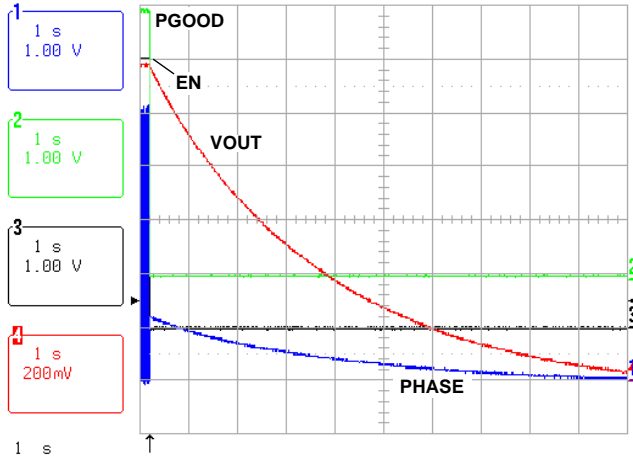

FIGURE 7. SHUTDOWN: VOUT DECAY, NO-LOAD

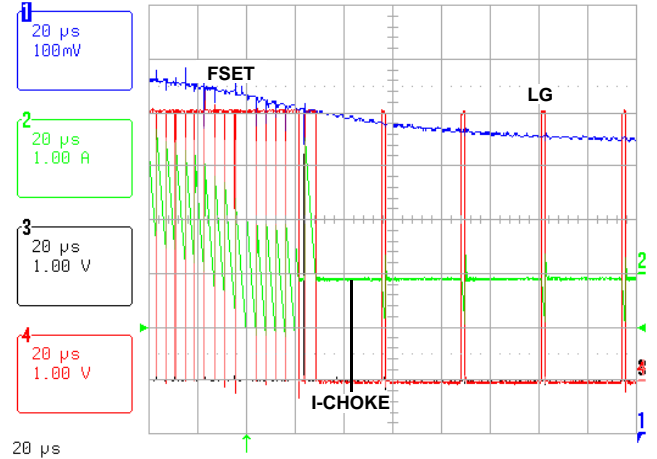

FIGURE 8. ENTERING DEM: 250mΩ LOAD-DUMP (UG TOO NARROW TO SEE)

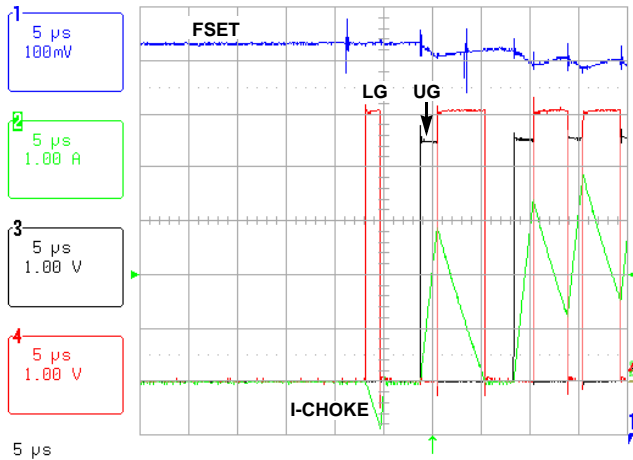

FIGURE 9. EXITING DEM: 250mΩ LOAD-STEP

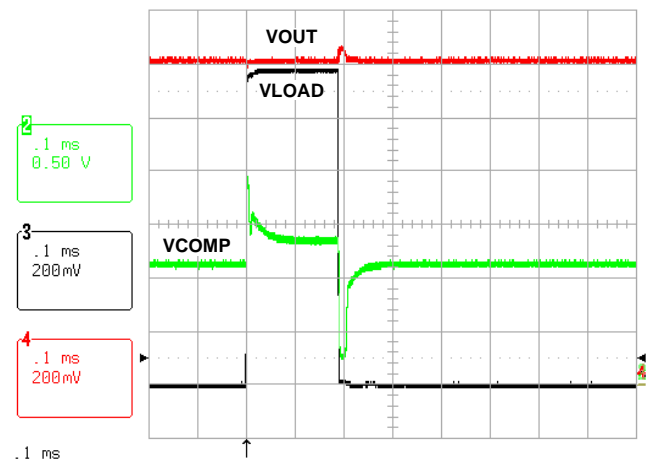

FIGURE 10. LOAD TRANSIENT: FCCM = HIGH, IN CCM BEFORE 250mΩ LOAD-STEP

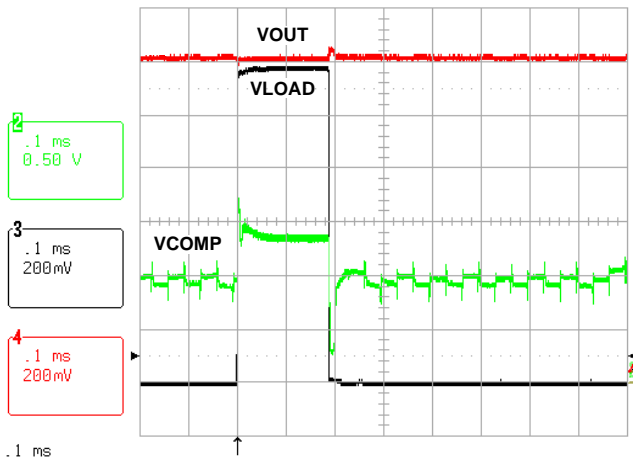

FIGURE 11. LOAD TRANSIENT: FCCM = LOW, IN DEM BEFORE 250mΩ LOAD-STEP

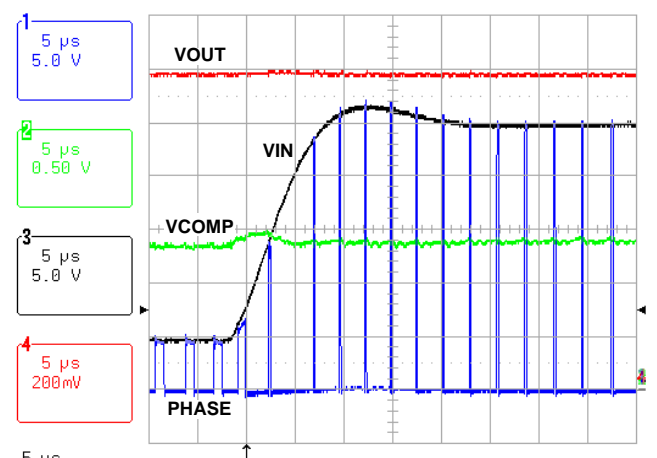

FIGURE 12. LINE TRANSIENT: 5V TO 25V STEP, 250mΩ LOAD

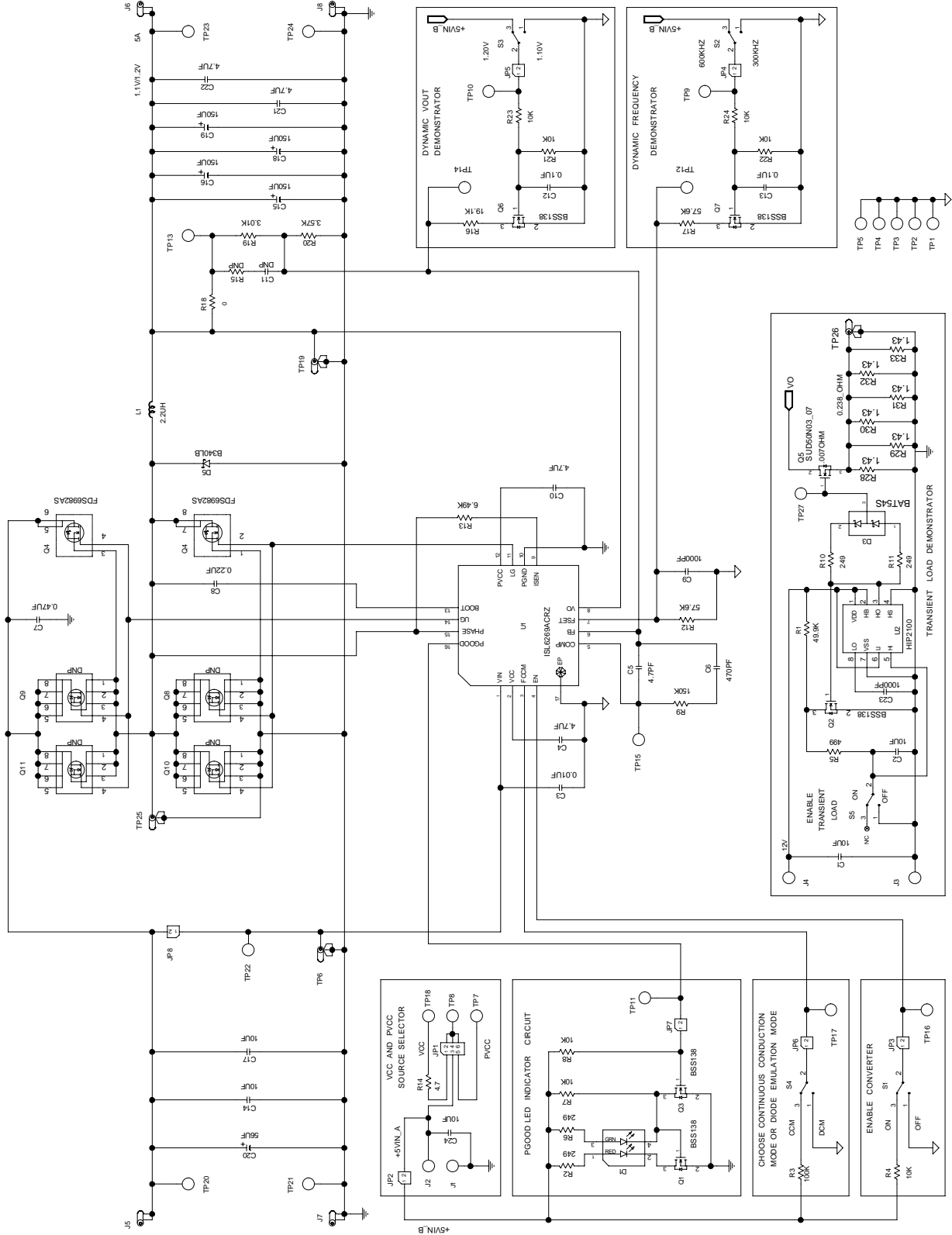

FIGURE 13. ISL6269AEVAL2Z REV C CIRCUIT SCHEMATIC

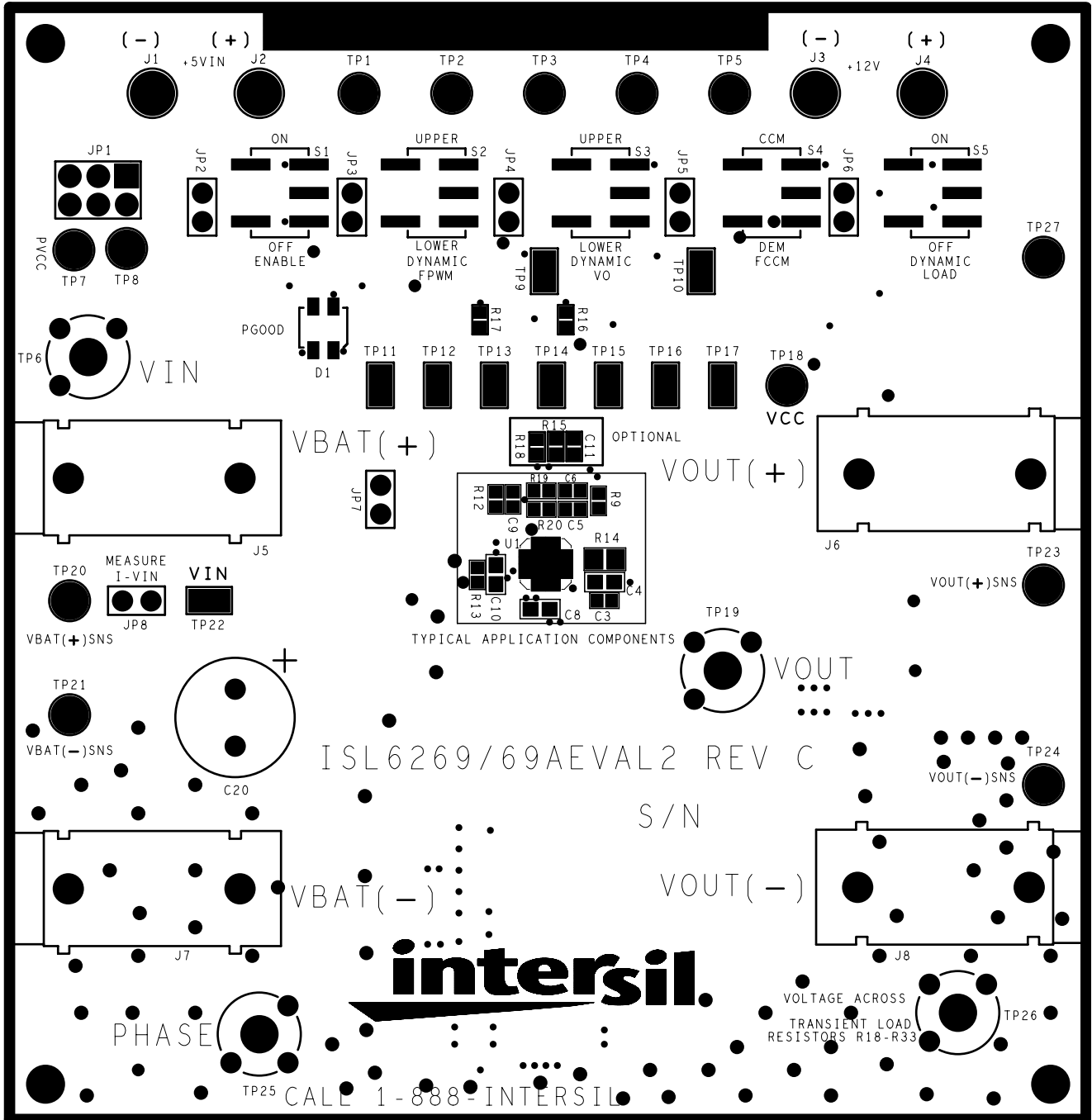

FIGURE 14. PCB TOP SILK SCREEN

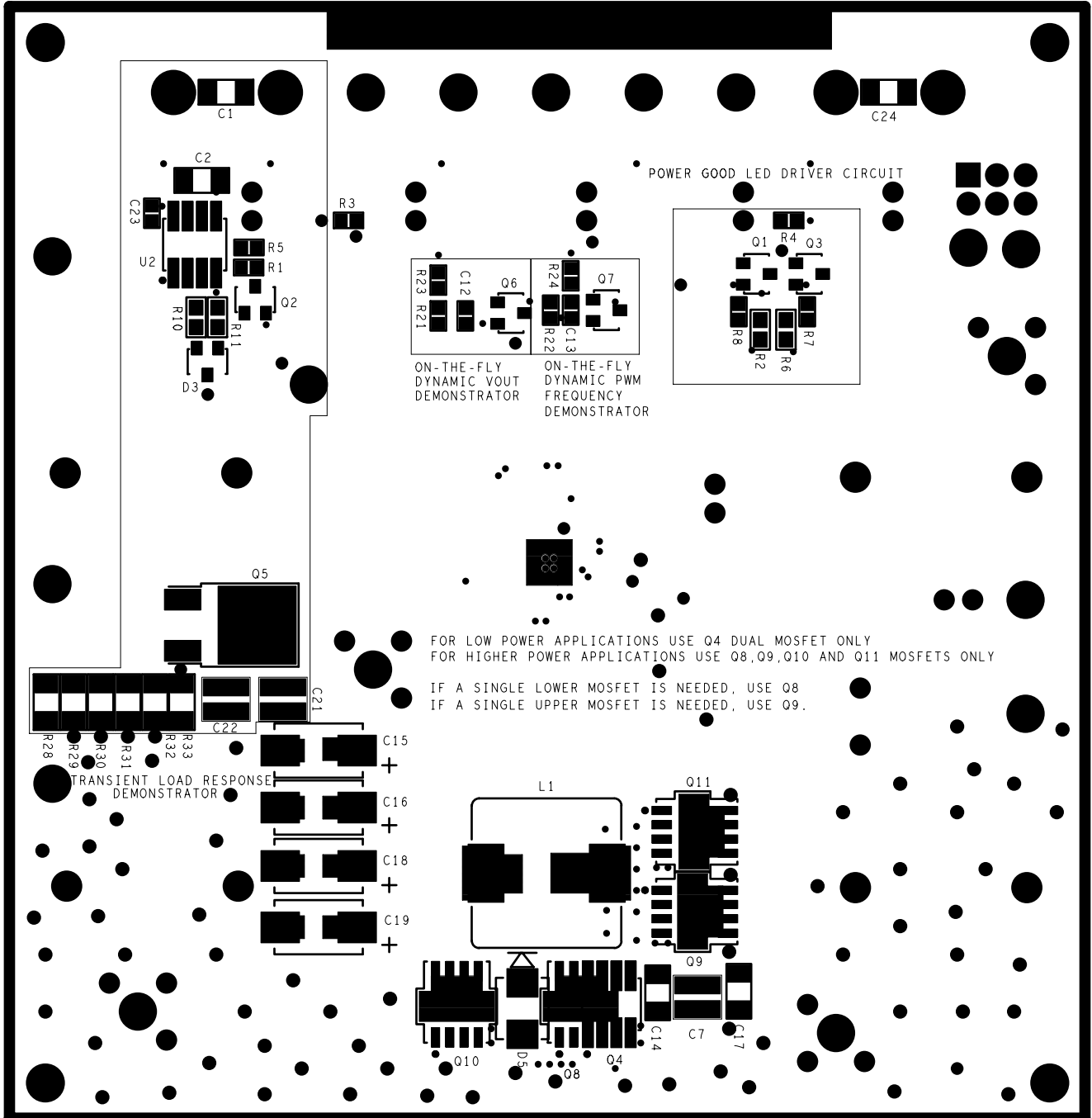

FIGURE 15. PCB BOTTOM SILK SCREEN (MIRRORED)

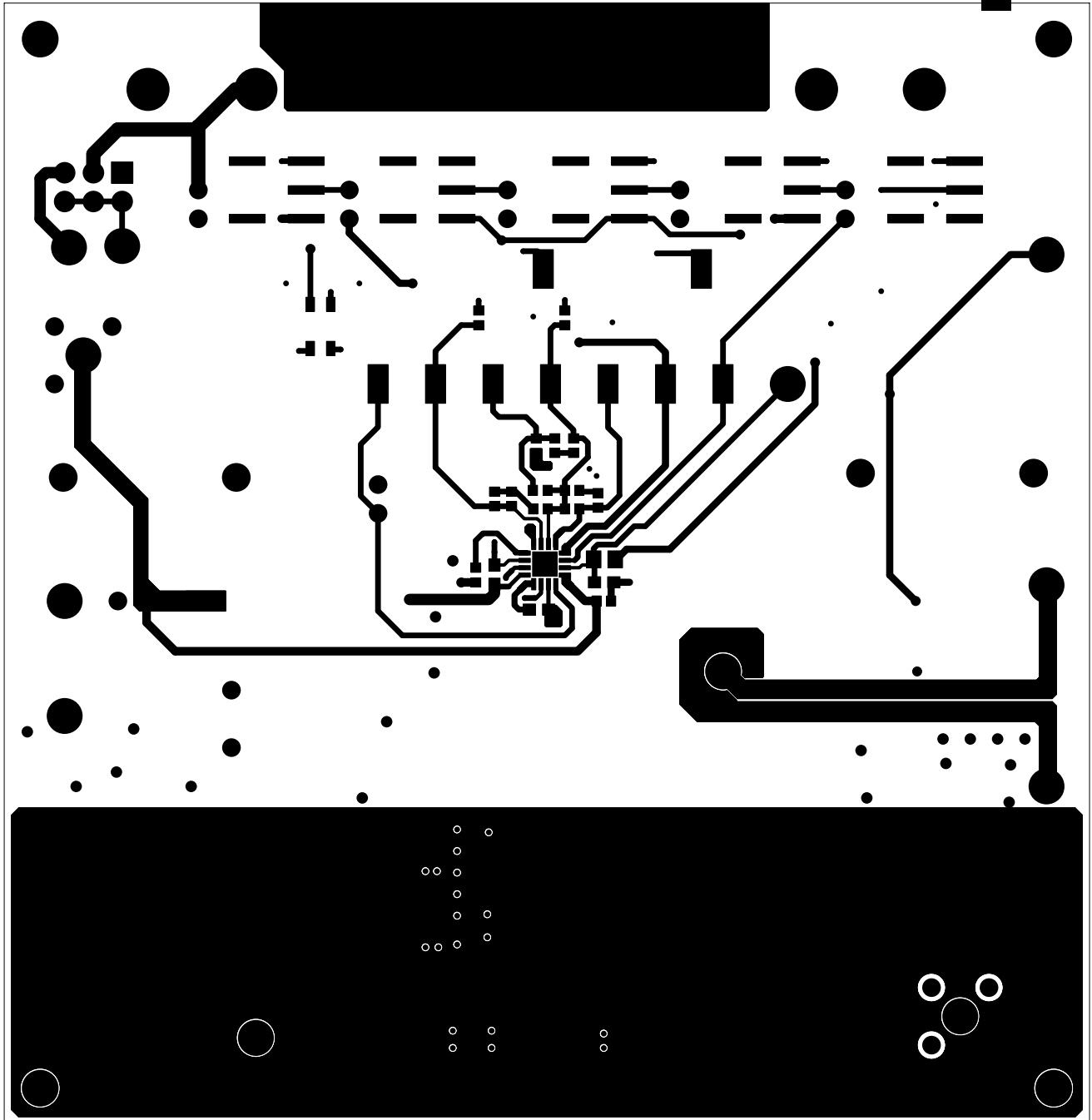

FIGURE 16. PCB TOP LAYER ETCH

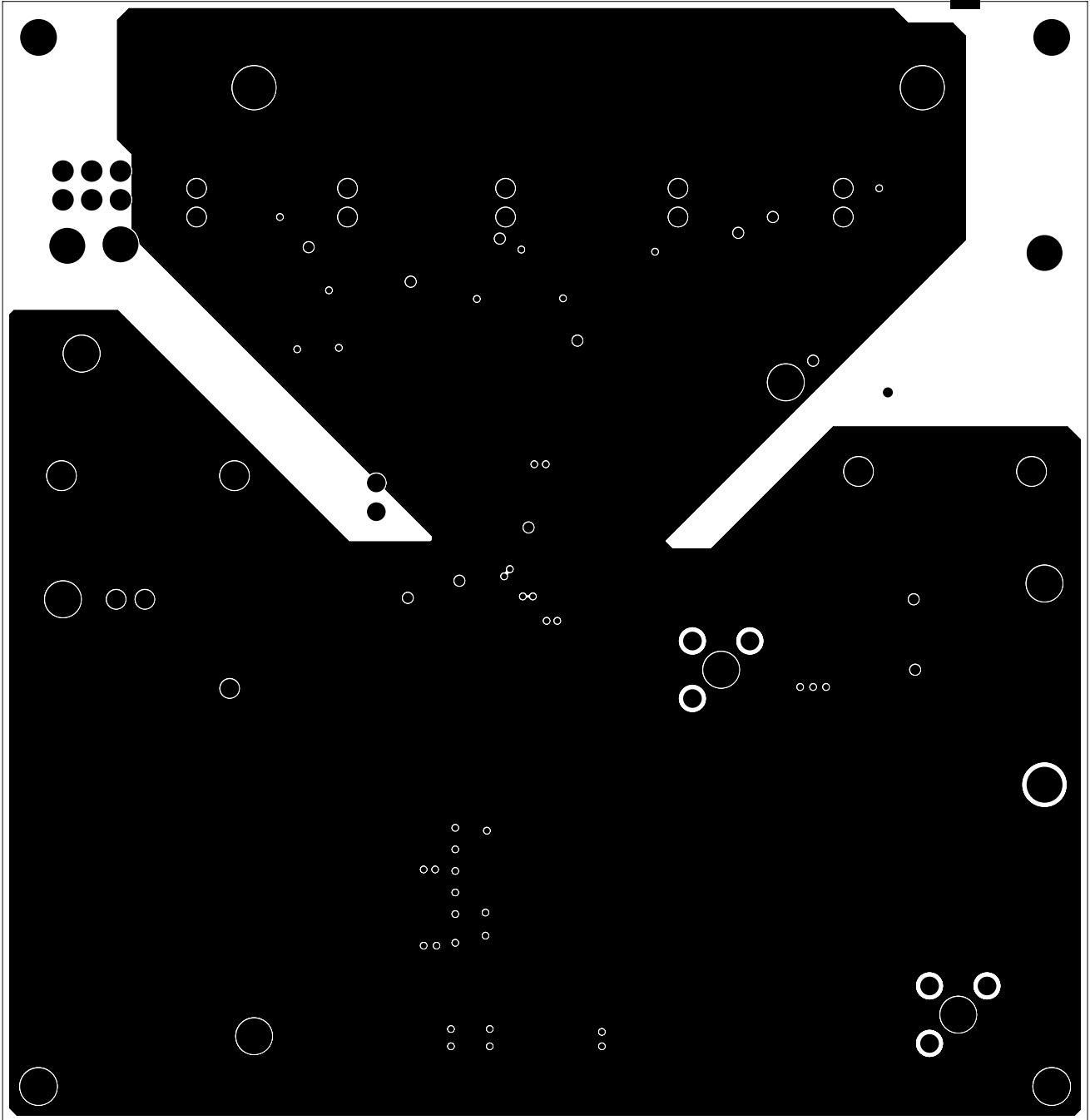

FIGURE 17. PCB LAYER 2 ETCH

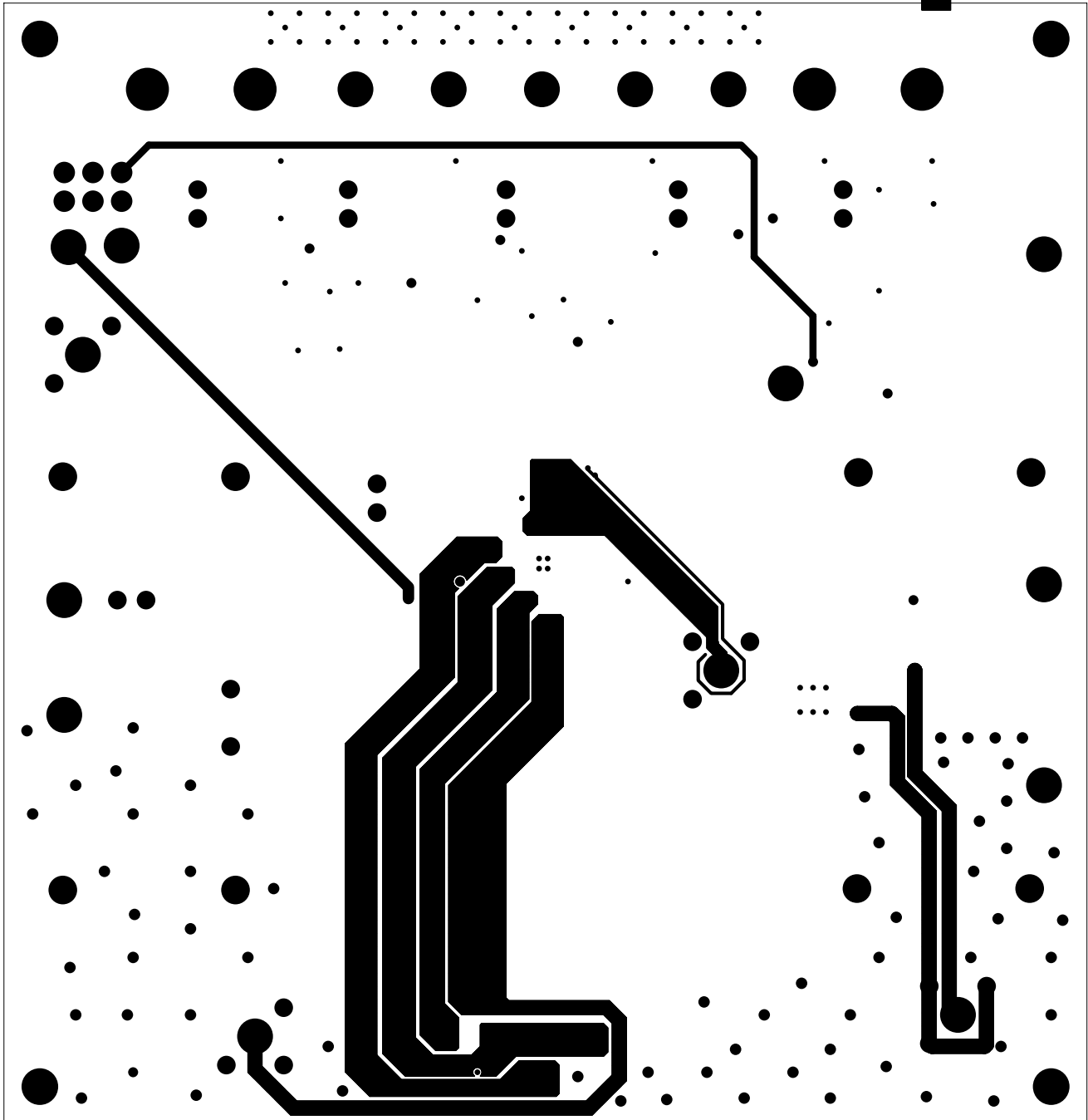

FIGURE 18. PCB LAYER 3 ETCH

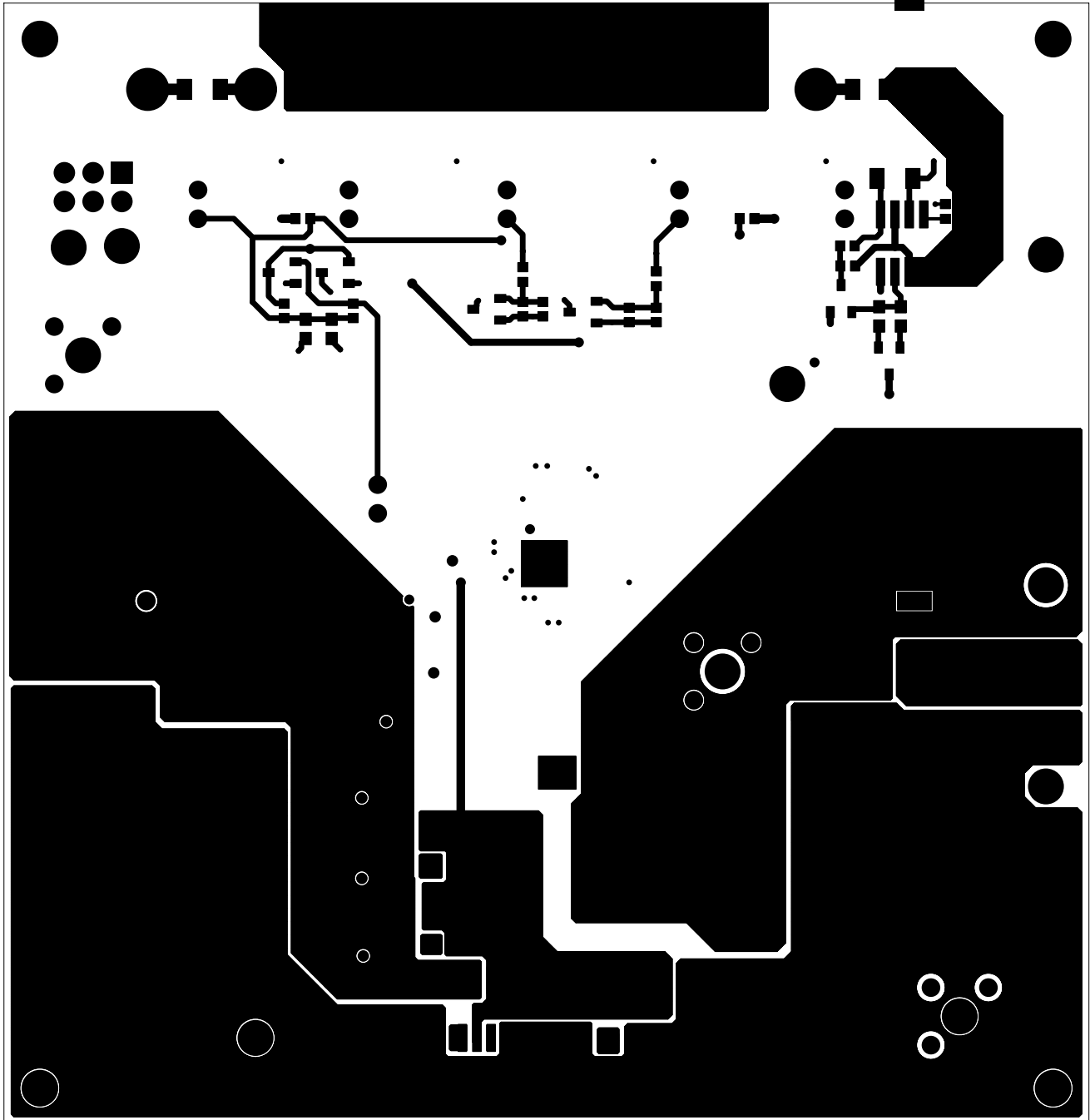

FIGURE 19. PCB BOTTOM LAYER ETCH

Application Note 1273

Bill of Materials

QTY	REFERENCE	DESCRIPTION/COMMENT	MFG NAME	MFG NUMBER
5	C1, C2, C14, C17, C24	CAP, SMD, 1206, 10 μ F, 25V, 20%, X5R, ROHS	PANASONIC	ECJ-3YB1E106M
2	C12, C13	CAP, SMD, 0402, 0.1 μ F, 16V, 10%, X7R, ROHS	MURATA	GRM36X7R104K016AD
4	C15, C16, C18, C19	CAP, SMD, 7.3mmx4.3mm, 150 μ F, 4V, 20%, SP-CAP	PANASONIC	EEF-SD0G151R
1	C20	CAP, RADIAL, 56 μ F, 25V, OSCON	SANYO	25SP56M
2	C21, C22	CAPACITOR, SMD, 0612, 4.7 μ F, 6.3V, 10%, X5R	TDK	C1632X5R0J475K
1	C3	CAP, SMD, 0402, 0.01 μ F, 25V, 10%, X7R, ROHS	AVX	04023C103KAT
2	C4, C10	CAP, SMD, 0603, 4.7 μ F, 6.3V, 20%, X5R, ROHS	TDK	C1608X5R0J475M
1	C5	CAP, SMD, 0402, 4.7pF, 50V, 0.25pF, NPO, ROHS	MURATA	GRM36COG4R7C050AQ
1	C6	CAP, SMD, 0402, 470pF, 50V, 10%, X7R, ROHS	PANASONIC	ECJ-0EB1H471K
1	C7	CAPACITOR, SMD, 0612, 0.47 μ F, 25V, 10%, X7R	TDK	C1632X7R1E474K
1	C8	CAP, SMD, 0603, 0.22 μ F, 25V, 20%, X7R, ROHS	VISHAY	VJ0603X224MXXAT
2	C9, C23	CAP, SMD, 0402, 1000pF, 50V, 5%, C0G, ROHS	MURATA	GRM1555C1H102JA01D
1	D1	LED, SMD, 3mmx2.5mm, 4P, RED/GREEN, 12/20MCD, 2V	LUMEX	SSL-LXA3025IGC-TR
1	D3	DIODE, SCHOTTKY, DUAL, SOT23, 30V, 200mA	FAIRCHILD	BAT54S
1	D5	DIODE-SCHOTTKY, SMB, 40V, 3A, LOW-VF, ROHS	DIODES INC.	B340LB-13-F
4	J1 to J4	TERMINAL, TURRET-POST, TH, ROHS	KEYSTONE	1514-2
2	J5, J6	PLUG, BANANA, THRU-HOLE, RED, 4.23mm, ROHS	MOUSER	164-6219
2	J7, J8	PLUG, BANANA, THRU-HOLE, BLKD, 4.23mm, ROHS	MOUSER	164-6218
1	JP1	HEADER, 2x3, BRKAWY 2x36, 2.54mm, ST	BERG/FCI	67996-272
7	JP2 to JP8	HEADER, 1x2, RETENTIVE, 2.54mm, ST, ROHS	BERG/FCI	69190-202
10	JP1(1 to 2, 3 to 4, 5 to 6), JP2 to JP8	JUMPER, 2 PIN, HIGHBDY, SHUNT	BERG/FCI	71363-102
1	L1	INDUCTOR, SMD, 13mm, 2.2 μ H, 20%, 29A, SHIELDED	VISHAY	IHLP5050CEER2R2M01
5	Q1, Q2, Q3, Q6, Q7	MOSFET, N-CH, SMD, 3P, SOT23, 50V, 0.2A, Pb-free	DIODES INC.	BSS138-7-F
1	Q4	MOSFET, N-CH, DUAL, 8P, SOIC, 30V, 17m Ω	FAIRCHILD	FDS6982AS
1	Q5	MOSFET, N-CH, SMD, TO-252AA, 30V, 7m Ω	VISHAY	SUD50N03-07
1	R1	RES, SMD, 0402, 49.9k, 1/16W, 1%, TF, ROHS	PANASONIC	ERJ-2RKF4992
2	R12, R17	RES, SMD, 0402, 57.6k, 1/16W, 1%, TF, ROHS	PANASONIC	ERJ-2RKF5762X
1	R13	RES, SMD, 0402, 6.49k, 1/16W, 1%, TF, ROHS	YAGEO	RC0402FR-076K49L
1	R14	RES, SMD, 0805, 4.7 Ω , 1/8W, 5%, TF, ROHS	PANASONIC	ERJ-6GEYJ4R7V
1	R16	RES, SMD, 0402, 19.1k, 1/16W, 1%, TF, ROHS	PANASONIC	ERJ-2RKF1912
1	R18	RES, SMD, 0402, 0 Ω , 1/16W, 5%, TF, ROHS	PANASONIC	ERJ-2GE0JR00
1	R19	RES, SMD, 0402, 3.01k, 1/16W, 1%, TF, ROHS	PANASONIC	ERJ-2RKF3011
4	R2, R6, R10, R11	RES, SMD, 0603, 249 Ω , 1/16W, 1%, TF, ROHS	PANASONIC	ERJ-3EKF2490
1	R20	RES, SMD, 0402, 3.57k, 1/16W, 1%, TF, ROHS	PANASONIC	ERJ-2RKF3571X
6	R28 to R33	RES, SMD, 1206, 1.43 Ω , 1/4W, 1%, TF, ROHS	YAGEO	RC1206FR-071R43L
1	R3	RES, SMD, 0402, 100k, 1/16W, 1%, TF, ROHS	PANASONIC	ERJ2RKF1003
7	R4, R7, R8, R21 to R24	RES, SMD, 0402, 10k, 1/16W, 1%, TF, ROHS	PANASONIC	ERJ-2RKF1002
1	R5	RES, SMD, 0402, 499 Ω , 1/16W, 1%, TF, ROHS	PANASONIC	ERJ-2RKF4990X
1	R9	RES, SMD, 0402, 150k, 1/16W, 1%, TF, ROHS	YAGEO	RC0402FR-07150KL

Application Note 1273

Bill of Materials (Continued)

QTY	REFERENCE	DESCRIPTION/COMMENT	MFG NAME	MFG NUMBER
5	S1 to S5	SWITCH-TOGGLE, SMD, ULTRAMINI, 1P, SPST, MINI	C&K COMPONENTS	GT11MSCKE
7	TP1 to TP5, TP21, TP24	COMPACT TEST PT, VERTICAL, BLK, ROHS	KEYSTONE	5006
1	TP27	COMPACT TEST PT, VERTICAL, WHT, ROHS	KEYSTONE	5007
4	TP6, TP19, TP25, TP26	SCOPE PROBE TEST POINT, PCB MNT	TEKTRONIX	131-4353-00
5	TP7, TP8, TP18, TP20, TP23	COMPACT TEST PT, VERTICAL, RED, ROHS	KEYSTONE	5005
10	TP9 to TP17, TP22	MINI TEST POINT, SMD	KEYSTONE	5015
1	U1	IC-GPU CONTROLLER, 16P, QFN, 4x4, Pb-free	INTERSIL	ISL6269ACRZ
1	U2	IC-HI FREQ BRIDGE DRIVER, 8P, SOIC, 100V	INTERSIL	HIP2100IB

Intersil Corporation reserves the right to make changes in circuit design, software and/or specifications at any time without notice. Accordingly, the reader is cautioned to verify that the Application Note or Technical Brief is current before proceeding.

For information regarding Intersil Corporation and its products, see www.intersil.com