

Datasheet.Directory

NO. OF CONTACTS	A	B	C
9	.500	.395	.200
15	.650	.545	.350
21	.800	.695	.500
25	.900	.795	.600
31	1.050	.945	.750
37	1.200	1.095	.900
51	1.550	1.445	1.250

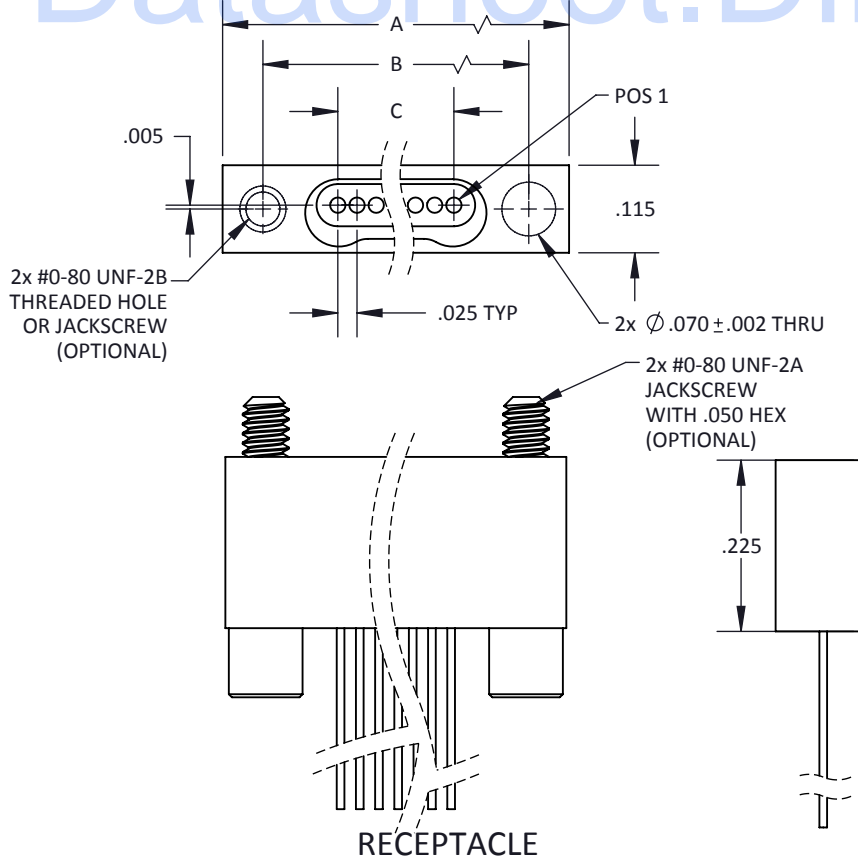

TOLERANCE: .XXX \pm .005
.XX \pm .01
ANGLE \pm 1°

TITLE NANO METAL SHELL
SINGLE ROW
WITH LEADS

SHT 1 OF 2

DWG. NO. CMN1

REV D



NANO METAL SHELL SINGLE ROW WITH LEADS

CMN 1 - XX X - X X X X X X X

NANO METAL SHELL WITH LEADS

BODY STYLE
1 = SINGLE ROW

NUMBER OF CONTACTS
09 25 51
15 31
21 37

GENDER
P = PLUG, PIN CONTACTS
S = RECEPTACLE, SOCKET CONTACTS

HARDWARE
0 = NONE (THRU HOLE ONLY)
J = JACKSCREW (CAPTURED)
T = #0-80 THREADED HOLE

SHELL FINISH
ALUMINUM
A = CADMIUM
B = NICKEL
C = ZINC-NICKEL
G = GOLD
STAINLESS STEEL
P = PASSIVATE
TITANIUM
T = TITANIUM (FINISH N/A)

WIRE LENGTH
STRANDED (+1.00 / -0.00)
1 = 6 INCHES
2 = 12 INCHES
3 = 18 INCHES
4 = 24 INCHES
5 = 36 INCHES
6 = 72 INCHES
SOLID COPPER (+0.20 / -0.00)
30 AWG
1 = 0.5 INCH
2 = 1.0 INCH
3 = 0.25 INCH

WIRE SIZE
0 = 32 AWG STRANDED/30 AWG SOLID
1 = 30 AWG STRANDED

WIRE COLOR/TYPE
0 = WHITE *
1 = YELLOW
2 = 10 SOLID COLORS REPEATED *
3 = FULL COLOR CODE
9 = SOLID COPPER *

TERMINATION
WIRE TYPE
STRANDED
H = HARNESS (MIL-W-16878/6)
S = SPACE M22759/33
M = 04047-30A
N = NEMA HP3
SOLID
G = GOLD PLATED COPPER
T = TIN/LEAD PLATED COPPER

* = MOST COMMONLY USED & STOCKED WIRE TYPES AND HARDWARE OPTIONS

MATERIALS AND FINISHES ARE IAW MIL-DTL-32139 WHERE APPLICABLE.
FOR DETAILS SEE MIL-SPEC OR WWW.CRISTEK.COM

1. MATERIALS:

SHELL - ALUMINUM ALLOY, STAINLESS STEEL OR TITANIUM
INSULATOR - LIQUID CRYSTAL POLYMER OR GLASS FILLED THERMOPLASTIC
CONTACT - COPPER ALLOY

2. FINISH:

SHELL - ELECTROLESS NICKEL OR CADMIUM OVER ELECTROLESS NICKEL OR PASSIVATE OR GOLD OR ZINC NICKEL
CONTACT - GOLD OVER NICKEL

3. SPECIFICATIONS:

CURRENT RATING ----- 1 AMP MAX
TEMPERATURE RATING ----- -55° C TO +125° C
INSULATION RESISTANCE ----- 5000 MEGOHMS
DWV AT SEA LEVEL ----- 250 VAC
DWV AT 70,000 FT ALTITUDE --- 100 VAC
CONTACT RESISTANCE ----- 30 mV DROP @ 1 A, 10 mA
CONTACT RETENTION ----- 2 LBS AXIAL LOAD
ENGAGEMENT FORCE ----- 5 oz MAX
SEPARATION FORCE ----- 0.4 oz MIN

4. ADDITIONAL INFORMATION:

FOR OTHER TERMINATIONS, CONTACT CRISTEK.

TOLERANCE: .XXX ±.005 .XX ±.01 ANGLE ±1°	TITLE NANO METAL SHELL SINGLE ROW WITH LEADS	SHT 2 OF 2	DWG. NO. CMN1	REV D
--	--	------------	-------------------------	-----------------