

Customer Information Sheet

DRAWING No.: S409-XXBX, S410-XXBX SHEET 3 OF 3 IF IN DOUBT - ASK (C) NOT TO SCALE THIRD ANGLE PROJECTION ALL DIMENSIONS IN mm



SEE NOTE 1

COMPONENTS SHOWN COILED
READY FOR INSERTION

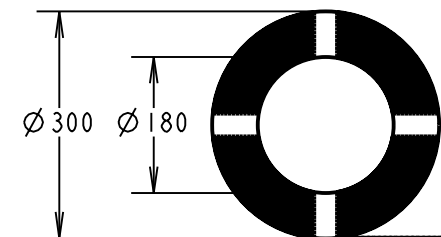
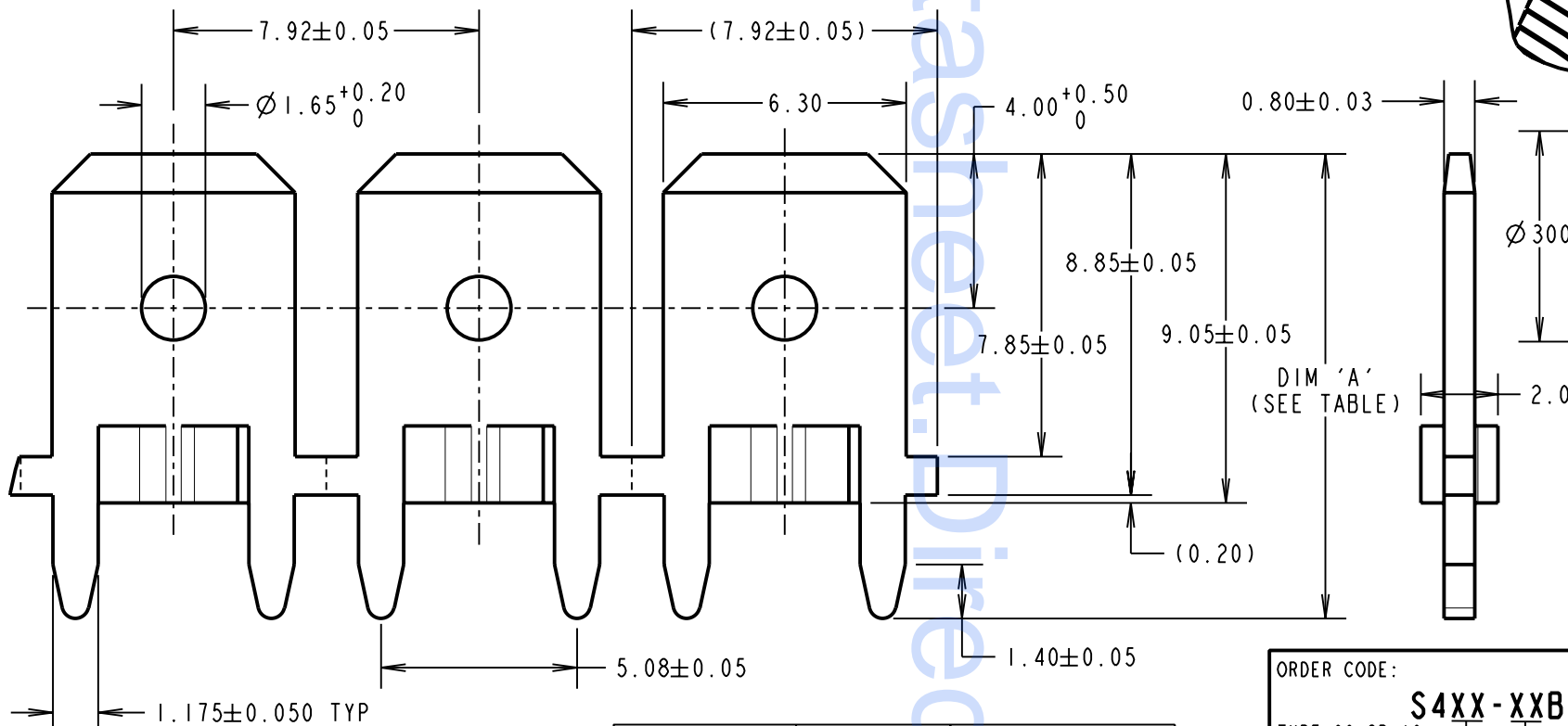
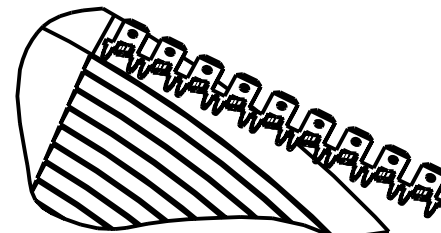

COIL DIMENSIONS

NOTE:

- ANTI-ROCKING FEATURE.
- QUANTITY OF TABS PER COIL = 4K.
TOTAL WEIGHT PER COIL = 1.71kg.
- RECOMMENDED MOUNTING HOLE SIZE = $\varnothing 1.25 \pm 0.06\text{mm}$.

PART No.	DIM 'A'	PCB THICKNESS
S409-XXBX	12.05	1.60
S410-XXBX	12.85	2.40

ORDER CODE:

S4XX-XXBX

TYPE 09 OR 10
(SEE TABLE)

FINISH:
06 = 4 μ 90/10 TIN/LEAD
46 = 4 μ 100% TIN

CP	8	28.01.10	8128
NAME	ISS.	DATE	C/NOTE
APPROVED: C. PENROSE			
CHECKED: R. ADDE			
DRAWN: D. BECK			
CUSTOMER REF.:			
ASSEMBLY DRG:			

HARWIN

HARWIN USA TEL: 603 893 5376 FAX: 603 893 5396 mis@harwin.com	HARWIN Europe (UK) TEL: 023 9231 4545 FAX: 023 9231 4590 mis@harwin.co.uk	HARWIN Asia TEL: +65 6 779 4909 FAX: +65 6 779 3868 mis@harwin.com.sg
--	--	--

THIS DRAWING AND ANY INFORMATION OR DESCRIPTIVE MATTER SET OUT HEREON ARE CONFIDENTIAL AND COPYRIGHT PROPERTY OF THE HARWIN GROUP AND MUST NOT BE DISCLOSED, LOANED, COPIED OR USED FOR MANUFACTURING, TENDERING OR FOR ANY OTHER PURPOSE WITHOUT THEIR WRITTEN PERMISSION.

TOLERANCES
X. = $\pm 1\text{mm}$
X.X = $\pm 0.25\text{mm}$
X.XX = $\pm 0.10\text{mm}$
X.XXX = $\pm 0.01\text{mm}$
ANGLES = $\pm 5^\circ$
UNLESS STATED

MATERIAL:
BRASS CW508L H150
TO BS EN 1652
(CuZn37 HARD)

FINISH: 4 μ 90/10 TIN/LEAD

S/AREA: mm²

TITLE:
6.3mm BLADE VERTICAL
COILED TAB TERMINAL

DRAWING NUMBER:
S409-XXBX, S410-XXBX

SHT
3
OF
3