

Mechanical Package Drawing

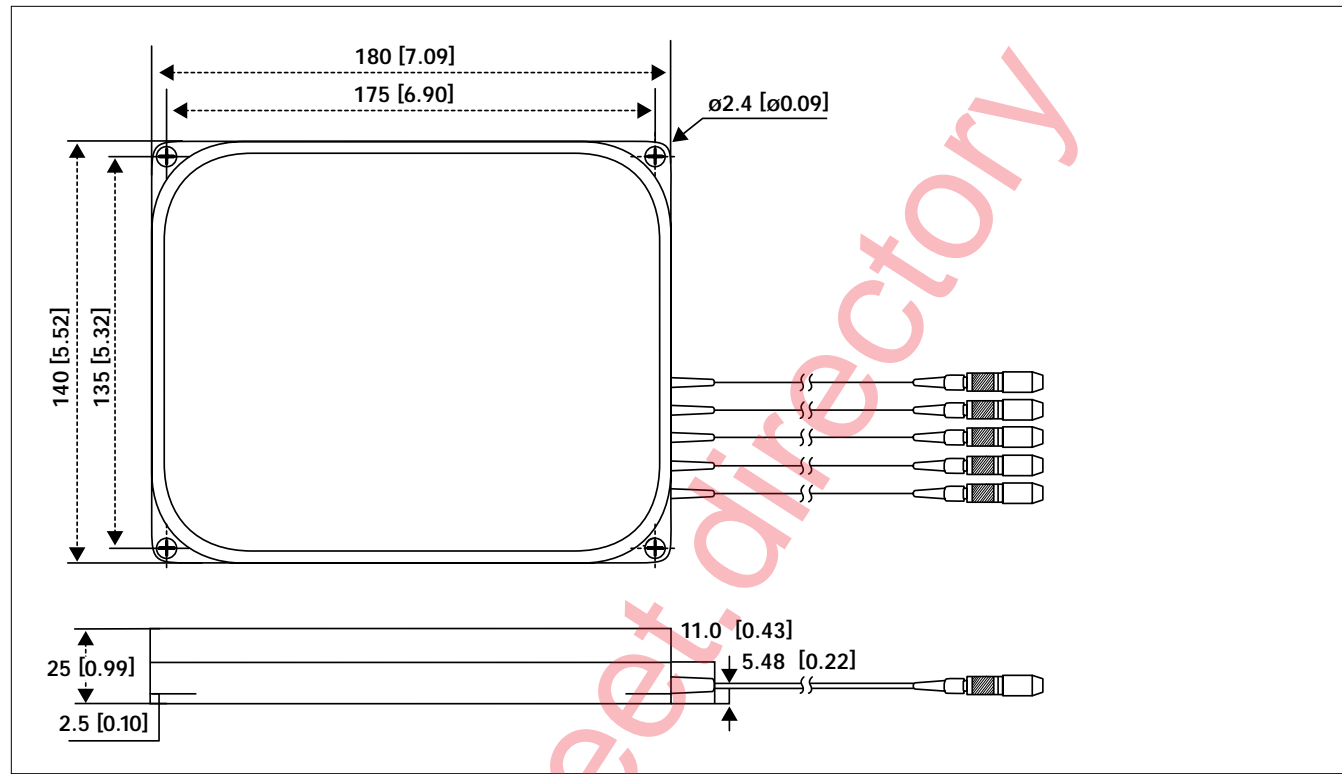

* 80 channels consist of two 40-channel units

Order Information

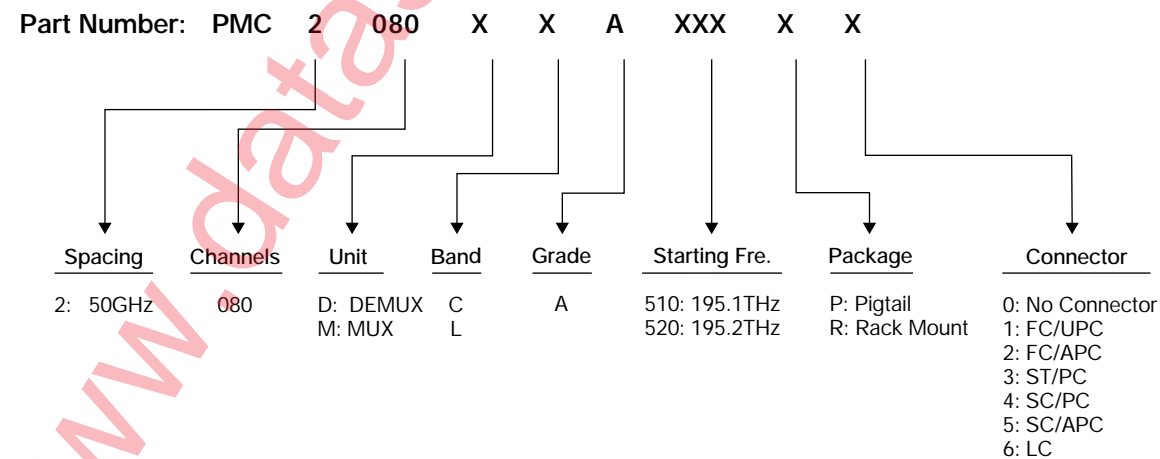

AVANEX™
www.avanex.com
Nasdaq: AVNX

Corporate Headquarters
40919 Encyclopedia Circle
Fremont, CA 94538 USA
Telephone 510-897-4188
Fax 510-897-4189

Richardson Technology Center
405 International Parkway, Suite 209
Richardson, TX 75081 USA
Telephone 972-231-7980
Fax 972-231-9913

PowerMux™ Channel Processor

80 Channel Wavelength Channel Processor
PMC Series

Avanex PMC Series use an innovative patent pending technology to provide 50 GHz channel spacing dense WDM MUX/DEMUX function with low insertion loss, low ripple passband, and high channel isolation.

Features

- 50 GHz Channel Spacing
- 80 Channel Module
- Low Insertion Loss
- High Channel Isolation
- Flexible Upgrade Path
- Epoxy-Free Optical Path
- Excellent Stability and Reliability

Applications

- 80 Channel DWDM MUX
- 80 Channel DWDM DEMUX
- 50 GHz Channel DWDM Add/Drop

Functional Diagram

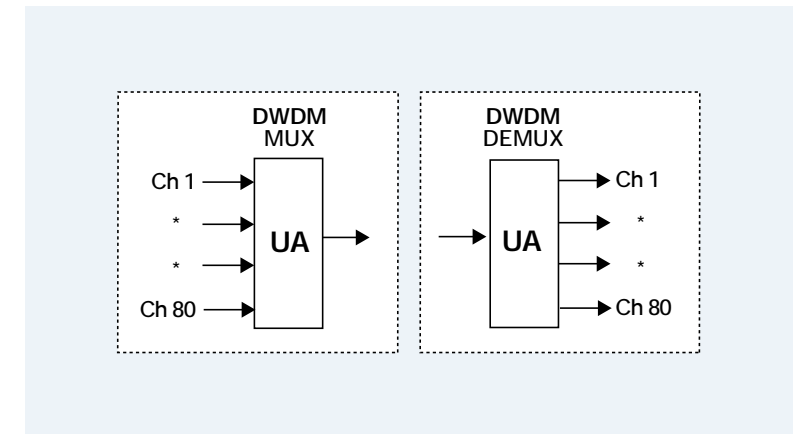

POWERED by AVANEX™
www.avanex.com



Specifications

Parameters		Specifications		
		Min	Typ	Max
Channel Number		80 Channels, 50 GHz (0.4 nm) Spacing		
Channel Center Wavelength λ_c (nm)	ITU Grid (C Band)	1528 – 1565		
	ITU Grid (L Band)	1570 – 1610		
Channel Passband (nm)	- 1.0 dB Bandwidth	$\lambda_c \pm 0.08$		
Insertion Loss (dB)	Ch1, ... Ch 80↔Common		7.0	9.0
Insertion Loss Variation (dB)	Between Channels		± 1.0	± 1.5
	Within Channel Passband		± 0.2	± 0.25
Passband Flatness(k)(dB/nm)		-3		+3
Cross-Talk (dB)	Between Channels	25	32	
	Total Cross-Talk	21	23	
Polarization Dependent Loss (dB)	Within Channel Passband			0.5
Group Delay (ps)		-10		+10
Polarization Mode Dispersion (ps)	Within Channel Passband			0.5
Dispersion (ps/nm)		-100		100
Return Loss (dB)	All Ports	45	55	
Directivity (dB)	Ch1, ... Ch 80 Ports	65	70	
Optical Power Handling (dBm)		24		
Operating Temperature (°C)		0		65
Storage Temperature (°C)		-40		85
Connector Type		LC or SC		
Package Dimension (mm)		40 Channel Package: 180 (L) x 140 (W) x 25 (H)		

Definition of Parameters

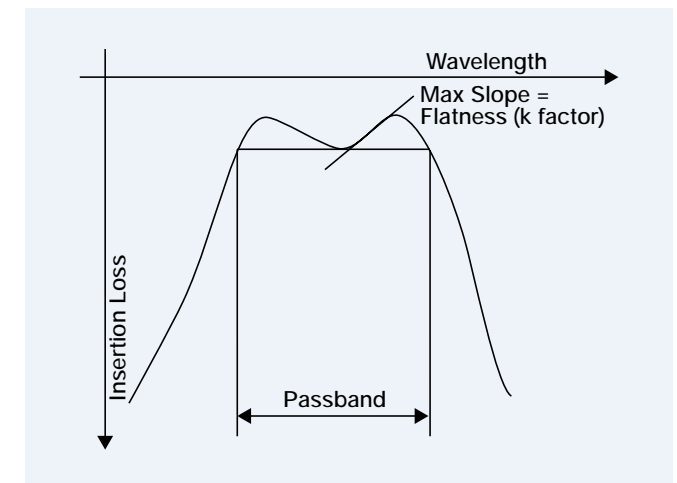
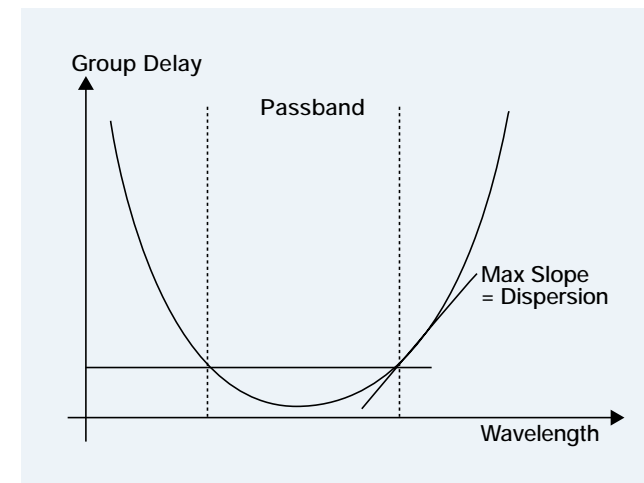
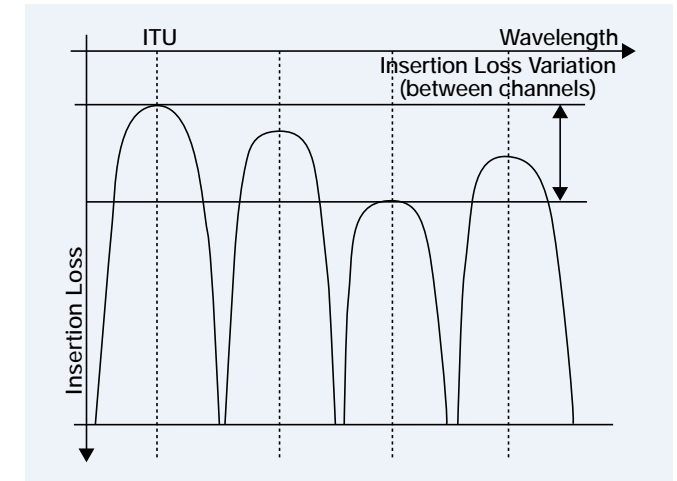
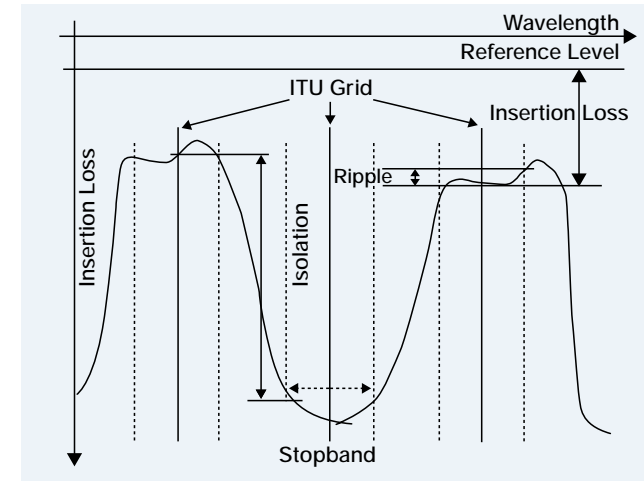

Key Performance

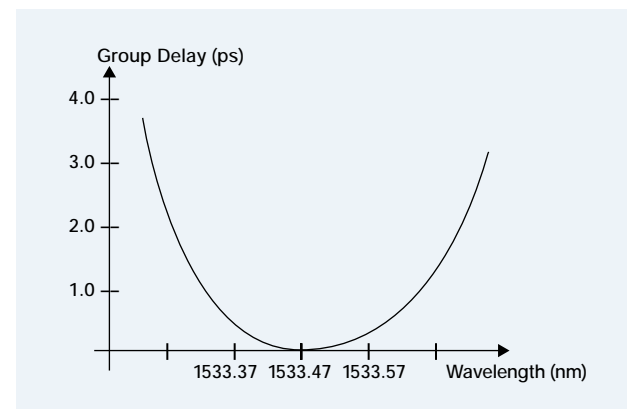
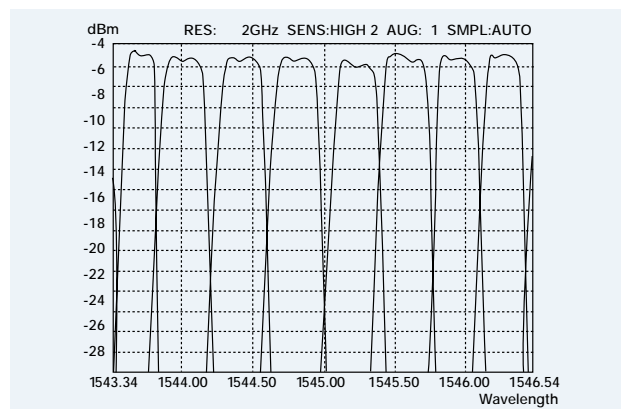

Application Configuration

