

**2 • ROW**  
**Connectors**  
**Crimp Removable**  
**Receptacle**

**RM2**

10 thru 100  
Contacts

RECEPTACLE: RM222 - 100 - 581 - 5500  
XXXXX - XXX - XXX - XXXX

**CRIMP REMOVABLE RECEPTACLE**

SERIES	
RM	.075 Screw Machine Connector
BODY	
2	ROWS 2-Row
2	BODY STYLE Receptacle, straight, with mounting ears
4	Receptacle, straight, without mounting ears
2	BODY MATERIAL PPS thermoplastic
NUMBER OF CONTACTS	
10, 20, 30, 40, 50, 60 70, 80, 90, 100	
CONTACTS	
57	Socket, straight, crimp removable (20-22 AWG)*
58	Socket, straight, crimp removable (24-26 AWG)*
59	Socket, straight, crimp removable (28-30 AWG)*
00	None
PLATING OPTIONS	
1	Military Specification (per MIL-C-55302) (50µ" Au Engagement area, 20µ" Au Termination)
HARDWARE (#2-56)	
PLEASE SEE PAGE 2-2 FOR HARDWARE	
NOTES	
* Full compliment of crimp removable sockets packaged with connector.	
1. Contact factory for crimp and removal tool information.	

**RM2**

10 thru 100  
Contacts

**Crimp  
Removable**

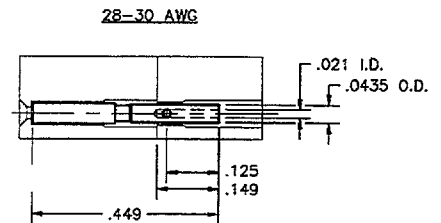
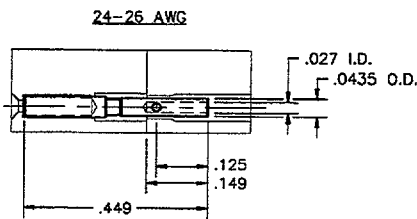
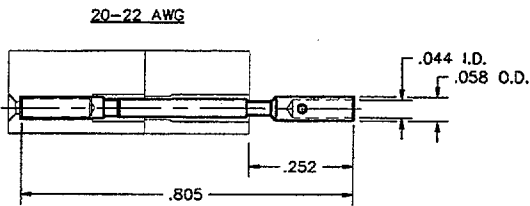
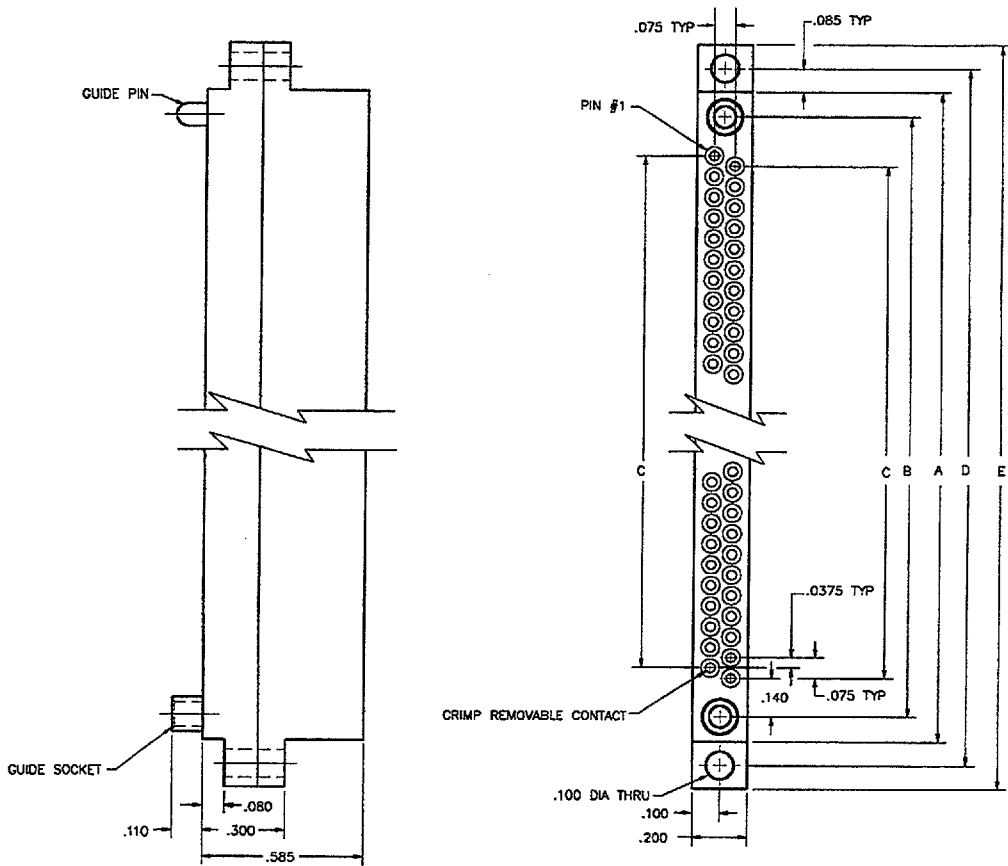

NOTE: When using crimp contacts with 20 gauge barrel, barrel must be cut off prior to removing contact from connector body.

TABLE 1

NO. OF CONTACTS	A	B	C	D	E
10	.797	.617	.300	.967	1.137
20	1.172	.992	.675	1.342	1.512
30	1.547	1.367	1.050	1.717	1.887
40	1.922	1.742	1.425	2.092	2.262
50	2.297	2.117	1.800	2.467	2.637
60	2.672	2.492	2.175	2.842	3.012
70	3.047	2.867	2.550	3.217	3.387
80	3.422	3.242	2.925	3.592	3.762
90	3.797	3.617	3.300	3.967	4.137
100	4.172	3.992	3.675	4.342	4.512