



T-25-17

2N5204-2N5207

Powerex, Inc., Hillis Street, Youngwood, Pennsylvania 15697 (412) 925-7272
 Powerex Europe, S.A., 428 Avenue G. Durand, BP107, 72003 Le Mans, France (43) 41.14.14

Phase Control SCR
22 Amperes/600-1200 Volts

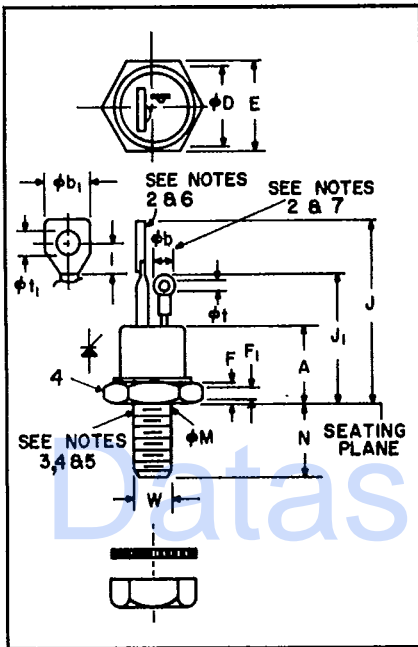

2N5204-2N5207 Outline Drawing
 Complies with TO-48

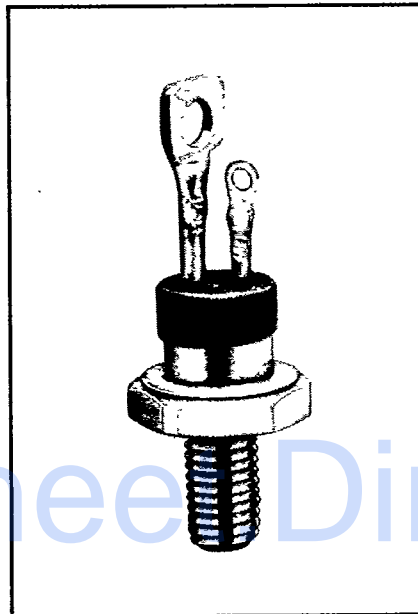

2N5204-2N5207
Phase Control SCR
22 Amperes/600-1200 Volts

Description

Powerex Silicon Controlled Rectifiers (SCR) are reverse blocking triode thyristor semiconductor devices designed for power switching and phase control applications. They are all-diffused devices backed by years of design and field experience.

Features:

- Low Gate Current
- Low On-State Voltage
- Hermetic Packaging
- Low Thermal Impedance
- Long Creepage Path
- Thermal Fatigue Resistant
- Excellent Surge Rating

Applications:

- Phase Control
- Power Supplies
- Static Switch
- Battery Chargers
- Motor Control

Ordering Information

Example: Select the complete 6 digit part number you desire from the table — i.e. 2N5206 is a 1000 Volt, 22 Ampere Phase Control SCR.

Type	Voltage V_{DRM} / V_{RRM}	Current Rating $I_{T(AV)}$ Amperes (22)
2N5204	600	—
2N5205	800	—
2N5206	1000	—
2N5207	1200	—

Dimension	Inches		Metric	
	Min.	Max.	Min.	Max.
A	.330	.505	8.38	12.83
ϕb ②	.115	.140	2.92	3.56
ϕb_1 ②	.210	.300	5.33	7.62
ϕD	—	.544	—	13.82
E	.544	.562	13.82	14.27
F ④	.113	.200	2.87	5.08
F ₁	.060	—	1.52	—
J	—	1.193	—	30.30
J ₁	—	.875	—	22.23
L	.120	—	3.05	—
ϕM ①	—	—	—	—
N	.422	.453	10.72	11.51
ϕt	.060	.075	1.52	1.91
ϕt_1	.125	.165	3.18	4.19
W ③	—	—	—	—

Notes:

1. Complete threads to extend to within 2½ threads of seating plane. Diameter of unthreaded portion .249" (6.32MM) Maximum, .220" (5.59MM) Minimum.
2. Angular orientation of these terminals is undefined.
3. ¼-28 UNF-2A. Maximum pitch diameter of plated threads shall be basic pitch diameter .2268" (5.76MM), minimum pitch diameter .2225" (5.66MM), reference: screw thread standards for Federal Service 1957, Handbook H28, 1957, P1.

4. A chamfer (or undercut) on one or both ends of hexagonal portion is optional.
5. Case is anode connection.
6. Large terminal is cathode connection.
7. Small terminal is gate connection.
8. Insulating kit available upon request.
- A. ¼-28 steel nut, Ni. plated, .178 min. thk.
- B. Ext. tooth lockwasher, steel, Ni. plated, .023 min. thk.



T-25-17

Powerex, Inc., Hillis Street, Youngwood, Pennsylvania 15697 (412) 925-7272

Powerex Europe, S.A., 428 Avenue G. Durand, BP107, 72003 Le Mans, France (43) 41.14.14

2N5204-2N5207

Phase Control SCR

22 Amperes/600-1200 Volts

Absolute Maximum Ratings, ($T_j = 125^\circ\text{C}$ unless otherwise specified)

Ratings	Symbol	2N5204	2N5205	2N5206	2N5207	Units
Repetitive peak off-state voltage	V_{DRM}	600	800	1000	1200	Volts
Repetitive peak reverse voltage	V_{RRM}	600	800	1000	1200	Volts
Non-repetitive peak reverse voltage	V_{RSM}	720	960	1200	1440	Volts
2N5204-2N5207						
RMS On-State Current	$I_{T(RMS)}$			35		Amperes
Average On-State Current (Nominal, See Charts) $T_c = 40^\circ\text{C}$	$I_{T(AV)}$			22		Amperes
Peak One-Cycle Surge (Non-Repetitive) On-State Current (60 Hz)	I_{TSM}			300		Amperes
Peak One-Cycle Surge (Non-Repetitive) On-State Current (50 Hz)	I_{TSM}			272		Amperes
I^2t (for Fusing), 8.3 ms	I^2t			375		A^2sec
I^2t (for Fusing), 1.0 ms	I^2t			200		A^2sec
Critical Rate-of-Rise of On-State Current (Repetitive)	di/dt			100		$\text{A}/\mu\text{s}$
Peak Gate Power Dissipation	P_{GM}			60		Watts
Average Gate Power Dissipation	$P_{G(AV)}$			10		Watts
Peak Reverse Gate Voltage	V_{RGM}			5		Volts
Storage Temperature	T_{stg}			-40 to 150		$^\circ\text{C}$
Operating Temperature	T_j			-40 to 125		$^\circ\text{C}$
Mounting Torque ①	—			30		in.-lb.
Mounting Torque ①	—			35		kg-cm

① Consult recommended mounting procedures; do not exceed maximums.



T-25-17

Powerex, Inc., Hillis Street, Youngwood, Pennsylvania 15697 (412) 925-7272
 Powerex Europe, S.A., 428 Avenue G. Durand, BP107, 72003 Le Mans, France (43) 41.14.14

2N5204-2N5207
 Phase Control SCR
 22 Amperes/600-1200 Volts

Electrical Characteristics

Characteristics	Symbol	Test Conditions	2N5204	2N5205	2N5206	2N5207	Units
Voltage—Blocking State Maximums							
Forward Leakage, Peak	I_{DRM}	$T_j = -40^\circ\text{C}$ to 125°C , $V_D = V_{DRM}$	3.3	2.5	2.0	1.7	mA
Reverse Leakage, Peak	I_{RRM}	$T_j = -40^\circ\text{C}$ to 125°C , $V_R = V_{RRM}$	3.3	2.5	2.0	1.7	mA
2N5204-2N5207							
Current—Conducting State Maximums							
Peak On-State Voltage	V_{TM}	$T_C = 25^\circ\text{C}$, $I_{TM} = 70\text{ A}$		2.3			Volts
Holding Current	I_H	$V_D = 24\text{V}$, $R_L = 20\Omega$, $T_j = 25^\circ\text{C}$		100			mA
		$V_D = 24\text{V}$, $R_L = 20\Omega$, $T_j = -40^\circ\text{C}$		200			mA
Switching							
Typical Turn-Off Time	t_q	—		75			μs
Typical Critical dv/dt exponential to V_{DRM}	dv/dt	$T_j = 125^\circ\text{C}$, Gate Open		100			V/ μs
Thermal							
Maximum Thermal Resistance, Junction to Case	$R_{th(j-c)}$			1.5			$^\circ\text{C}/\text{Watt}$
Gate — Maximum Parameters							
Gate Current to Trigger	I_{GT}	$V_D = 12\text{V}$, $R_L = 12\Omega$, $T_j = 25^\circ\text{C}$		40			mA
		$V_D = 12\text{V}$, $R_L = 12\Omega$, $T_j = -40^\circ\text{C}$		80			mA
Gate Voltage to Trigger	V_{GT}	$V_D = 12\text{V}$, $R_L = 12\Omega$, $T_j = 25^\circ\text{C}$		3			Volts
Minimum Non-Triggering Gate Voltage	V_{GD}	$V_D = \frac{1}{2} V_{DRM}$, $T_j = 25^\circ\text{C}$		0.3			Volts



T-25-17

Powerex, Inc., Hillis Street, Youngwood, Pennsylvania 15697 (412) 925-7272
 Powerex Europe, S.A., 428 Avenue G. Durand, BP107, 72003 Le Mans, France (43) 41.14.14

2N5204-2N5207
 Phase Control SCR
 22 Amperes/600-1200 Volts

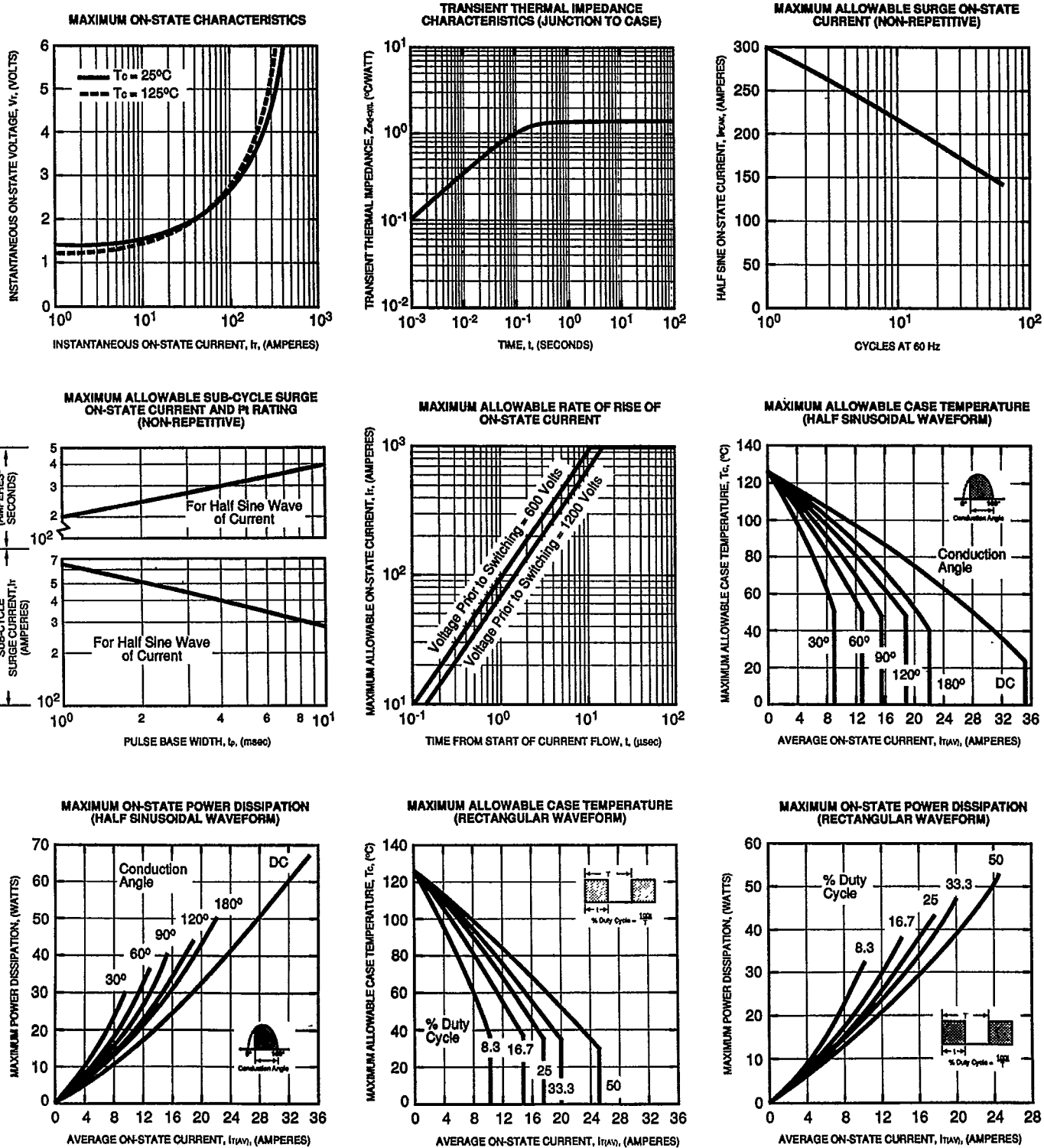



T-91-01

Powerex, Inc., Hillis Street, Youngwood, Pennsylvania 15697 (412) 925-7272
 Powerex Europe, S.A., 428 Avenue G. Durand, BP107, 72003 Le Mans, France (43) 41.14.14

Taping

STANDARD SPECIFICATIONS FOR TAPING OF MOLDED PACKAGE THYRISTORS AND TRIACS

TO-92 Package

Thyristor
CR02AM, CR03AM, CR04AM
Triac
BCR1AM

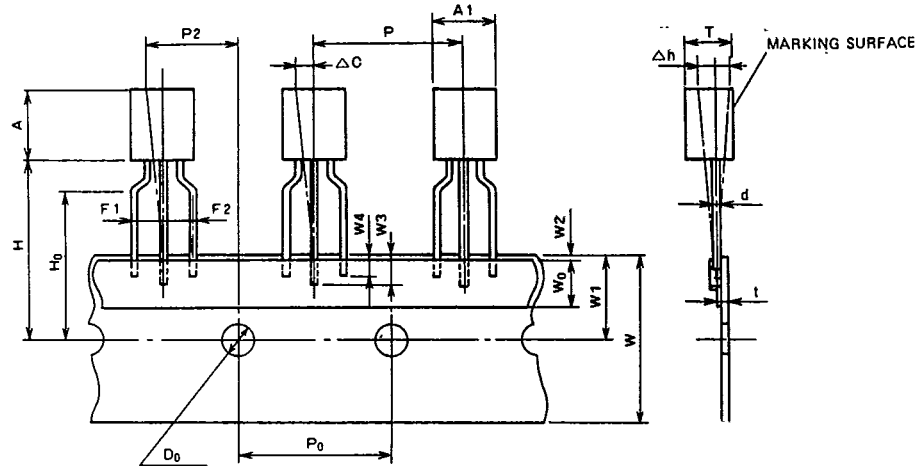

Taping dimensions

Description of symbol	Symbol	Dimensions (Unit:mm)	Remark
Product width	A1	5.0 MAX	
Product height	A	5.0 MAX	
Product thickness	T	3.7 MAX	
Lead wire diameter	d	0.6 MAX	
Sticker lead wire length (1)	W3	2.5 MIN	
Sticker lead wire length (2)	W4	2.0 MIN	
Pitch between products	P	12.7 ± 1.0	
Feed hole pitch	P ₀	12.7 ± 0.3	The cumulative pitch error is ± 1mm per 20 pitches.
Feed hole deviation (1)	P2	6.35 ± 1.3	
Distance between lead wires	F1, F2	2.5 ± 0.4	
Defective product (1)	Δh	0 ± 2.0	
Tape width	W	18.0 ± ^{1.0} / _{0.5}	
Sticker tape width	W ₀	6.0 ± 0.5	
Feed hole deviation (2)	W1	9.0 ± 0.5	
Sticker tape deviation	W2	0.5 MAX	
Position of product bottom surface	H	17.5 MIN	
Lynch height of lead wire	H ₀	16.0 ± 0.5	
Feed hole diameter	D ₀	4.0 ± 0.2	
Tape thickness	t	0.7 ± 0.2	
Defective product (2)	ΔC	0 ± 1.0	



Powerex, Inc., Hills Street, Youngwood, Pennsylvania 15697 (412) 925-7272
 Powerex Europe, S.A., 428 Avenue G. Durand, BP107, 72003 Le Mans, France (43) 41.14.14

Powerex Semiconductor Data Book
 Taping

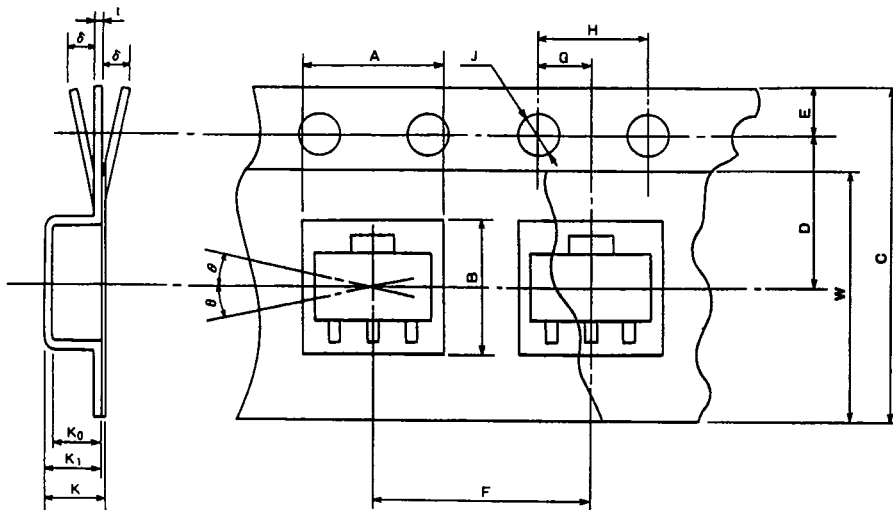

SOT-89 Package

Thyristor
 CR08AS

Taping dimensions

Description of symbol		Symbol	Dimensions/angles Unit:mm	Remark
Parts Insertion	Height	A	5.0 ± 0.1	Cross-section of the surface 0.5mm above the Inner bottom
	Width	B	4.6 ± 0.1	Cross-section of the surface 0.5mm above the inner bottom
Concave square hole	Depth	K_0	1.8 ± 0.1	Inner space
	Pitch	F	8.0 ± 0.1	Cumulative error +0.1/-0.3 MAX/10 pitches
Round feed hole	Diameter	J	$\phi 1.5 \pm 0.05$	
	Pitch	H	4.0 ± 0.1	Cumulative error +0.1/-0.3 MAX/10 pitches
	Position	E	1.5 ± 0.1	Distance between the tape edge and the hole center
Distance between center lines	Vertical	G	2.0 ± 0.5	Center line of concave square hole and round feed hole
	Horizontal	D	5.65 ± 0.05	Center line of concave square hole and round feed hole
Cover tape	Width	W	$9.5 + 0.3/-0$	Thickness: 0.1 MAX
Carrier tape	Width	C	12 ± 0.2	Warp ± 0.3 MAX
	Thickness	t	0.3 ± 0.05	
	Package hole depth	K_1	2.1 ± 0.1	
Device	Package dimensions	—	—	As shown in (e)
	Inclination	θ	30° MAX.	
Total Thickness		K	2.3 ± 0.1	Total thickness including cover and carrier tapes